



NHL-DLEM

INCANDESCENT ADJUSTABLE RECESSED DOWNLIGHT EMERGENCY UNIT

STANDARD | OPTIONAL



ILLUMINATION

- Adjustable ultra bright 8 watt bi-pin halogen lamp in a gimbal trim.
- Sealed beam PAR36-type gimbal trim with smooth chrome-plated metallized reflector and plastic lens offers optimal light distribution.

ELECTRICAL

- Dual 120/277 voltage.
- Charge rate/power "ON" LED indicator light and push-to-test switch for mandated code compliance testing.
- LVD (low voltage disconnect) prevents battery from deep discharge.
- 6V maintenance-free, rechargeable sealed lead acid battery.
- Internal solid-state transfer switch automatically connects the internal battery to lamp head for minimum 90-minute emergency illumination.
- Fully automatic solid-state, two rate charger initiates battery charging to recharge a discharged battery in 24 hours.

MOUNTING

- Compatible with drop ceiling mount installations. Bar hangers included.

HOUSING

- 6" recessed housing with mounting bar hangers.
- Impact-resistant thermoplastic adjustable gimbal trim.
- Junction box with 3/4" knockouts for AC input.
- White or black trim securely attached to housing with spring clips.

OPTIONS

- LED: 1.5 watt LED lamp.

WARRANTY / LISTING

- Five year warranty on all electronics and housing. Battery prorated for two years.
- Meets UL924, NFPA 101 Life Safety Code, NEC, OSHA, Local and State Codes.
- UL Listed for dry locations (25°C).

DIMENSIONS

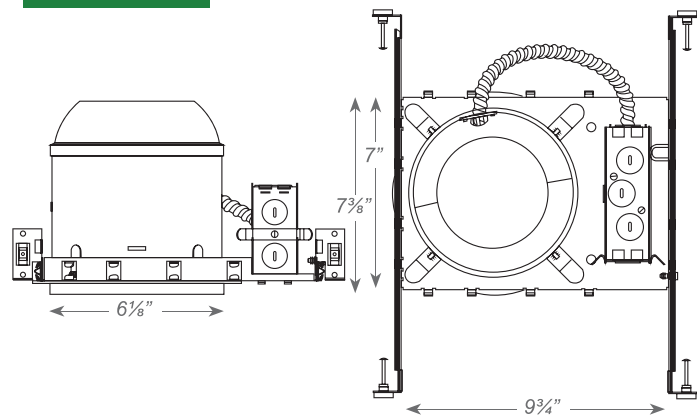

ORDERING INFORMATION

Sample Part Number: **NHL-DLEM-W**

MODEL	HOUSING COLOR		TRIM		LAMP OPTIONS	
NHL-DLEM	WHT	White	GIMBAL	Adjustable gimbal style trim	(blank)	8.0 watt halogen lamp
	BLK	Black			LED	1.5 watt LED lamp

