



CATALOG		COMMENTS
PROJECT		
PREPARED BY		
DATE		

BROADWAY 10W 20W

APPLICATIONS

New Horizon Lighting's BROADWAY Solar Billboard lights have an all-in-one design and come complete with a self-contained solar power assembly, sized to run the specified solar fixture wattage. Billboards, entrance signs, building name signs and other similar items, oftentimes, are placed in locations with little or no access to the electrical grid.

DESCRIPTION

New Horizon Lighting's solar billboard lighting systems provide lighting for large and small billboards without the need for standard utility power. Billboards, entrance signs, building name signs and othersimilar items, oftentimes, are placed in locations with little or no access to the electrical grid. Connecting them to the grid involves investments of time and money, such as cabling, trenching, and permitting. New Horizon Lighting's BROADWAY provides cost savings by eliminating the need to trench standard electric wires for installation and providing no electric bill for the life of the system.

CERTIFICATION DATA

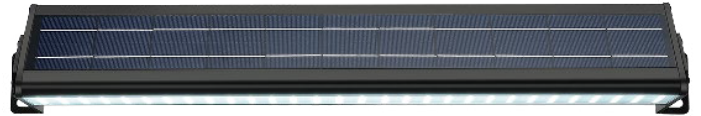

ORDERING INFORMATION

SERIES	WATTAGE	COLOR TEMPERATURE	MOUNTING OPTIONS	SIZE
NHL-TRI =BROADWAY	10=10W 1000 Lumens	40K=4000K	WM=WALL MOUNT	24=24 INCHES
	20=20W 2000 Lumens	50K=5000K	LAM=LONG ARM MOUNT	48=48 INCHES

- - - -

SPECIFICATION FEATURES



Generates More Solar Energy

- Crystalline Solar Panel with 45 degree tilted angle design. Harvest double the energy compared to horizontal panels
- Built-in tempered glass solar panel, designed to offer self-cleaning operation between rainy and sunny days



Longer Life

- LED life 50000 hours
- Easy to change modular battery pack for further lifespan extension
- OSRAM LED chips for commercial-grade performance



Dual-purpose Mounting Design

- Attached brackets design for thick boards installation and extended arms for thin boards mounting



Integrated design

- Integrated solar panel and all-in-one design
- Aircraft grade aluminum
- Integrated smart controller provides a real dusk to dawn illuminating profile all night long with first 4 hours 100% brightness, 25% brightness till dawn



CATALOG		COMMENTS
PROJECT		
PREPARED BY		
DATE		

BROADWAY 10W 20W

PRODUCT SIZE
BROADWAY 10W

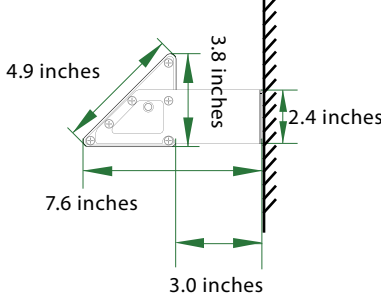
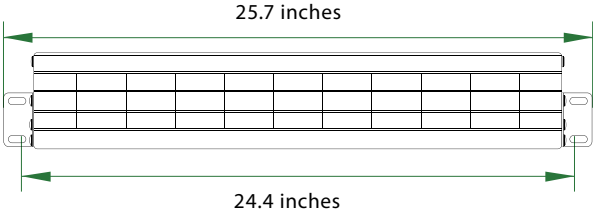

BROADWAY 20W

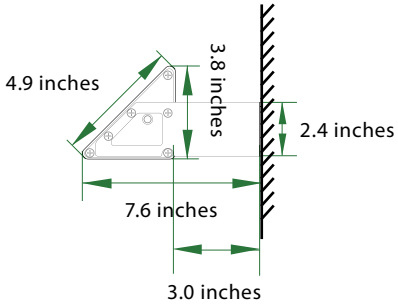
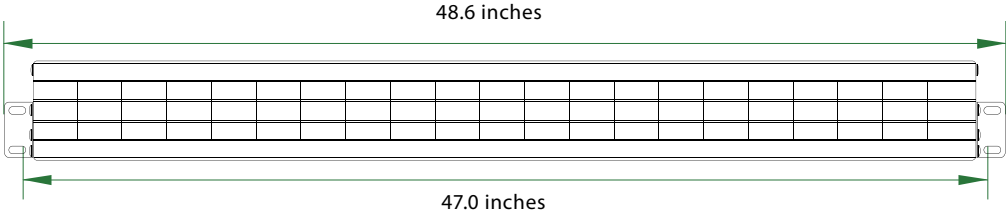



CATALOG		COMMENTS
PROJECT		
PREPARED BY		
DATE		

BROADWAY 10W 20W

SPECIFICATIONS

LED Nominal Power	10W	20W
Solar Panel	5.5V 8W Polycrystalline	5.5V 17W Polycrystalline
Lithium Ion Battery	65WH 3.7V 17.6AH	130WH 3.7V 35.2AH
CCT	4,000K, 5,000K	4,000K, 5,000K
Lumen Output@5000K	1,000	2,000
CRI	> 70	> 70
LED Chip	OSRAM	OSRAM
Beam Angle	120°	120°
Waterproof Rate	IP65	IP65
Casting	PC & Aluminum	PC & Aluminum
Efficiency@5000K	100 lm/W	100 lm/W
* Charging Time	8–10 Hours (1000W/m ²)	8–10 Hours (1000W/m ²)
Run Time (@Full Power)	2–3 Days	2–3 Days
Operation Mode	First 4 hours 100% brightness, 25% brightness till dawn	First 4 hours 100% brightness, 25% brightness till dawn
* Operating Temperature	-4 °F to 149 °F	-4 °F to 149 °F
* Charging Temperature	32 °F to 113°F	32 °F to 113°F

* The temperature can impact the battery's charging and normal operation.

* The solar charge time data is base on 77 degree F ambient temperature with the panel pointed directly at the solar radiation. The standard radiation value is 1000W/m².



CATALOG		COMMENTS
PROJECT		
PREPARED BY		
DATE		

BROADWAY 10W 20W

IES / BEAM

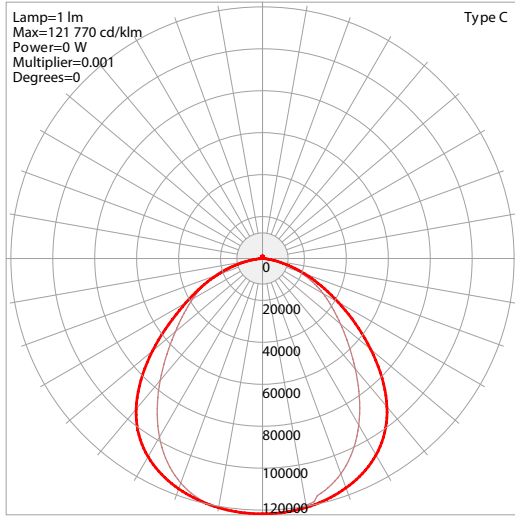

BROADWAY 10W



CATALOG		COMMENTS
PROJECT		
PREPARED BY		
DATE		

BROADWAY 10W 20W

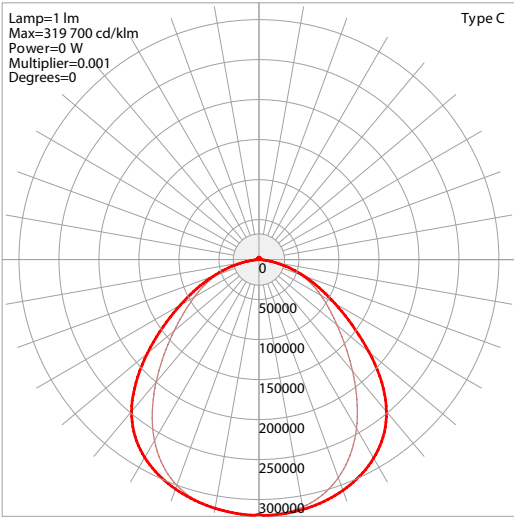

BROADWAY 20W

CATALOG		COMMENTS
PROJECT		
PREPARED BY		
DATE		

BROADWAY 10W 20W

INSTALLATION
WALL MOUNT

01

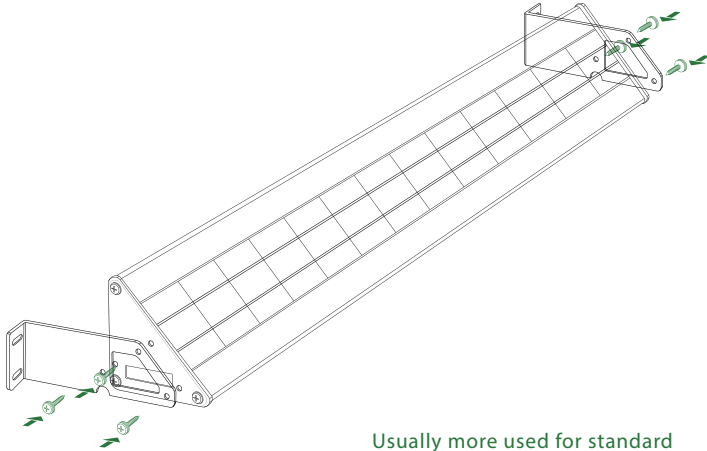

Usually more used for standard Billboards alongside express ways, the Triangle Mount is versatile and can be installed in more traditional signage, this can also be used for commercial establishments and buildings.

01

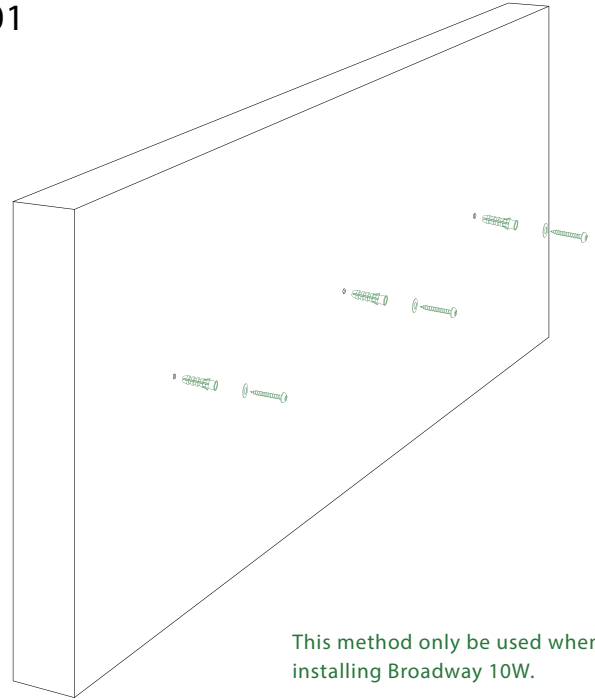

This method only be used when installing Broadway 10W.

02

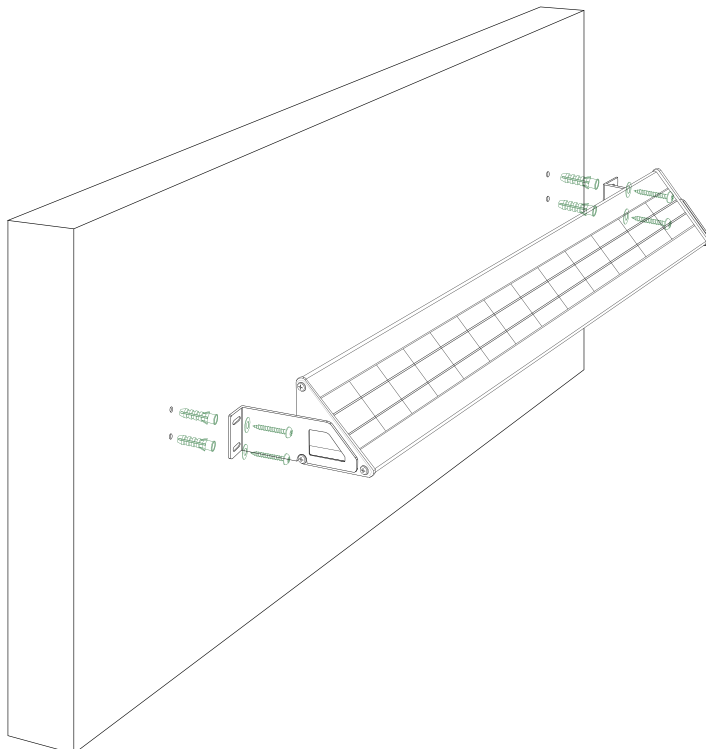

02

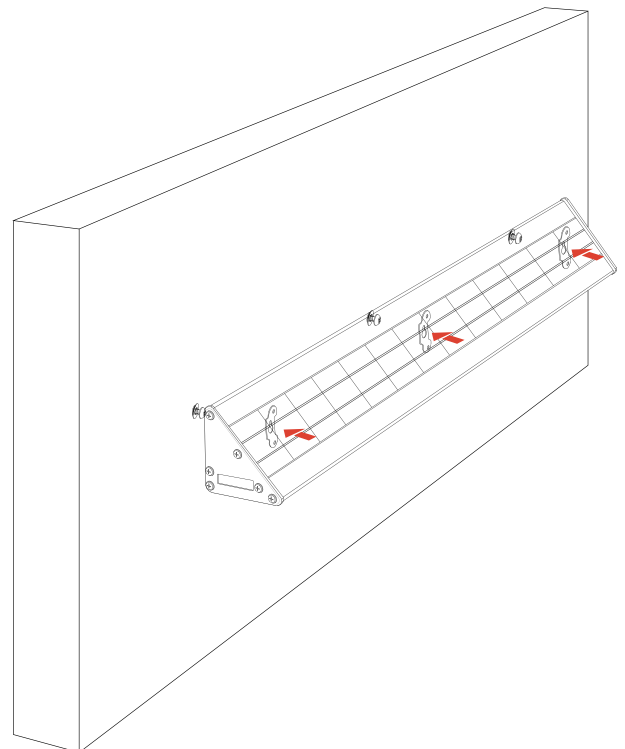



CATALOG		COMMENTS
PROJECT		
PREPARED BY		
DATE		

BROADWAY 10W 20W

LONG ARM MOUNT

01

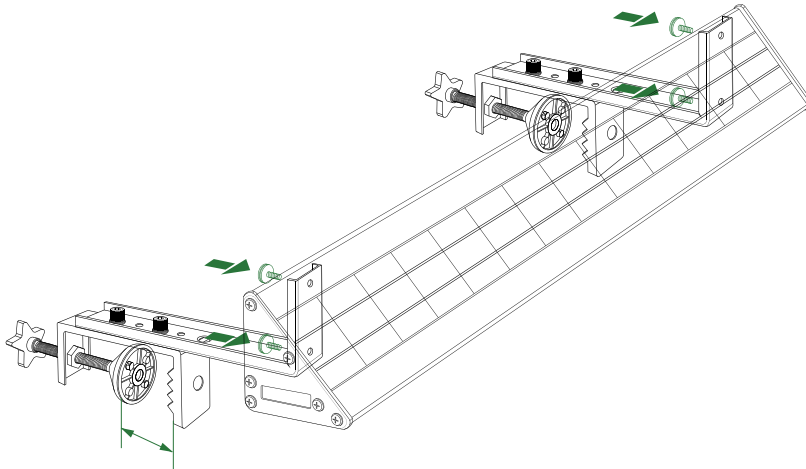

Maximum 2.5 inches

02

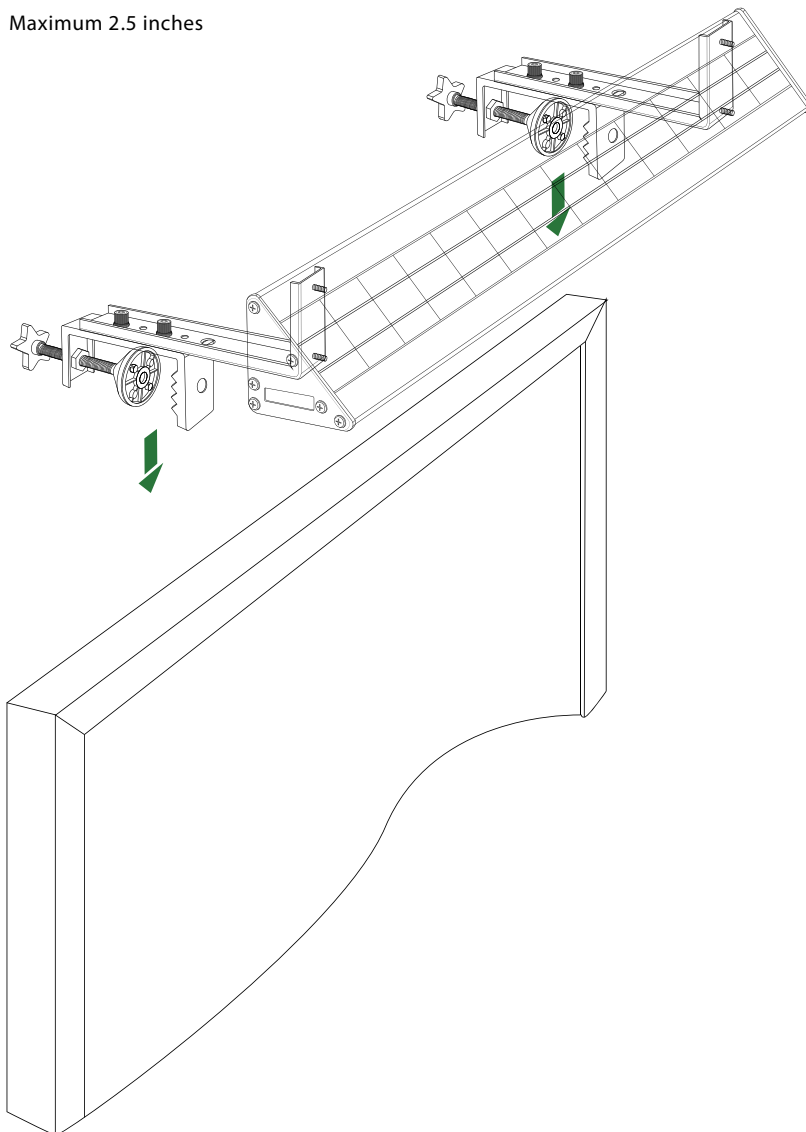

Broadway 10W needs two Long Arm Mounts. If you install Broadway 20W, you need three Long Arm Mounts.

Long Arm Mount accessories not included in standard packaging. Please advise your New Horizon Lighting sales representative if needed.

For thinner billboards, the Long Arm mount uses a tighten-to-grip system that securely places the Broadway into place. Perfect for temporary signs that need illumination for a shorter period of time.



CATALOG		COMMENTS
PROJECT		
PREPARED BY		
DATE		

BROADWAY 10W 20W

WARRANTY

BROADWAY products are covered by a 3 year limited warranty. New Horizon Lighting urban light warrants to the original purchaser that this product is free from defects in materials and workmanship for the period of 3 years from date of purchase. To obtain warranty service please contact your local distributor or sales rep for further instruction.



9 Gladney Avenue.
Bayville, NJ 08721 USA

732-833-8086

www.newhorizonlighting.com

New Horizon Lighting reserves the right to update all product data sheets at any time.

Copyright©2021–2022 *New Horizon Lighting*,
All Rights Reserved.