

INSTRUCTIONS

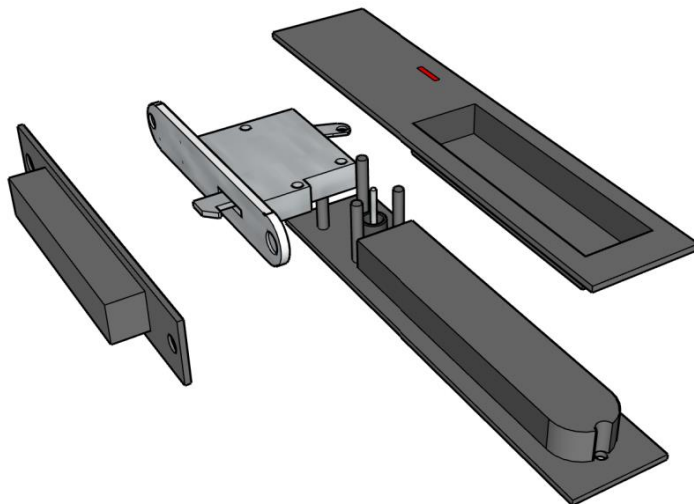

1 Use the template to mark the cutouts in the side of the door.

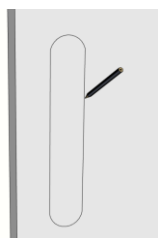

2 Drill out the cutout and chisel to the correct size

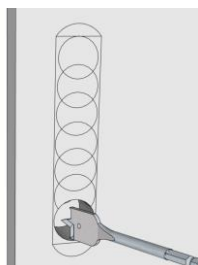

3 Drill and chisel out the lock-body cutout in the end of the door

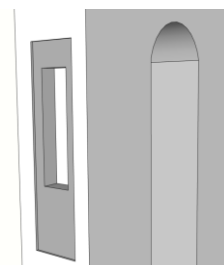

4 Insert the lock body into the cavity and fix (along with the door plate) with the wood screws.

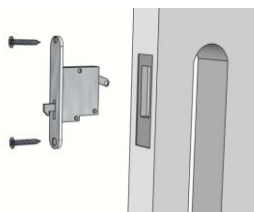

5 Insert the side of the flush pull with the indicator, into the cutout. Ensure the pin goes through the loop at the back of the lock body

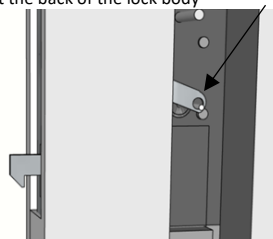

6 Insert the other side of the cavity slider and affix the 2 sides using the 2 screws provided.

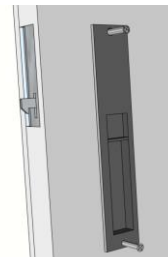

7 Determine the correct height for the catch, extend the lock hook, hold the catch against the door jamb, align them and mark on the door jamb

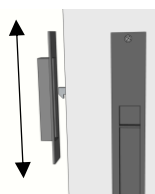

8 Mark and cut the door jamb rebate using the attached template

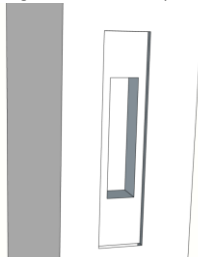

9 Insert and affix the catch. You can adjust the catch using the screw in the catch. Move it in and out to ensure a close fit between the door and jamb. Then fix the striker plate.

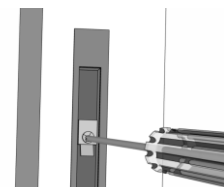

Printed from website. Ensure you print this to 100% scale and double check dimensions

mücheln®

Sliding door Locks *Privacy*

TEMPLATE

