

Mapesil LM



Neutral mould-resistant silicone sealant with very low emission level of volatile organic compounds (VOC) for stone and marble

WHERE TO USE

Mapesil LM is a solvent-free sealant with a low modulus of elasticity specifically formulated for sealing all materials sensitive to acids and plasticising agents, marble, granite, sandstone and quartz due to its chemical nature which deters surface bleeding or the migration of plasticising agents which would otherwise stain the substrate.

The chemical characteristics of the product also make it perfectly suitable for particularly delicate materials such as bricks, cellular concrete and varnished or enamelled wood.

Mapesil LM generally forms an excellent bond on non-absorbent substrates too, such as glass, ceramic, clinker, enamelled surfaces, water and solvent-based varnish, metals in general and on various types of plastic. It is also suitable for contact with absorbent mineral substrates such as concrete, render and fibre-cement.

This product generally forms a good bond on the above substrates even if a primer is not applied beforehand (contact the MAPEI Technical Services Department before).

Performs well in treated water typically found in swimming pools.

Thanks to the low modulus of elasticity of **Mapesil LM**, it is suitable for sealing internal and external fillet and expansion joints, including those subject to high levels of movement when in service, between:

- pre-fabricated panels;

- window/door fittings and wall surrounds;
- pipe-work and vertical walls;
- similar and/or different types of coating materials.

It is also suitable for sealing joints in floors with limited pedestrian traffic.

TECHNICAL CHARACTERISTICS

Mapesil LM is a one-component, solvent-free, neutral-cure silicone sealant which does not emit unpleasant odours, available in the form of a thixotropic paste. It is easy to apply on vertical and horizontal surfaces and cures at room temperature through the humidity present in the air to form a flexible sealant.

Seals made using **Mapesil LM** are extremely stable over time, even when exposed to inclement weather, industrial environments, temperature variations or water. The product remains flexible over a temperature range of between -40°C and +150°C.

Mapesil LM delays the formation of surface mould.

Mapesil LM generally offers good resistance to chemical agents. However, because of the wide range of products and service conditions, if in doubt carry out preliminary tests beforehand.

Mapesil LM bonds perfectly to most types of substrate used in the building industry without applying a primer beforehand (glass, ceramic, marble, aluminium,

Mapesil LM

zinc-plated sheet metal, concrete, stainless steel and PVC).

Primer FD must be applied beforehand in the case of prolonged immersion in water.

If in doubt, please contact the MAPEI Technical Services Department or carry out preliminary tests beforehand.

Mapesil LM is particularly suitable for surfaces sensitive to acids on which conventional neutral or acid sealants normally provoke changes in colour or staining of the substrate.

Mapesil LM complies with EN 15651-1 norm ("Sealants for internal and external façade elements") with performance rating F-EXT-INT-CC, with EN 15651-2 norm ("Sealants for glazing") type G-CC, with EN 15651-3 norm ("Sealants for joints in sanitary areas") type XS1 and EN 15651-4 norm ("Sealants for pedestrian walkways") with performance rating PW-EXT-INT-CC.

RECOMMENDATIONS

- Do not apply **Mapesil LM** on rubber, heavily-plasticised plastics or bitumen. The oil and plasticising agents in the substrate may migrate to the surface and compromise the bond or penetrate into the sealant leading to a variation in colour and mechanical characteristics.

- When **Mapesil LM** is constantly immersed in treated water typically found in swimming pools its physical-mechanics may be affected prematurely. Given the wide range of products used to treat water and the actual quantities employed, its suitability over long periods may only be guaranteed following specific laboratory testing.

- Do not use **Mapesil LM** for sealing floors subject to intense traffic (use **Mapeflex PU45**, **Mapeflex PU20** or **Mapeflex PU21**).

- Under certain conditions **Mapesil LM** may have a water-repellent effect along the edges of joints. This effect is only noticeable when surfaces are wet and is invisible when the same surfaces are dry. This phenomenon, however, has no effect on the product's performance characteristics.

- Do not use **Primer FD** when sealing stone or marble.

APPLICATION PROCEDURE

Surfaces to be sealed must be solid with no dust or loose parts and free of all traces of oil, grease, wax, old paintwork and rust.

In order to perform correctly, the sealant must be able to expand and contract freely once it has been applied in the joint.

It is important, therefore, that:

- it only bonds perfectly to the side walls of the joint and not to the bottom;
- the width of the joint is calculated correctly so that the product does not expand more than 25% of the initial width of the joint when in service;

- the thickness of seals using **Mapesil LM** is as indicated in the table below provided.

Also, to protect the substrate from staining, apply masking tape along the edges of the joint before extruding **Mapesil LM**.

Regulate the depth of the joint to avoid **Mapesil LM** sticking to the bottom by inserting **Mapefoam** polystyrene foam cord in the joint.

Application of Primer FD

If a coat of **Primer FD** is required, apply the product with a small brush where required, leave it to dry for a few minutes so that the solvent evaporates and then apply **Mapesil LM**.

Application of Mapesil LM

Mapesil LM is available in 310 ml cartridges. Cut the tip of the cartridge near the thread and screw on the nozzle. Trim the tip of the nozzle at 45° according to the width of joint required and insert the cartridge into a suitable extrusion gun.

Finish the surface of **Mapesil LM** with a suitable damp tool or a tool dipped preferably in soapy water before the skin forms on the surface.



Sealing a butt joint on natural stone



Sealing a fillet joint on natural stone

JOINT SIZE AND CONSUMPTION

EXPANSION JOINT

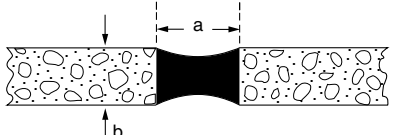

Size of joint in mm (axb)	Metres of product per cartridge
5x5	12
5x10	6
10x10	3
15x10	2
20x10	1.5
25x10	1.25
30x15	0.7
40x20	0.4

BUTT JOINT

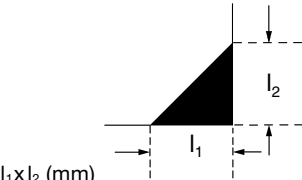

Size of joint in mm (l ₁ x l ₂)	Linear metres per cartridge
5	25
10	6
15	3
20	1.5

TECHNICAL DATA (typical values)

Conforms to the following standards:

- DIN 18545-2 class E
- DIN 18540
- ISO 11600-F class 25 LM
- ISO 11600-G class 25 LM
- ASTM C 920 class 25
- TT-S-00230 C class A
- TT-S-001543 A class A
- ASTM C 1248
- BS 5889 type A

PRODUCT IDENTITY

Classification according to EN 15651-1:	F-EXT-INT-CC
Classification according to EN 15651-2:	G-CC
Classification according to EN 15651-3:	XS1
Classification according to EN 15651-4:	PW-EXT-INT-CC
Consistency:	thixotropic paste
Colour:	100 white, 110 grey, 111 grey, 112 grey, 113 grey, 114 anthracite, 120 black, 130 jasmine, 132 beige and transparent
Density according to ISO 1183 Met. B (g/cm ³):	1.02
Dry solids content (%):	100
EMICODE:	EC1 Plus - very low emission

APPLICATION DATA (at +23°C - 50% R.H.)

Application temperature range:	from +5°C to +40°C
Extraction rate from a 3.5 mm nozzle at a pressure of 0.5 MPa (ml/min.):	50-70
Time to form surface skin:	15 minutes
Reticulation rate from outside to the inside (mm): - 1 day: - 7 days:	4 10

FINAL PERFORMANCE

Tensile strength according to ISO 8339 (N/mm ²):	0.5
Elongation at failure according to ISO 8339 (%):	250
Tear resistance (ISO 34) (N/mm ²):	4
Shore A hardness (DIN 53505):	21
Modulus of elongation according to ISO 8339 - Method A at 100% elongation (N/mm ²):	0.35
Maximum permitted movement in service (%):	25
Resistance to water:	excellent
Resistance to ageing:	excellent
Resistance to atmospheric agents:	excellent
Resistance to chemical agents, acids and diluted alkalis:	good
Resistance to soap and detergents:	excellent
Resistance to solvents:	limited
Resistance to temperatures:	from -40°C to +150°C

Mapesil LM

Coloured table

100 WHITE

110 MANHATTAN 2000

111 SILVER GREY

112 MEDIUM GREY

113 CEMENT GREY

114 ANTHRACITE

120 BLACK

130 JASMINE

132 BEIGE 2000

999 TRANSPARENT



For further information, please refer to the Safety Data Sheet available upon request.

Curing

When **Mapesil LM** is exposed to the air, the surrounding humidity sets off the cure reaction and the sealant becomes flexible.

The surrounding temperature only has a small impact on the cure rate of **Mapesil LM**, while the level of humidity in the surrounding air has the most influence. We highly recommend that the product is never applied if the temperature is below 0°C.

Cleaning

Traces of partially cured **Mapesil LM** may be removed from tools and the surface of the substrate with common solvents such as ethyl acetate, benzene or toluene. Once the product has completely cured, the silicone rubber may only be removed mechanically.

PACKAGING

Mapesil LM is available in 310 ml cartridges in 100 white, 110 grey, 111 grey, 112 grey, 113 grey, 114 anthracite, 120 black, 130 jasmine, 132 beige and transparent in display boxes containing 12 cartridges.

STORAGE

Mapesil LM cartridges may be stored for up to 18 months in a dry, cool area.

SAFETY INSTRUCTIONS FOR PREPARATION AND APPLICATION

Mapesil LM is not considered as dangerous according to the current regulation regarding the classification of mixtures. It is however recommended to use gloves, eyes protection and to take the usual precaution for the handling of chemical products. For further and complete information about the safe use of our product please refer to

the latest version of our Material Safety Data Sheet.

PRODUCT FOR PROFESSIONAL USE.

WARNING

Although the technical details and recommendations contained in this product data sheet correspond to the best of our knowledge and experience, all the above information must, in every case, be taken as merely indicative and subject to confirmation after long-term practical application; for this reason, anyone who intends to use the product must ensure beforehand that it is suitable for the envisaged application. In every case, the user alone is fully responsible for any consequences deriving from the use of the product.

Please refer to the current version of the **Technical Data Sheet**, available from our website www.mapei.com



This symbol is used to identify Mapei products which give off a low level of volatile organic compounds (VOC) as certified by GEV (Gemeinschaft Emissionskontrollierte Verlegewerkstoffe, Klebstoffe und Bauprodukte e.V.), an international organisation for controlling the level of emissions from products used for floors.



Our Commitment To The Environment
MAPEI products assist Project Designers and Contractors create innovative LEED (The Leadership in Energy and Environmental Design) certified projects, in compliance with the U.S. Green Building Council.

All relevant references for the product are available upon request and from www.mapei.com



Sealing a façade joint with Mapesil LM



BUILDING THE FUTURE