

Pannelli in legno
Wood panels
Panneaux en bois
Holzpaneele
Paneles de madera
Деревянных Панелей



installazione

CONSERVARE CON CURA

installation

KEEP CAREFULLY

installation

CONSERVER AVEC SOIN

installation

SORGFÄLTIG AUFBEWAHREN

instalación

CONSÉRVESE CON CUIDADO

установка

ТЩАТЕЛЬНО ХРАНИТЬ

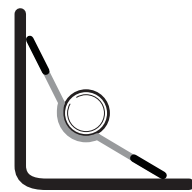
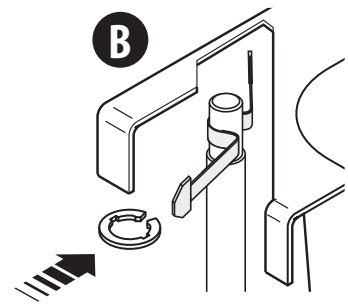
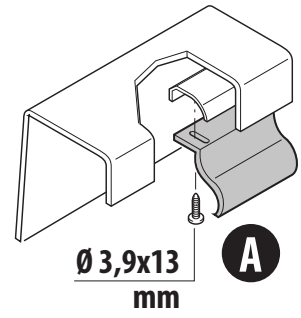
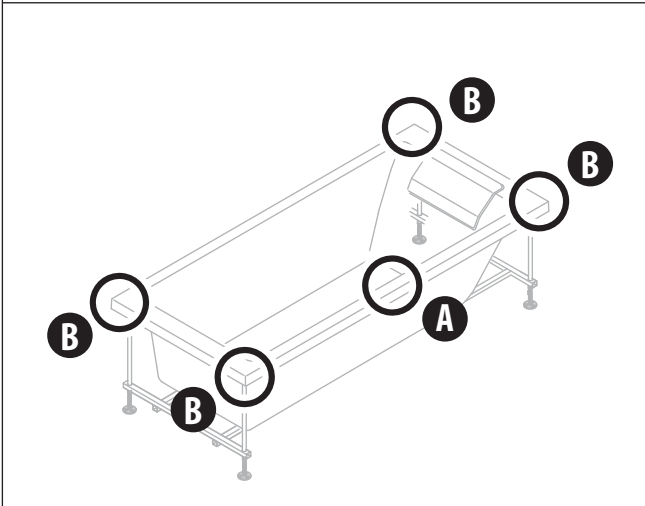
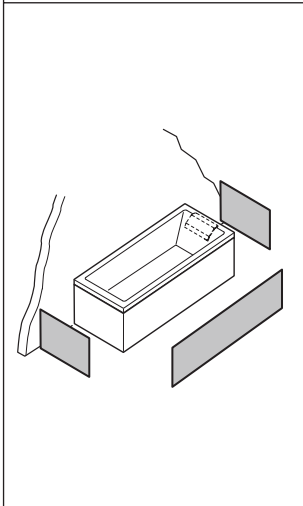
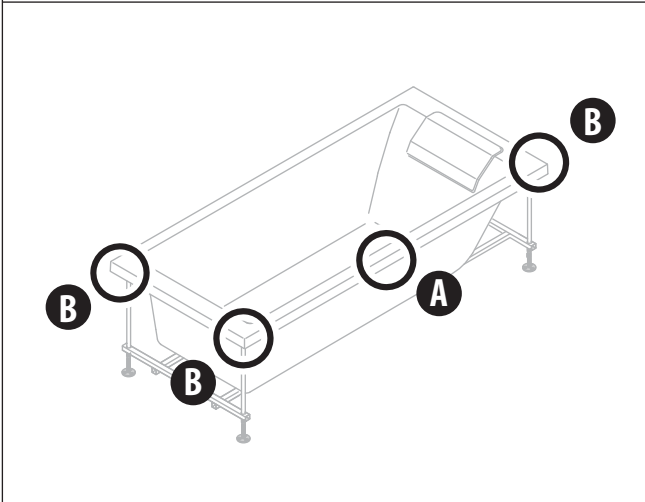
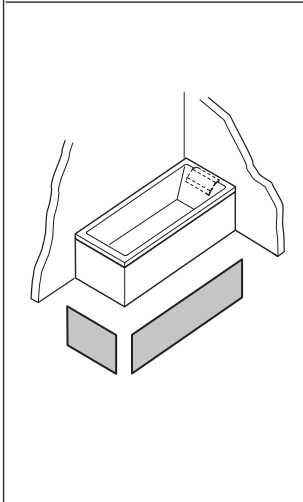
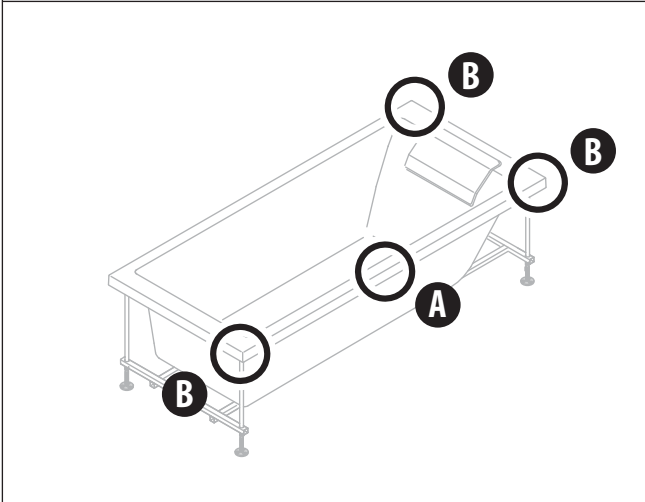
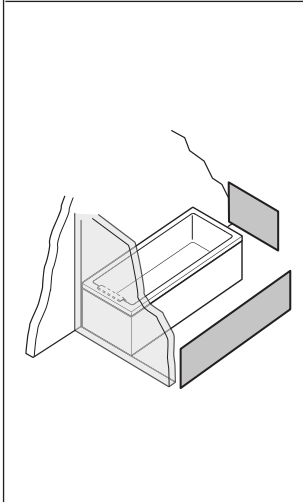
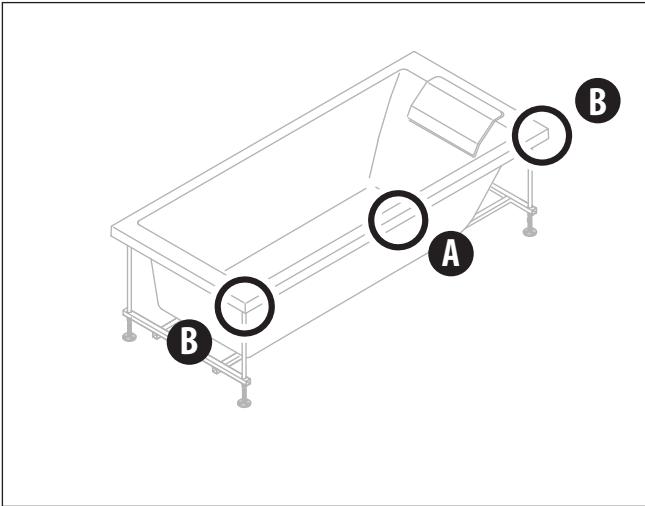
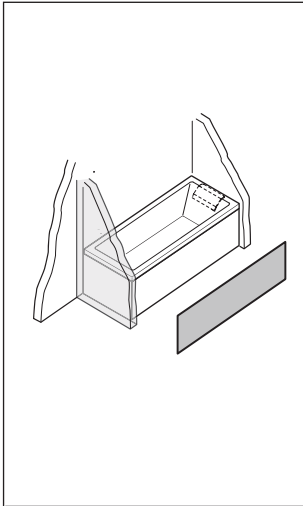

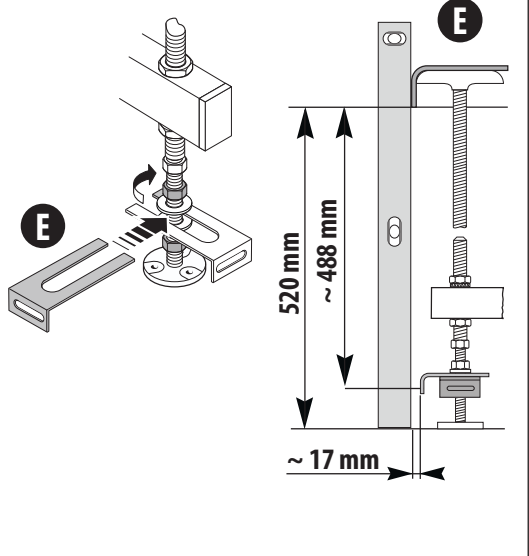
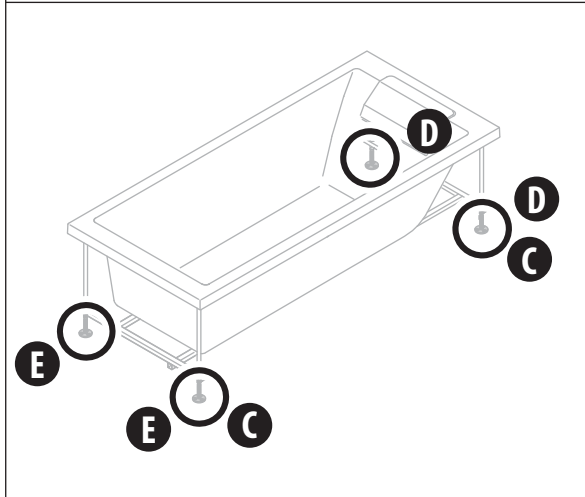
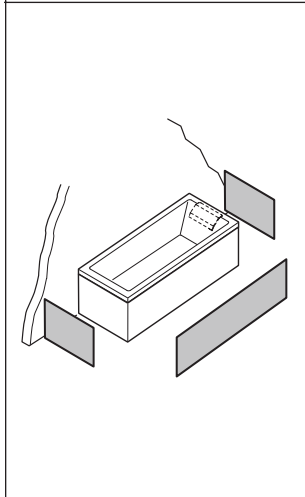
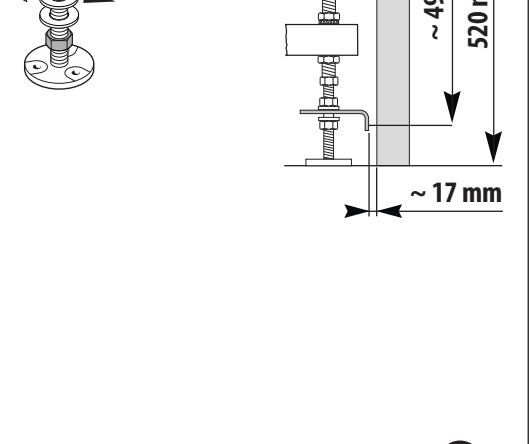
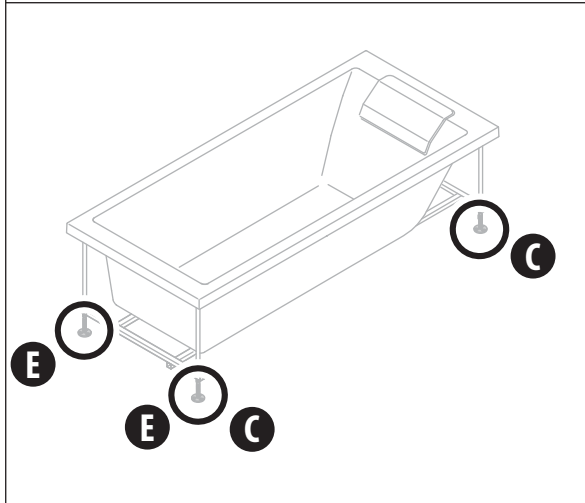
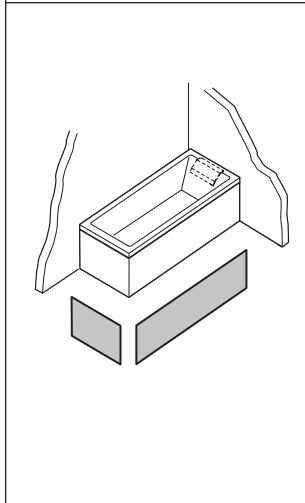
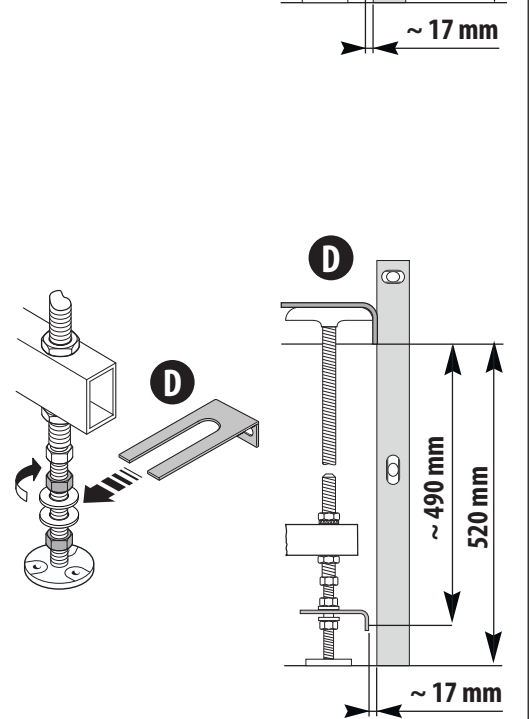
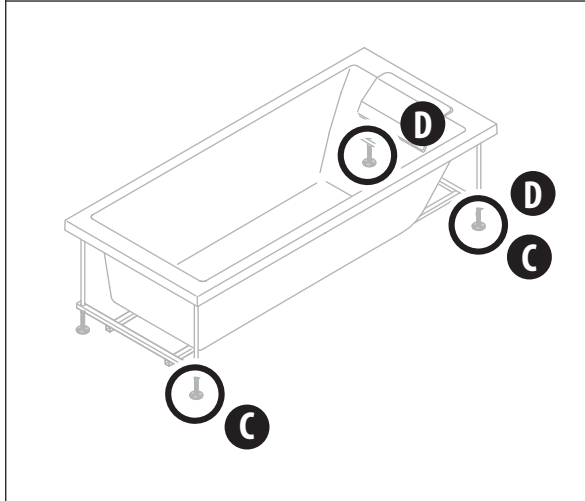
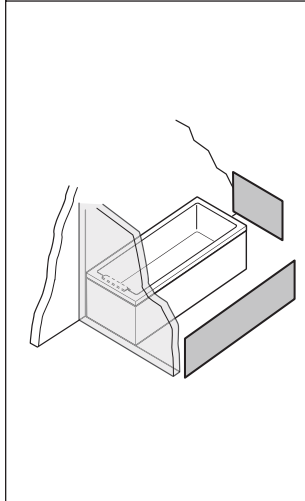
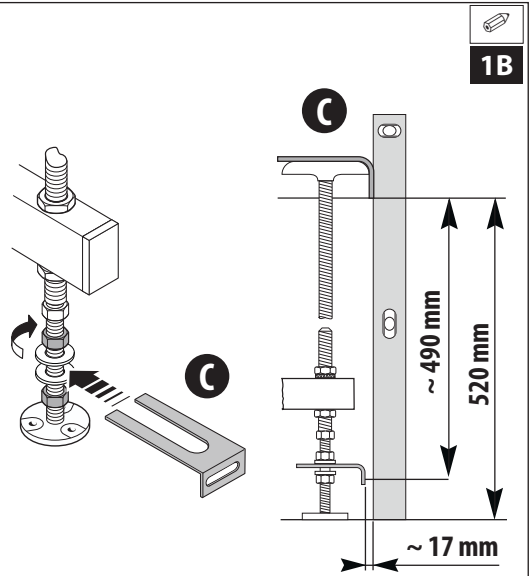
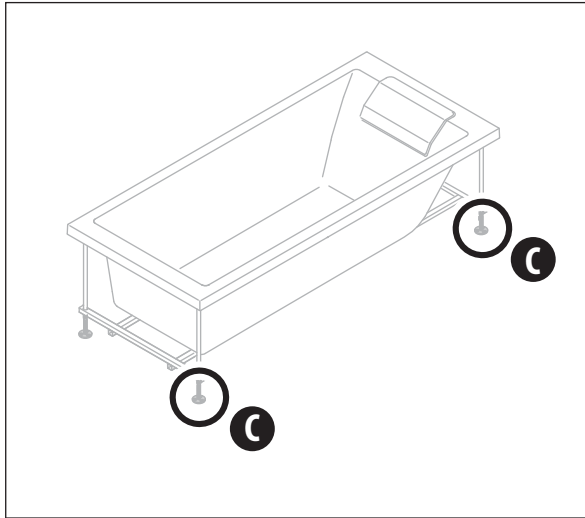
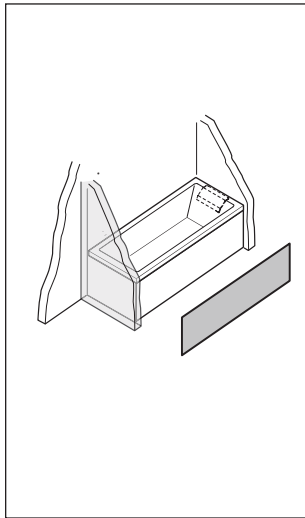

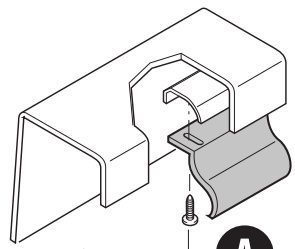
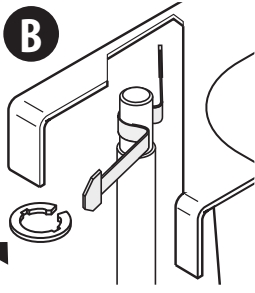
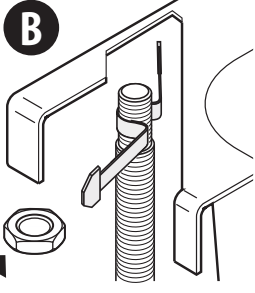
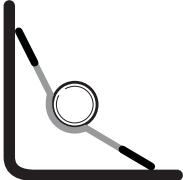
		<div style="text-align: right;">  2A </div>  <p>$\varnothing 3,9 \times 13$ mm A</p>
		<p>Type 1</p> 
		<p>Type 2</p> 
		

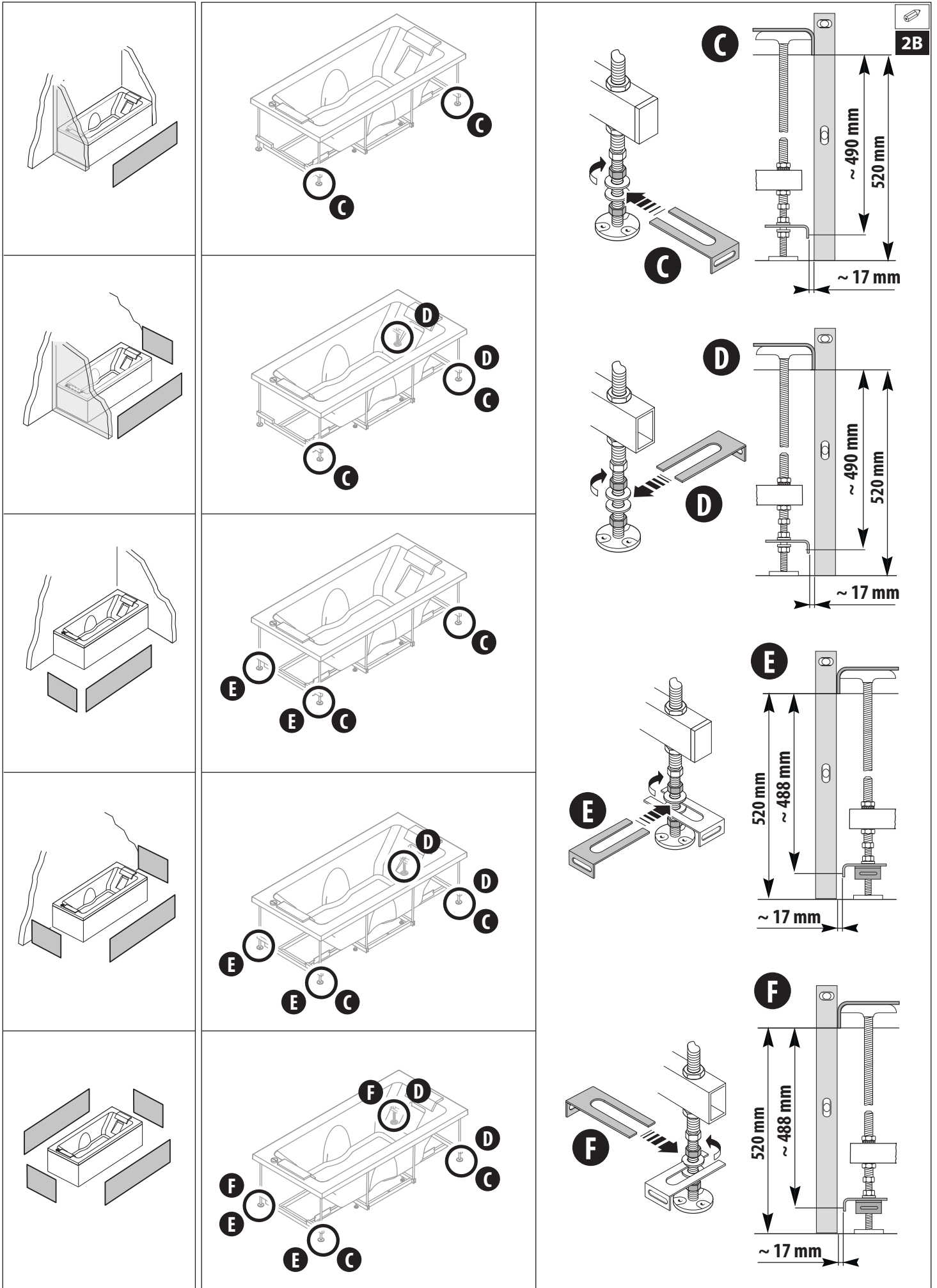

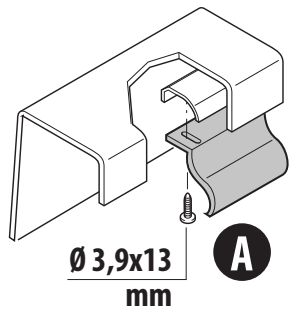
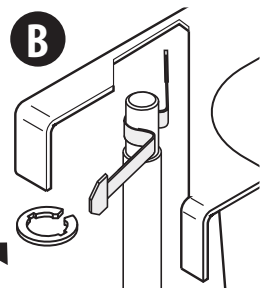
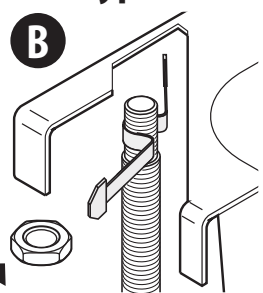
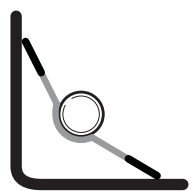
		<div style="text-align: right;">  3A </div>  <p>$\varnothing 3,9 \times 13$ mm A</p>
		<p>Type 1</p> 
		<p>Type 2</p> 
		

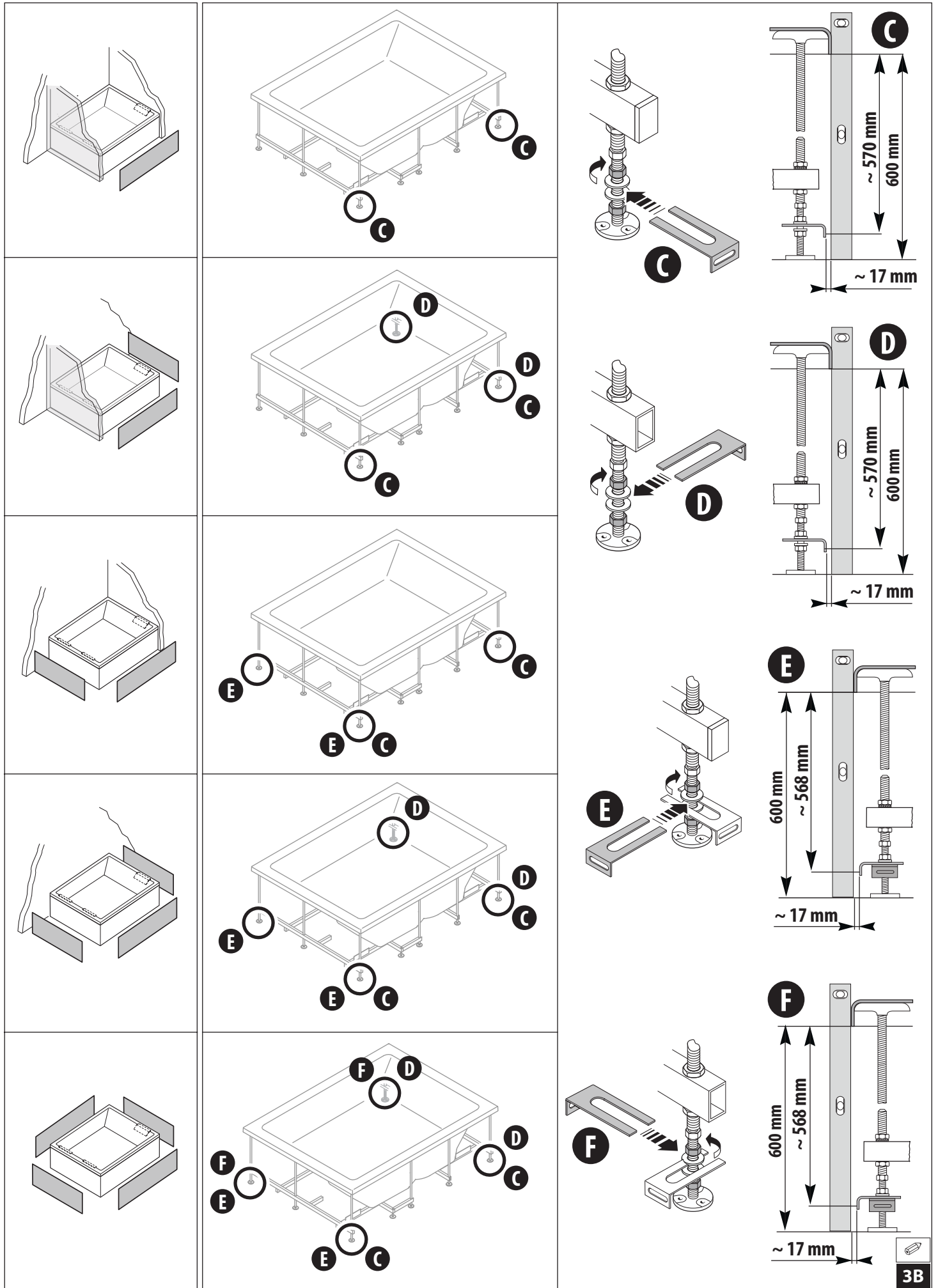

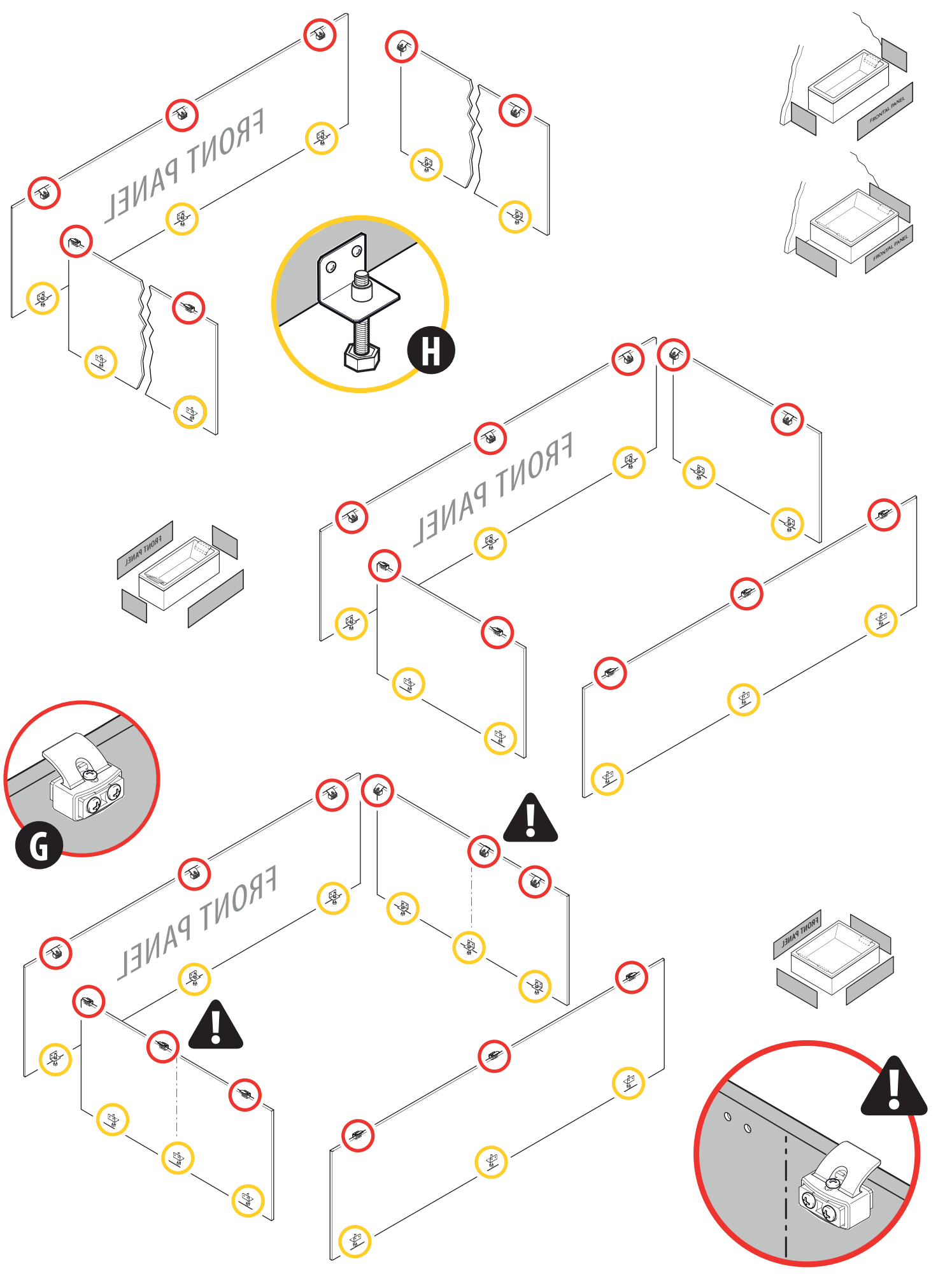

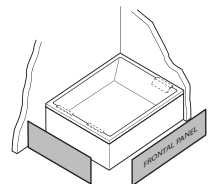
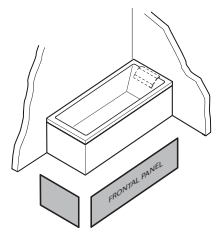
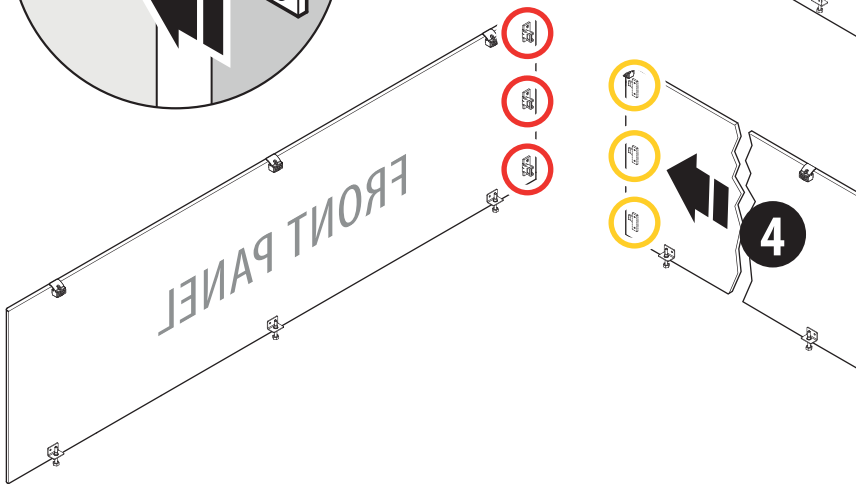
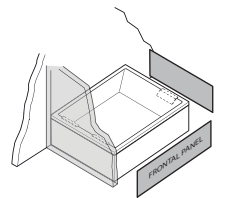
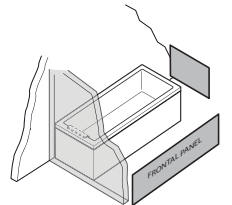
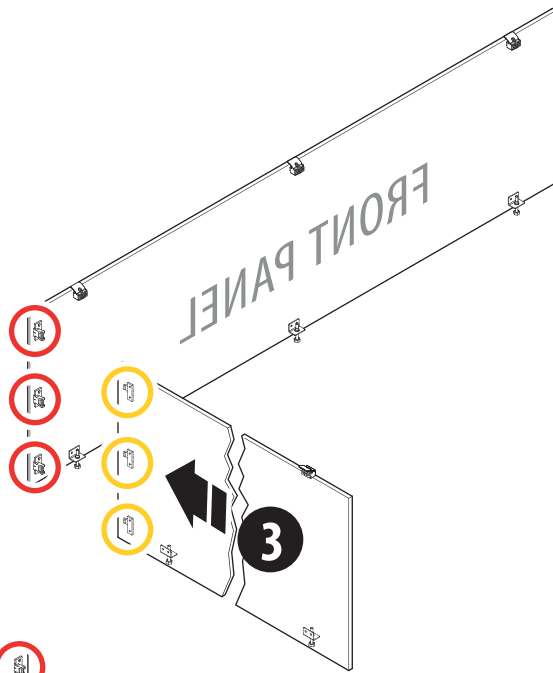
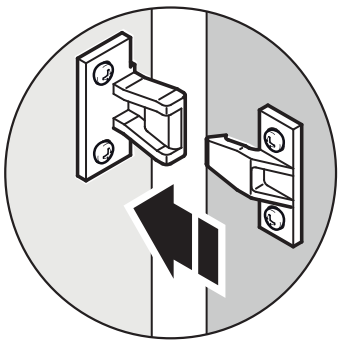
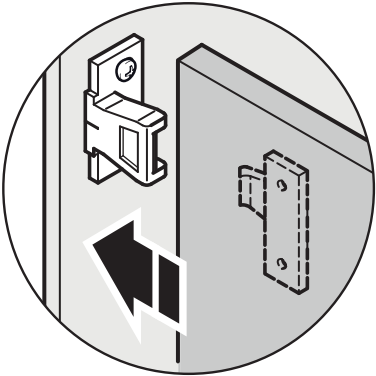
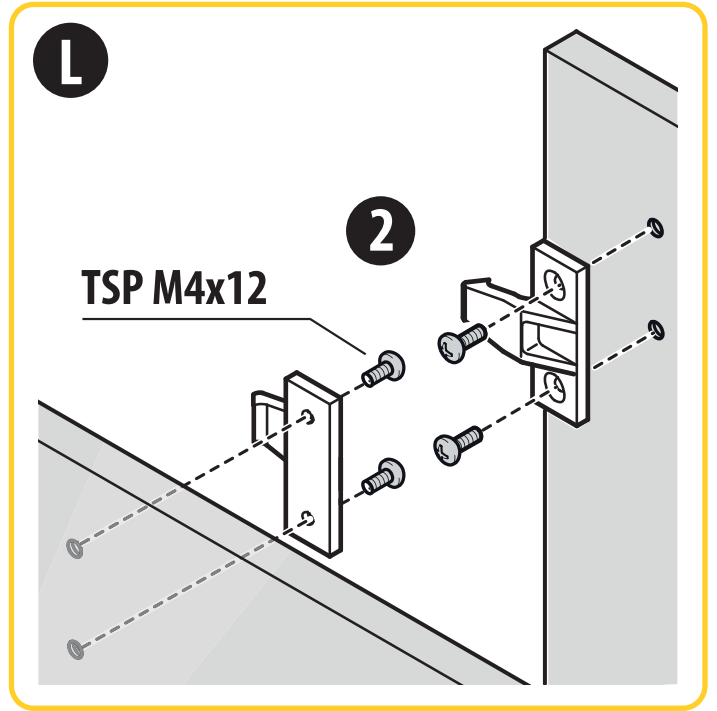
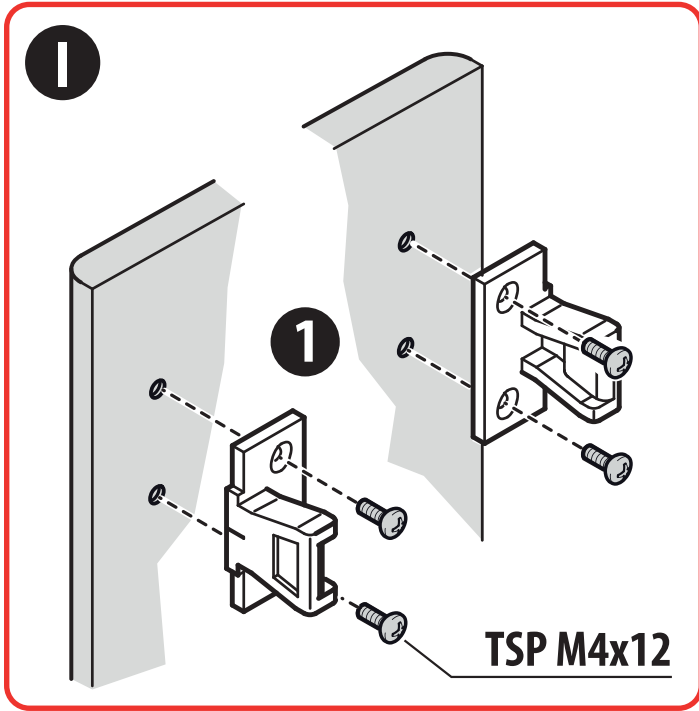

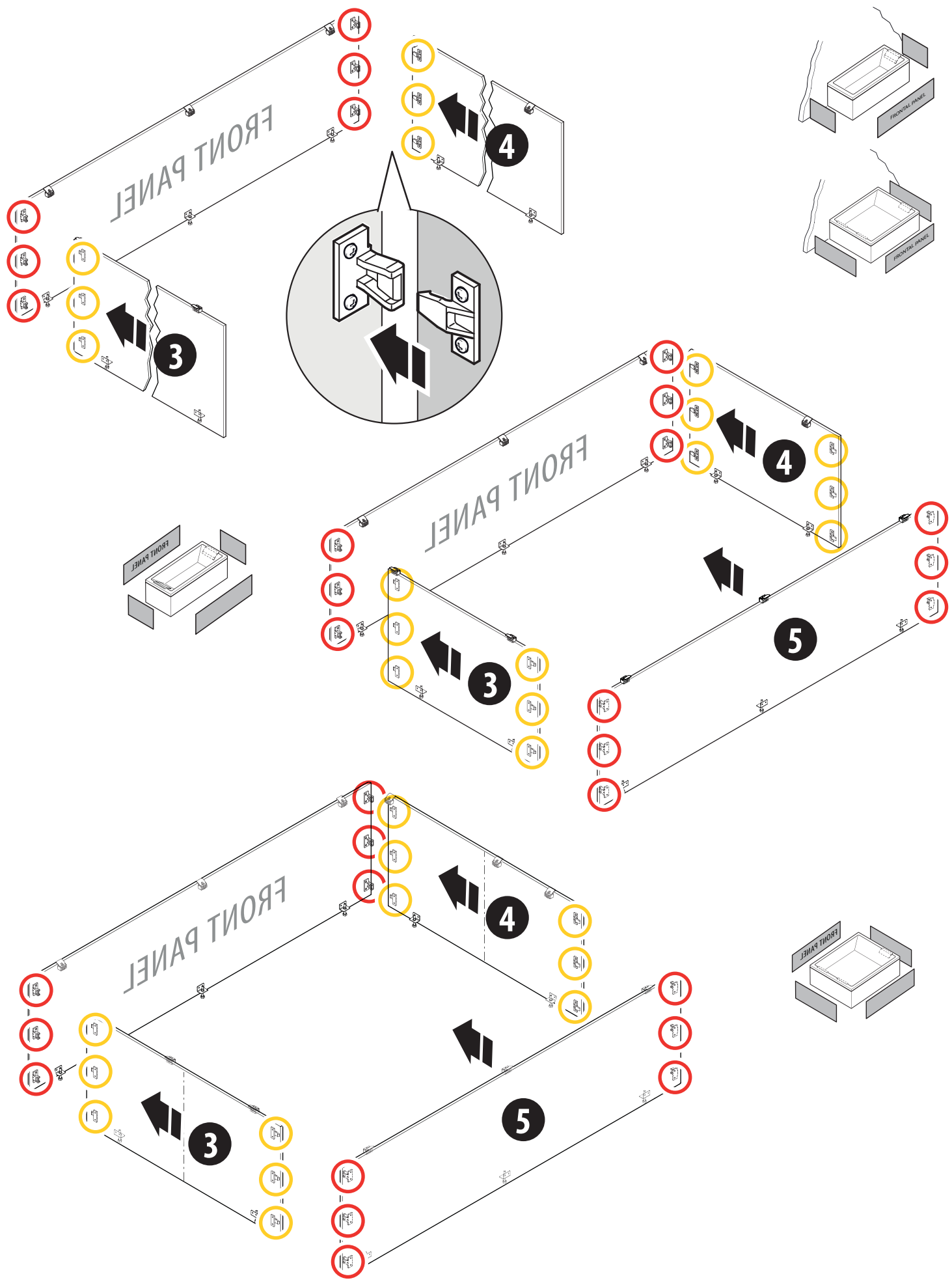

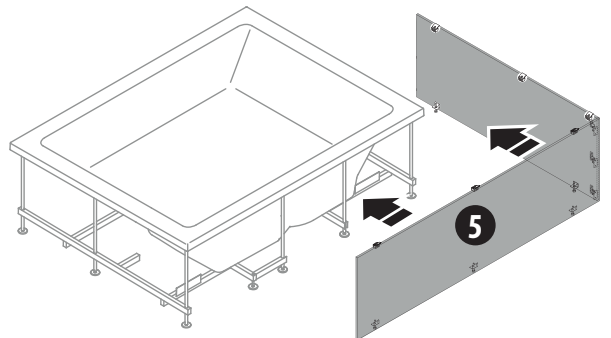
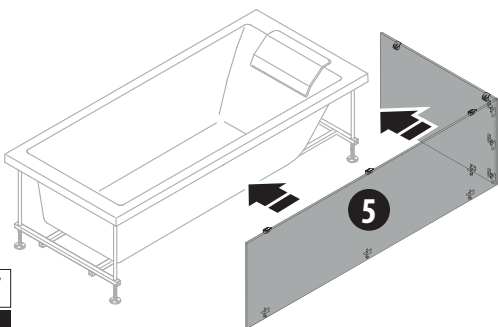
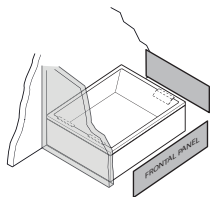
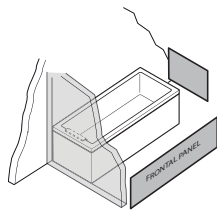
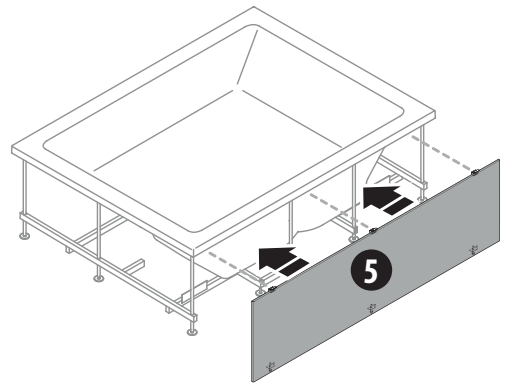
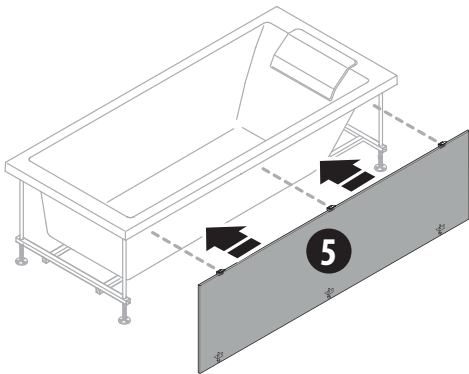
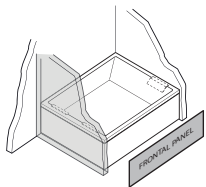
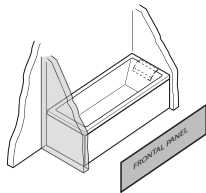
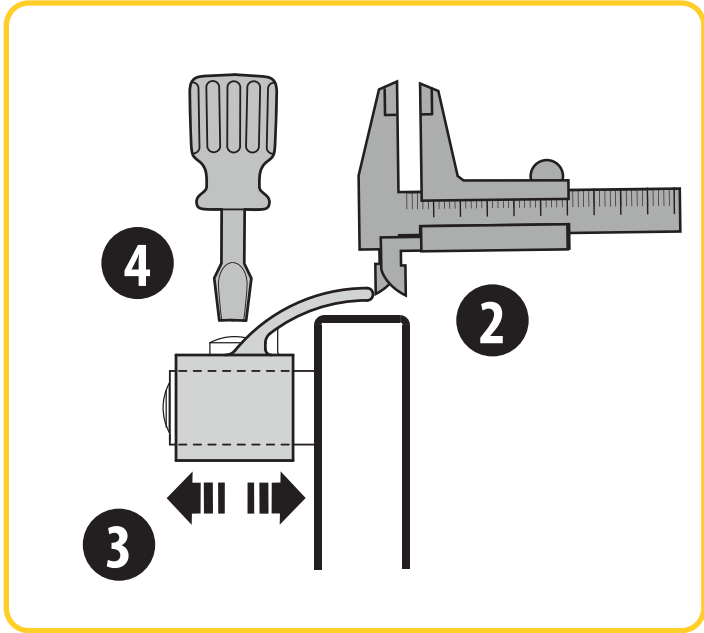
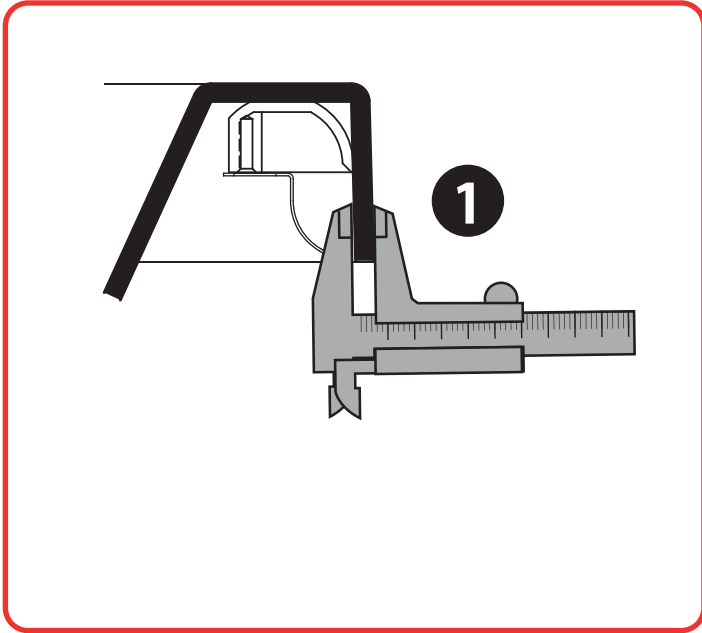

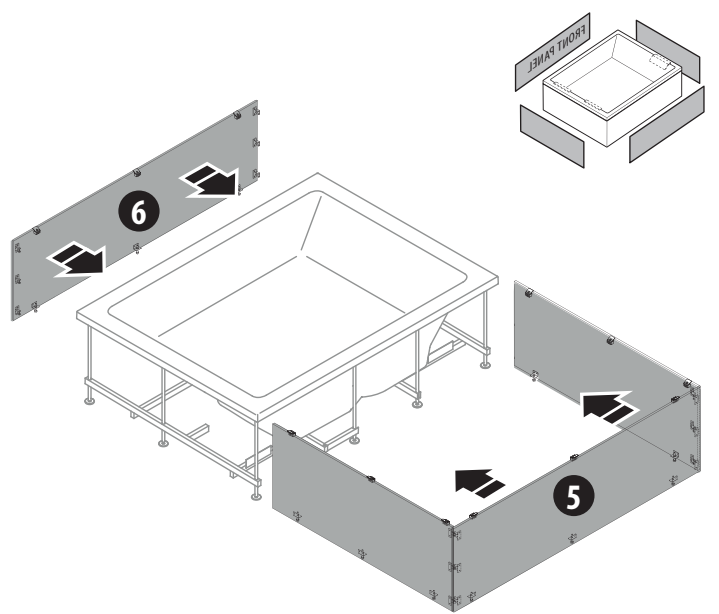
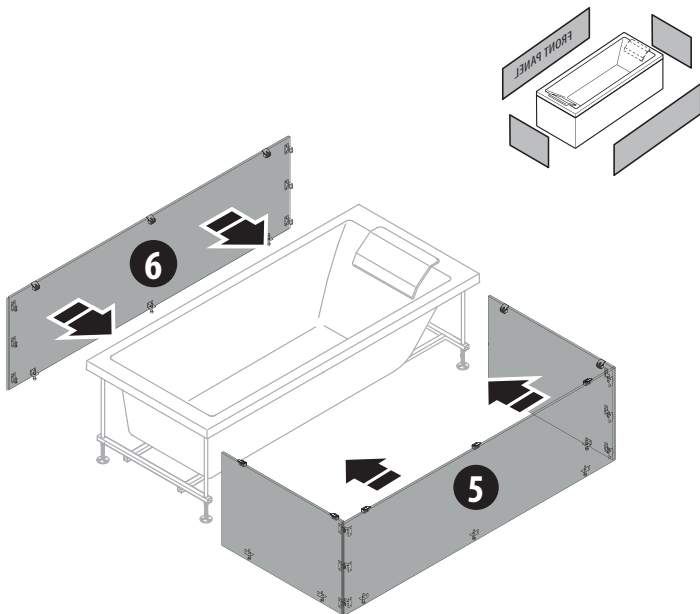
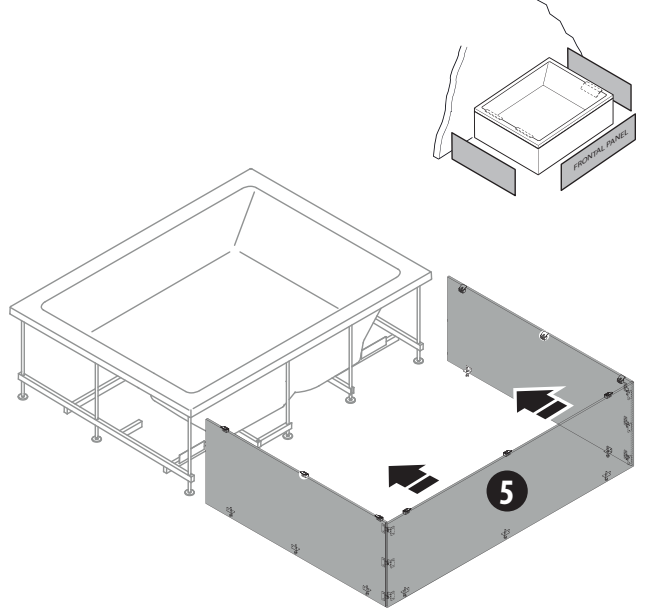
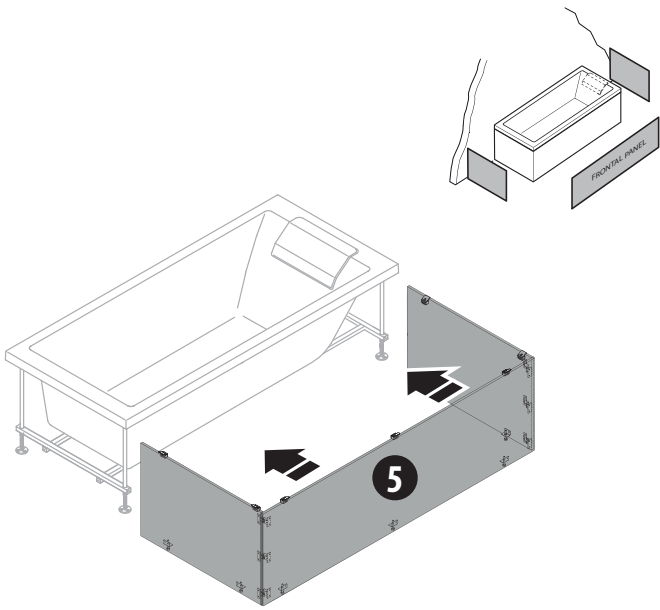
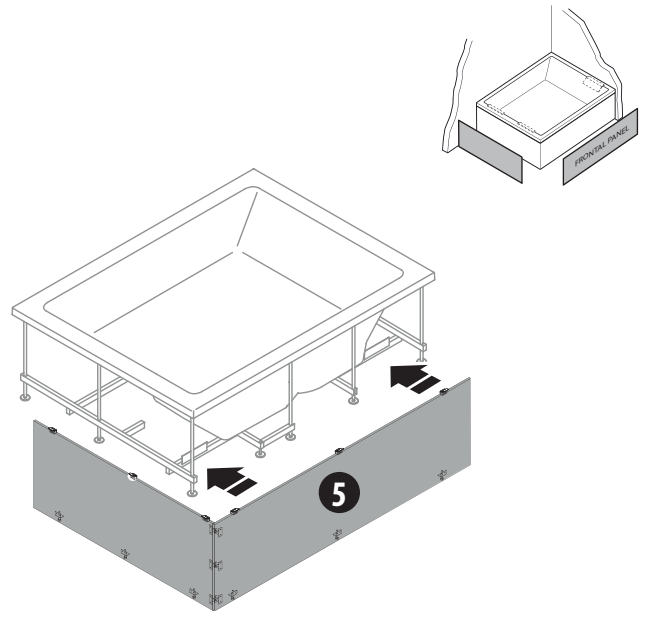
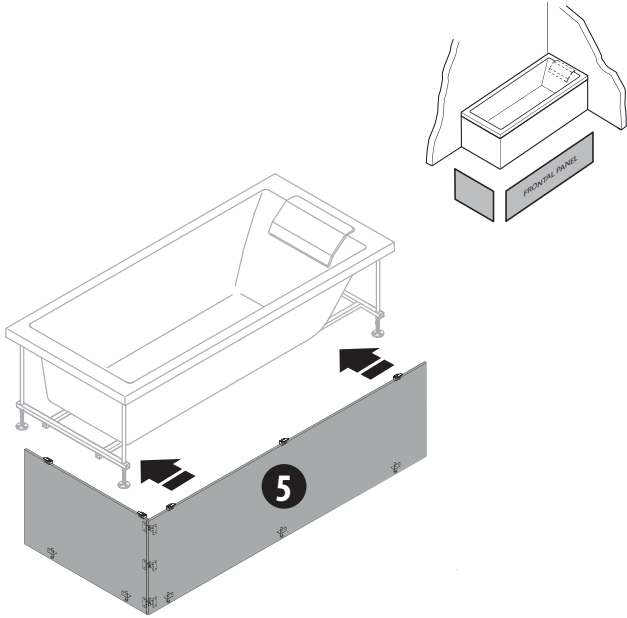

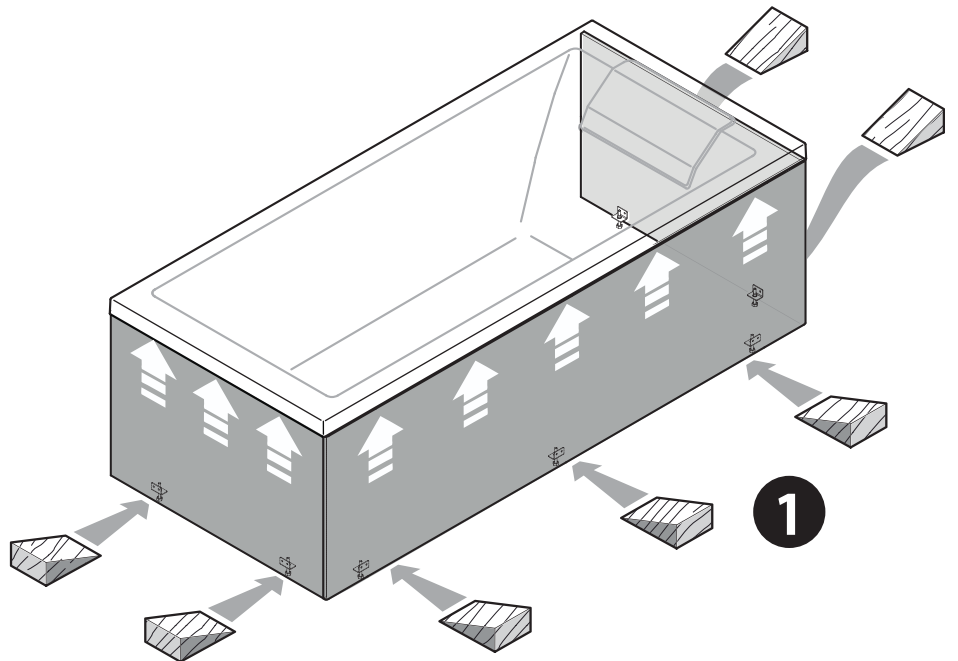
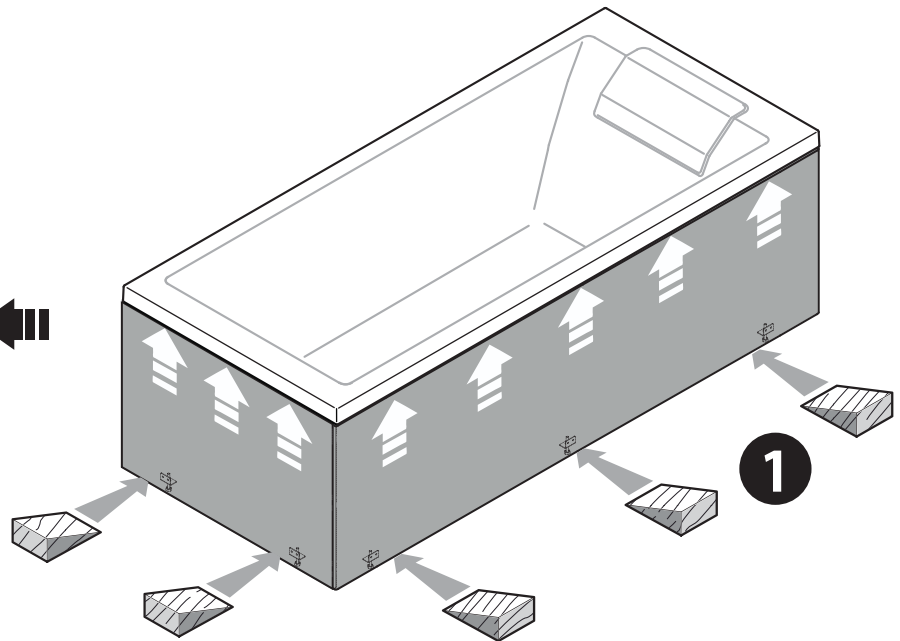
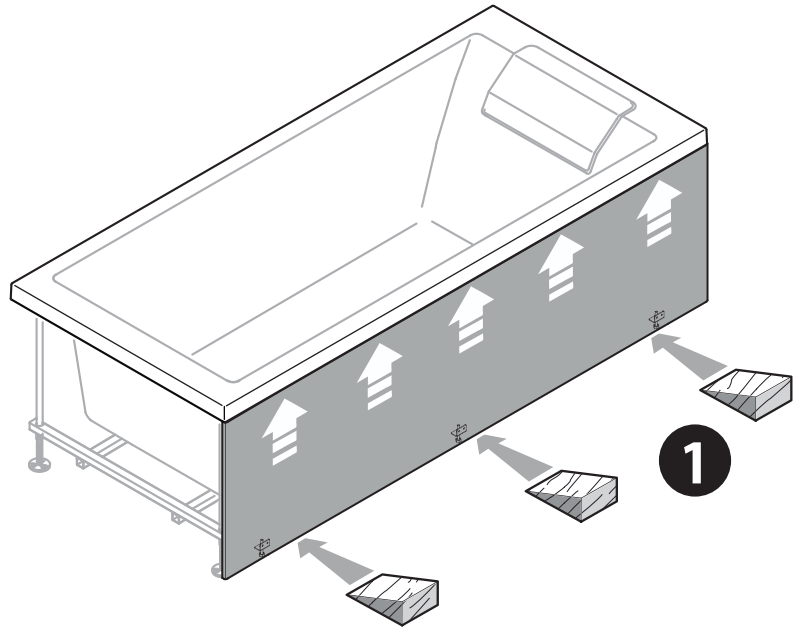
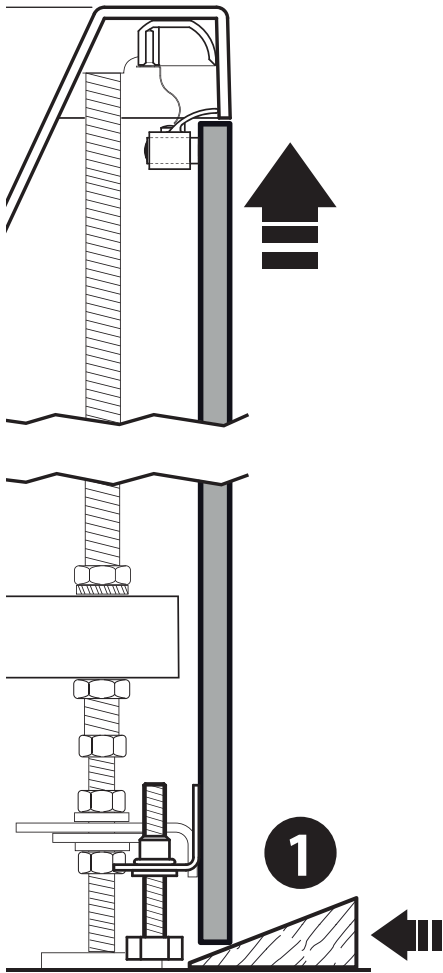

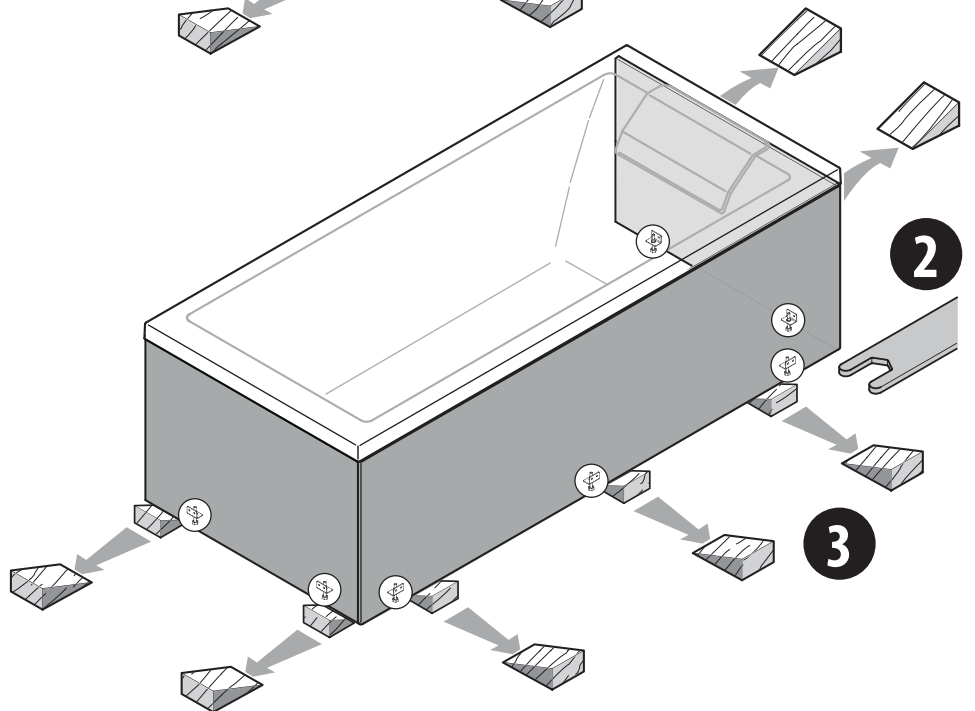
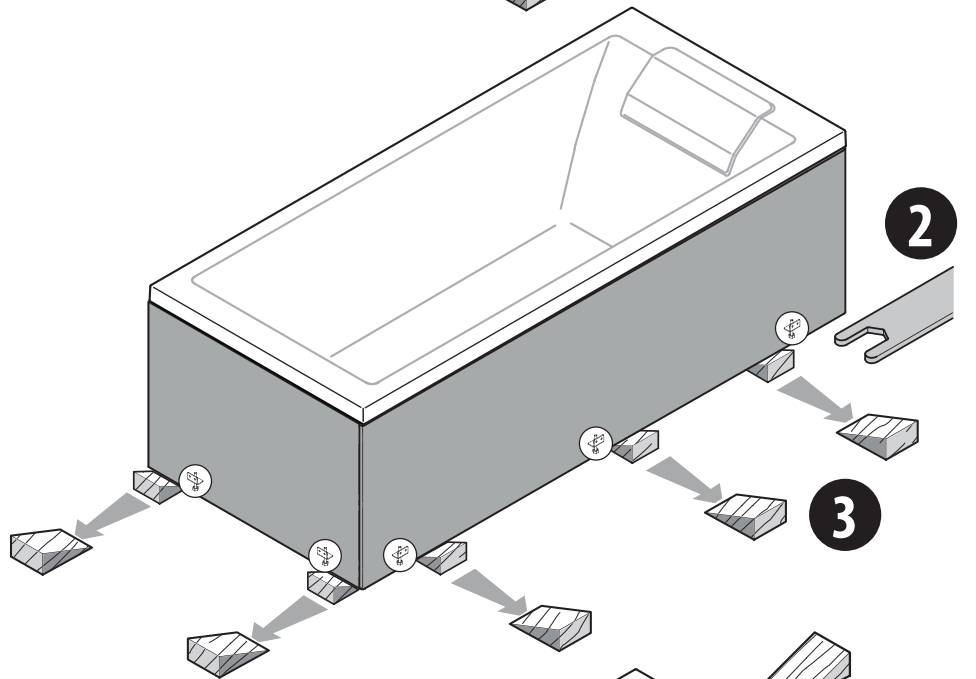
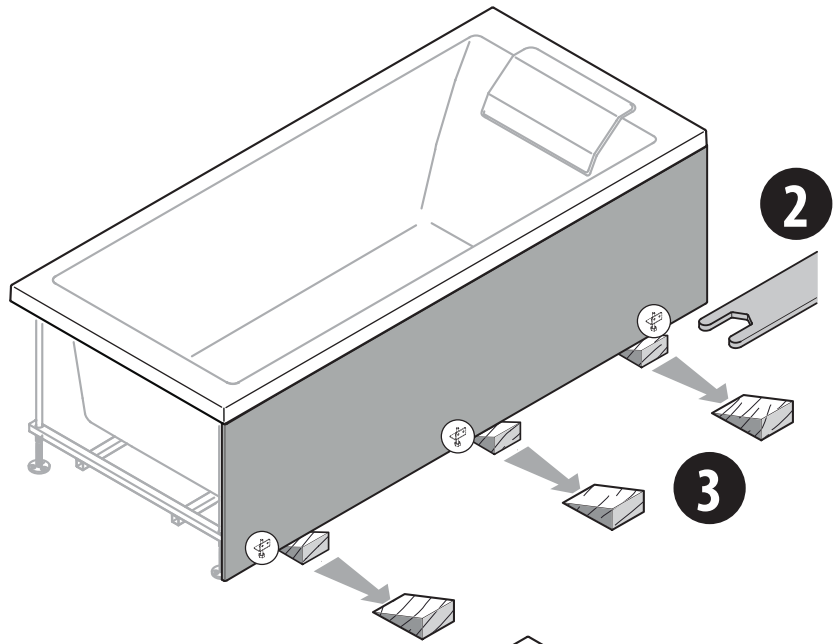
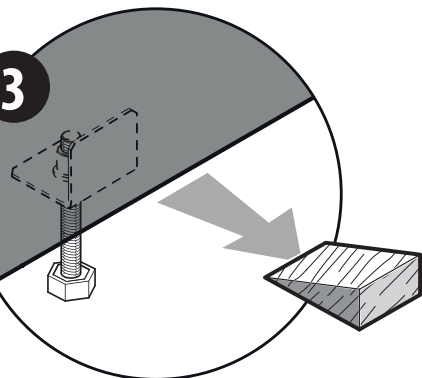
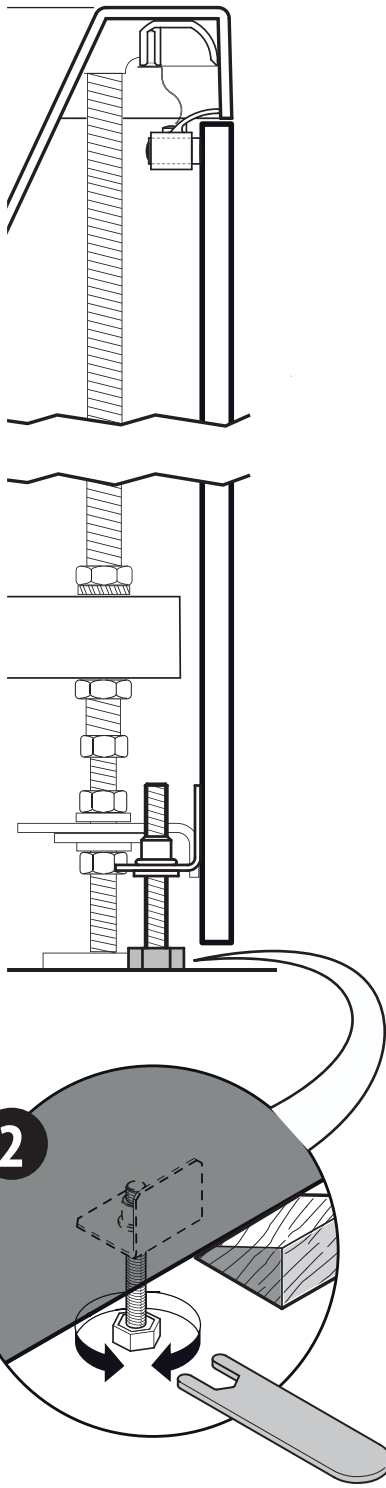

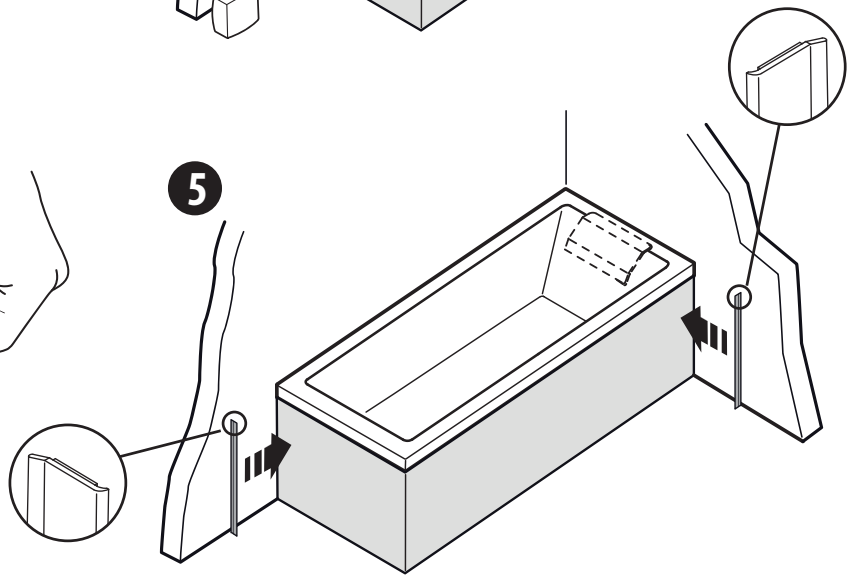
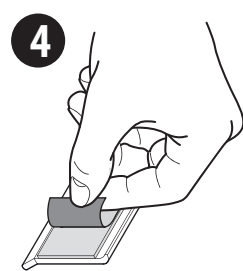
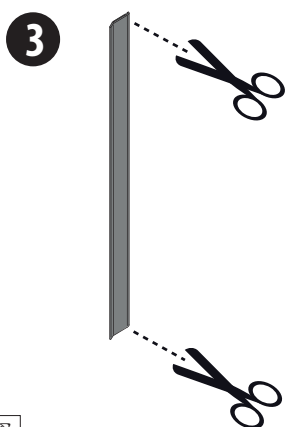
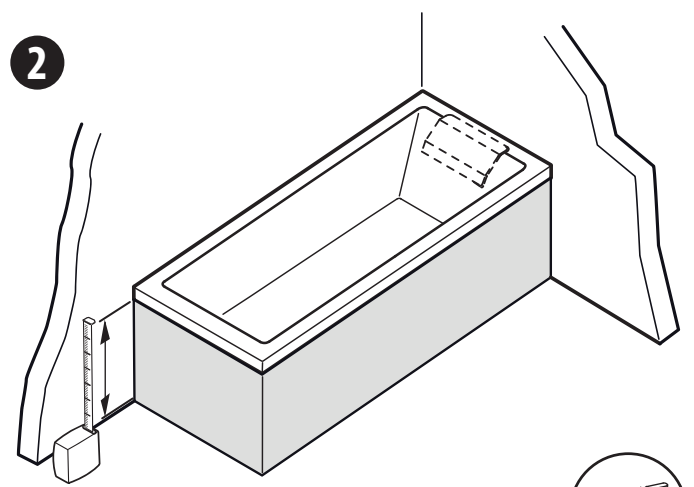
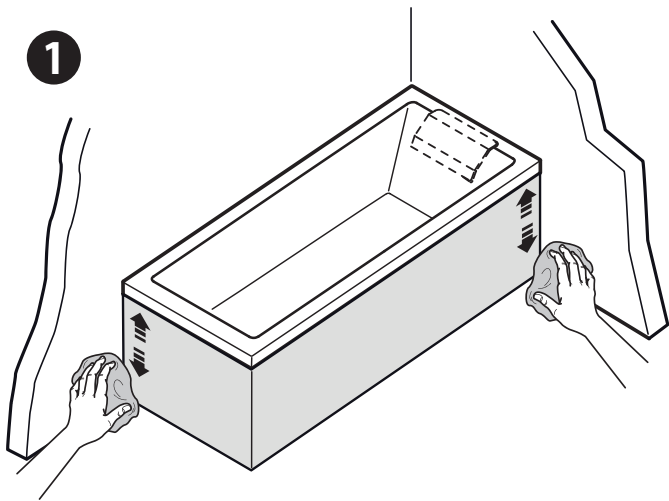
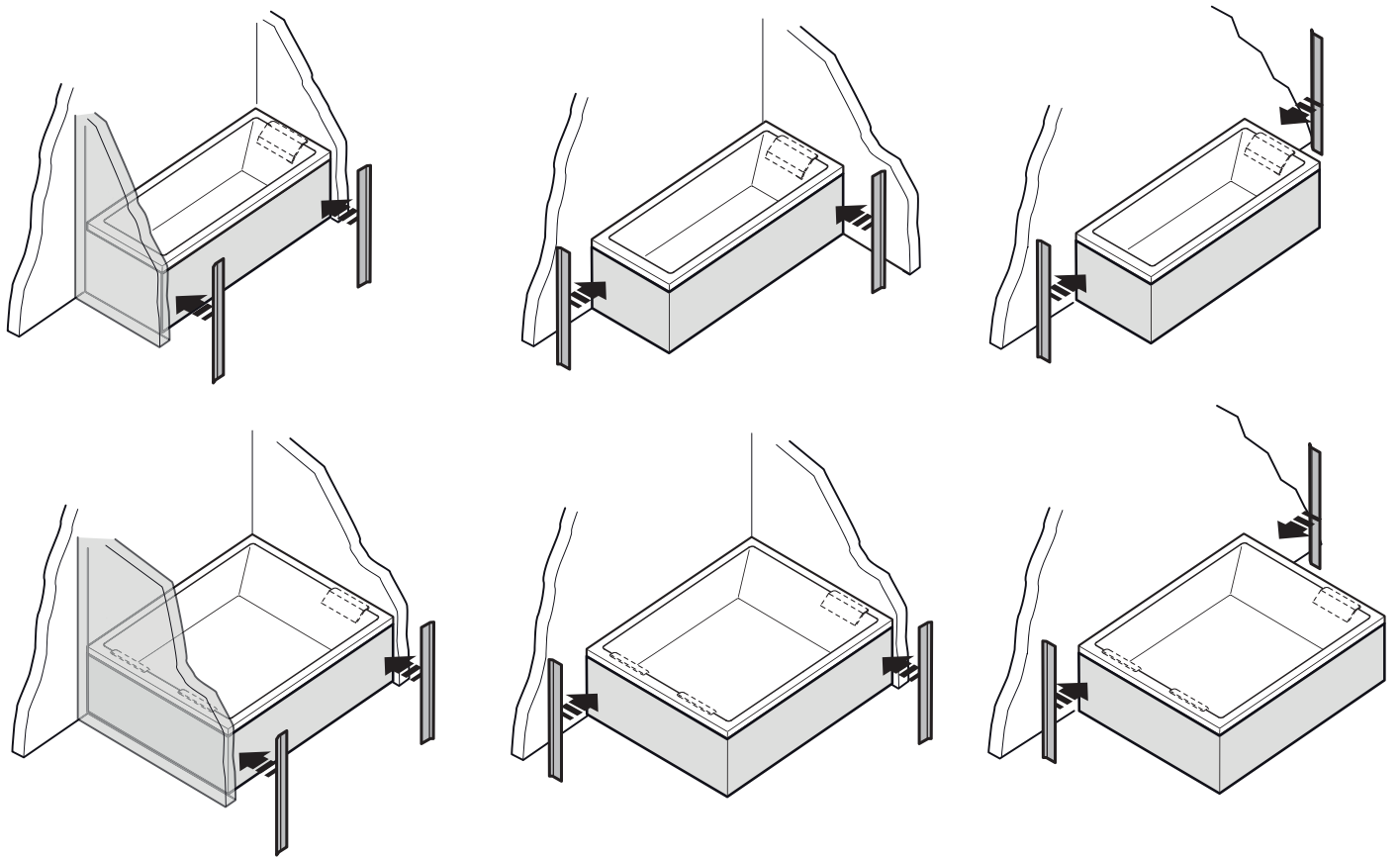



**TUTTI I MODELLI
ALL MODELS
TOUS LES MODÈLES
ALLE MODELLE
TODOS LOS MODELOS
ВСЕ МОДЕЛИ**

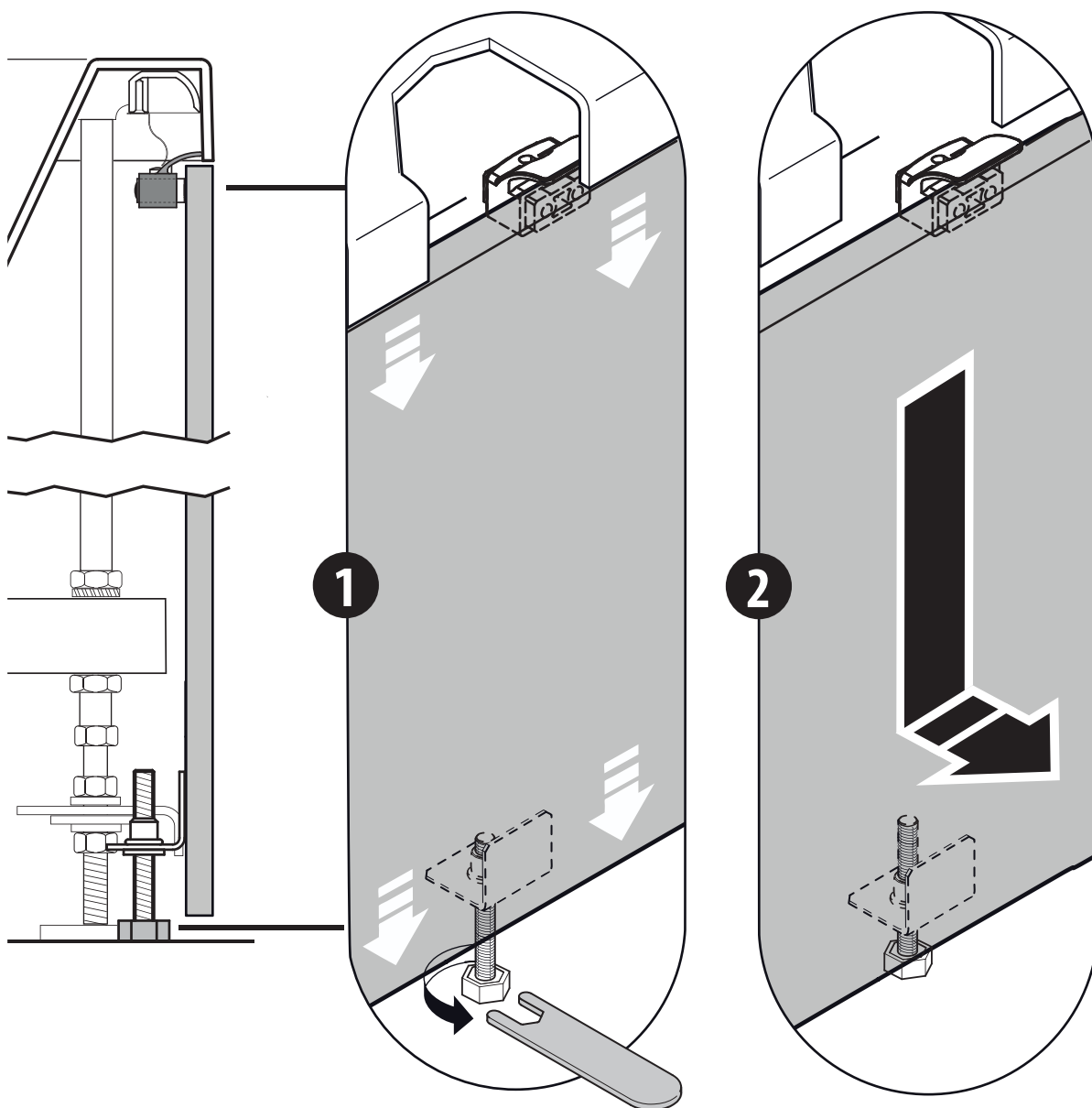
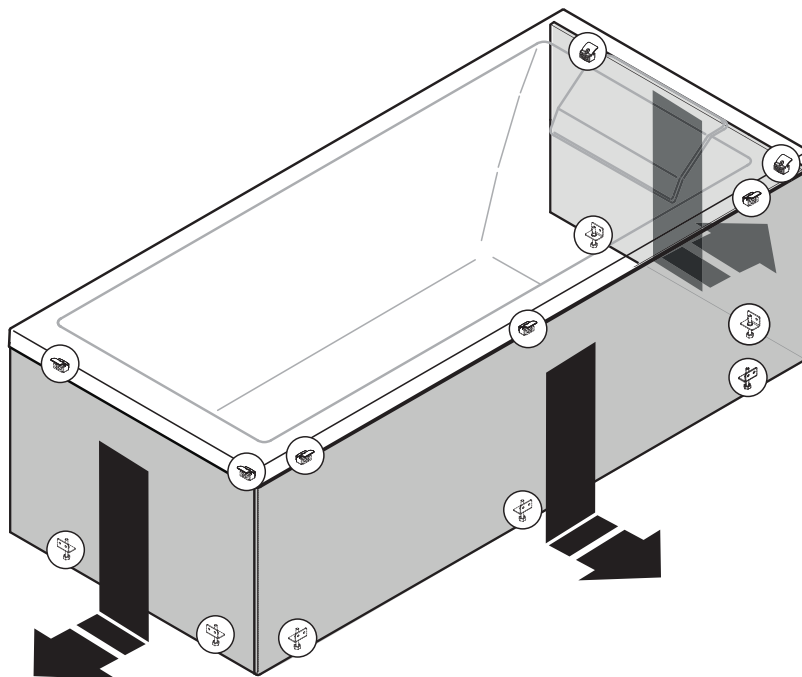

Manutenzione delle parti in legno

■ Come normale manutenzione vi consigliamo una pulizia periodica con un panno imbevuto di una soluzione di acqua e sapone. Non usate prodotti abrasivi o solventi. Per una eventuale manutenzione straordinaria vi consigliamo di rivolgervi a personale specializzato.

Maintenance of wooden parts

■ Normal recommended maintenance includes cleaning with a cloth and soapy water. Do not use abrasive products and solvents. We recommend contacting specialised personnel for supplementary maintenance, if needed.

Entretien des parties en bois

■ Pour l'entretien ordinaire, procédez à un nettoyage régulier avec un chiffon imbibé d'eau savonneuse. N'utilisez pas de produits abrasifs ou solvants. Pour un entretien extraordinaire, contactez un personnel spécialisé.

Wartung der Holzteile

■ Als normale Wartung empfehlen wir Ihnen eine regelmäßige Reinigung mit einem in Wasser und Seife eingetauchten Lappen. Benutzen Sie keine Scheuer- oder Lösungsmittel. Für eine eventuelle außergewöhnliche Wartung empfehlen wir Ihnen, sich an spezialisiertes Personal zu wenden.

Mantenimiento de las partes de madera

■ Como medida de mantenimiento normal aconsejamos una limpieza periódica con un paño embebido con una solución de agua y jabón. No usar productos abrasivos o solventes. Si fuera necesario un mantenimiento extraordinario, le aconsejamos dirigirse a personal especializado.

Уход за деревянными поверхностями

■ Рекомендуем периодически протирать поверхность деревянных деталей мягкой тряпкой, смоченной в мыльной воде. Не используйте абразивные материалы или растворители. В особых случаях рекомендуем обращаться за консультацией к специализированному персоналу.



JACUZZI EUROPE S.p.A.

Socio Unico

Direzione e Coordinamento

Jacuzzi Brands, Corp. (USA)

S.S. Pontebbana, km 97,200

33098 Valvasone Arzene (PN) ITALIA

Phone + 39 0434 859111- Fax + 39 0434 85278

www.jacuzzi.eu - info@jacuzzi.eu



Jacuzzi UK

Jacuzzi® Spa and Bath Ltd

Old Mill Lane - Low Road - Hunslet

Leeds LS10 1RB

Jacuzzi® Hot tubs: hottubsales@jacuzziemea.com

Jacuzzi® Bathrooms: retailersales@jacuzziemea.com

Phone: +44 (0)113 2727430 - Fax: +44 (0)113 2727445

Jacuzzi Whirlpool GmbH

A Company of Jacuzzi Brands, Corp. (USA)

Humboldtstr. 30/32

D-70771 Leinfelden-Echterdingen

Phone: 0049 (0)711 933247-20 Technik/Service/Kundendienst/Ersatzteile (After Sales)

Phone: 0049 (0)711 933247-40 Verkauf/Preise/Finish Products

Fax 0049 (0)711 933247-50

www.jacuzzi.eu

info-de@jacuzzi.eu

Jacuzzi France s.a.s.

8 Route de Paris

03 300 Cusset Cedex (FRANCE)

Phone: +33 (0)4 70 30 90 50 - Fax: +33 (0)4 70 97 41 90

info@jacuzzi-france.com

Jacuzzi Bathroom España, SL

Sociedad unipersonal

A Company of Jacuzzi Brands, Corp. (USA)

Jacuzzi® Bathroom España

C/ Comte urgell, 252 local 4

08036 Barcelona

Phone: +34 932 385 031- Fax +34 932 385 032

www.jacuzzi.es

info-es@jacuzzi.eu

I dati e le caratteristiche non impegnano la Jacuzzi Europe S.p.A., che si riserva il diritto di apportare tutte le modifiche ritenute opportune senza obbligo di preavviso o di sostituzione

The data and characteristics indicated do not oblige Jacuzzi Europe, who reserves the right to make the necessary changes they feel opportune without forewarning or substitution

Les caractéristiques indiquées, n'engagent pas la Jacuzzi Europe, qui se réserve le droit d'apporter toutes les modifications qu'elle jugera opportune sans obligation de préavis ou de remplacement

Die Angaben sind für Jacuzzi Europe nicht bindend. Änderungen, die dem Fortschritt dienen, halten wir uns vor

Los datos y características indicadas no comprometen a Jacuzzi Europe que se reserva el derecho de aportar todas las modificaciones que considere oportunas sin obligación de preaviso o de sustitución

Приведенные данные и характеристики являются для фирмы Jacuzzi Europe S.p.A. необязательными. Фирма оставляет за собой право внесения всех тех изменений, которые будут признаны необходимыми, без обязательства предварительного уведомления или замены.



220109343

JACUZZI EUROPE S.p.A. • all rights reserved • MAY 2016

