

# Elm A1

**General notes**

Kast work to tolerances of +/-5mm, Joints 3-5mm, vertical deflection 3mm per linear meter. It is the responsibility of the recipient (client) to check all dimensions are correct and confirm prior to manufacture. Kast will manufacture from only from these drawings on receipt of client confirmation and takes no responsibility for incorrect dimensions and measurements not reported. This drawing is to be viewed in conjunction with all other contract documentation and specifications and all other consultants drawings. All dimensions should be checked and any discrepancies notified to Kast prior to proceeding with works any discrepancies found between this drawing and other documents should be referred immediately to Kast. The author takes no responsibility for any dimensions obtained by scaling from this drawing.

**Plan View**

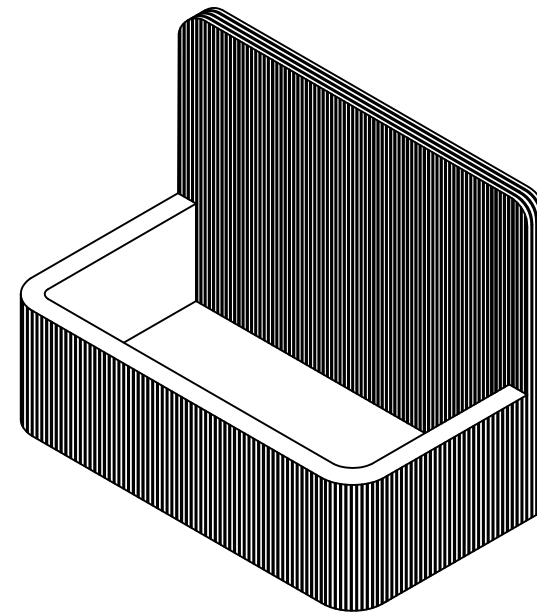
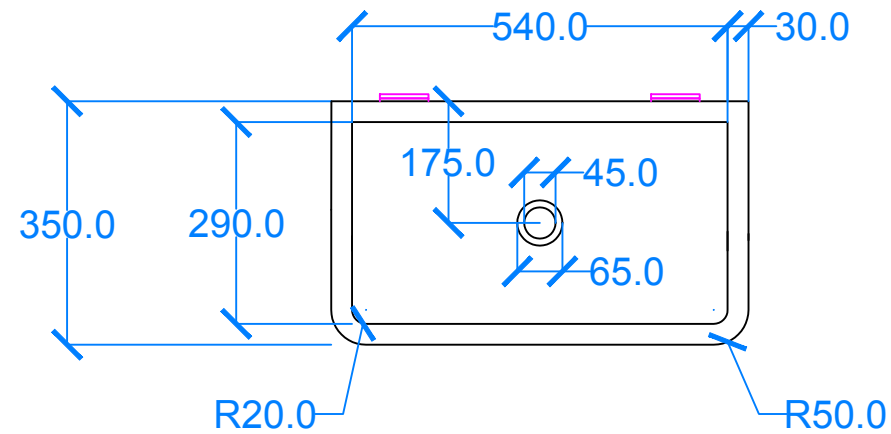

**Side View**

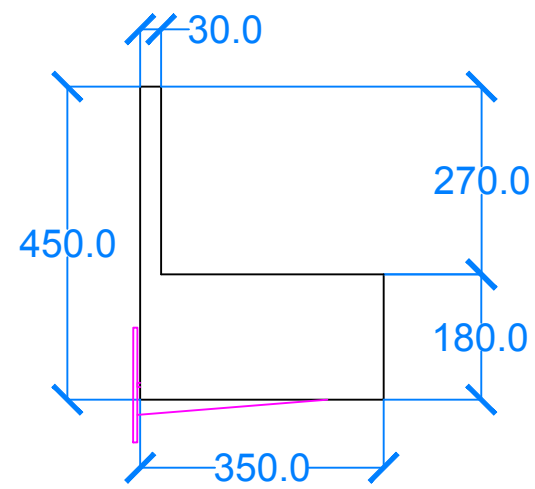

**Back View**

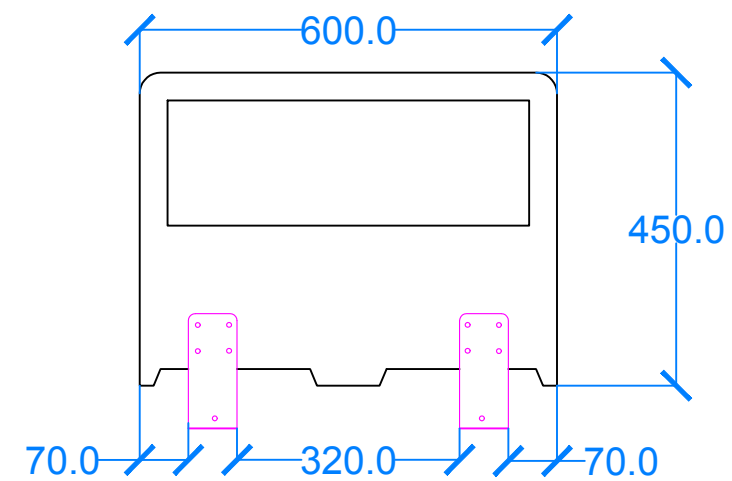

**Front View**

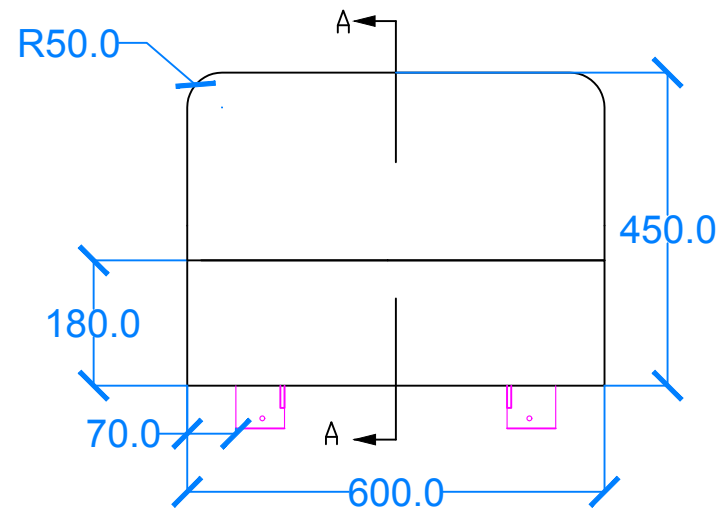

**Section A-A**

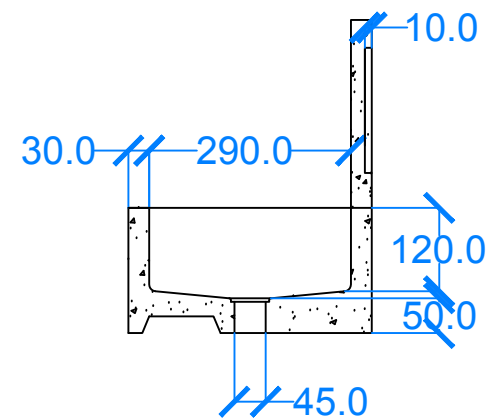

**Underside View**

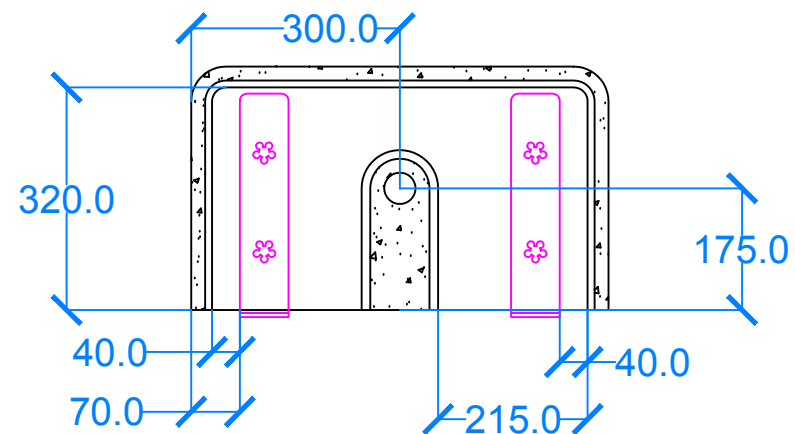

Basin Description  
L600 x W350 x H450mm  
30mm walls

Drawn by GR	Scale NA	Basin Code E.A1
----------------	-------------	--------------------

**Kast**  
concrete basins

Kast Concrete Basins Ltd  
Meden Court  
Boughton Industrial Est  
Nottingham NG22 9YU

Tel 056 0384 0595  
Email [Info@kastconcretebasins.com](mailto:Info@kastconcretebasins.com)  
Web [www.kastconcretebasin.com](http://www.kastconcretebasin.com)