

T80Z Fast-Fit

The T80Z Fast-Fit has taken ease of installation to new levels with flexibility in both plumbing and wiring connections making it the only shower you need in the van.

INSTALLATION BENEFITS

Replacements

Ideal size and shape for replacement installations.

Flexible Electric Connections Swing-Fit™

Unique Swing-Fit™ terminal block allows left or right hand wiring connections.

Flexible Water Connections Swivel-Fit™

Unique Swivel-Fit™ 180° fully reversible swivel water inlet accommodates water connections from either the left or the right hand side of the unit.

Flexible Kit

Adjustable distance between shower rail fixings.

Installation Template

Eases marking of fixing holes and connections for easy fittings.

2 Year Guarantee

Simply fit and forget.

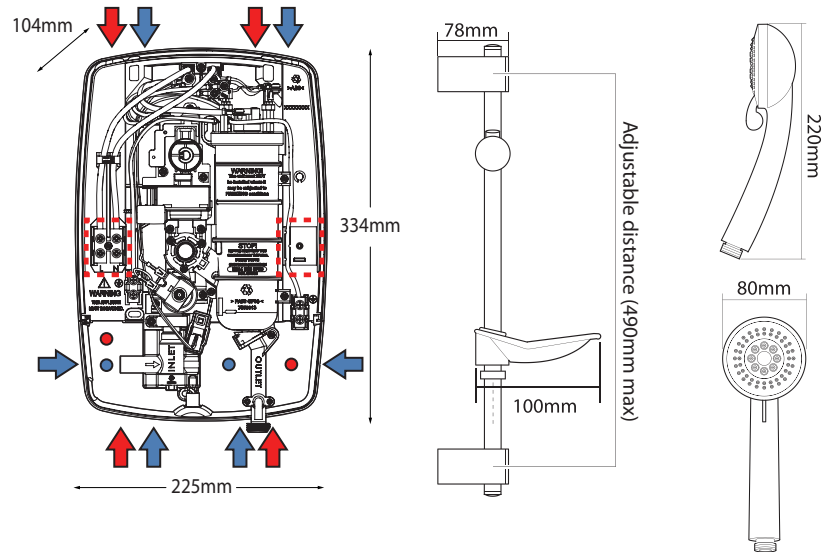

Entry Points

➔ Water entry points
 ➔ Cable entry points
 Swing-Fit™ terminal positions

All dimensions are approximate

TECHNICAL INFORMATION

Temperature Control	Temperature stabilised
Power Ratings	7.5kW, 8.5kW, 9.5kW, 10.5kW
Inlet Connection	15mm Compression
Water Entry Points	Top, bottom, side bottom, back (left hand side unit) Top, bottom, side bottom, back (right hand side unit)
Cable Entry Points	Top, bottom, back (left hand side unit) Top, bottom, back (right hand side unit)
Outlet Connection	½" BSP
Plumbing System	Cold mains fed water only
Minimum Running Pressure/ Flow for Full Performance	1 Bar @ 8 l/min and 1.5 Bar @ 11 l/min for 10.5 kW* Eco model maximum 6l/min
Maximum Static Pressure	10 bar
Surface Mounted Only	
Approvals	Complies with BEAB, CE, BSI Kitemark
Guarantee	2 years

*At running pressure/flow 0.7 Bar at 8 l/min (1.2 Bar at 11 l/min for 10.5kW) the shower will continue to operate at a reduced performance.



White/Chrome



Chrome



White/Chrome Eco Model

DID YOU KNOW?

The revolutionary Swing-Fit™ terminal block for left or right cabling is only in the T80Z Fast-Fit.

**TRITON
T:ME**



T80Z Fast-Fit

T80Z FAST-FIT MODELS

CODE	DESCRIPTION
SP8007ZFF	T80Z Fast-Fit 7.5kW White/Chrome
SP8008ZFF	T80Z Fast-Fit 8.5kW White/Chrome
SP8009ZFF	T80Z Fast-Fit 9.5kW White/Chrome
SP8001ZFF	T80Z Fast-Fit 10.5kW White/Chrome
SP8CHR8ZFF	T80Z Fast-Fit 8.5kW Chrome
SP8CHR9ZFF	T80Z Fast-Fit 9.5kW Chrome
SP8CHR1ZFF	T80Z Fast-Fit 10.5kW Chrome
ECO8008ZFF	Eco T80Z Fast-Fit 8.5kW White/Chrome

