

# Technical Data Sheet

Marston Basin Taps (Pair)

No.	Description	Fixings Included
1	Marston Basin Taps (Pair)	YES



Min Pressure:	0.2bar
0.2bar	5 litres / min
0.3bar	6.2 litres / min
0.4bar	7.5 litres / min
0.5bar	8.5 litres / min
1bar	12.5 litres / min
2bar	17 litres / min

## Dimensions:

Diagrams not to scale. All dimensions in mm (tolerance of +/-5mm)

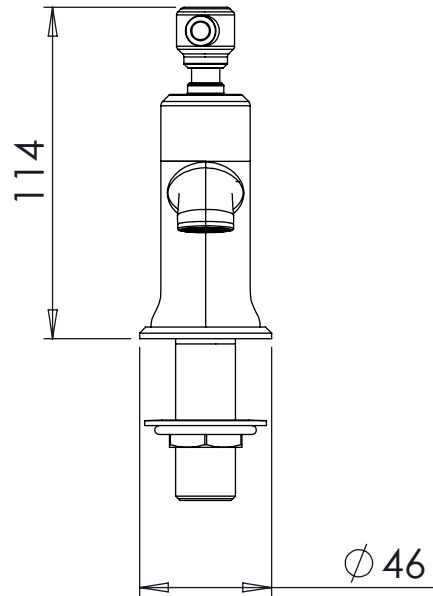
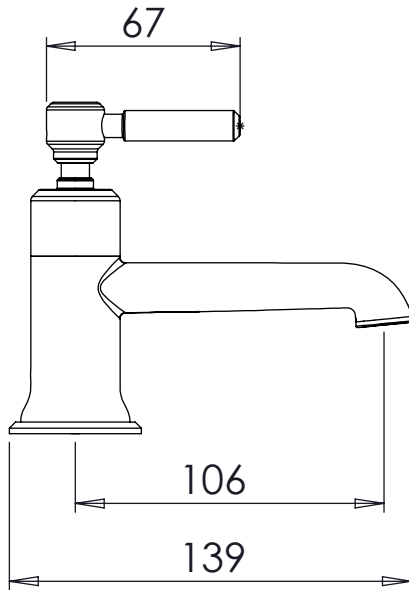

\*Dimensions are subject to change, customers are advised to measure actual product before commencing installation.

## FAQs

What is the size of the tap threaded connection? The threaded inlet is 1/2" BSP

**Does the tap come fitted with an aerator?** Yes, the aerator comes pre-installed but can be replaced.