

C51-F450-01	43212XXX
C51-F660-02	43213XXX
C51-F450-03	43214XXX
C51-F635-04	43215XXX
C51-F770-05	43216XXX
C51-F450-06	43217XXX
C51-F660-07	43218XXX
C51-F450-08	43219XXX
C51-F635-09	43220XXX
C51-F770-10	43221XXX
C51-F450-11	43227XXX
C51-F450-12	43228XXX
S510-F450	43312XXX/43318XXX
S510-F450	43322XXX/43323XXX
S510-F660	43313XXX/43319XXX
S510-F660	43324XXX/43325XXX
S510-F635	43315XXX
S514-F450	43314XXX
S510-F770	43316XXX/43321XXX
S510-F770	43328XXX/43329XXX
S510-F760	43317XXX/43320XXX
S510-F760	43326XXX/43327XXX
S5110-F450	43330XXX
S520-F345	43356XXX
S520-F530	43357XXX
S520-F480	43358XXX
S520-F510	43359XXX
S510-U450	43431XXX/43437XXX
S510-U450	43441XXX/43442XXX
S510-U660	43432XXX/43438XXX
S510-U660	43443XXX/43444XXX
S510-U660	43451XXX
S510-U635	43433XXX
S510-U760	43436XXX/43439XXX
S510-U760	43445XXX/43446XXX
S510-U770	43434XXX/43440XXX
S510-U770	43456XXX
S510-U770	43447XXX/43448XXX

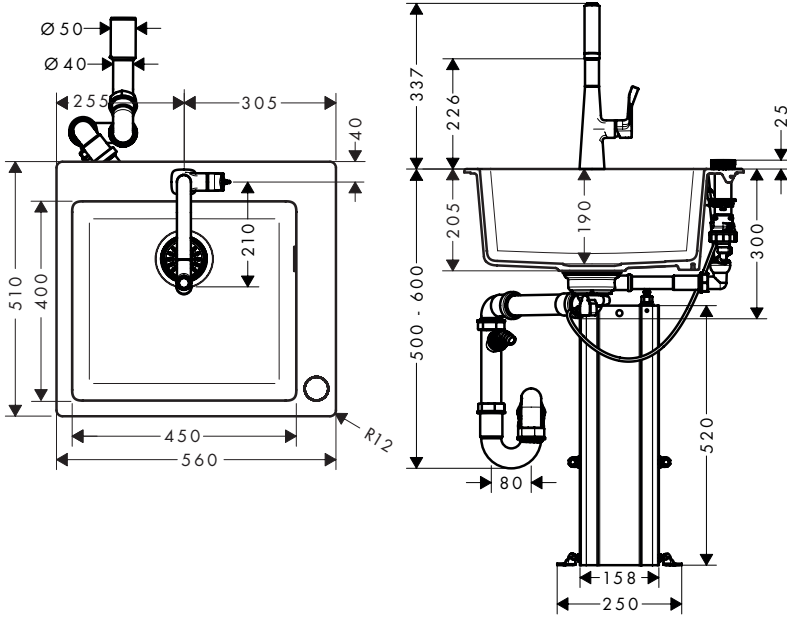

C51-F450-01 43212XXX



C51-F660-02 43213XXX

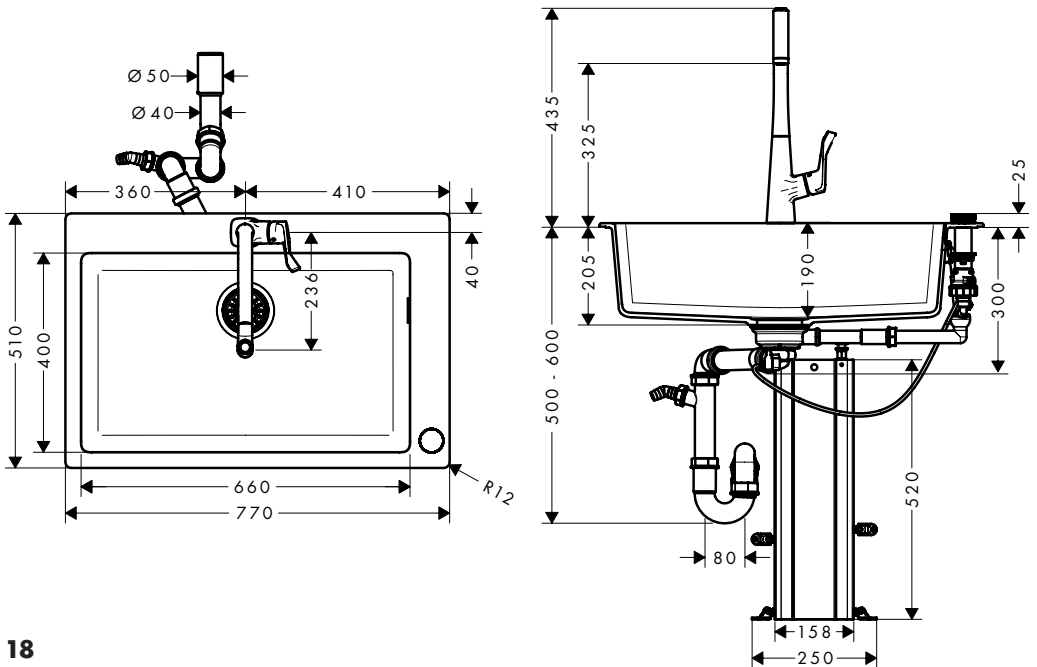

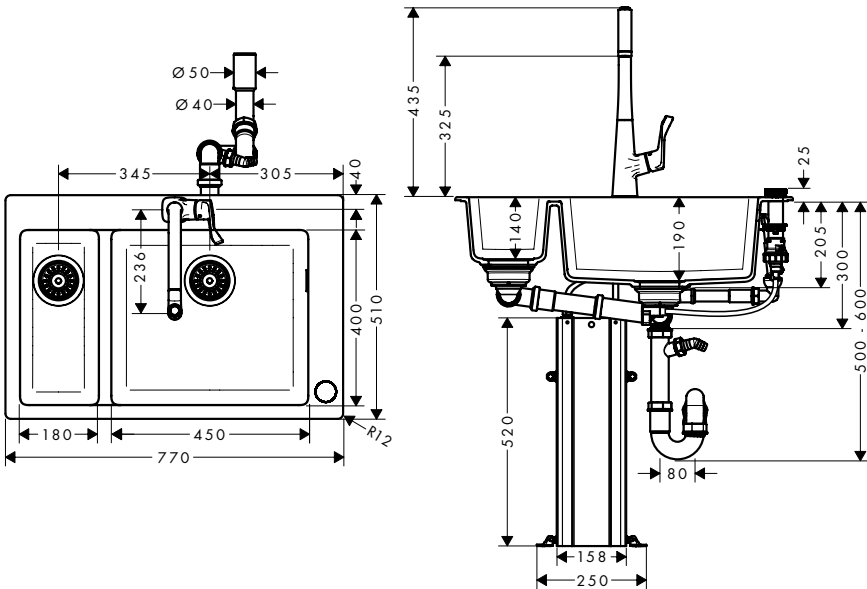
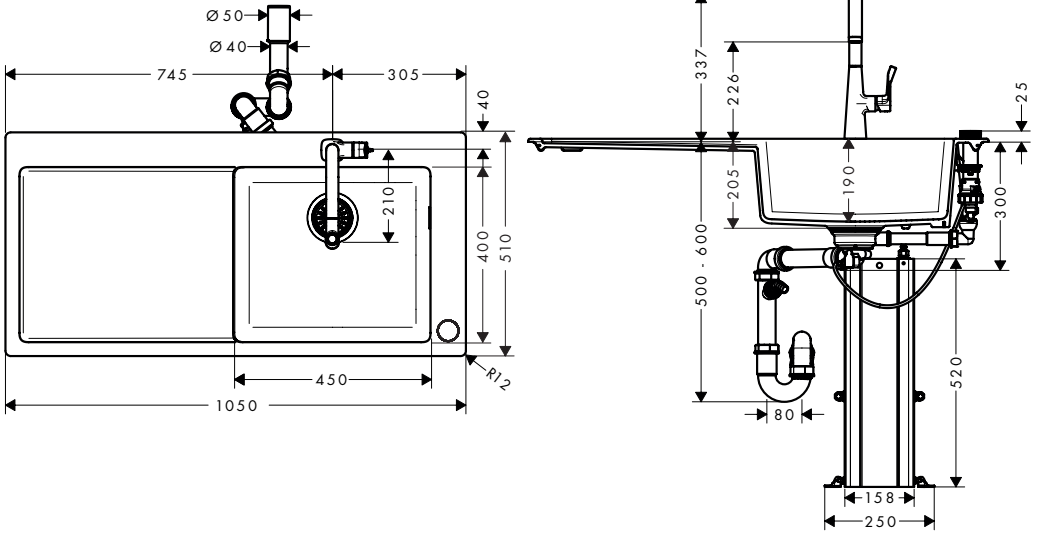

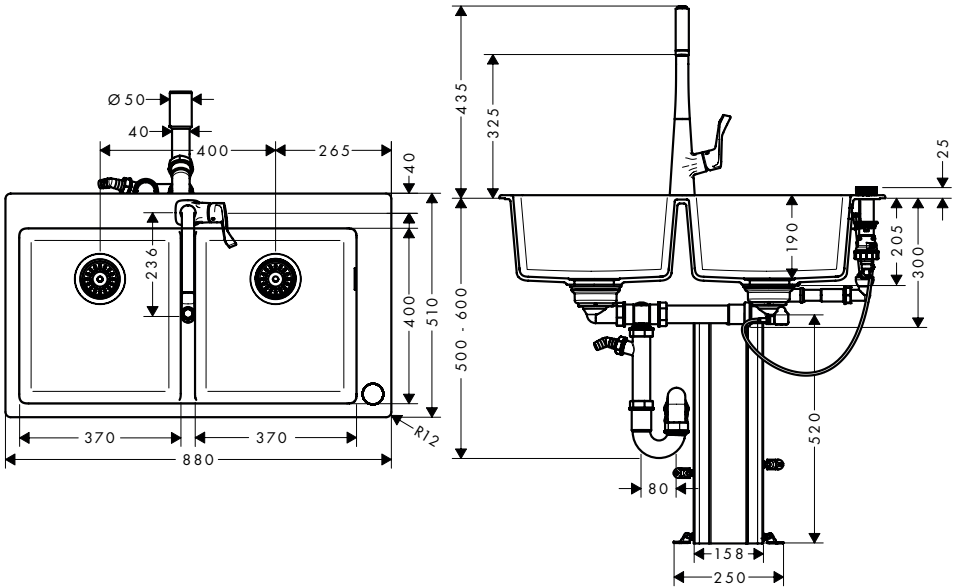
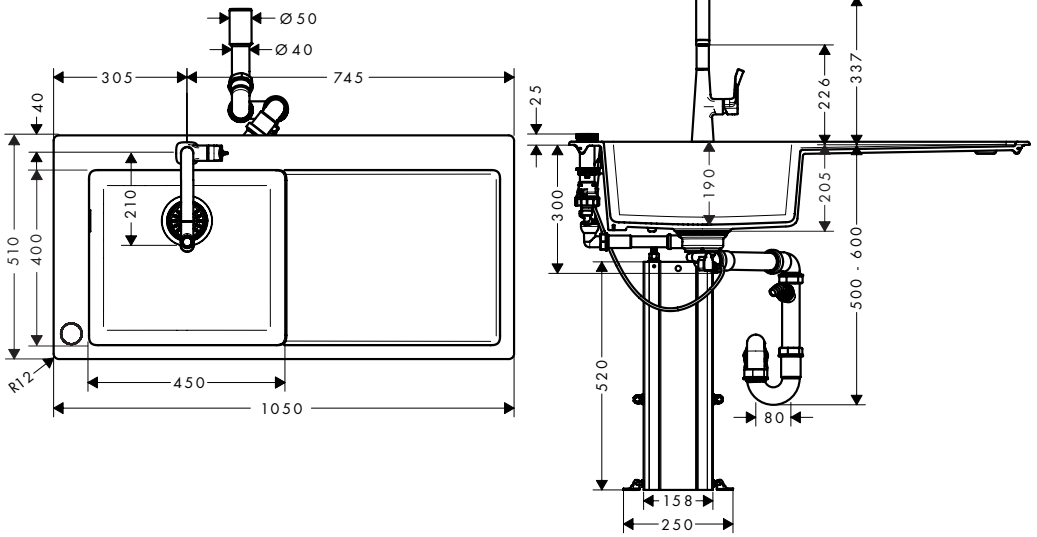

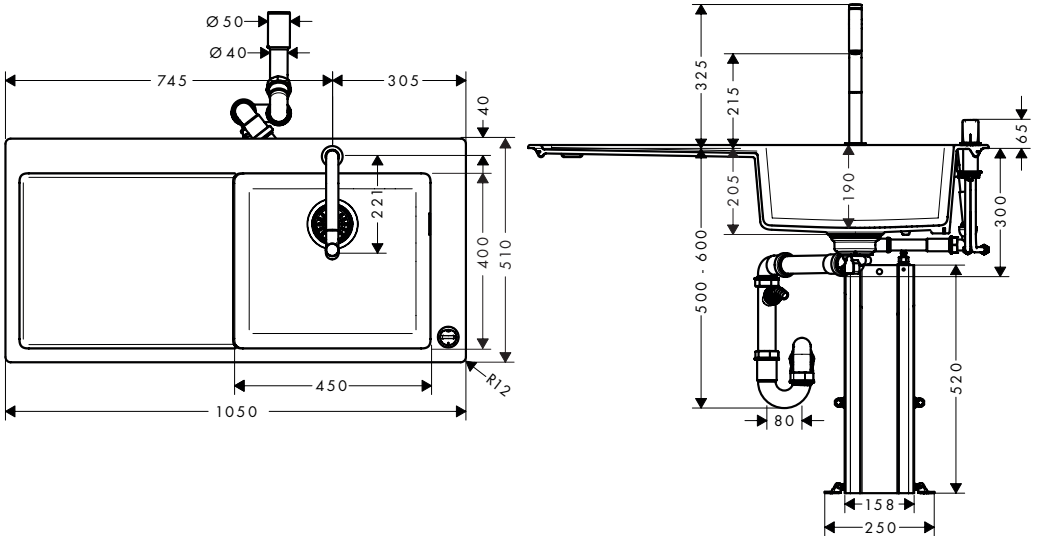
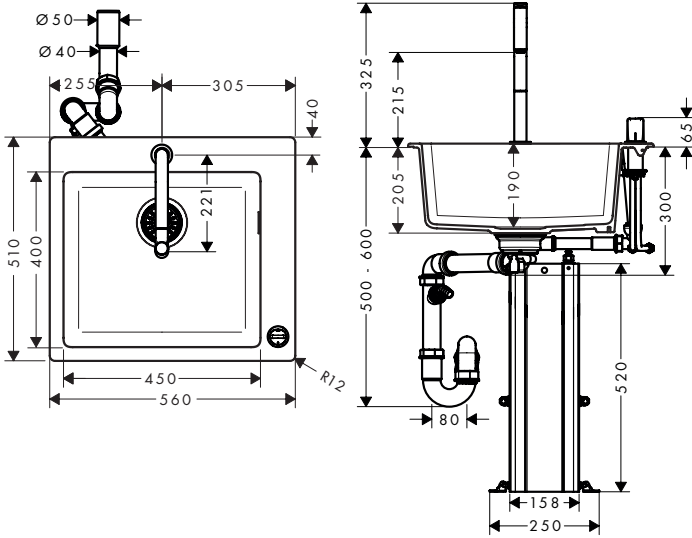



C51-F660-07 43218XXX

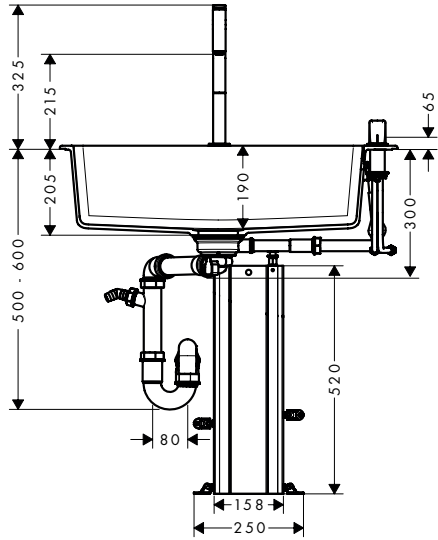
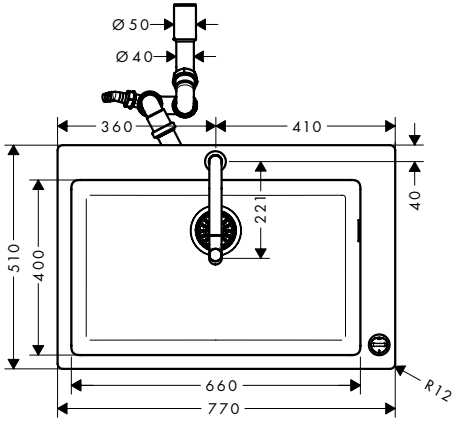

C51-F450-12 43228XXX

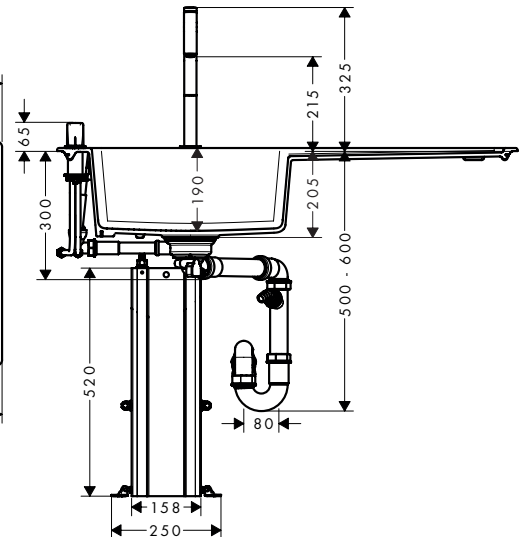
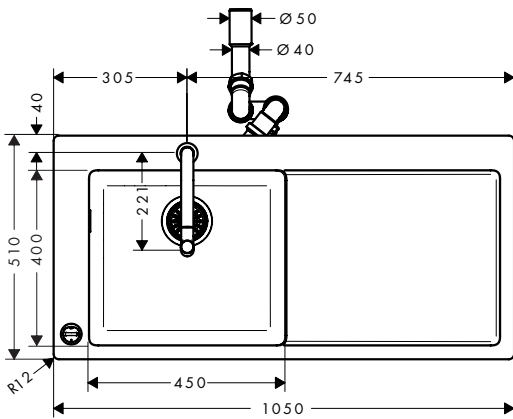

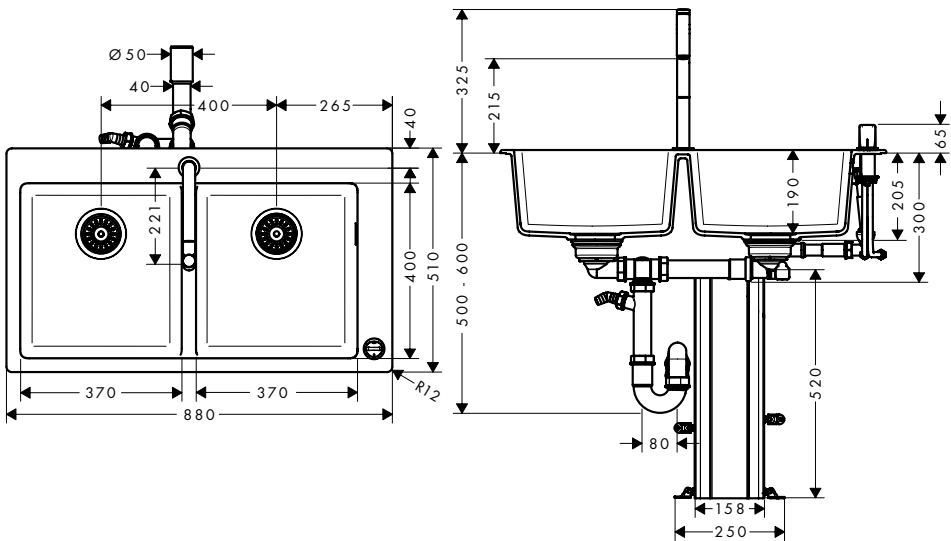
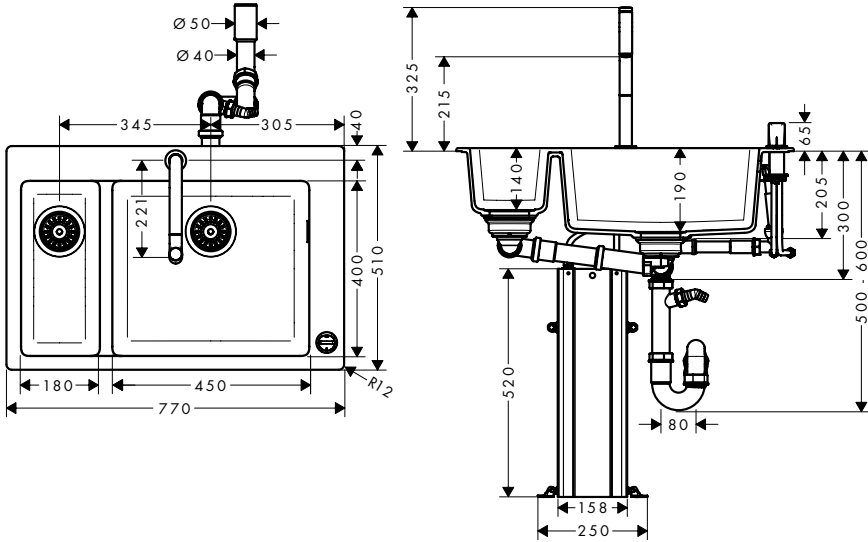



S510-F450 43312XXX / 43318XXX / 43322XXX / 43323XXX

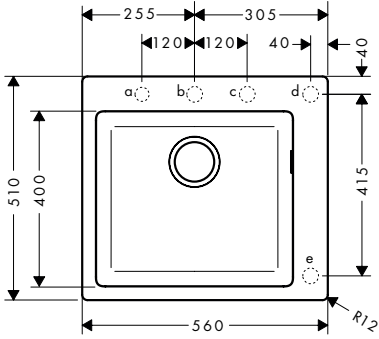

a, b, c, d, e = \varnothing 35

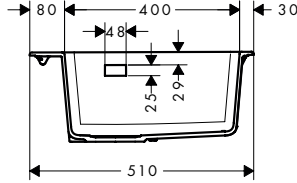
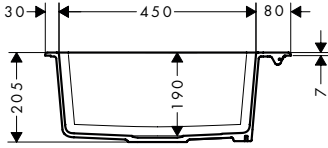

S510-F660 43313XXX / 43319XXX / 43324XXX / 43325XXX

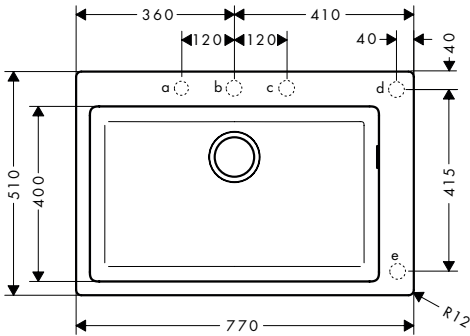

a, b, c, d, e = \varnothing 35

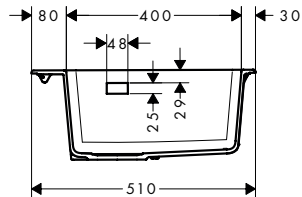
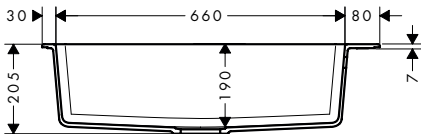

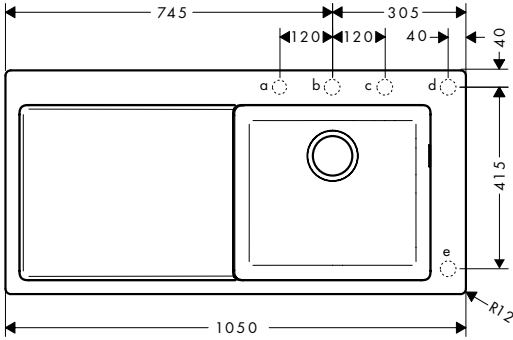

a, b, c, d, e = \varnothing 35

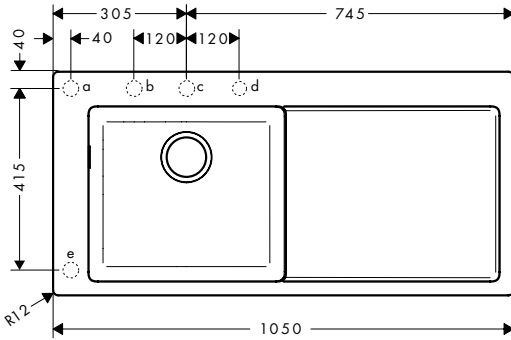
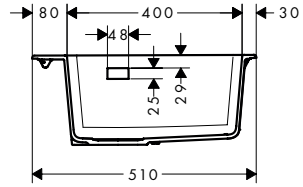
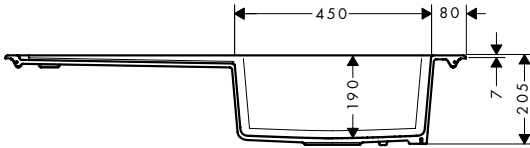

a, b, c, d, e = \varnothing 35

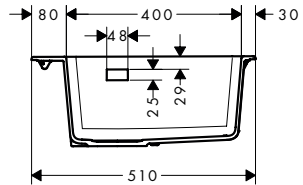
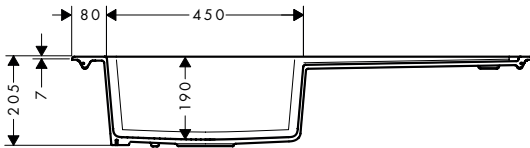



S510-F770 43316XXX / 43321XXX / 43328XXX / 43329XXX

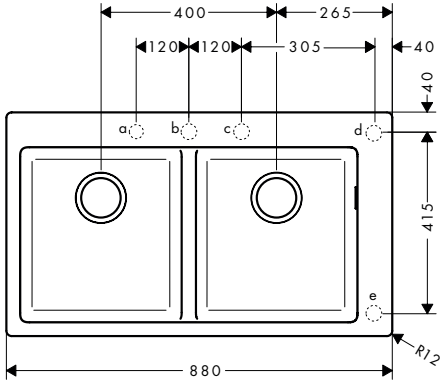

a, b, c, d, e = \varnothing 35

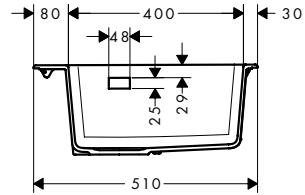
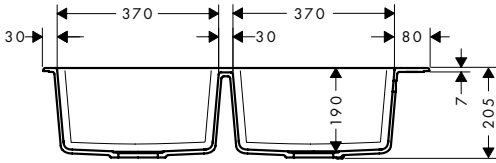

S510-F635 43315XXX

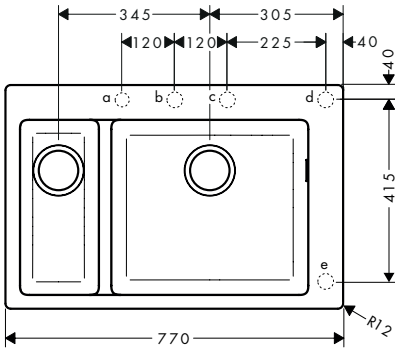

a, b, c, d, e = \varnothing 35

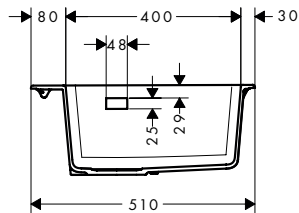
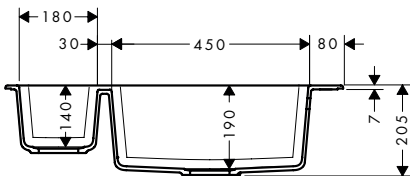

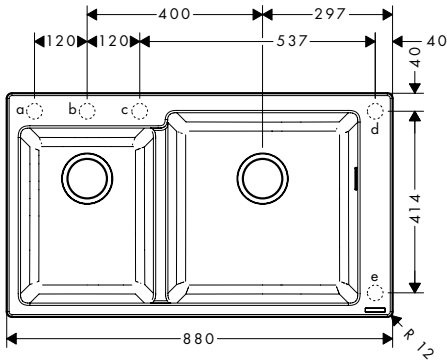

a, b, c, d, e = \varnothing 35

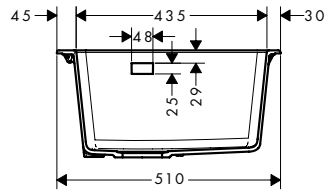
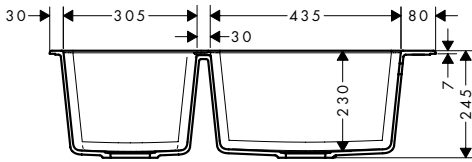

S520-F345 43356XXX

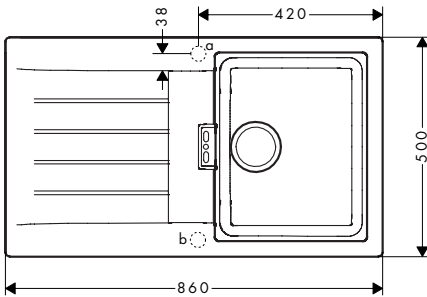

a, b = \varnothing 35

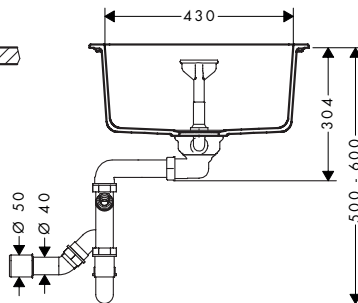
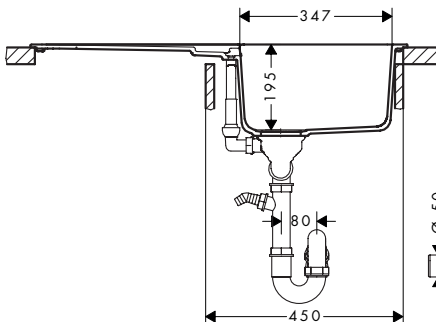

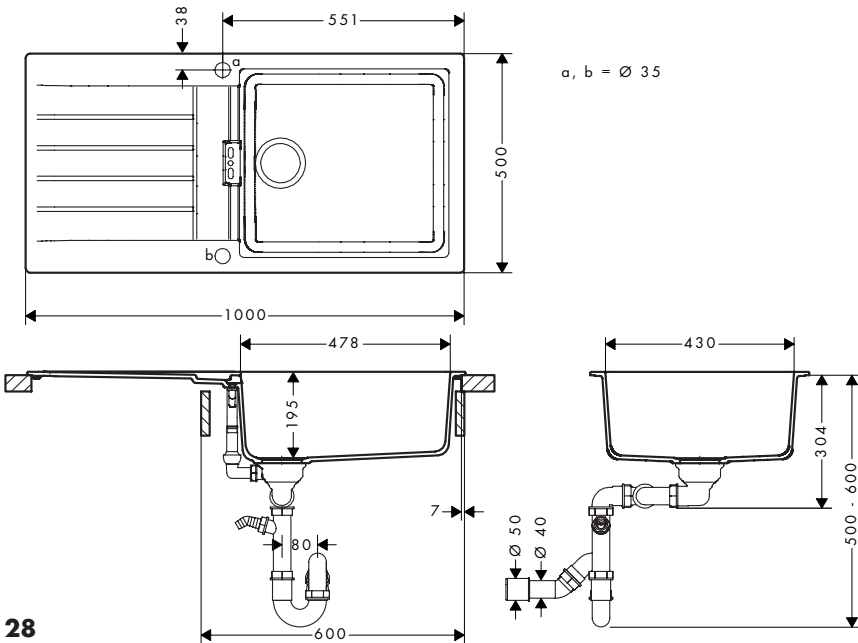
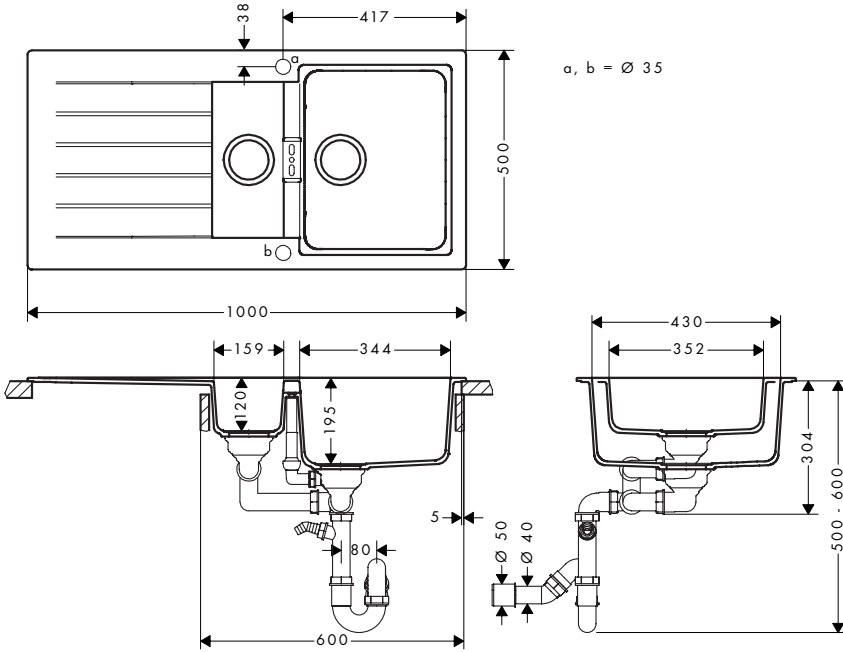

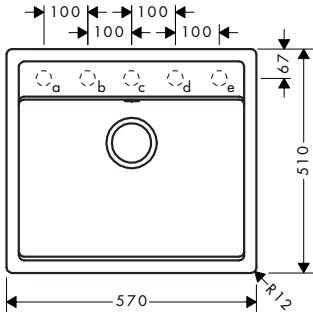

a, b, c, d, e = \varnothing 35

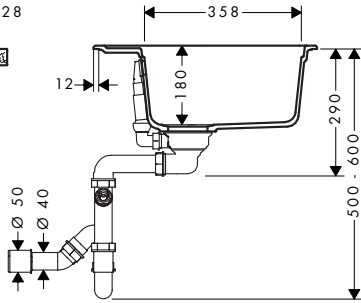
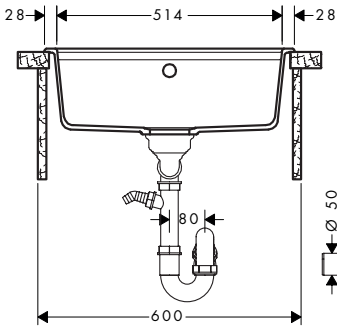



S510-U450 43431XXX / 43437XXX / 43441XXX / 43442XXX

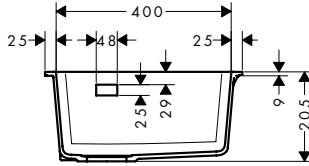
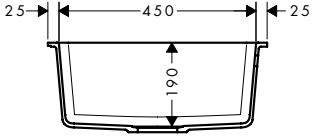
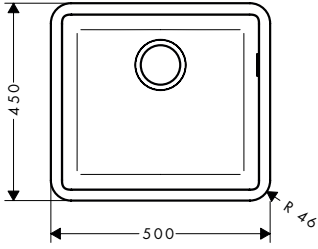

S510-U660 43432XXX / 43438XXX / 43443XXX / 43444XXX / 43451XXX

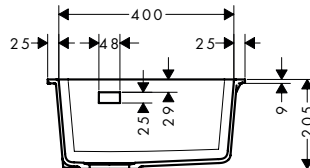
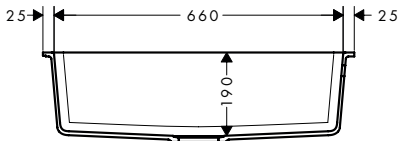
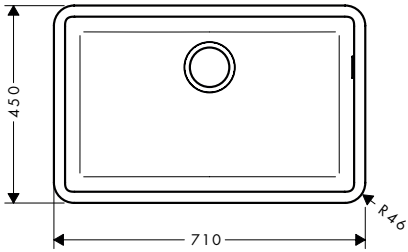

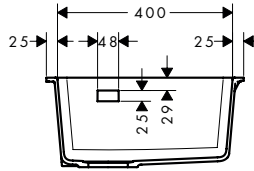
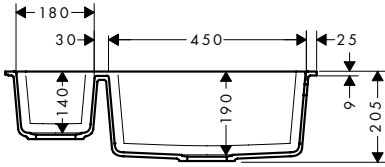
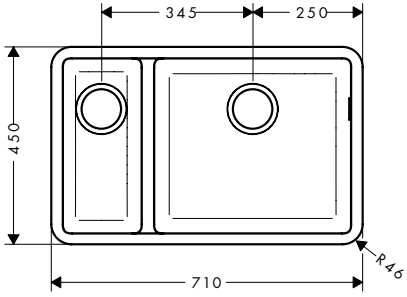

S510-U770 43434XXX / 43440XXX / 43447XXX / 43448XXX / 43456XXX

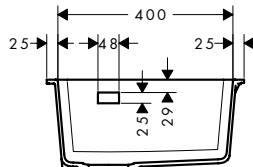
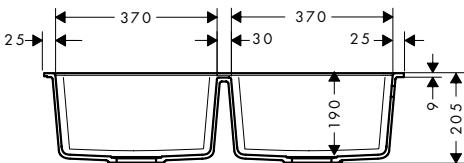
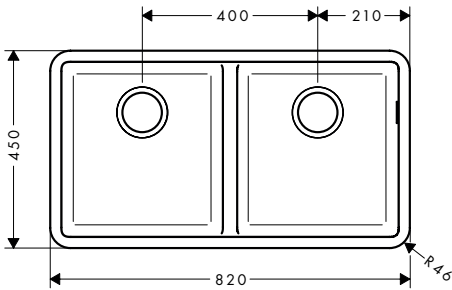

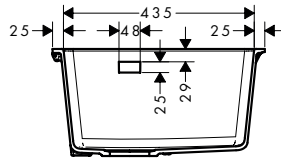
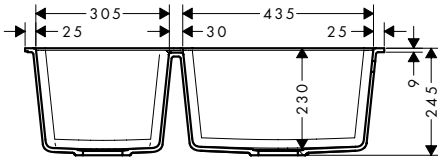
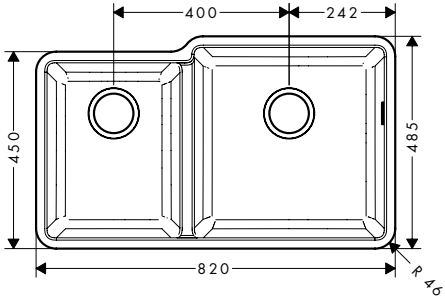

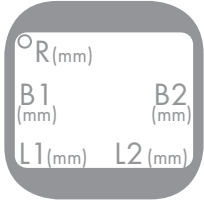
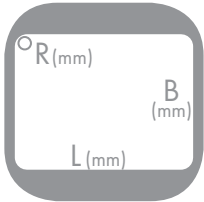
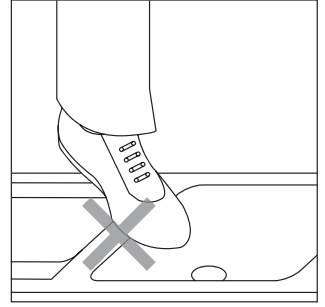
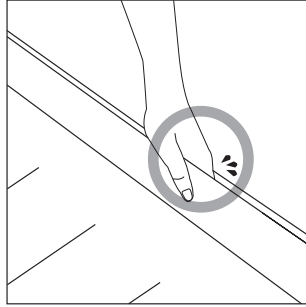
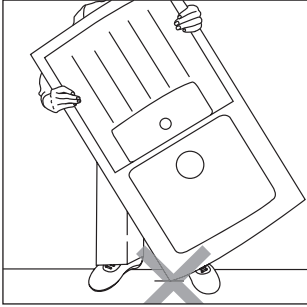

		L	B	R
43431XXX/43437XXX 43441XXX/43442XXX		448	398	16
43432XXX/43438XXX 43443XXX/43444XXX 43451XXX		658	398	16
43433XXX		658	398	16
43434XXX/43440XXX 43447XXX/43448XXX 43456XXX		768	398	16
		L1/L2	B1/B2	R
43436XXX/43439XXX 43445XXX/43446XXX		335/433	398/433	16

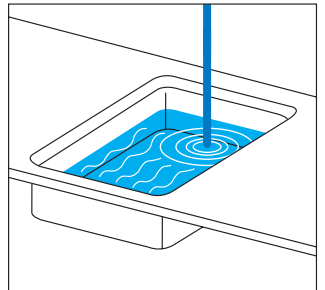
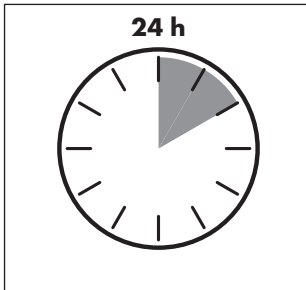
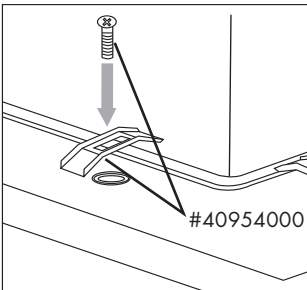
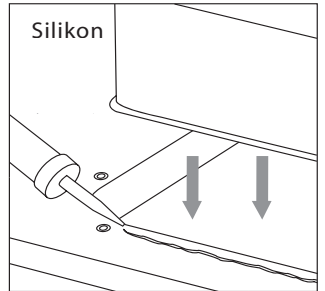
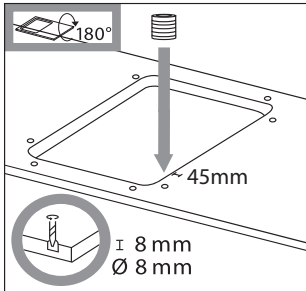
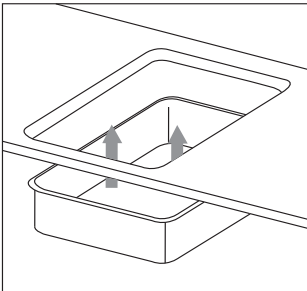

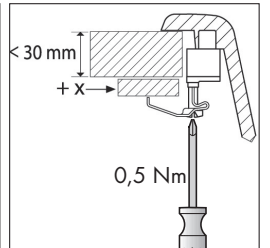
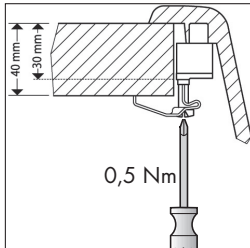
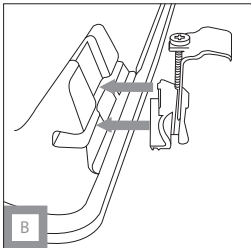
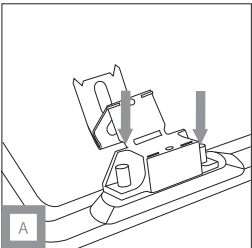
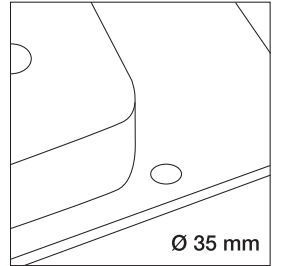
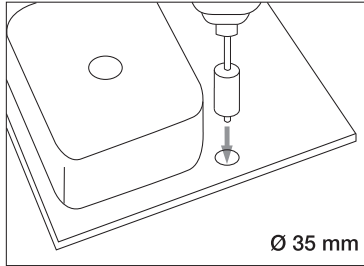
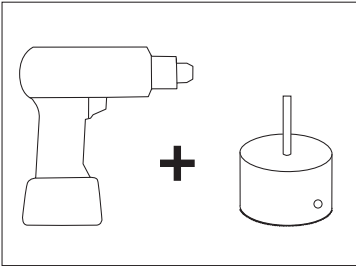
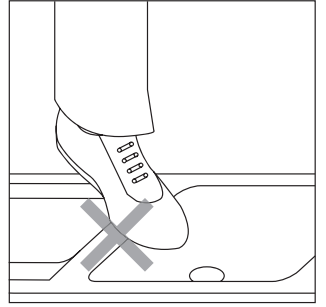
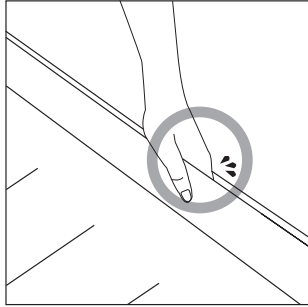
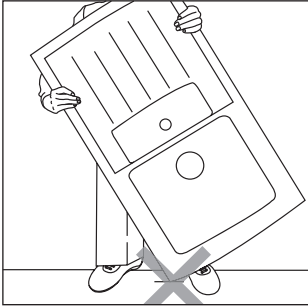

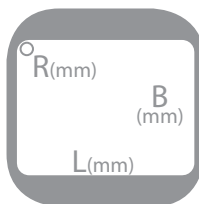
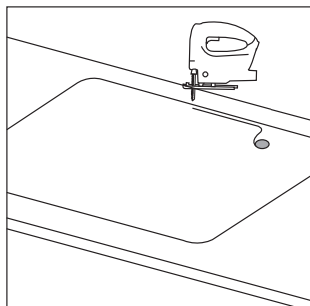

		L	B	R
43212XXX/43217XXX 43312XXX/43318XXX 43322XXX/43323XXX		540	490	10
43213XXX/43218XXX 43313XXX/43319XXX 43324XXX/43325XXX		750	490	10
43214XXX 43219XXX 43314XXX		1030	490	10
43227XXX 43228XXX 43330XXX		1030	490	10
43215XXX 43220XXX 43315XXX		750	490	10
43216XXX/43221XXX 43316XXX/43321XXX 43328XXX/43329XXX 43317XXX/43320XXX 43326XXX/43327XXX		860	490	10
43356XXX		840	480	10
43357XXX 43358XXX		980	480	10
43359XXX		552	490	10

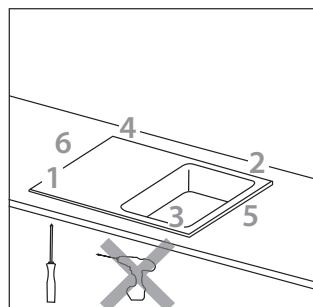
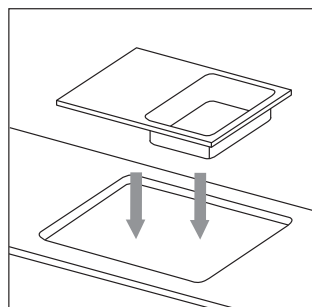
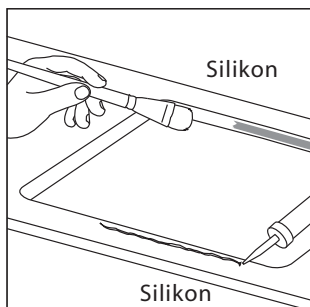



- DE** **Reinigung und Pflege von Quarzkompositspülen**
Kein/e Scheuermilch, Scheuermilch, konzentrierte Natronlauge, Ameisensäure, nichts stark Ätzendes.
- FR** **Nettoyage et entretien des éviers de la composition de quartz**
Pas de crème ni de poudre à récurer, pas de soude concentrée, pas d'acide formique, pas de produit fortement corrosif.
- EN** **Cleaning and caring for quartz composite sink**
Do not use abrasive cleaning creams or powders, concentrated caustic soda, formic acid or anything highly corrosive.
- IT** **Pulizia e cura dei lavelli di composito al quarzo**
Non utilizzare polvere abrasiva, liquidi abrasivi, soda caustica concentrata, acido formico, prodotti fortemente corrosivi.
- ES** **Limpieza y cuidado de fregaderos de compuesto de cuarzo**
No utilizar, leche o polvo de fregado, sosa cáustica concentrada, ácido fórmico, agentes muy corrosivos.
- NL** **Het schoonmaken en onderhouden van samengestelde gootsteen van het kwarts speelbakken**
Gebruik nooit schuurpoeder, vloeibaar schuurmiddel, geconcentreerde natronloog, mierenzuur of enig ander bijtend middel.
- DK** **Rengøring og pleje af kvarts komposit vask**
Brug ikke skurepulver, skuremælk, koncentreret natronlud, myresyre, og ikke midler, der er stærkt ætsende.
- PT** **Limpeza e manutenção de lava-louças pia composta de quartzo**
Não usar cremes ou pós abrasivos, lixívia de soda concentrada, ácido fórmico, nada que seja cáustico.
- PL** **Czyszczenie i pielęgnacja zlewozmywaków kompozytowy kwarcowy**
Do pielęgnacji nie stosować proszku oraz mlecza do szorowania, skoncentrowanych środków na bazie sody (ługów sodowych), kwasu mrówkowego, środków mocno żrących.
- CS** **Čištění a údržba granitových dřezů**
Žádný hrubší prášek, tekutý písek, hydroxid sodný, kyselina mravenčí, louh.
- SK** **Čistenie a starostlivosť o křemenný kompozitní drezy**
Nepoužívajte prášok/prášky na drhnutie, tekutý čistič na drhnutie, koncentrovaný lúh sodný, kyselinu mravčiu, nič silno žieravé.
- ZH** **石英水槽的清洁和保养**
不使用研磨膏，研磨粉，浓缩的氢氧化钠溶液，甲酸，以及会产生强烈腐蚀的物质。
- RU** **Уход за кварцевая композитная раковина**
Не пользуйтесь абразивными чистящими средствами и порошками, концентрированным натриевым щелочом, муравьиной кислотой, едкими чистящими средствами.
- FI** **Kvartsikomposiittiallas puhdistus ja hoito**
Älä käytä hankausjauhetta, hankausnestettä, väkevää natriumhydroksidiliuosta, muurahaishappoa, erittäin syövyttäviä aineita.
- SV** **Rengöring och skötsel av kvarts komposit diskbänk**
Använd ej flytande skurmedel, skurpulver, koncentrerad soda, myrsyra eller starkt frätande medel.
- LT** **Kvarco kompozicinė kriauklė valymas ir priežiūra**
Nenaudokite šveičiamųjų miltelių, šveičiamojo pienelio, koncentruoto šarmo, skrudžių rūgšties, stipriai esdinančių priemonių.

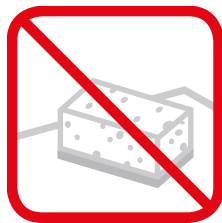

**HR Čišćenje i održavanje kvarcni kompozitni sudoper**

Ne smiju se koristiti praškasta ili tekuća abrazivna čistila, koncentrirana natrijeva lužina, mravlja kiselina kao ni druga jako nagrizajuća sredstva.

RO Curățarea și îngrijirea chiuvetelor din compozită cu cuarț

Nu utilizați prafuri abrazive, lapte pentru degresare, hidroxid de sodiu concentrat, acid formic și soluții foarte corozive.

EL Καθαρισμός και φροντίδα σύνθετος νεροχύτες χαλαζία

Μη χρησιμοποιείτε σκόνες καθαρισμού, γαλακτώματα, συμπυκνωμένο διάλυμα καυστικής σόδας, μυρμηκικό οξύ, ιδιαίτερα διαβρωτικά υλικά.

SL Čiščenje in nega quartz kompozit umivalnik

Ne uporabljajte abrazivnih praškov, tekočin, koncentriranega natrijevega luga, mravljične kisline in nobenih močno jedkih sredstev.

ET Kvartskomposiitvalamu puhastus ja hooldus

Ilma abrasiivse pulbri, abrasiivse piima, kontsentreeritud kaustilise sooda, sipelghappe, tugevalt happelise aineta.

LV Kvarca kompozitmateriālu izlietne tīrīšana un kopšana

Nelietojiet abrazīvus tīrīšanas krēmus vai pulverus, koncentrētu kaustisko soda, skudrskābi vai neko citu, kas ir ļoti kodīgs.

SR Čišćenje i održavanje kvarcni kompozitni lavabo

Zabranjena je upotreba praškastih ili tečnih abrazivnih sredstava za ribanje, koncentrisanog rastvora kaustične sode, mravlje kiseline i drugih jako nagrizajućih sredstava.

NO Rengjøring og stell av kvarts kompositt vasker

Ikke bruk skurepulver, skuremiddel, konsetrert natronlut, maursyre eller andre sterkt etsende stoffer.

BG Почистване и поддръжка на кварцов композитен умивалник

Не използвайте абразивни препарати под формата на прах и мляко, концентрирана сода каустик, мравчена киселина, нищо силно разяждащо.

JP クォーツ複合シンクのクリーニングとお手入れ方法

磨き粉や研磨剤(クレンザー)、および苛性ソーダ(水酸化ナトリウム)、ギ酸、強力な酸性類の洗剤は使用できません。

SQ Pastrimi dhe perkujesesi për lavaman i përbërë nga kuarsi

Pa pluhur pastrimi, krem pastrimi, solucion të koncentruar të hidroksidit të natriumit, acid formik, kaustik të fortë.

AR تنظيف وصيانة سينك كامبوزيت كوارتز
لا يجب إستعمل كربيمات أو مساحيق التنظيف الكاشطة، الصودا الكاوية شديدة التركيز، حمض الفورميك أو أي مادة أكالة.

TR Kvarers kompozit lavabo temizliđi ve bakımı

Temizleme tozu, ovma kimyasalı, konsantrre yakıcı soda, formik asit, aşırı tahriş edici madde kullanılmamalıdır.

HU Kvarc kompozit mosogatók tisztítása és ápolása

Ne használjon súrolóport, folyékony súrolószereket, koncentrált nátrónlúgot, hangyasavat, és bármilyen maró hatású szert.

HE ניקוי וטיפול בכיור מקוורץ מרכב

אסור להשתמש בקרמים או אבקות ניקוי אברזיביים, סודה קאוסטית מרוכזת, חומצה פורמית או חומר קורוזיבי אחר





Balsam (Steinversiegler für nicht saugende Untergründe, lebensmittelrechtliche Seite immer beachten!)

Baume (produit de scellement de pierre pour support non absorbant, toujours faire attention au côté alimentaire conforme !)

Balsam (Stone-protector for non-absorbent substrates, pay attention to the food legislation!)

Balsamo (sigillante per pietre per superfici non assorbenti, considerare sempre il lato legale inerente i generi alimentari!)

Bálsamo (sellado para superficies no absorbentes, observar la seguridad alimentaria!)

Balsem (tegelafdichting voor niet-absorberende ondergronden, neem altijd de levensmiddelwetgeving in acht!)

Balsam (stenforsegler til ikke-sugende undergrunde, følg altid den levnedsmiddelretlige side!)

Bálsamo (selante para materiais não absorventes, prestar sempre atenção à legislação em vigor relativa aos produtos alimentares!)

Balsam (lak do kamieni na nie wciągające podłoża, Zawsze wziąć pod uwagę stronę dotyczącą norm związanych z żywnością!)

Balsam (Impregnace kamene pro nesavé podklady, vždy respektuje informace na stránce o potravinách!)

Balzam (konzervačný prostriedok na kameň pre nesavé podklady, vždy prihliadajte na stranu určenú pre potraviny!)

清清香脂 (非吸收性石材保护剂: 注意食品安全法规)

Бальзам (герметизирующий состав для невпитывающих каменных поверхностей, всегда соблюдайте требования для пищевых продуктов!)

Hoitoaine (kivisuoja ei-imeville alustoille, huomioi aina elintarvikelainisäädäntö!)

Balsam (förseglingsmedel för sten för ej sugande underlag, beakta alltid livsmedelsrättslig sida!)

Balzāms (hermetizējošs sastāvs neabsorbējošām akmens virsmām, lūdzu, vienmēr ievērojiet prasības pārtikas produktiem!)

Balzam (za impregnaciju neupijajućih kamenih podloga, pridržavajte se propisa o rukovanju predmetima koji dolaze u dodir s hranom!)

Balsam (soluție de impermeabilizare pentru suprafețe neabsorbante, respectați pagina cu prevederile legislative privind produsele alimentare!)

Βάλσαμο (Προϊόν σφράγισης για μη απορροφητικές επιφάνειες, προσέχετε πάντα τα σχετικά άρθρα της νομοθεσίας τροφίμων!)

Balzam (premaz za kamen za nevojne podloge, vedno upoštevajte živilsko zakonodajo!)

Palsam (kivi vuugitāide mitteimavate aluspindade jaoks, jälgige alati toiduinetege kokkusobivaid külg!)

Balsam (Stone-protector for non-absorbent substrates, pay attention to the food legislation!)

Balzam (za impregnaciju neupijajućih kamenih podloga, pridržavajte se propisa o rukovanju predmetima koji dolaze u dodir s hranom!)

Balsam (Steinforsegling for ikke-sugende underlag, følg alltid næringsmiddelforskriftene)

Балсам (препарат за запечатване на камък за не попиващи основи, вземете под внимание страницата отнасяща се към законодателството за хранителни продукти!)

表面保護材 (非浸透性の石材用保護剤, 食品衛生法に適合するものをご使用ください。)

Balsam (lustues guri për sipërfaqe jo absorbuese, vini re gjithmonë udhëzimet e ushqimeve بلسم (حامي للحجر و مانع لامتصاص المواد, يجب مراعات التشريعات الغذائية!)

Krem (emici özelliği olmayan zeminler için taş dolgu, gıda maddesi yasasına uygun olan tarafta daima dikkate alın!)

Balzsam (köimpregnáló nem nedvszívó felületekre, mindig vegye figyelembe az ételkészítési vonatkozásait!)

Balsam (מגן אבן למצעים לא סופגים, צריך לשים לב לתקנות המזון!)



Entkalker
Détartrant
Limescale Remover
decalcificatore
descalcificador
Ontkalker
Afkalker
Descalcificante
Odkamieniacz
Přípravek na odstranění vodního kamene
Odvárňovač
除垢剂
Средство для удаления извести
Kalkinpoistoaine
Avkalkare

Kalkiy valiklis
Sredstvo za uklanjanje kamenca
Decalcifiant
Προϊόν αφαίρεσης αλάτων
Sredstvo za odstranjevanje arnenca
Katlakivieemaldi
Limescale Remover
Sredstvo za uklanjanje kamenca
Kalkfjerningsmiddel
Препарат за почистване на варовик
カルキ除去剤
Detergjent ani calcar

مزيل للرواسب

מסיר אבנית

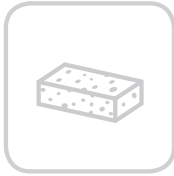

Radierschwamm
éponge gomme
Eraser sponge
spugna raschietto
esponja para borrar la suciedad
Sponsje
Svamp til fjernelse af snavs
Espanja de limpeza
Gąbka czyszcząca
houbka na odstraňování nečistot
Čistiaca „gumovacia“ hubka
去污海绵
Губка для зачистки
Puhdistussieni
Radersvamp
Šveičiamoji kempinė

Abrazivna spužva
Burete magic
Σπόγγος για σβήσιμο
Radirna gobica
Pesulahjendi
Eraser sponge
Abrazivni sunder
Viskelærsvamp
Гъба за изтриване
メラミンスポンジ (大きな傷の補修に使用します。
細かい傷がつきます)
Sfungjer për pastrim të thellë

إسفنجة المسح

Kauçuk sünger
Súrolószivacs

ספוג

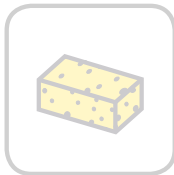

Spülschwamm
Éponge à rincer
Dishwashing sponge
Spugna per il lavaggio
Espanja
Afwasspons
Rengøringsvamp
Espanja
Gąbka
Mycí houbka
Hubka na riad
清洁海绵
Моющая губка
Pesusieni
Disksvamp

Plovimo kempinė
Spužva za pranje posuđa
Burete de spălare
Σφουγγάρι πιάτων
Pomivalna gobica
Pesukäsni
Dishwashing sponge
Sunder za pranje posuđa
Vaskesvamp
Гъба за миене
食器洗い用スポンジ
Sfungjer

اسفنجة غسل الأواني

Bulaşık süngeri
Mosogatószivacs

ספוג לניקוי כלים



Einfaches Putztuch
Chiffon ordinaire
Ordinary cleaning cloth
Straccio semplice
Paño limpiador simple
Gewoon reinigungsdoekje
Enkel rengøringsklud
Pano de limpeza simples
Miękka ściereczka
Čistící hadřík
Obyčajná utierka
简单的抹布
Тряпка для мытья
Tavallinen siivousliina
Vanlig rengöringsduk

Paprasta šluostė
Obična krpa za brisanje
Cârpă de curățare simplă
Απλό πανί καθαρισμού
Preprosta krpa za čiščenje
Lihtne pesulapp
Ordinary cleaning cloth
Obična krpa za brisanje
Enkel vaskeklut
Обикновена кърпа за почистване
クリーニング用のクロス
Leckė e thjeshtë pastrimi

تنظيف عادي للأقمشة

Tek katli temizleme bezi
Egyszerű törlőkendő

מטלית ניקוי רגילה



Geschirrspülmittel
Liquide à vaisselle
Washing-up liquid
Detersivo per stoviglie
Detergente lavavajillas
Afwasmiddel
Opvaskemiddel
Detergente para a louça
Środek do zmywania naczyń
Přípravek na umývání nádobí
Čistiaci prostriedok na riad
洗洁精
Моющее средство для посуды
Astianpesuaine
Diskmedel

Indų ploviklis
Sredstvo za pranje posuđa
Solujie de spălat vase
Υγρό πιάτων
Pomivalno sredstvo
Pesuvahend
Washing-up liquid
Sredstvo za pranje posuđa
Oppvaskemiddel
Препарат за измиване на съдове
台所用中性洗剂
Detergjent për enët

سائل الغسيل

Bulaşık deterjanı
Mosogatószer

נוזל שטיפה



Spülmaschinenpulver
Poudre à lave-vaisselle
Dishwasher powder
Detersivo per lavastoviglie
Detergente en polvo para lavavajillas
Vaatwaspoeder
Opvaskemaskinpulver
Pó para máquina de lavar louça
Proszek do zmywarek
Prášek do myčky na nádobí
Prášok do umývačky riadu
洗碗机专用洗洁粉
Порошок для посудомоечной машины
Konetiskijauhe
Diskmaskinpulver

Milteliai indaplovei
Praşak za strojno pranje posuđa
Praf pentru maşina de spălat vase
Σκόνη πλυντηρίου πιάτων
Prašek za pomivalne stroje
Pesupulber
Dishwasher powder
Praşak za mašinsko pranje posuđa
Oppvaskemaskinpulver
Прах за миялни машини
食洗機用粉せっけん
Detergjent për pjatatarësen

مسحوق غسالة الأواني

Bulaşık makinesi tozu
Mosogatógép mosogatópor

אבקה למדיח כליים

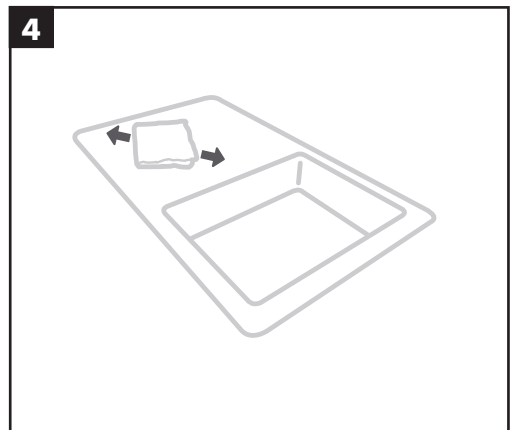
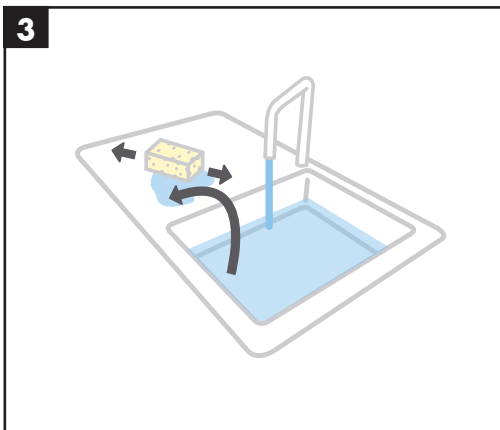
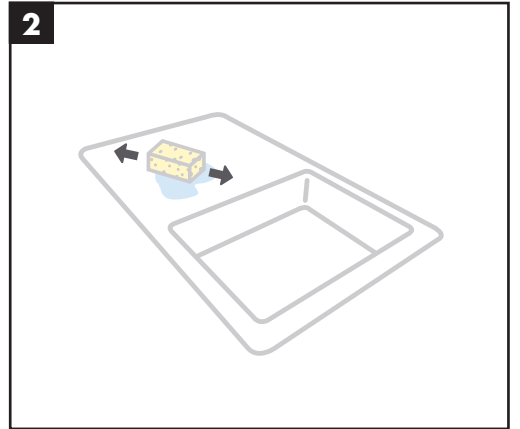
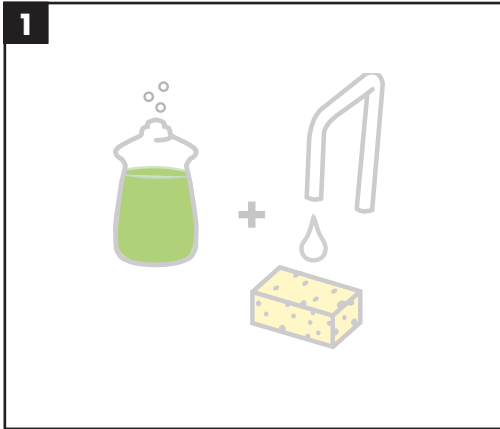

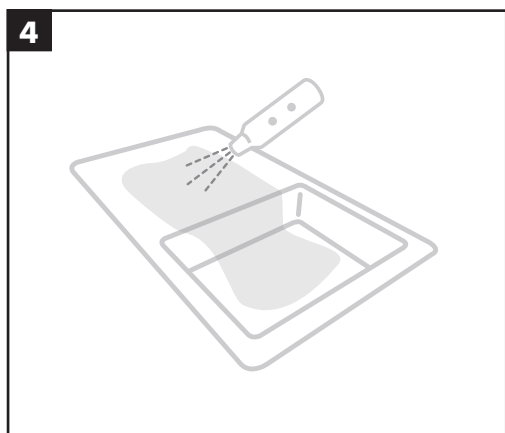
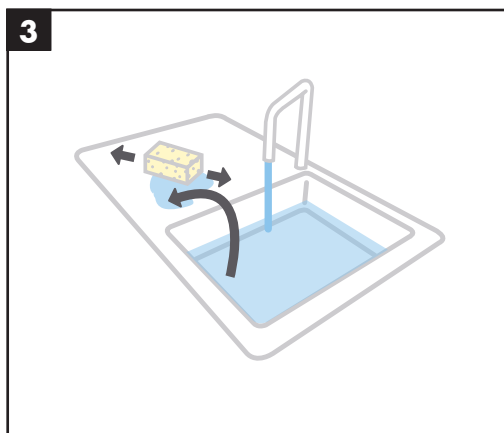
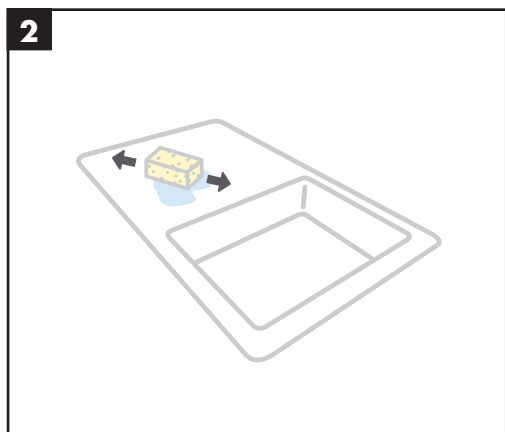
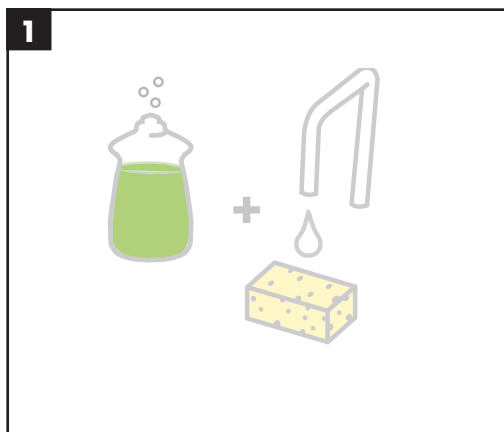



5



00:10:00

6

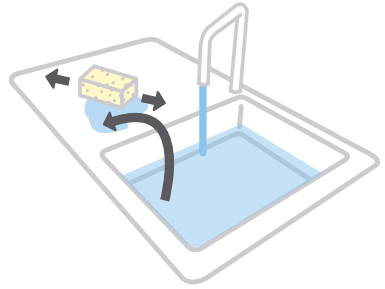

7

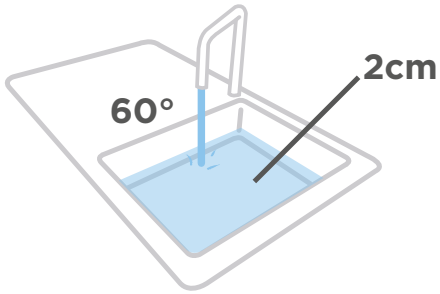

8



9



01:30:00

10

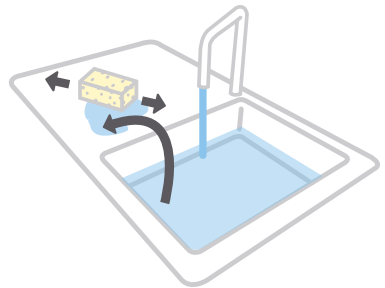

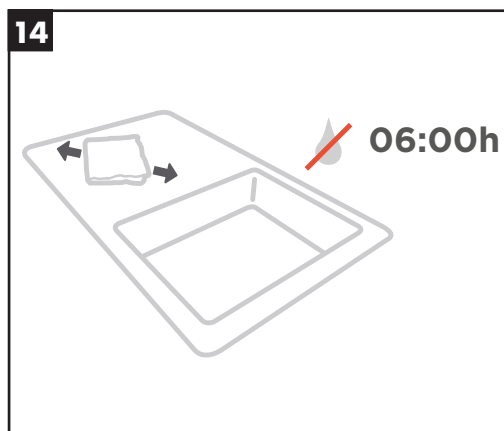
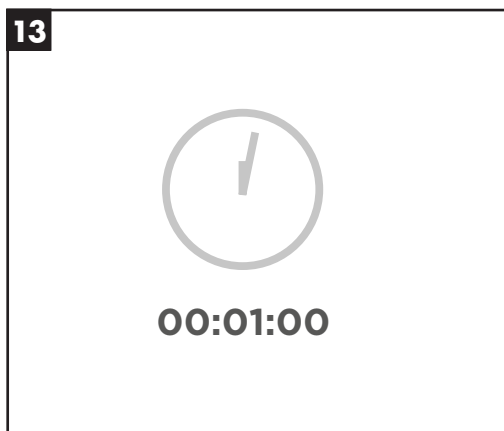
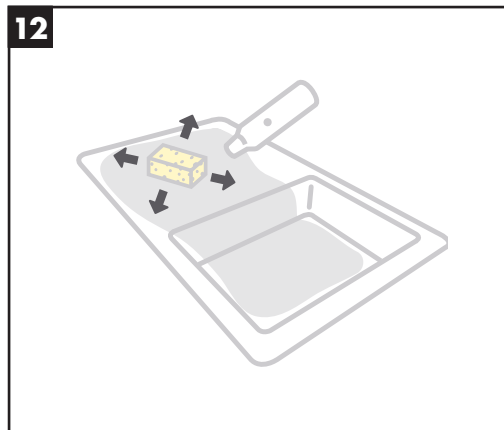
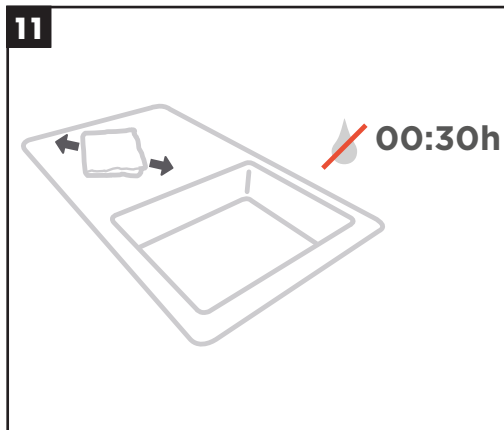

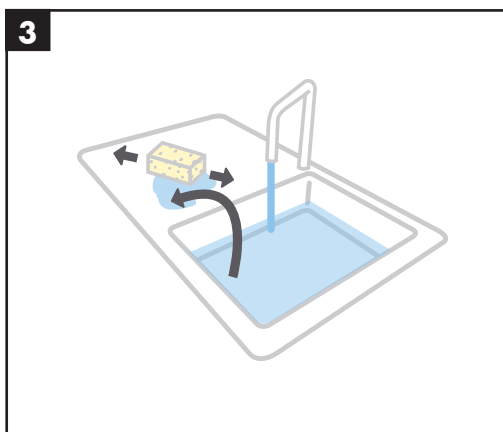
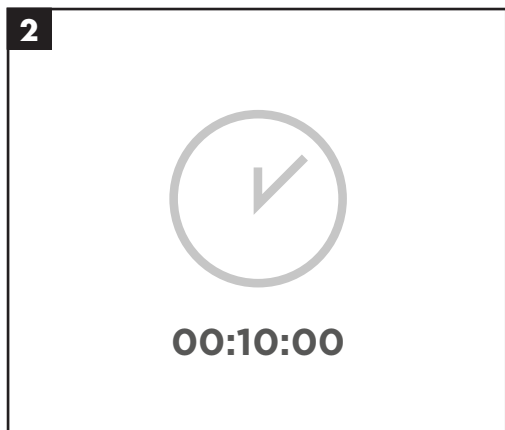
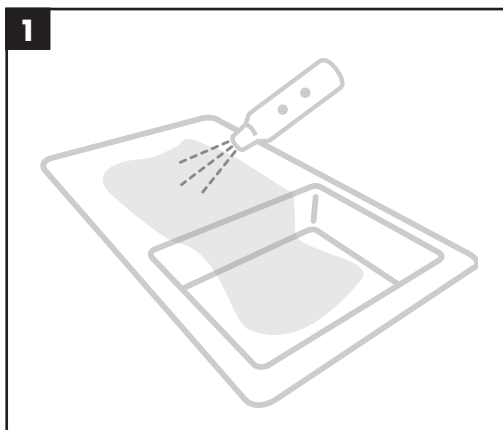

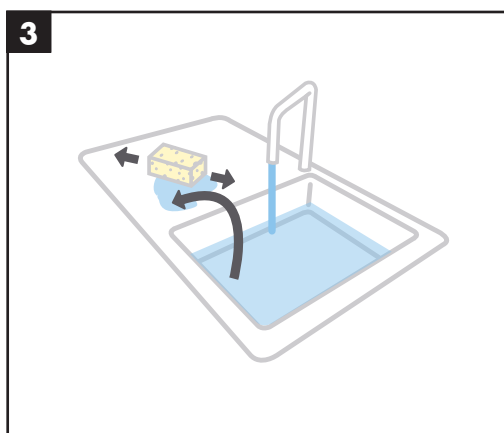
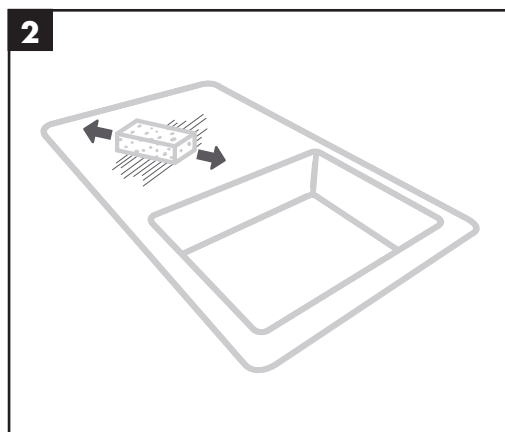
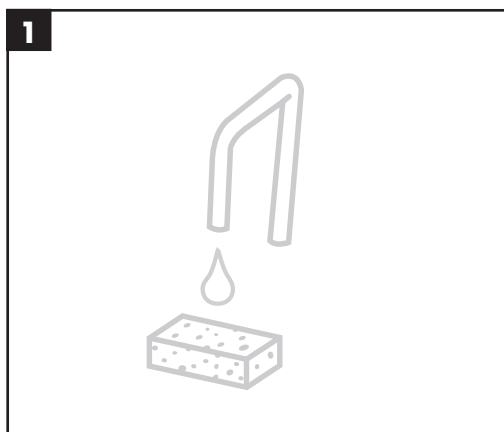



hansgrohe

Hansgrohe · Auestraße 5 · 9 · D-77761 Schiltach · Telefon +49 (0) 78 36/51-1282 · Telefax +49 (0) 7836/511440
E-Mail: info@hansgrohe.com · Internet: www.hansgrohe.com

07/2022
9.062.65.04