



1036-251

STANDARD DESIGN FEATURES

Length: 96 in./243 cm.
Height: 15.25 in./31 cm. (Lowest)
Height: 56.25 in./143 cm. (Highest)
Width: 48 in./122 cm.

- The mobile necropsy table features all heavy-gauge stainless steel construction
- The unit is designed to handle a centralized load up to 3,000 lbs./1361 kg.
- The inner frame support is fabricated from heavy gauge steel tubing
- The table top and inner frame support are attached to an electrically-powered hydraulic scissor lift. The lift has a capacity up to 3,000 lbs./1361 kg. (~115v / 60 Hz / 1 Ph - 1 HP motor)
- A drain opening located on the back edge of the table.
- Functions on (4) lock pivot casters that allows the table to tilt as desired
- Easy-to-use up/down elevation control
- Retractable electrical cord reel
- Tabletop can be sized to your specific project requirements
- Hydraulic cylinders outfitted to the scissor lift allowing the table top to lift to the height of up to 56.25 in/143 cm

MODEL 1036-251 MOBILE NECROPSY TABLE, TILT AND LIFT

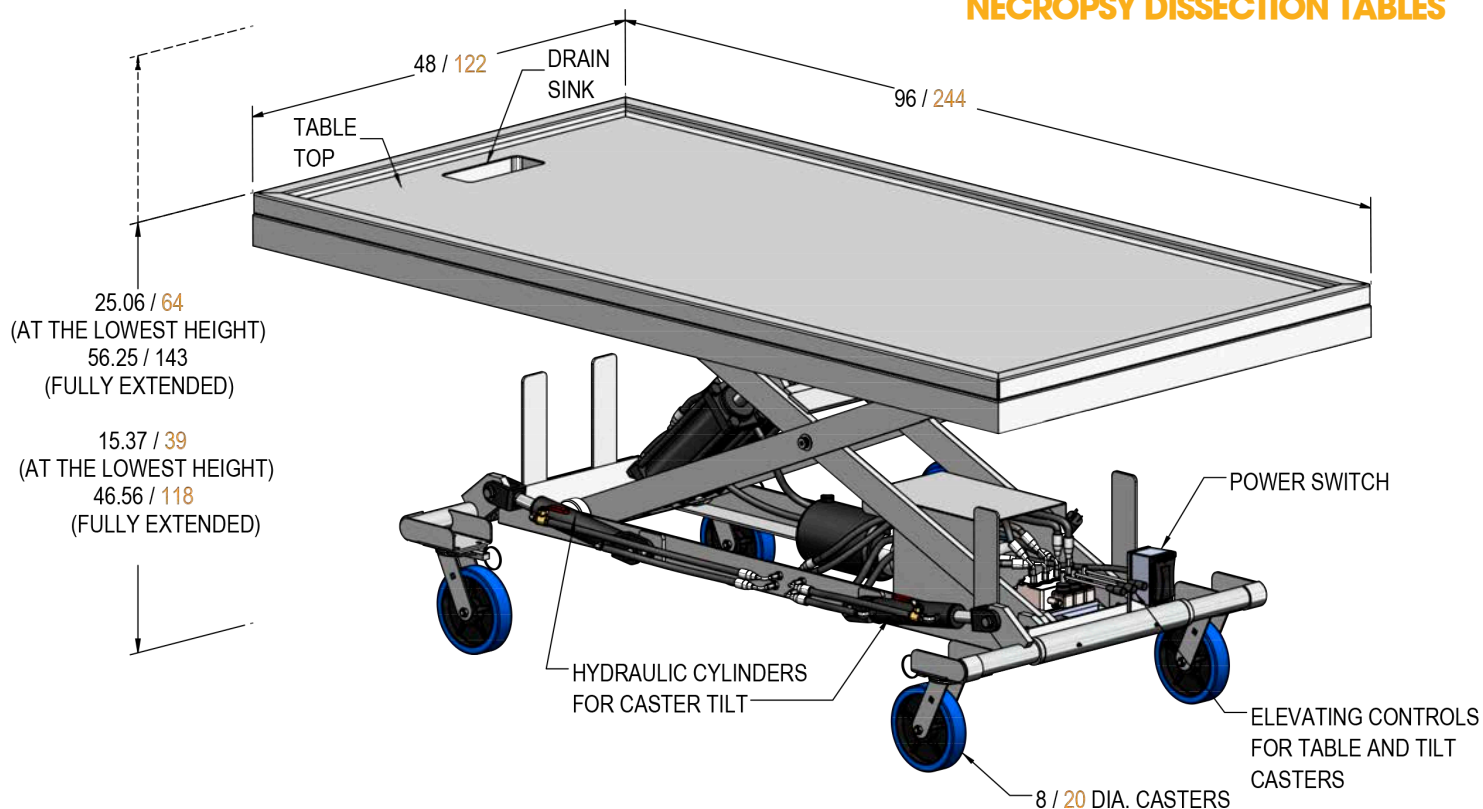

All measurements in inches/centimeters +-



DRAIN HOLE



HYDRAULIC CONTROLS



VARIABLE FRONT AND REAR WHEEL TILT

MODEL 1036-251 LAYOUT DRAWING & OPTIONAL FEATURES

T(800) 410-0100
T(626) 334-1471
F(626) 334-1704

411 North Aerojet Avenue
Azusa, CA 91702
www.mortechmfg.com

Optional Accessories

- Type 316 stainless steel (top only)
- Tilt Feature

Options based on available space

When planning an order, we will assist you in selecting options to complete your system. Please feel free to contact us.

See pages 9-17 to 9-19 for a full list of sink station accessories.

Custom layout and designs are available.