

# SINK STATIONS MODEL 600035 VENTILATED EMBALMING TABLE

## STANDARD DESIGN FEATURES

Width: ..... 32 in./81 cm.  
 Length: ..... 80 in./203 cm.  
 Height (Tray working): ..... 32 in./81 cm.  
 Height (Overall): ..... 38 in./97 cm.

The stainless steel embalming table is equipped with rollers and is designed as an integral part of the embalming process and cadaver handling. It accepts the standard stainless steel body trays (T3626). It is sloped for drainage and uses rollers that allow for easy loading and unloading of cadavers, which makes transferring to the 86-129 Roller Rack or any of the Mortuary Refrigerators very easy.

- A tray rinse for easy cleaning, sanitation and rapid disposal of waste materials
- Fabricated from 1.5 in./3 cm. square, .12 tubing thickness, 304 stainless steel tubing
- Stainless steel has a grained finish and all welds match adjoining surfaces
- (4) 8 in./20 cm. casters, all with brake mechanism
- Designed with a permanent slope of 3 in./5 cm.
- Standard design for 23 in./58 cm. body tray, please inquire for special order sizes
- Flip-latch to hold tray in position while in transport
- Easy quick connections for electrical and water rinse assembly
- GFCI duplex receptacle w/ waterproof cover
- (2) Flip tray rinse assemblies
- (2) side perforated exhaust downdraft ventilation connections (connect to the 1036-25 Ventilated Embalming Station)

All measurements in inches/centimeters +-

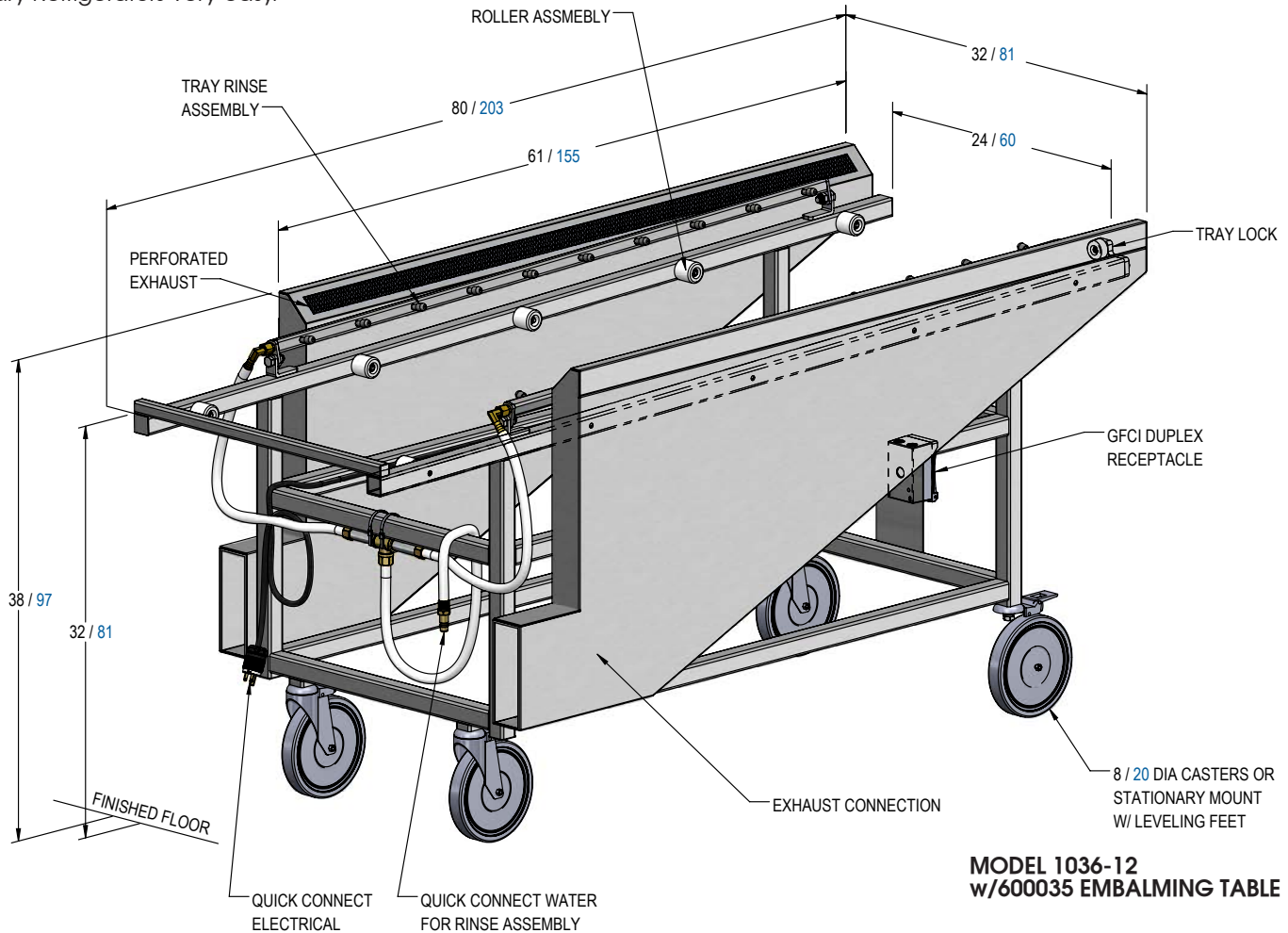

**MODEL 1036-12  
w/600035 EMBALMING TABLE**



## SINK STATIONS

MODEL 1036-25-C Center

MODEL 1036-25-L Left

MODEL 1036-25-R Right

MODEL 1036-25-D Double



## MODEL 1036-25 CENTER, LEFT, RIGHT, DOUBLE VENTILATED EMBALMING STATION

### STANDARD DESIGN FEATURES

Model 1036-25-C Sink Center  
Model 1036-25-L Sink Left  
Model 1036-25-R Sink Right  
Model 1036-25-D Double Sink

- All stainless steel construction with heliarc-welded seams and joints, ground and polished to a smooth finish
- Vent system for connection to embalming tables
- Exhaust duct for connection to building ventilation system for exterior connection at top of station
- Quick-connect plumbing and electrical for connection to embalming table
- Full length specimen shelf (12 in./30 cm. wide x "length of the unit")
- Large radius on all inside corners for easy cleaning and required sanitation
- Large single-compartment sink with rapid and positive drainage
- Cart-to-sink locking mechanism with slide latch which can be accessed from either side of the carrier
- Large instrument drawer(s)
- Plumbing and electrical lines are factory-installed and require only minimum installation
- GFCI duplex receptacles w/ waterproof cover
- Heavy-duty commercial waste disposer, 1/2 hp and switch
- Light fixture(s) over the work area
- Deluxe aspirator with reverse flow for additional waste removal: "reverse flow" feature instantly relieves suction clogging by providing a reverse pressure of water
- Hot and cold water fixture(s) with convenient goose-neck faucet and wrist blade handles
- Spray hose assembly with cold water control valve, nozzle and 10 ft./3 m. of flexible hose
- Complete back-siphon protection provided by reduced pressure principle assembly

Plumbing fixtures can be located in various positions depending on your desired work environment

All measurements in inches/centimeters +-



# SINK STATIONS

## Model 1036-25-C Sink Center

Width: .....29 in./74 cm.  
 Length: .....114 in./289 cm.  
 Working Height:.....34 in./86 cm.

## Model 1036-25-L Sink Left

Width: .....29 in./74 cm.  
 Length: .....84 in./213 cm.  
 Working Height:.....34 in./86 cm.

## Model 1036-25-R Sink Right

Width: .....29 in./74 cm.  
 Length: .....84 in./213 cm.  
 Working Height:.....34 in./86 cm.

## Model 1036-25-D Double Sink

Width (Standard):.....29 in./74 cm.  
 Length: .....132 in./335 cm.  
 Working Height:.....34 in./86 cm.



**DOCKING VENTILATED 600035**



**UTILITY DRAWER**



## Optional Features & Accessories

See pages 3-13 to 3-17 for a full list of sink station accessories.

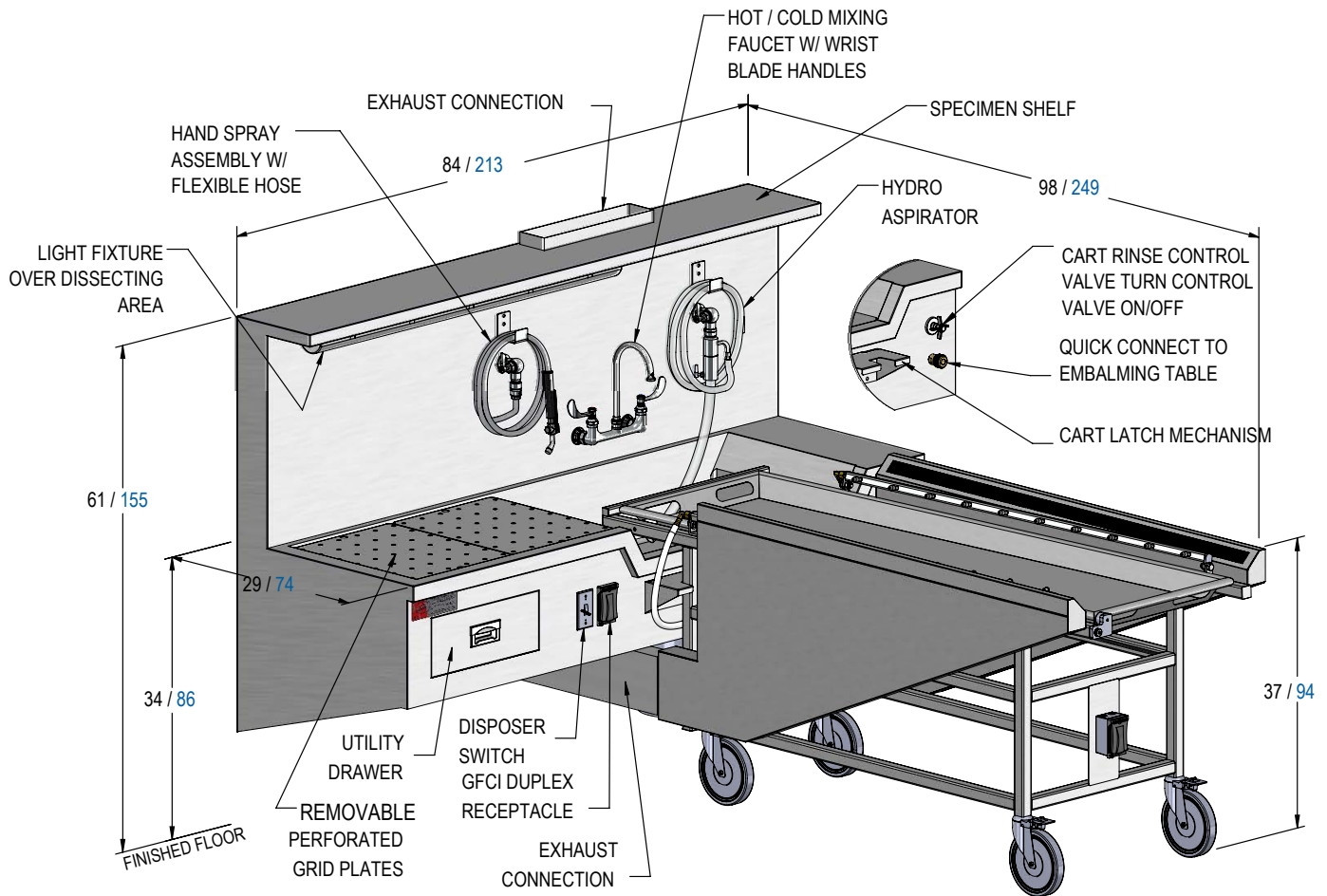

All measurements in inches/centimeters +-

# MODEL 1036-25/600035 LAYOUT DRAWING & OPTIONAL FEATURES

## Options based on available space

When planning an order, we will assist you in selecting options to complete your system. Feel free to contact your sales associate.



**LC-50 - 1/2 HP HEAVY DUTY COMMERCIAL DISPOSER** Standard on most sinks. Variable power options. Available in 1/2, 1 or 2 HP.



**SS-100, SS-200 - HEAVY DUTY COMMERCIAL DISPOSER** Variable power options. Available in 1 or 2 HP.



**OA-100-WM - CO2/NATURAL GAS VALVES** All brass with chrome plated finish. Wall Mounted. Visually marked for type of function required.



**OA-101-WM - COMPRESSED AIR VALVE** All brass with chrome plated finish. Wall Mounted. Visually marked for type of function required.



**OA-102-WM - VACUUM VALVES** All brass with chrome plated finish. Wall Mounted. Visually marked for type of function required.



**OA-111 - EMERGENCY EYEWASH / HOSE ASSEMBLY** Hand controlled spray to provide a gentle flow of water to rinse eyes of foreign debris.



**OA-112 - EYEWASH / FAUCET ASSEMBLY** Deck Mounted Eye wash for hands free eye wash or can be removed for use as a drench hose for eye, face, or body use coverage.



**OA-113 - EYEWASH - FLIP DOWN STYLE** Wall mounted polished chrome-plated brass single action pull down activated eye/face wash.



**OA-150 - SPRAY HOSE ASSEMBLY** Easy grip assembly with flexible hose, conveniently placed for easy spray cleaning.

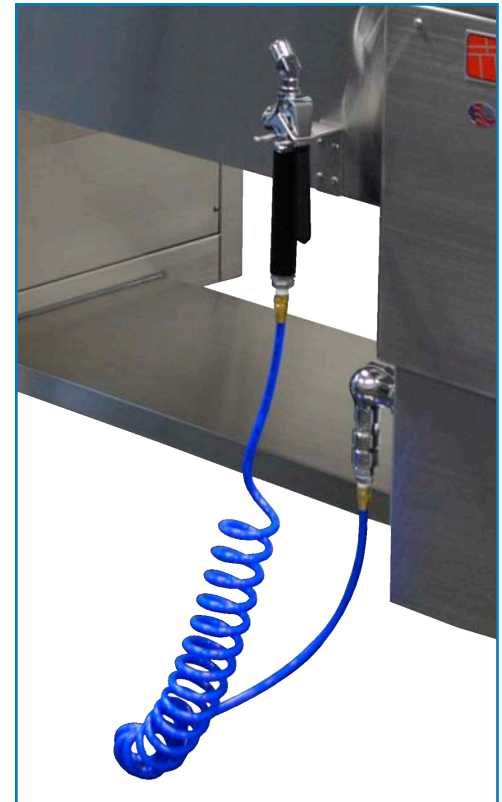

**OA-506 - SPRAY HOSE ASSEMBLY WITH BACKFLOW & RECOIL HOSE** Wash off contaminants and debris with flexible and wide reaching recoil hose.



# SINK STATIONS

## AUTOPSY STATION FEATURES & ACCESSORIES

### Options based on available space

When planning an order, we will assist you in selecting options to complete your system. Feel free to contact your sales associate.



**OA-203 - ADDITIONAL MIXING FAUCET WITH VACUUM BREAKER** Add an additional faucet with vacuum breaker included.



**OA-204 - HANDS FREE MIXING FAUCET** Toggle a steady stream of water with this motion activated sensor.



**OA-225 - SELECTA SPRAY HOSE ASSEMBLY** Ideal for cleaning laboratory glassware, and variety of other instruments using either water or pressurized air.



**OA-226 - SELECTA SPRAY HOSE ASSEMBLY ACCESSORIES** Multi-purpose accessories for cleaning pipettes, syringes, catheters, curettes, endoscopes, cystoscopes, cannulae and a variety of other instruments.



**OA-210 - VENT CONNECTION (TOP SINK)**



**LW480 - HYDRO ASPIRATOR** With built-in vacuum breaker and control lever used to reverse the flow of water directing it through the hose connections for drawing fluid or rinsing.



**LW481 - ASPIRATOR EXTENSION** Fabricated from chrome plated brass, and provides further safety against polluted backflow.



**OA-206 - EXHAUST DUCT**  
8 x 10, Each



**LW482 - NON-CLOGGING ASPIRATOR HEAD** Prevents large debris from entering and clogging the system.



**AHT - TROCAR TUBING**  
10 ft. min., priced per foot. Clear vinyl Aspirator/Trocar tubing. Internal diameter of .375 in. and outside diameter of .625 in.



**AHS - ASPIRATOR DISCHARGE TUBING**  
3 ft. min., priced per foot. Splash tubing for aspirator drain, embalming and autopsy tops. Internal diameter of 1 in. and outside diameter of 1.25 in..

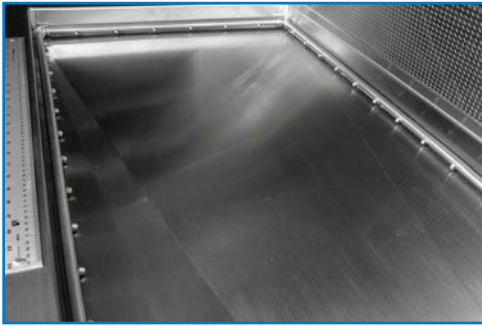

**OA-115 - THREE SIDED RINSE ASSEMBLY**  
Provides a rinse to gently wash debris and non-viable material away from the work area. A sturdy stainless steel assembly controlled by an on/off valve.



**OA-116 - END RINSE ASSEMBLY**  
Provides a constant flow of water beneath the dissecting area grid plates to wash debris toward sink and drain. Includes cold water control valve and back flow protection.



**OA-202 - ELECTRIC ASPIRATOR**  
Diaphragm pump unit designed for high performance, powerful suction capability, when and where you need it at a moment's notice. Accommodates 600 ml. glass bottle or 1100 ml. disposable canisters.



**LW418 - ELECTRONIC SCALE - PLATFORM**  
*6.5 in. x 5.5 in. Platform, 2000g.*  
Compact, lightweight, portable and perfectly suited for laboratory and educational purposes. 2200 x .1 gm.



**LW419 - ELECTRONIC SCALE - PLATFORM**  
*6.6 in. x 6 in. Platform, 2100g.*  
Compact, lightweight, portable and perfectly suited for laboratory and educational purposes. 2200 x .1 gm.

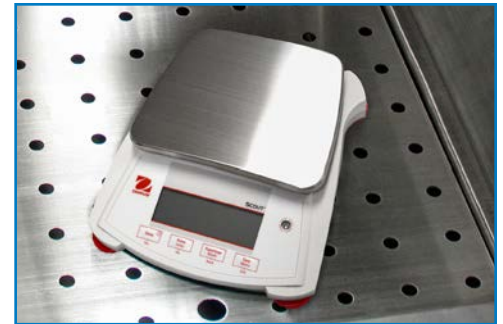

**LW425 - ELECTRONIC SCALE - PLATFORM**  
*6 in. Platform, 2000g.*  
Compact, lightweight, portable and perfectly suited for laboratory and educational purposes. 2200 x .1 gm.



**LW410 - SCALE POLE AND MOUNTING BRACKET**  
For use with standard hanging autopsy scale. Pole can swivel left and right, and includes locking knob. 44 in. length.



**OA-205 - STAINLESS STEEL SCALE SHELF**  
All stainless steel construction adds storage space for accessories. 12 in. x 12 in.

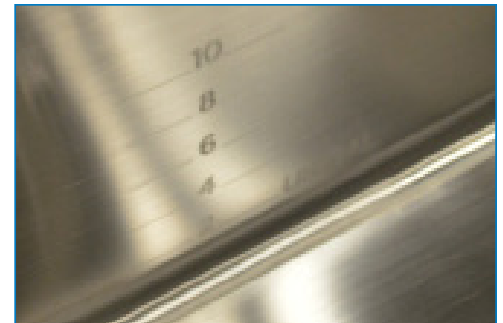

**LASER-ETCHED GRADUATED SINK**  
Keep track of the volume of fluid used.



**LW485 - EVIDENCE SCREEN**  
Designed to prevent evidence from being washed down drain. Fabricated from perforated stainless steel. For use in 3.5 in. diameter drains.



**LW487 - ORGAN RINSE BASKET**  
Designed to hang on the interior of the sink basin. Ideal for rinsing organs. Fabricated from stainless steel with a perforated bottom.

**Options based on available space**  
When planning an order, we will assist you in selecting options to complete your system. Feel free to contact your sales associate.



## SINK STATIONS

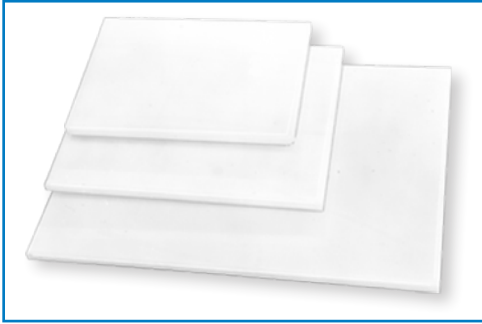

**LW385, LW386, LW387 - DISSECTING BOARDS** Available in 24 in. x 18 in., 18 in. x 12 in. & 20 in. x 15 in.

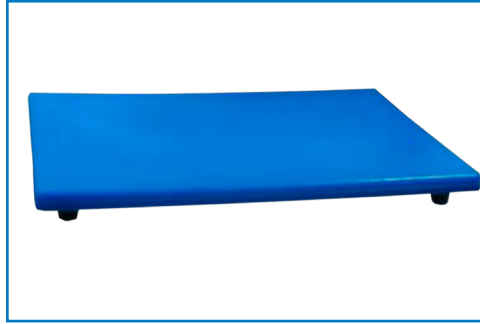

**LW389 - PHOTO-BLUE DISSECTING BOARD** Manufactured from high-density polyethylene, providing an excellent cutting surface. Bottom corners have a non-skid rubber foot attached.



**LW379 - DISSECTING BOARDS w/ 3 in. LEGS** Manufactured from high density polyethylene. Provides an excellent cutting surface. 20 in length x 15 in width x .7 in thick cutting board



**LW379A - RAISED DISSECTING PLATFORM** Manufactured from high density polyethylene with adjustable legs. Provides an excellent cutting surface. Color is photo blue.



**LW380 - INSTRUMENT DISSECTING TRAY** Stainless steel construction. Heavy gauge material provides a highly stable work surface. Tray creased toward center drain with optional hose attachment to route flow. Custom heights available.



**LW392 - RAISED BODY BOARDS** Elevates body away from work surface.



**MDA-20W - WALL-MOUNTED FORMALIN SPIGOT** Conveniently placed formalin supply spout.



**OA-201 - FORMALIN DISPENSING AND COLLECTION** 2.5 gal. container and receptacle hold reserve formalin and collects waste. Foot controlled motor dispenses formalin at a steady flow.



**OA-147-1, OA-147-2, OA-147-3 GLOVE BOX HOLDER** Stainless Steel support to hold latex and nitrile glove boxes, holders come in a side or top load model. Available in 1, 2, & 3 capacity.



### Options based on available space

When planning an order, we will assist you in selecting options to complete your system. Feel free to contact your sales associate.



**OA-144 - MAGNETIC INSTRUMENT HOLDER**  
Conveniently store and organize your instruments.



**LW390 - HEADREST**  
(LW390A - available in aluminum)



**OA-209-84, OA-209-114, OA-209-132 - STAINLESS STEEL LEG ASSEMBLY**



**OA-208 - INTEGRAL RAISED DISSECTING AREA**



**HEIGHT ADJUSTABLE SINK MOUNT STRUCTURE & SURGICAL LIGHTING**

## CUSTOM LAYOUT AND DESIGN

We understand that every project is unique. If you have special requirements, we can modify the stations to suit your needs. A custom layout can consist of modifications to allow larger or restricted work areas, additional utilities, shelving, drawers and ventilation.

Pictured accessories may differ depending on your unit and other optional accessories. Please review the model's standard features to ensure accuracy of specifications.