

REFRIGERATION SYSTEMS

STANDARD DESIGN FEATURES

Dimensions

Width: 143 in./358 cm.
Depth: 97 in./246 cm.
Height: 83 in./211 cm.

Doors (8)

Width: 27 in./68 cm.
Height: 22 in./55 cm.
• Overlap door w/ magnetic gasket

Installation

• Unit ships knocked down and will require assembly

Exterior of Box

• Front - .032 in. Type 304 stainless steel with a No. 4 finish.
• Top, sides, and back - .040 in. stucco embossed aluminum

Interior of Box

• Walls & ceiling - .040 in. stucco embossed aluminum
• Floor .032 in. smooth aluminum with .75 in/2 cm. CDX plywood reinforced understructure

Insulation

• 4 in./10 cm. foamed in place urethane (UL listed, Class 1)

Rack System

• (8) three piece telescopic fabricated of extruded aluminum with nylon rollers

Removable tray

• (8) 18 gauge Type 304 stainless steel w/No 4 finish

Hardware

• Heavy-duty chrome plated hardware for long lasting use

Lighting

• (1) vapor proof light w/switch

Refrigeration

• Drop-in self-contained refrigeration system with digital thermometer and easy to adjust temperature controller

Operating temperature

• 38°F/3.3°C

Electrical

• ~208-230V/50-60Hz/1 Ph

**Freezer model available:
Model 1036-F111 Freezer
operating temp. 0°F/-17.8°C**

OPTIONAL FEATURES

• Custom sizes for larger cases
• Full length interior roller racks
• HD plastic storage boards

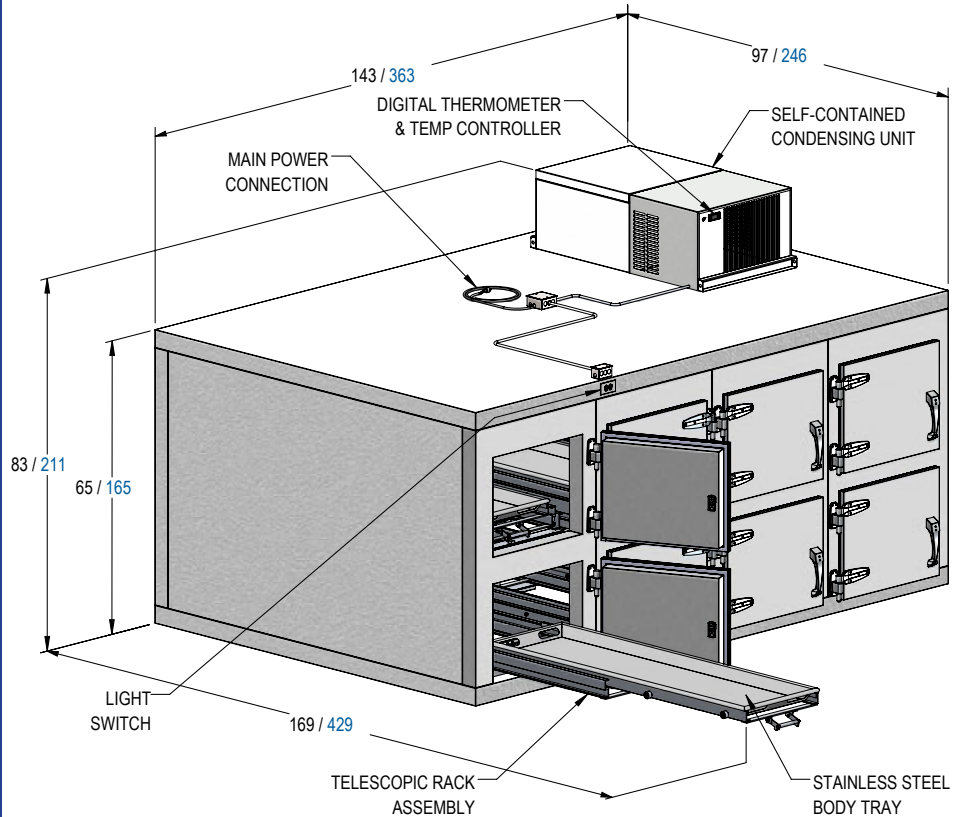

~208-230V/50-60Hz/1 Ph Model Shown

MODEL 1036-R111 EIGHT BODY REFRIGERATOR

411 North Aerojet Avenue
Azusa, CA 91702
www.mortechmfg.com

T(800) 410-0100
T(626) 334-1471
F(626) 334-1704