

INSTALLATION GUIDE

PORTABLE WATER SOFTENER | WS-P-16

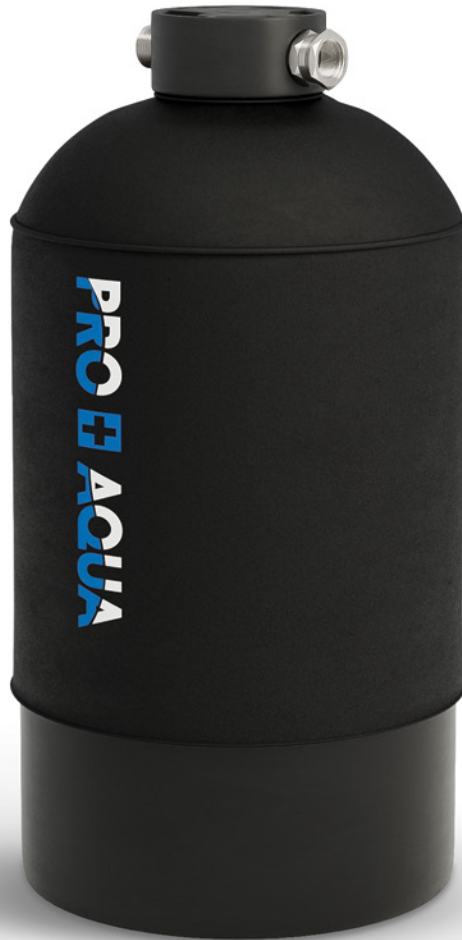

PRO+ AQUA

PURE WATER. NOTHING ELSE.



PURE WATER. NOTHING ELSE.

PRO+AQUA filtration systems are designed in California, USA and are made from high quality, commercial grade filters and components.

CAUTION:

Before using this water softener, read this manual and follow all operating instructions for maximum protection against hard water.

Record the date of purchase in your manual for future reference:

Date of purchase: _____

System Inspection Before Starting

Remove the system and all components out of the box, and take note of all parts. Inspect the system carefully, ensuring nothing was damaged during transit. If any part is cracked or damaged, please do not proceed with the installation and contact **PRO+AQUA** for an exchange or diagnosis.

Components List:

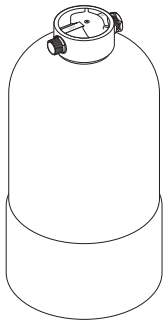

WS-P-16 Water Softener

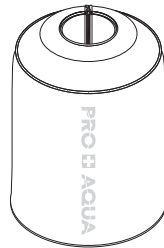

Neoprene Protective Cover

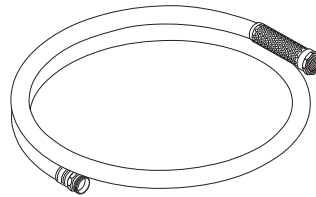

5' Hose 3/4" Connection

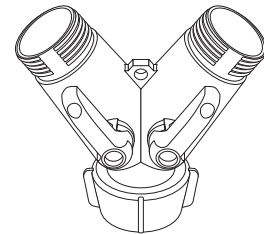

Y-Splitter

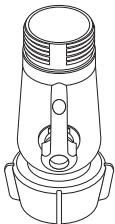

Shut Off Valve

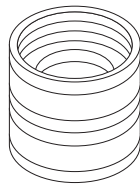

Brass Double Female Hose Adapter

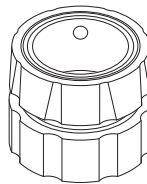

Brass Female Hose QC Adapter

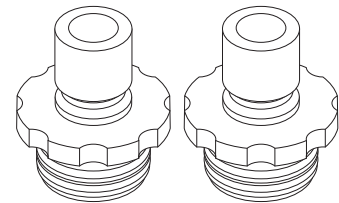

2 Brass Male Hose QC Adapters



Don't miss out on **TWO (2) FREE YEARS** of additional system coverage

The WS-P-16 includes a one-year warranty. Register your product within 60 days from time of purchase to add two years of protection covered under our **PRO+AQUA** warranty.

1. Locate the serial number on the system.
2. Visit www.proaquawater.com/warranty-reg
3. Enter your purchase and serial number information.

No time to go online?

Let our **PRO+AQUA** Certified Tech Team do the work for you. Simply follow the steps below and in 2-3 working days we'll send you confirmation of your product being registered.

Purchaser Name: _____

Email: _____

Phone: _____

Address: _____

City: _____

State: _____

Zip: _____

Order Number: _____

Order Date: _____

Serial Number: _____

Place of Order: _____

Registration with your mobile device is easy.

1. Fill out the form by handwriting your info.
2. Take a picture of the form with your device.
3. Scan the QR code with your device camera and click the banner that appears.
4. Attach the picture of the form to the email that opens.
5. Hit Send and you're DONE!





Pre-flushing Your System

Overview:

This portable water softener comes with new resin and is ready for use as soon as backwashing is completed. Below is an overview of all of the components. To the right is a simple step-by-step guide to pre-flush your system.

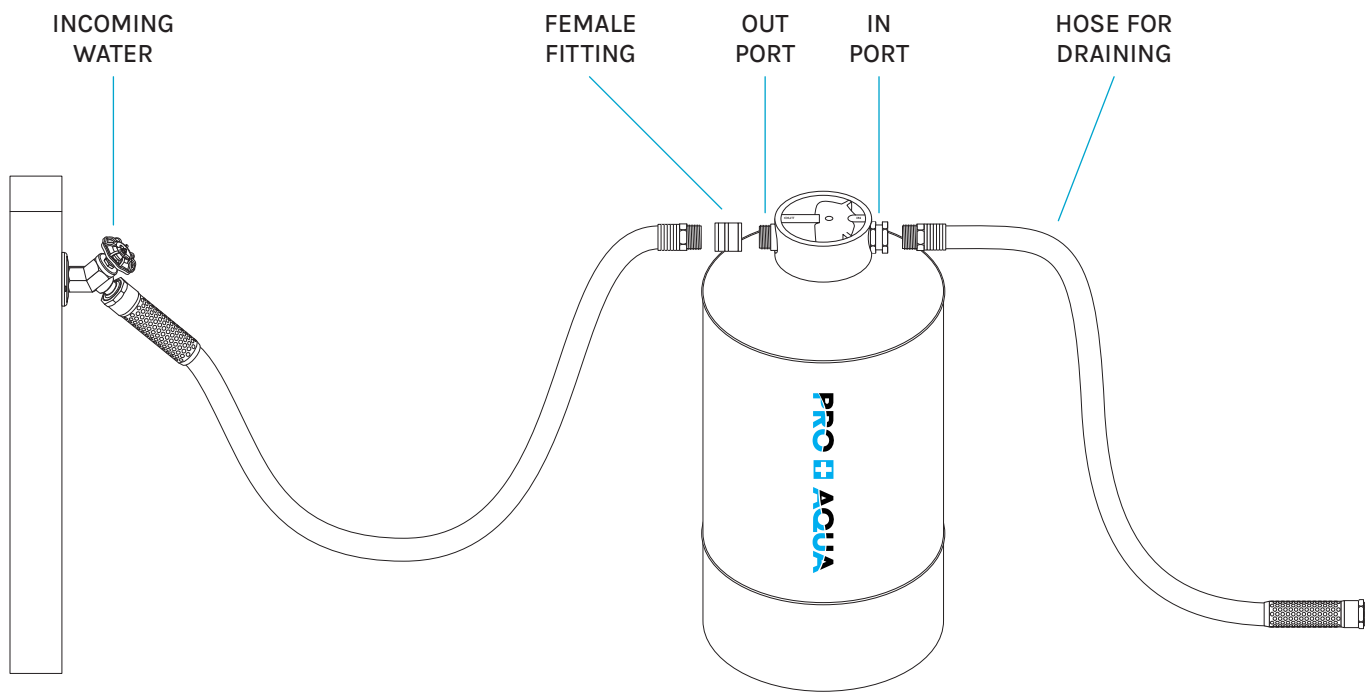



1

Connect your incoming water hose to the “OUT” port on the tank head. Use the supplied female fitting if needed.

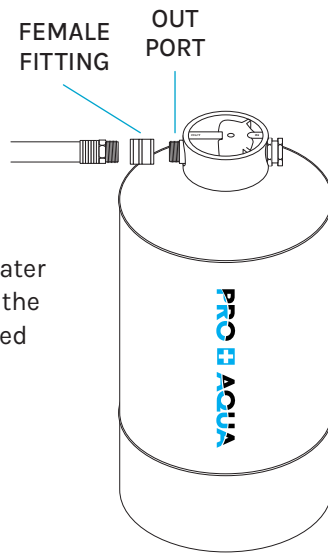

2

Attach another garden hose to the “IN” port on the head and direct it to a drainage area or driveway. If no garden hose is available, place the unit on level ground with space to release water. **Make sure the unit is upright.**

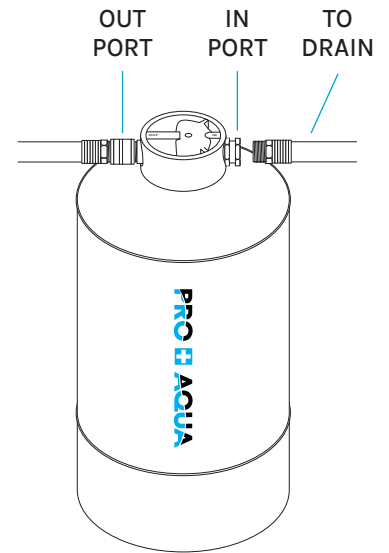

3

Turn the water on and flush the unit for 5 minutes, until the water flows clear. It is normal to see color and/or particles on your first flush.

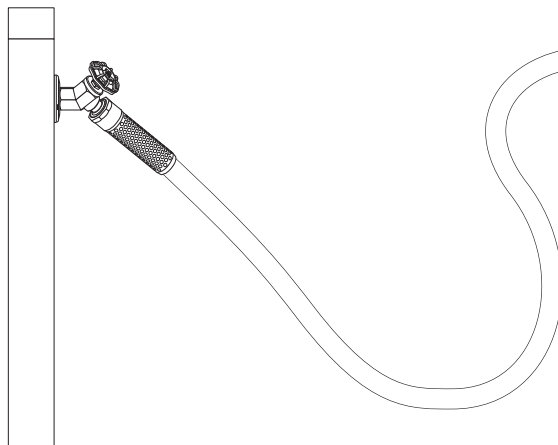

4

Complete. You can now connect and use the softener.

OUT PORT IN PORT

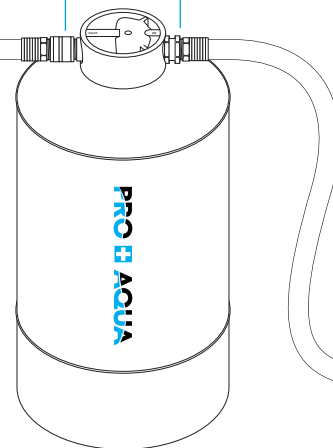

DRAINED WATER

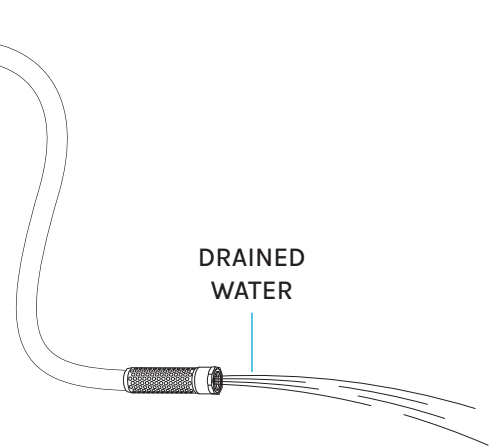



Setup For Use

Overview:

It is highly recommended to use a pre-filter. Use a CTO pre-filter like the WS-P-REG-KIT to protect the softener and increase the quality of your water. Below is an overview of all of the components used for this process. To the right is a simple step-by-step guide.

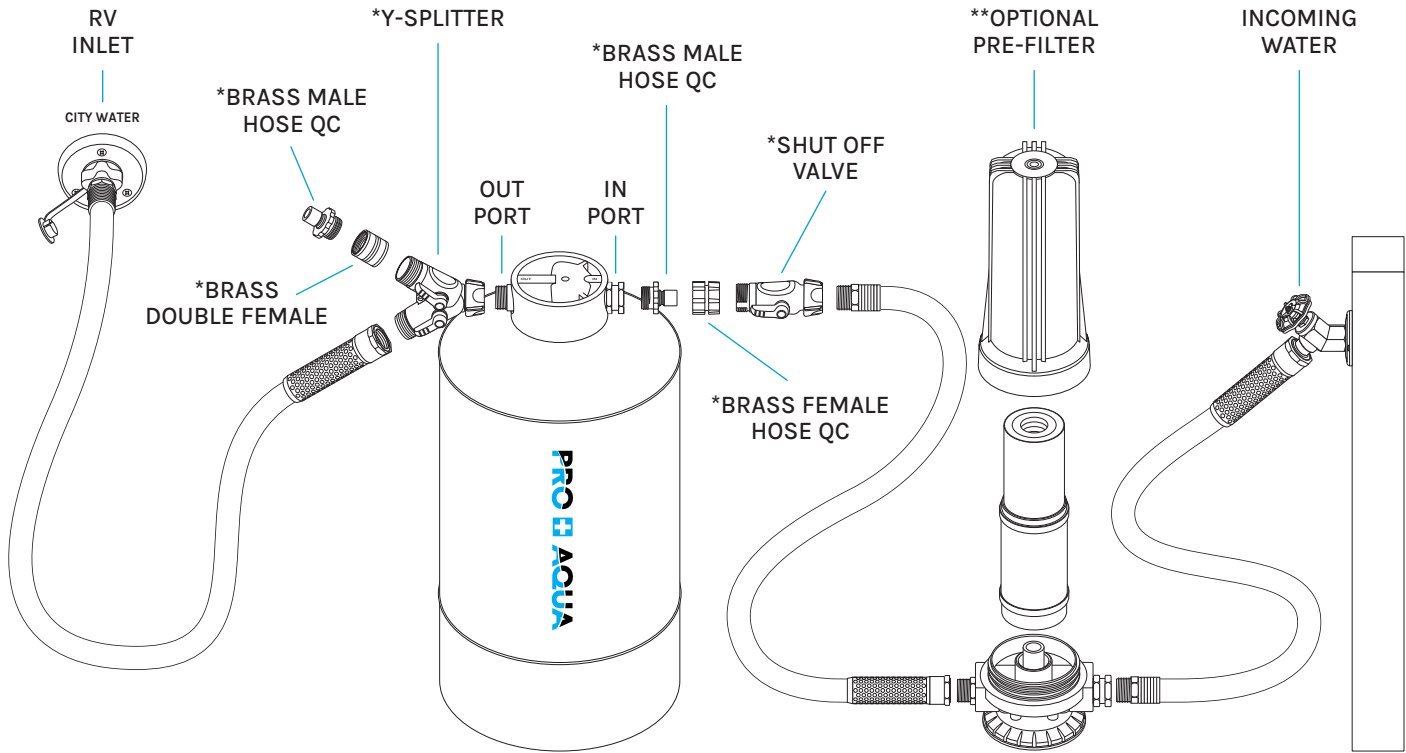

More info



*Included with your system as optional items.

**Sold separately.



1

Simple setup. Connect your incoming water hose to the “IN” port of the unit.

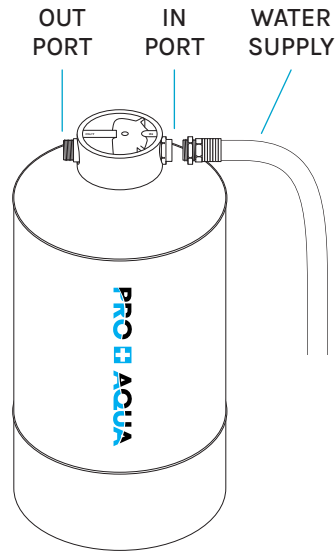

2

Connect a secondary hose to the “OUT” port of the unit.

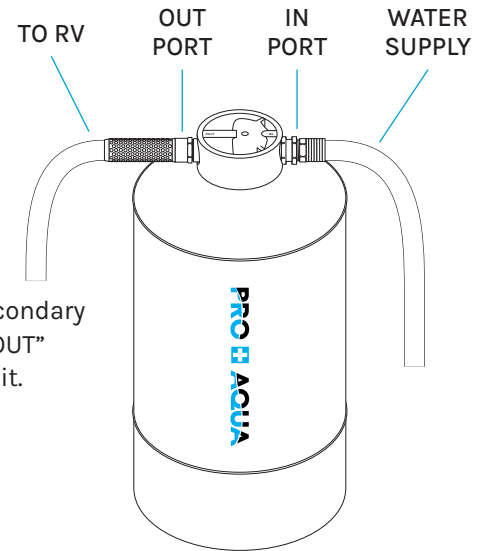

3

Direct the hose from the “OUT” port of the softener to the “City Water Connection/City Fill” inlet on your recreational vehicle.

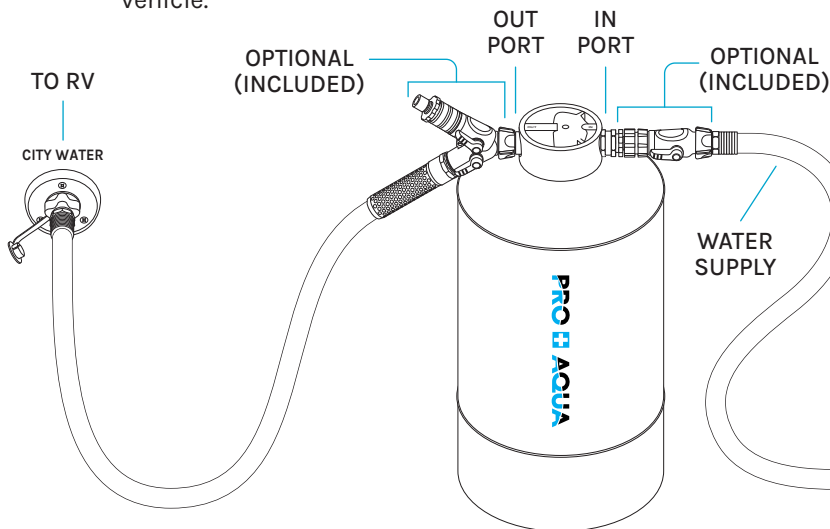

4

A: Securing the unit with a strap is recommended if installing for travel in your RV. **B:** The unit must be installed upright - never install the portable water softener on its side. **C:** Complete. Your system is now ready for use.

OPTIONAL
PRE-FILTER

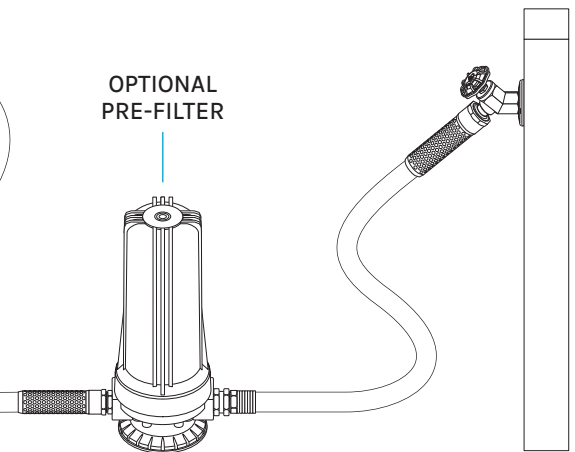



Regenerating Instructions

Regenerating instructions with the optional WS-P-REG-KIT kit. Scan code to the right for more info:



More info
WS-P-REG-KITV2

1

Remove pre-filter if installed. Fill the WS-P-REG-KIT housing 1/4" below the O-ring with about 2-3 lbs (1-2 boxes) of standard table salt and reattach base by turning housing clockwise. Clean any excess salt from the O-ring to form a secure seal and stand kit on floor.

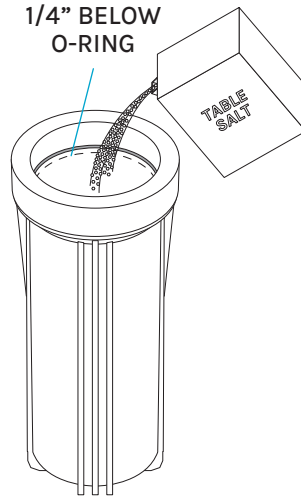

2

A: Connect the incoming water line to the "IN" port of the housing base.
B: Screw one of the quick connect brine hose fittings to the "OUT" port of the housing base, and secure white brine line by pressing in 1/2" and pulling to make sure it's set.

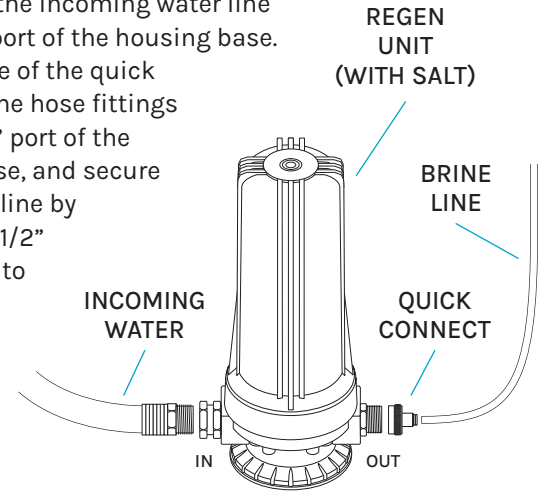

3

Screw the other quick connect brine hose fitting to the "OUT" port on the softener tank head, and insert white brine line by pressing in 1/2" and pulling to make sure it's set.

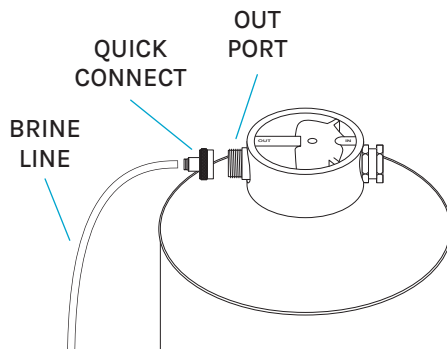

4

A: Turn water on slowly until only a pencil size stream is flowing from the "IN" port of the head for 20-30 minutes. This water contains high amounts of salt. **DO NOT drain on grass, flowers, or trees.**
B: After 20-30 minutes, turn the water on high for an additional 10 minutes.

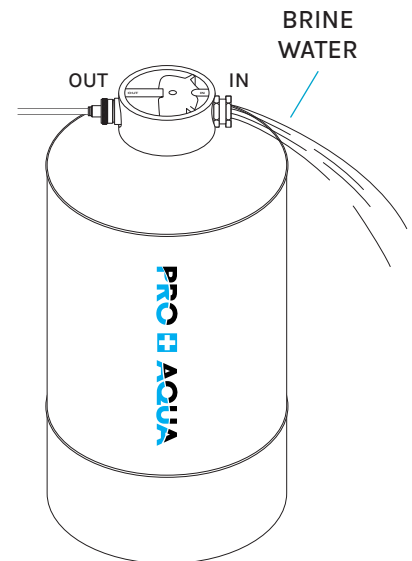



Regenerating instructions without the WS-P-REG-KIT kit:

1

Disconnect hoses and lay the unit on its side to drain water out, then stand upright.

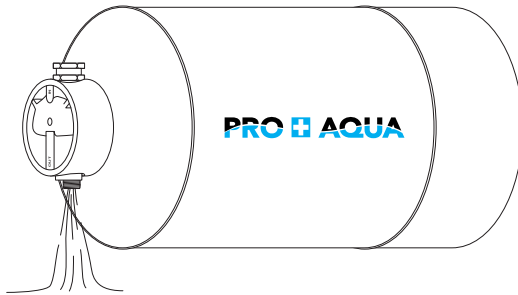

2

A: Remove the head of unit by turning counterclockwise and pour 4 lbs of table salt directly into the unit.
B: Replace the head of the unit after salt has been added. Let the unit stand for 40-50 minutes and agitate/shake every 10 minutes.

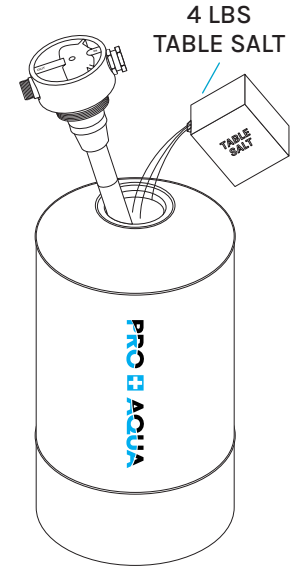

3

Ensure the unit is upright and leveled. Connect your incoming hose to the “OUT” port on the unit. Connect an additional hose to the “IN” port on the unit or place the unit on a driveway if a hose is not available as the drain water contains high amounts of salt. **DO NOT drain on grass, flowers or trees.**

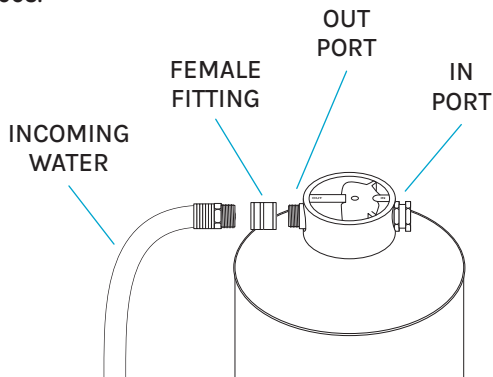

4

A: Turn water on slowly until only a pencil size stream is flowing from the unit for 10-15 minutes, then turn the flow all the way on for 1-2 minutes.
B: Once the unit has no salt water coming out, your unit is ready for use!

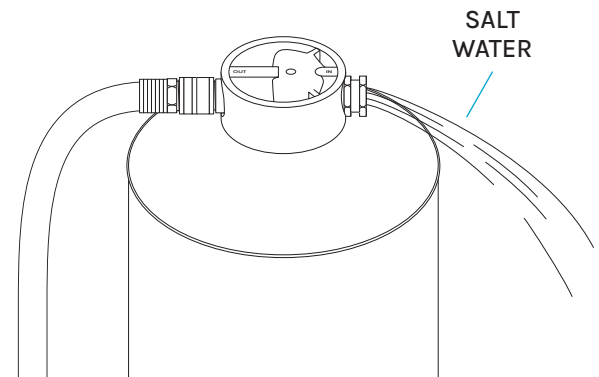



How to store the water softener when not in use?

To store the system, first regenerate it, empty some of the water out, and place it in a cool area away from the sun. You can place a bag over the head to keep the ports clean. Depending on how long you store it, you can flush out the old water and continue using it or you might need to mix a little chlorine to kill any bacteria that could have grown in the unit. Keep in mind however that chlorine destroys the resin and frequent sanitation will break down the beads.

How to empty the resin tank?

Remove any connections and lean it on its side. When the water stops, pick it up from the bottom to remove the remaining water. There is a basket under the cap that keeps the media from spilling out.

How often should I regenerate?

Divide 16,000 by your local water hardness to determine gallons between regenerations.

Can I travel with this unit laying down?

Well sealed, it should travel just fine on its side. Allow some time for the resin to settle after setting up before operation.

Additional tips:

Always regenerate before storing and never let the unit freeze or dry out.

System Maintenance

All of our systems require little maintenance. The only regular maintenance required is regenerating the softener when the capacity has been depleted and changing the resin every 1-3 years (depending on usage and water quality). Using the WS-P-REG-KIT will protect the resin and extend the life of the media. The WS-P-REG-KIT filter should be replaced every season (3-4 months, depending on usage and water quality in your area).

Quick Order Links:

Scan here to order the
Regeneration Kit



Scan here to order
Replacement Resin





More than filtration – it's peace of mind.

PRO+AQUA: Redefining Water Filtration. Unmatched Performance.
Uncompromising Quality.

Explore more at www.proaquawater.com!

PRO+ AQUA

PURE WATER. NOTHING ELSE.

For assistance, please feel free to reach
out to us Mon - Fri 9am - 5pm PT
(800) 980-3335 or via email at
hi@proaquawater.com

www.proaquawater.com

