



PRO+RO SERIES USER & SERVICE MANUAL

TABLE OF CONTENT

Introduction / System Specifications	3
1. Principles of Reverse Osmosis	4
- Reverse Osmosis Process	4
- Semipermeable membrane	4
- Factors affecting membrane service life	4
- Reverse Osmosis System Terms and Definitions	4
- Feed Water requirements	5
2. Identifying System Components	5
3. Pre Installation References	7
4. Reverse Osmosis System Installation	7
5. Membrane Installation	7
6. Controller programming	8
- Controller screen	8
- Navigation and Programming Menu	8
- Controller Programming	8
- Information displayed on screen	9
- Settings Parameter	9
- Cable connection identification	10
- Calibration of TDS sensor	10
- Control box features	10
7. Start-Up	11
- Initial tests	11
8. Troubleshooting Guides	12 - 13
9. Reverse Osmosis Pre-Treatment	14
Warranty	15



WARNING! READ ENTIRE MANUAL COMPLETELY. FAILURE TO FOLLOW ALL GUIDELINES COULD CAUSE PERSONAL INJURY OR PROPERTY DAMAGE.



REVIEW AND FOLLOW LOCAL LAWS REGARDING PLUMBING INSTALLATION OF THIS EQUIPMENT.



WARNING! DO NOT USE WITH WATER THAT IS MICROBIOLOGICALLY UNSAFE OR OF UNKNOWN QUALITY WITHOUT PROPER DISINFECTION BEFORE OR AFTER THE EQUIPMENT.

NOTE: Failure to comply with these instructions will void equipment warranty and the installer will be responsible for service, damages and repairs.

INSPECTION & PREPARATION

INTRODUCTION

Water is an important part of all process applications. In order to always provide the highest quality of water to the end consumer, we must make sure to have all the required parameters for each application. Correct information is important in order to safeguard the welfare of consumers when it comes to water quality for food processing, beverages or whatever the final application may be. Proper selection of treatment technology must be evaluated in a case by case basis.

The physical, chemical and microbiological characteristics of water vary from one source to another. Proper water analysis is important in order to know the unique parameters of the water to be treated. Remember that water is a universal solvent and each water supply has different quality characteristics.

It is worth mentioning that in water analysis: dissolved solids (ions or dissolved minerals) whose concentration determine water salinity is measured as TDS (total dissolved solids) or electrical conductivity. Suspended solids and colloids are the ones that give the characteristics of water turbidity. Organic components and micro-biological and other chemical parameters such as pH, dissolved gases, hardness, silica and dissolved metals are equally important to determine the quality of incoming water to any water conditioning process.

PRO+AQUA PRO+RO Series Reverse Osmosis systems have been designed and tested to provide high quality water and have been built with quality components that provide you not just high grade water, but also gives you full confidence in its operation and durability.

SYSTEM SPECIFICATIONS

PRO+RO Series Models:

MODEL:	PRO-RO-II	PRO-RO-IV	PRO-RO-VI	PRO-RO-VIII	PRO-RO-XIV
PRODUCTION (GPD)	2,100-2,400*	4,200- 4,800*	6,300-7,200*	8,400-9,600*	14,400-15,600*
MEMBRANE	4" x 40" (1)	4" x 40" (2)	4" x 40" (3)	4" x 40" (4)	4" x 40" (6)
PRODUCT (GPM)	1.45 - 1.6	2.9 - 3.2	4.3 - 4.8	5.8 - 6.4	10 - 10.8
FEED FLOW (GPM)	5	8	10	20	25
% RECOVERY	50-60 %	50-60%	50-60 %	50-60 %	50-60 %
HIGH PRESSURE PUMP	1.5 HP	1.5 HP	1.5 HP	3.0 HP	3.0 HP
INLET PORT	3/4"	3/4"	1"	1"	1"
PRODUCT OUTLET PORT	1/2"	1/2"	3/4"	3/4"	1"
WASTE OUTLET PORT	1/2"	1/2"	3/4"	3/4"	1"
SYSTEM DIMENSIONS	20" x 20" x 47"	20" x 20" x 47"	25" x 20" x 47"	25" x 20" x 47"	50" x 30" x 50"
WEIGHT (LBS)	176	187	218	242	270
ELECTRICAL POWER SUPPLY	120 or 220 V	120 or 220 V	120 or 220 V	220	220

* The system production rate is based on minimum feed water quality below 1,000 PPM, feed water temp 77 °F, and SDI < 5. Use a suitable pretreatment capable of removing all membrane damaging substances.

If you purchased any of these systems with some variation or special design and it is not described in this manual, please contact us indicating the corresponding serial number.

Please read the information contained in this manual before starting operation of the reverse osmosis system. Any misapplication could void the warranty or cause equipment damage.

- ! > THIS REVERSE OSMOSIS SYSTEM IS DESIGNED FOR WATER PURIFICATION PURPOSES ONLY.
- ! > THIS REVERSE OSMOSIS SYSTEM MUST BE PROTECTED FROM NATURAL ELEMENTS. RAIN AND EXPOSURE TO UV RAYS CAN CAUSE PERMANENT DAMAGE TO THE SYSTEM.
- ! > EXPOSURE TO VERY HIGH HUMIDITY MAY CAUSE DAMAGE TO PUMP MOTER AND ELECTRONIC CONTROLS.

PRINCIPLES OF REVERSE OSMOSIS

1 > Principles of Reverse Osmosis Technology

How the Reverse Osmosis process works?

Reverse Osmosis (RO) is a process in which water is forced to pass through a semipermeable membrane by pressure.

As the water passes through the membrane dissolved particles are rejected by the membrane in its spiral layers of semipermeable material formed around a central perforated tube.

Semipermeable membrane

The reverse osmosis system uses the properties of a microporous membrane that works as an efficient particulate filter up to the size of chemical molecules or ions. The rejection of these particles is compared to molecular weight and ionic charge. For example, we can expect a 90% rejection of sodium chloride, which means that the product passing through the membrane will have a concentration of about one tenth of the incoming water. The rejection of calcium carbonate (hardness) will be about 95%, while most of the salts will be rejected approximately 98% to 99%.

Ion rejection or organic material is basically done by mechanical filtration. Most substances with molecular weight of more than 100 will be completely rejected by the membrane. Particles with very low molecular weight such as formaldehyde or free phenol can pass through the membrane (RO), like most dissolved gases.

Disposal of unwanted particles is accomplished by constant flow of water that is circulating, making the function of rinsing the membrane, which prevents saturating surface and reduces the tendency to form scale.

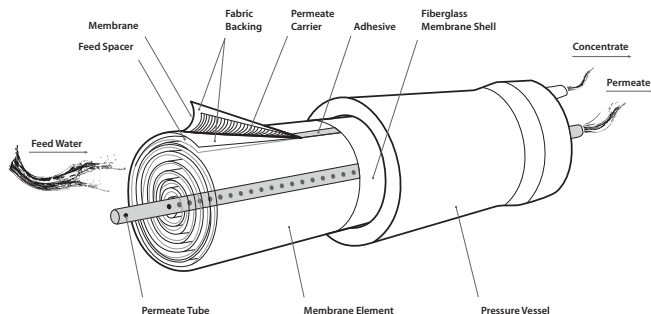

Factors that affect the operation and life of the membrane

There are five main factors affecting the reverse osmosis membrane:

1. Pressure: Excessive pressure may deform and compress the membrane which can cause decrease water production.

2. Hydrolysis: It is a chemical reaction of water that affects the membrane. This happens when the water temperature is very high and the pH is below 2.5 or above 7. To avoid this, keep the pH between 5 and 6.

3. Bacterium: The presence of bacteria deteriorates the surface layer of the membrane and reduce the ability of the membrane to reject salts.

4. Temperature: Avoid temperatures above 95 ° F (35 ° C) to avoid damaging the membrane structure.

5. Saturation: These are salts (calcium carbonate, etc.) that are precipitated on the membrane. These salts clog the pores and channels reducing the amount of water produced.

Temperature in reverse osmosis units:

The units are designed for a temperature of 77 ° F (25 ° C). The production flow is reduced at low temperatures. On average membranes lose at least 1.8% of production for each degree below 77 ° F.

Some common terms and definitions related to reverse osmosis

Incoming (feed) water - Pre-filtered and softened water introduced to the reverse osmosis modules.

Product Water - Purified water produced by reverse osmosis membranes.

Water Concentrate (rejection) - High waste containing water (reject) that goes directly to the drain.

Membrane - Internal semipermeable element core of your reverse osmosis system.

Module - is the complete membrane inside a pressure vessel

GPD (Gallons per day) - Unit of measure which determines the water production of the membranes. Example: A system 1,000 GPD reverse osmosis will produce 1,000 gallons of pure water in a 24 hour period (maximum working 24 hours / day).

PPM (Parts per million) - Method used to measure the quality of water in the reverse osmosis.

Percentage Recovery - The amount of water recovered through the membranes. Example: If you enter 100 gallons of water into the membrane, and produce 60 gallons of clean water to 40 gallons of reject water, this means the RO System has a 60% recovery.

Percentage Rejection - The amount of salts and chemicals rejected or removed by reverse osmosis membranes.

PRINCIPLES OF RO & IDENTIFYING SYSTEM COMPONENTS

Feed Water Requirements

TYPICAL EXPECTED ION RETENTION IN A TFC MEMBRANE TYPE:

Typical Expected Ion Retention In A Tfc Membrane Type	
Sodium	85-94 %
Lead	95-98 %
Sulfate	96-98 %
Arsenic	92-96 %
Calcium	94-98 %
Magnesium	94-98 %
Potassium	85-95 %
Nickel	96-98 %
Nitrate	60-75 %
Fluoride	85-92 %
Iron	94-98 %
Manganese	94-98 %
Zinc	95-98 %
Cadmium	95-98 %
Mercury	95-98 %
Barium	95-98 %
Selenium	94-96 %
Cyanide	84-92 %
Phosphate	96-98 %
Chloride	85-92 %

WATER SUPPLY REQUIREMENTS:

Typical Retention Of A Reverse Osmosis Membrane	
Temperature	8-27 C
Hardness	< 20 PPM
Residual chlorine	0 PPM
Tds	< 1000 PPM
Ph	3 A 11
Iron	< 0.01
Silica	< 10 PPM
Manganese	< 0.05 PPM
Inlet pressure	30-60 PSI

2 > SYSTEM COMPONENTS

1. PREFILTER PRESSURE GAUGE: Glycerin filled pressure gauge (0-100psi). Standard on all units and is located on the front of the panel. This gauge measures the water pressure in PSI at the outlet of the pre-filter, a minimum pressure of 30 PSI is recommended

2. SYSTEM PRESSURE GAUGE: Glycerin filled pressure gauge (0-300psi). Standard in all units. Located in front of the panel and senses the pump pressure discharge. This gauge measures the pressure of water in PSI which is applied through the membrane. (Maximum recommended operating pressure is 180-200 PSI, depending on the type of membrane).

The operating pressure of the system can be adjusted by regulating these combined valves:

- Turning waste valve handle to the right the pressure increases; turning the valve handle to the left pressure will decrease.

! > CAUTION! Do not close this valve completely.

- By adjusting the recirculation valve located next to the waste valve above. Turn right to increase pressure and close recirculation flow or turn the handle to the left to decrease pressure and open recirculation flow.

3. CONCENTRATE WATER FLOWMETER (WASTE): Located on the front of the panel, this meter is calibrated in gallons per minute. Its purpose is to measure the amount of waste water that the system is producing.

4. PRODUCT WATER FLOWMETER (PERMEATE): located on the front panel, its purpose is to measure the amount of product water in gallons per minute.

5. RECIRCULATION FLOW METER: Located on the front panel, its purpose is measure the amount of waste water that it returns to feed the system and is blend with raw water.

6. REVERSE OSMOSIS MODULE: It consists of a membrane housing and the membrane. The assembly is placed vertical on TRITTON PRO+RO models.

7. WASTE VALVE: This valve is located on the front panel. Its purpose is to restrict the flow of water concentrate leaving the module, it creates the necessary pressure inside the module so that water is forced into the membrane creating the reverse osmosis effect.

IDENTIFYING SYSTEM COMPONENTS

Turning the valve knob will control the ratio of water discharged / water produced.

- Turning clockwise will increase pressure inside of the module and reduce the amount of waste water.

- turning counterclockwise pressure will decrease within the module and increase the amount of waste water.

! > **CAUTION!** Keep in mind the recovery (product / rejection) suggested by your dealer based on water analysis done.

! > **CAUTION!** Waste valve should never be completely shut.

! > **WARNING!** Do not exceed the recommended pressure of membrane parameters.

8. RECIRCULATION VALVE: This valve is located on the upper front panel. Its propose is to adjust the amount of waste water that recirculates into the feed water of the system. It is used to refine and adjust pump pressure. You should be careful of the characteristics of the incoming water, not to exceed the rate of salinization with imbedded tendency such as calcium, magnesium, silica and avoid membrane fouling problems.

9. THROTTLING VALVE: located on the output of the high-pressure pump, it is used to adjust supply pressure and flow. Depending on the type of membrane used it adjusts flow and pressure.

10. PRE-FILTER: This filter is a 5-micron pre-filter. It is used to remove any particles that may have passed through pre-treatment or released by pretreatment materials. If the cartridge is dirty it can cause loss of pressure. See Reverse Osmosis Pretreatment section on page 11 to find out the kind of filter that is recommended.

! > **NOTICE:** Never use this filter as the only way of Pretreatment for your reverse osmosis system.

11. HIGH PRESSURE PUMP: This creates high pressure for proper reverse osmosis operation. This pressure is adjusted by the waste valve and the recirculation valve.

! > **CAUTION!** Never use the pump without water.

12. CONTROL BOX: The Reverse Osmosis system is designed to be automatically operated by an electronic control. The Controller monitors the operation parameters of the system and sends continuous information to the screen.

In addition, the system has security features integrated into its design to protect components and continuously monitor the quality of product water produced.

Pump Motor overload - Amperage surges are addressed by a thermal relay located on the starter installed for the high-pressure pump.

Start Timer delay - The start delay or pump start delay is 10 seconds. This helps detect potential problems with the solenoid valve or voltage spikes.

Low Pressure Switch - Protects the high-pressure pump to not operate without water, detects no or low pressure in the system and immediately shuts down the system and sends a notice to the screen. Low pressure switch is activated at 10 PSI.

Tank Level Switch - Installed in the product water storage tank. It controls the level and sends a stop signal to the system when tank is full to prevent overflow.

Product Water Quality Sensor - The system has an integrated TDS sensor for monitoring water quality and is constantly visible on the control screen. The TDS sensor can be read in PPM and can be set to trigger an alarm if water quality is abnormal.

Fast Flush - The system can be enabled (*optional*) for an automatic flush to be performed every 2 hrs. (*time can be varied in programming*). If programmed a solenoid opens, the system is depressurized for the selected amount of time and waste water is purged to help protect the system from fouling membranes.

13. INLET SOLENOID VALVE: Normally closed solenoid valve (NC). This valve is located on the feed side of the pressure pump. Its purpose is to stop the water supply when the unit is not operating. If the power fails, this valve will close.

PRE INSTALLATION REFERENCES & REVERSE OSMOSIS SYSTEM INSTALLATION

3 > PRE INSTALLATION REFERENCES

Inlet Feed Water - enters through the pre-filter housing. The housing connection is ¾" or 1" depending on the model. We suggest system connections are made preferably with PVC SCH 80 or SCH 40.

Outlet Product Water - On PRO+RO systems, the permeate water output exits through the product water flow meter, through the back of the system.

Outlet Waste Water - On PRO+RO models, waste water or concentrate exits the reject water flowmeter through the back of the system.

Control Box Power and Voltage Connections - The PRO-RO-II and PRO-RO-III are supplied with standard 120 volt, single phase connections. In situations where the customer specifies otherwise, there may be changes in this regard. All systems must be installed in accordance with local regulations.

All PRO+RO Commercial RO Systems use a 120V, single-phase voltage in the control box and can be converted to 220V. PRO-RO-VIII and PRO-RO-XIV models come in 220V and cannot be converted to 120V.

Switch and Product Water Level Connections in the Storage Tank - The cable connections of the liquid level switch are located directly on the top side of the electrical control box. The two wires are connected together with the level switch cables. When the switch is closed, the reverse osmosis system is switched on. When the switch is open the reverse osmosis system is switched off.

! > It is extremely important to make sure you know all regulations pertaining to local, building, electrical and plumbing parameters of the site where you are installing the system.

4 > REVERSE OSMOSIS SYSTEM INSTALLATION

INSTALL FOLLOWING THESE STEPS:

1. Choose a place that is covered and has enough space for the system. The location should also have feed water, electricity and a specified area for drainage. It is not recommended to install the system in an area exposed to the elements.

- Start by connecting all water connections to the system and its pre-treatment.

2. Install the filter inside the housing or make sure it's inside

the housing.

Recommendations how to insert membranes into the SS housing:

- To insert the membrane in the SS housing it is recommended to remove the cap from the housing, instead of disconnecting all the quick connections and tubing.

- When installing the RO membrane, make sure to look at which direction the arrow is pointing (indicates feed water flow); and where the brine seal will be located.

- When the arrow is pointing up it is recommended to remove both housing caps.

- Then remove the brine seal from the membrane and insert the membrane thru the top of the SS housing (without brine seal).

- Once the membrane reaches the bottom of the housing, re-insert brine seal on to the membrane. And then, when the brine seal is in the correct orientation, slide the membrane up into the housing. Re-install lower and top caps and clamps.

- When installing the membrane with the arrow pointing down, just remove top cap and clamps.

- Slide membrane down until it seats in the lower cap, in this case no need to remove brine seal. Re-install top cap and clamp.

3. Install the membrane(s) in the membrane housing(s). The membrane housings have an arrow indicating the direction of flow. The seal of the membrane should always be installed in the same direction of the water inlet.

(See diagram below, chapter V of this manual).

4. Open the recycling and rejection valves completely.

5. Make all electrical installations including the storage water tank level switch. Make sure the system is connected to an independent designated main breaker.

5 > MEMBRANE INSTALLATION

! > Membrane seal should always be installed in the same direction as the flow of incoming water.

*Note the direction of the membrane seal in the following diagram.

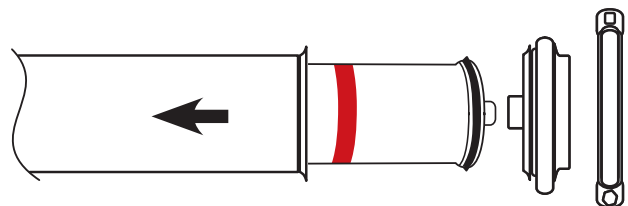

CONTROLLER PROGRAMMING

6 >

PROGRAMMING THE CONTROLLER

NAVIGATION AND PROGRAMMING MENU:

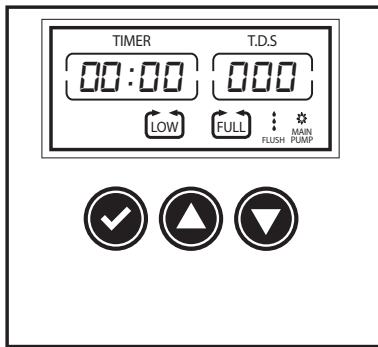

SET key, is access to settings mode



UP key increases the setting values



DOWN key decreases the setting values

Main screen: Displays the operating status:

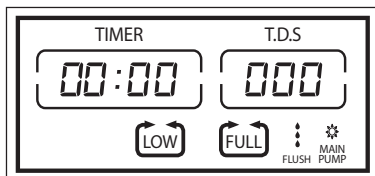

FLUSH (Activated) - Purges at low pressure (*Valid on systems with Fast Flush option*)

LOW - Indicates that the system is protected by low pressure and is off (standby) until there is sufficient inlet pressure to restore system operation.

FULL - Indicates that the system is in standby as the stop signal was received by high product water level in the storage tank.

TIMER - The time the system has been in continuous operation.

! > **PRO+RO SYSTEMS DO NOT KEEP CONTINUOUS TIME IF POWER IS LOST OR IF A LOW PRESSURE OR WATER LEVEL ALERT IS INDICATED AND THE SYSTEM IS SHUT-OFF.**

- At initial start-up, the PRO+RO system counts in seconds until it reaches minutes and later to hours as in the example below.



- When the system reaches 1 hour of continuous operation the system screen counts in hours and minutes as in the example below.



! > **IF POWER IS INTERRUPTED OR IF THE SYSTEM IS SHUT-OFF BY A WARNING SWITCH. THE SYSTEM WILL START FROM ZERO AGAIN.**

TDS - Registers the quality of the product water by measuring the total dissolved solids in PPM units.

By default the controller provides a 10 second delay in start-up of the system when you place the selector switch on **AUTO** for double electrical protection of the system.

CONTROLLER PROGRAMMING:

The PRO+RO Reverse Osmosis System has already been factory programmed with pre-set parameters for basic operation, however if you want to adjust time setting for models purchased with fast integrated flush, then follow these instructions for adjustment:

1. With the system plugged and selector switch off is in **AUTO**, press and hold down the SET key for 3 seconds to enter the settings mode until you hear a "Beep" and enter the options menu to adjust the setting parameters. P1 starts with the UP and DOWN keys to adjust the parameter as you need. Once complete press the SET key again to pass to the next parameter (P2) and so on until you make your adjustments up to P6 and then go back to the home screen.
2. If you purchased a system with membrane fast flush option, you can run the fast flush manually by pressing for 5 seconds the UP and DOWN keys simultaneously and this will be activated for the time you have previously programmed it.
3. Or you can stop the fast flush process and adjust less time while in manual mode by pressing the DOWN button to stop flushing and adjusting less or more time. Hold the DOWN key when you want to return to the original count.

CONTROLLER PROGRAMMING

INFORMATION DISPLAYED ON SCREEN:



Timer - Indicates the time the system has been working and starts measuring a range of time (*minutes:seconds*), after an hour of operation this changes its time reference to: (*hour:minute*).

You can also view here when the membrane is in fast flush mode. It will display a countdown in seconds.

When the system is on (*stand by*) but has the power On- the control will save information showing how long the System has been operating. If for any reason the system does not get an electrical supply the information stored previously will be lost. After 9999 hours, the timer will return to 000 hours.

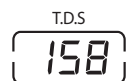

TDS - Shows the quality of product water in TDS PPM being obtained at that time.



LOW : When this appears on the screen, it indicates low pressure in the system. Additionally, on the control box, a Yellow light will illuminate when there is low pressure as a visual reference.



FLUSH - When membrane flush is activated, droplets above the word FLUSH are displayed.



MAIN PUMP - This display represents the high-pressure pump of the System is activated. When Blades are in motion it means the pump is ON. In addition, the green light on the control box will indicate that the system is in operation.



FULL - Appears on the screen when a signal is received that the storage tank is full.

SETTING PARAMETERS:

P1 - Time Setting adjustment for the duration of the membrane fast flush; 15 sec, 30 sec, 45 sec, 60 sec.

P2 - Setting for adjusting the start-up delay time for the start if the system receives any signal by the low pressure or high level switch; 0 sec = off, 5 sec, 10 sec, 15 sec, 20 sec.

P3 - (*OPTIONAL FEATURE – SKIP IF FAST FLUSH WAS NOT PURCHASED WITH THIS FEATURE*) Select frequency or time between each membrane fast flush when the system is operating; 0 = OFF (*OFF function*), 1 hr, 2 hr, 3 hr, 4 hr, 5 hr, 6 hr 7 hr, 8 hr, 9 hr, 10 hr 11 hr 12 hr. (*only used when purchasing a system with fast flush integrated*)

P4 - (*OPTIONAL FEATURE – REQUIRES PROGRAMMING*) Select frequency or time between each membrane flush when the system is in standby; 0 = OFF (*OFF function*), 12 hr, 24 hr, 36 hr, 48 hr, 60 hr, 72 hr, 84 hr, 96 hr.

P5 - TDS range selection (*set point*) if you want to send an alarm signal indicating that water quality has changed; 0 = OFF (*function off*), it can be adjusted 10 PPM to 200 PPM. The control will trigger an alarm indicating that the quality of water changed, then the alarm will repeat every hour, until you identify and correct the problem with the TDS.

P6 - Parameter based on the sensitivity setting of the TDS meter. The lower this parameter the best sensitivity will be for this sensor. It is suggested to be set to less than 15 PPM after calibration.

The last screen in the parameter settings records the last 5 events of "non operation" presented by the system and how long it was off. Up and Down Arrow reads T1, T2, T3, T4 and T5 are records in the memory of the "non operation" and indicates which switch was deactivated.

Parameter settings recommended for basic automation:

P1 = 15 P2 = 0 P3 = 0
P4 = 0 P5 = 50 P6 = 15

CONTROLLER PROGRAMMING

CABLE CONNECTION IDENTIFICATION:

- Violet:** Low level Switch in the raw water tank (SW1) (*)
- Blue:** Shut-Off Switch for the pre-treatment (SW2) (*)
- Green:** Storage tank level switch (FULL)
- Yellow:** Low pressure switch (LOW)
- Gray:** Booster Pump System (FEED)(*)
- Orange:** Solenoid Valve for membrane flush (FLUSH)
- Brown:** High Pressure Pump System
- Red:** Solenoid Valve water feed system
- Black:** Power 110V-240 V

(*) Deactivated in PRO+RO models

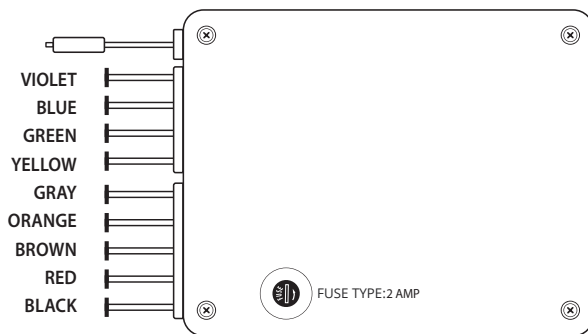

TDS SENSOR CALIBRATION (CONTROLLER):

- The controller has a basic TDS sensor that gives you a reading of the quality of your product water that fills your tank.
- If you want to verify the calibration of the sensor, we recommend calibration solutions in the range of 5 PPM to 10 PPM maximum.
- Turn the selector switch off, remove the sensor from its original position, introduce it into the reference solution and check the reading on the screen. The switch is off, but the controller must be on.
- If there is a difference between what we read on the screen, then press the SET button for 3 seconds and go to parameter P6 and select the value of the reference solution with the UP or DOWN keys and then press SET.
- Reconnect the sensor in its original connection..

CONTROL BOX FEATURES

- Nema 4 Box: ABS
- Electrical Contactor: 24 AMP
- Thermal Relay: 24 AMP
- Low Pressure Switch range: 4-12 PSI
- Selector Switch 2 positions (OFF - AUTO)
- Low pressure indicator light: Yellow LED Type
- Power indicator light: Green LED Type
- Level switch is provided for field installation (in separate bag)
- Power supply options: 120 V (220 V + Neutral on 4SS model)

START-UP

7 > START-UP

1. Make sure that everything related to the pre-treatment process is operating properly and has been backwashed several times to avoid fines from entering the system.
2. Turn the switch on the control box to AUTO. The indicator light on the display lights and the low pressure indicator is activated.
3. All pressure gauges will read 0.
4. Activate the feedwater by opening the supply valve to the system.
5. Make sure the waste and recirculation valve are fully open.
6. The inlet pressure gauge should climb to 30 PSI. When the inlet pressure reaches approximately 20 PSI the low pressure indicator light will turn off.

Note: Ensure all air is purged from system using red pressure relief button button on the top of system.

7. After 10 seconds the pump will come on. After the pump turns on the system pressure gauge will begin to rise.
8. Purge for 10 minutes before adjusting the waste valve by closing it slowly until the product and waste indicator show the same values in GPM.

! > NEVER allow the gauge pressure to exceed 200 PSI.

9. Adjust the waste valve by slowly closing it until the system pressure is in the range of 140-200 PSI depending on the type of membrane used.

! > NEVER completely close the waste valve.

10. The reverse osmosis unit is now in operation. Check for leaks. PPM product water will take approximately 60 minutes to reach the optimum final quality since the membranes must be flushed from preservatives.

! > WARNING: The reverse osmosis system must be flushed thoroughly for one hour before using the product water. The concentrate and permeate should run to a suitable drain for flushing the system.

INITIAL TESTS

After 15-30 minutes both the feedwater and the product water must be monitored with the TDS meter. You must obtain at least 90% rejection in the final product water quality.

If the rejection is less than 90% recheck the installation of the membrane and that they are positioned in the right direction by making sure the seals of the membrane are in the same direction of the flow of water. Also check o-rings and membrane caps to identify where the problem is.

Disconnect the cables from the level switch and make sure that:

1. The system pump turns off automatically.
2. There should be pressure on your pre-filter and remain stable.
3. The pump system is switched off and both the flow to product and waste stop (no output).
4. The control box must remain on and the screen illuminated when the level switch is open, the screen will show full.

Reconnect the wires to the liquid level switch. The pump will automatically turn on. The pressure will increase and the water will flow through the product and rejection.

TROUBLESHOOTING GUIDE

8 > TROUBLESHOOTING GUIDE

Symptom	Possible Cause	Solution
1) The reverse osmosis system will not start.	A) Power switch is off.	A) Place in AUTO position.
	B) No power.	B1) Check power outlet and make sure system is plugged in.
		B2) Check 2AMP fuse on back of controller.
	C) Not enough inlet pressure and the low pressure switch is not activated.	C1) Verify that the feed valve is fully open.
		C2) Make sure your pre-treatment pump is operating properly to supply pressure to the reverse osmosis system.
		C3) Check continuity in the low-pressure switch to ensure it is in good condition and / repair or replace.
		C4) Check that pretreatment does not exceed the pressure drop as this low feed can lead to insufficient water pressure to system.
	D) Timer start is failing in the electronic controller.	D) Check programming boot time.
E) Magnetic starter is burned.	E) Check if overload relay is not under protection. Push black square button at the right of relay to reset. Note: Green LED will be off.	
F) The level Switch is open.	F) Check to see if the storage tank is filled with product water. Lower the level for the switch to close and send the start signal to the system.	
G) Pump motor burned.	G) Check with a multimeter all electrical connections and switches to determine cause of failure before replacing the motor.	
2) No high pressure in the system.	A) Air in the system.	A) It is normal for the system to have and purge air. Let the system run for a while (at least 5 minutes) before starting to adjust the pressure.
	B) Waste Valve open.	B) Adjust the recommended pressure to the membrane type selected.
	C) Recirculation valve completely open.	C) Check and Adjust.
	D) Faulty pressure gauge.	D) Check and Replace.
	E) Tubing or hose kinked or blocked.	E) Check, replace the tubing.
	F) Pump impellers are worn or damaged.	F) Check impellers and replace if necessary.
	G) There is not sufficient water pressure feeding the system and the pump is also sucking and pressurizing at the same time.	G) DANGER! This can collapse pressure tanks on pre-treatment. Check system feed pump as well as its pre-treatment and correct.
	H) Wrong voltage feed.	H1) Make sure the power supply is the voltage that corresponds to your system and make adjustments if necessary.
		H2) Measure motor amperage and verify that it is within the range of motor nameplate for supply voltage. Make adjustments necessary.
I) Clogged or faulty solenoid.	I) Check if your solenoid valve is operating properly And does not have something stuck internally, Check and correct.	
3) No water or too little rejection.	A) Membrane Fouled Open	A) Check the TDS on the product line, if the TDS is the same as the feed water line, the membrane is fouled open or there is a leak of reject water through an oring. Check and if necessary change orings on membrane housing caps or replace the membrane.
	B) Waste valve clogged	B) The pressure exceeds the initial set limit indicating that salts saturation was excessive and is obstructing the waste valve or drain line. Verify that the drain tubing is not bent or kinked, confirm the cause and correct.

TROUBLESHOOTING GUIDE

Symptom	Possible Cause	Solution
4) No product or too little water production.	A) saturated or dirty membrane.	A) Check, clean, replace if necessary.
	B) The water temperature is very low.	B) Check your feed water temperature, check your correction factor for the temperature and make sure that the flow is at an acceptable level.
	C) Low pressure in the system.	C) Check other causes mentioned in this manual under issues of not having enough pressure.
5) Product water with high content of dissolved salts (TDS).	A) Low pressure in the system.	A1) Waste valve open, check and adjust. A2) Check other causes mentioned in this manual under issues of not having enough pressure.
	B) Osmosis membrane seal is not seated or in good condition inside the membrane housing.	B) Check that the membrane is installed properly and for leaks in the oring or cap causing a mixture of water and waste-product.
	C) Reverse osmosis membrane exhausted.	C) The membrane life is on average 2 years. Replace the membrane if life already exhausted.
	D) Product lines and waste water are reversed.	D) Change and correct reversed connections.
	E) The amount of TDS in the feedwater changed.	E) An increase in its raw water TDS can alter product water quality, verify the cause of this increase and that the membrane is rejecting the percentage of suitable salts.
6) Different taste and odor in water product.	A) Saturated and polluted membrane (bacteria).	A) Check, perform chemical cleaning. Replace if necessary.
	B) Presence of foreign matter in the tank storage.	B1) Clean, empty and sanitize the tank.
		B2) Replace filter cartridges.
	C) Product lines and waste water are reversed.	C) Change and correct reversed connections.
	D) Presence of foreign matter in the tank storage.	D) Integrate special pre-treatment to remove gases.
	E) Problems with your pre-treatment.	E1) Exhausted filter media.
		E2) Softener without sufficient rinse time and sends saltwater into the reverse osmosis system. Correct the problem.
	F) Reverse osmosis membrane exhausted.	F) The membrane life is on average 2 years. Replace the membrane if life has been exhausted.
G) Osmosis membrane sealing is not perfect in the membrane housing.	G) Check that the membrane is installed properly and for leaks in the oring or cap causing a mixture of water and waste-product.	
H) Post-carbon filter is exhausted.	H) Replace the Post-carbon filter block if one is installed.	

REVERSE OSMOSIS PRE-TREATMENT

9 > PRE-TREATMENT REQUIRED FOR REVERSE OSMOSIS SYSTEMS.

This flow chart shows the typical pre-treatment and post-treatment equipment to complete the purification process.

For this process to work properly you will need to make the final selection of the most appropriate pretreatment, per the characteristics of incoming water to ensure that your reverse osmosis system will work efficiently. Selection of post-treatment is also recommended to achieve a final quality of water desired.

It is advisable to ensure that raw feed water is microbiologically safe and/or has been subjected to a purification process, if this has not occurred or in doubt, Disinfection should be a considered step by injecting liquid chlorine (preferably) and allowing a contact time of at least 30 minutes. As part of a -primary pretreatment it is recommended that the following be considered in a pretreatment installation:

1. Sediment filter: These filters are designed to remove sediment present in the raw water and are important to prevent dirt from reaching the membrane and fouling it quickly. Various filtering materials such as: multimedia, silica sand, cartridge or bag filters may be used.

2. Activated carbon filter: The membranes (central part) of the reverse osmosis system cannot tolerate chlorine. It is extremely important to give proper maintenance to the unit by changing carbon filter material within recommended time frames, doing this will increase the lifetime of the membranes.

3. Water softener: To avoid saturation and fouling of the membranes a water softener is recommended before reverse osmosis. Depending on the hours of operation of the reverse osmosis system, a simple single tank or dual tank is adequate.

4. Injection anti-incrustate polymer: The intent is to regulate the Ph before entering the osmosis membrane and inhibit the effect of fouling.

TYPICAL REVERSE OSMOSIS PROCESS INSTALLATION

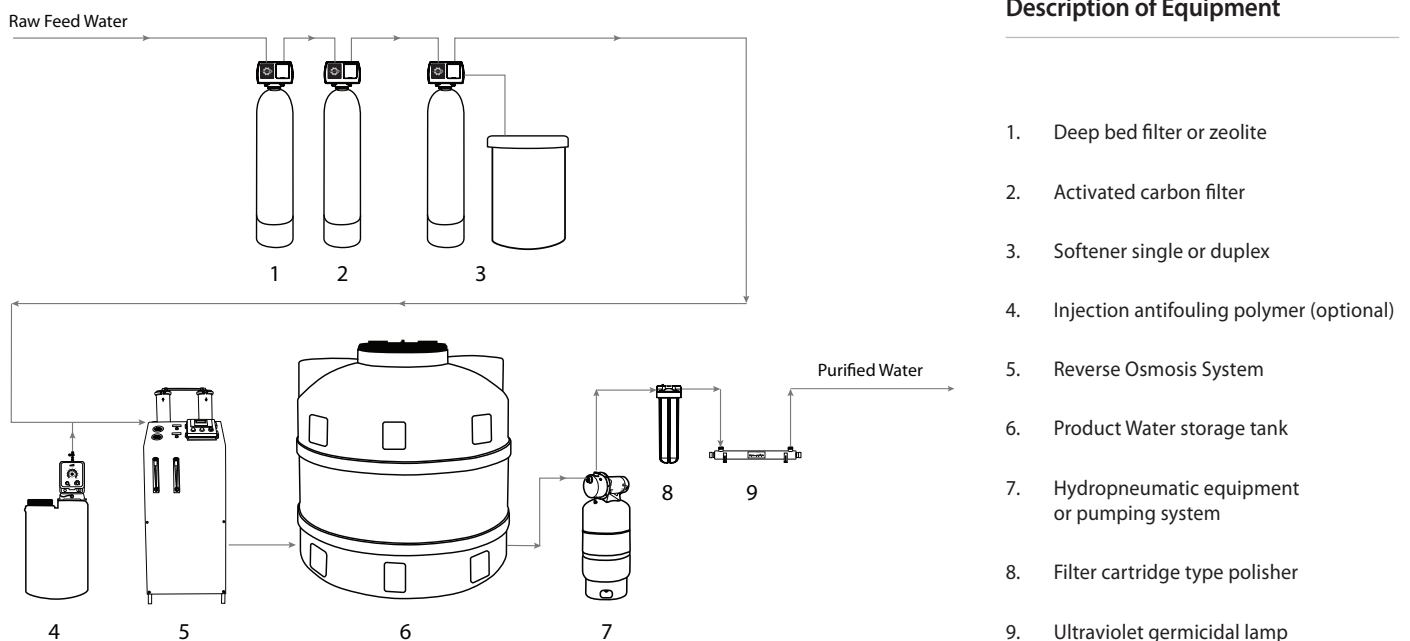

WARRANTY

PRO+AQUA warrants that your new PRO+RO System is built of quality materials and workmanship. When properly installed and maintained, it will give years of trouble free service.

One Year Guarantee

PRO+AQUA will replace any part that fails within (1) one years from date of purchase, provided the failure is due to a defect in material or workmanship. The only exception shall be when proof of purchase and installation is provided. The warranty period shall be from the date of purchase. Parts will not be covered for systems with excessive iron, manganese or with very high chlorine concentrated feed waters. A proper pre-treatment system is required to be placed before the RO system.

PRO+AQUA will provide replacement parts to the original equipment purchaser in possession of a PRO+RO Series RO System that fails within (1) one years after the date of purchase, provided that it is at all times operated in accordance with specifications and not subject to freezing, sunlight or installed outdoors.

General Provisions

PRO+AQUA assumes no responsibility for consequential damage, labor or expense incurred as a result of a defect or for failure to meet the terms of these guarantees because of circumstances beyond our control. Installation workmanship failure is not covered under warranty. Damage caused by environmental conditions such as, lightening strikes, humidity or heat will not be covered under warranty. External uncovered installations are not covered by this warranty. System must be installed in a covered insulated area.

These warranties are in lieu of all other warranties expressed or implied, and we do not authorize any person to assume for us any other obligation on the sale of this water filtration system. No responsibility is assumed for delays or failure to meet these warranties caused by strike, government regulations or other circumstances beyond the control of Pro+Aqua.

Obtaining Warranty Coverage or General Inquiries

If coverage is available, you may obtain coverage under this Limited Product Warranty by providing PRO+AQUA with proof of original purchase, and that you are the original purchaser. In making the claim, please provide the order number, your name, address, phone number, a description of the product involved, an explanation of the defect and photos/video.

SOME STATES DO NOT ALLOW THE EXCLUSION OR LIMITATIONS OF INCIDENTAL OR CONSEQUENTIAL DAMAGES SO THE ABOVE LIMITATION MAY NOT APPLY TO YOU. THIS WARRANTY GIVES YOU SPECIFIC LEGAL RIGHTS, AND YOU MAY ALSO HAVE OTHER RIGHTS WHICH VARY FROM STATE TO STATE. THIS WARRANTY MAY BE TRANSFERRED TO A SUBSEQUENT OWNER WITH WRITTEN APPROVAL FROM PRO+AQUA AND PAYMENT OF STANDARD TRANSFER FEE.

