



Installation Instructions

CR801 Series

Adjustable size 1 to 6

CAUTION

An incorrectly installed or improperly adjusted door closer can cause property damage or personal injury. These instructions should be followed to avoid the possibility of misapplication or misadjustment

| | | |
|--|--|--|
| | <p>Regular Arm Installation closer mounts on hinge (pull) side of door See page 3. closer cover not shown</p> | |
| <p>Left hand door-LH Right hand reverse-RHR</p> | | <p>Right hand door-RH Left hand reverse-LHR</p> |
| | <p>Top Jamb Installation closer mounts on frame face on opposite to hinge (push) side of door See page 4. closer cover not shown</p> | |
| <p>Left hand door-LH Right hand reverse-RHR</p> | | <p>Right hand door-RH Left hand reverse-LHR</p> |
| | <p>Parallel Arm Installation closer mounts on opposite to hinge (push) side of door See page 5. closer cover not shown</p> | |
| <p>Left hand door-LH Right hand reverse-RHR</p> | | <p>Right hand door-RH Left hand reverse-LHR</p> |

Components:

Figure 1

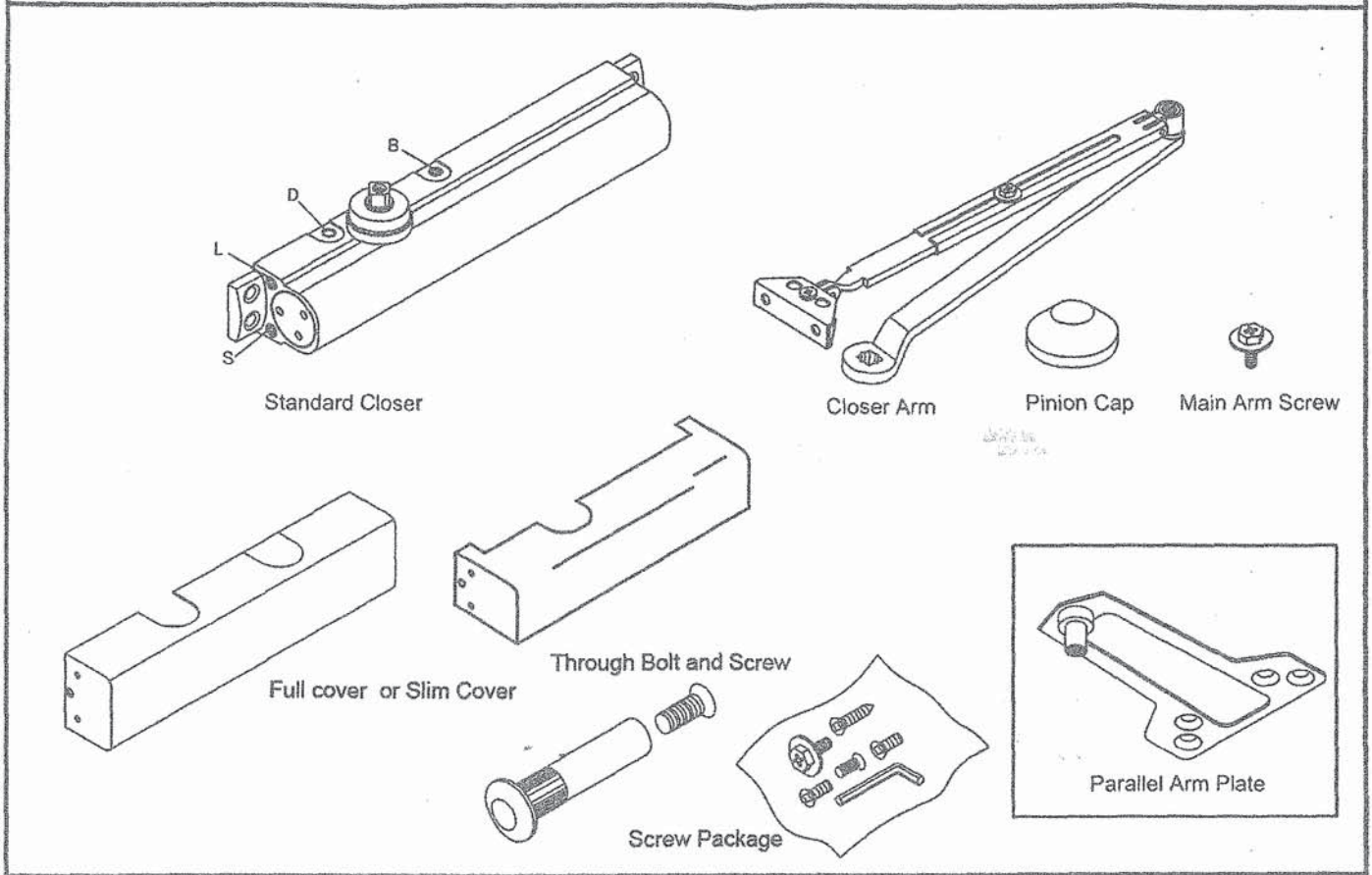

- It is recommended that the door be hung on ball bearing type hinges so door swings freely.
- A separate door stop (supplied by others) is recommended to prevent damage to the door closer, closer arm, or to the door, frame or adjacent walls.
- Door and frame must be properly reinforced or through bolts used to prevent the mounting screws from pulling out.

| Preparation for Fasteners | | |
|--|--------------------------|--|
| Fasteners | Door or Frame | Drill-Sizes |
| Self Drilling/Tapping Machine Screw | Hollow Metal or Aluminum | No drill required |
| | Wood (see note) | 3/16" pilot hole |
| 1/4"-20 Machine Screw | Hollow Metal | Drill #7(0.201" dia.) & Tap 1/4"-20 |
| 1/4"-20 Machine Screw used with Through Bolt | Hollow Metal or Aluminum | 9/32" drill closer side & 3/8" drill opposite side |
| | Wood | |
| Wood Screw | Wood | 3/16" pilot hole |

NOTE: Wood doors/frames must have a pilot hole drilled when using Self Drilling/Tapping screws.

Installation Instructions

Regular Arm Template

Do not scale drawing
Right hand door shown
Dimensions are in inches

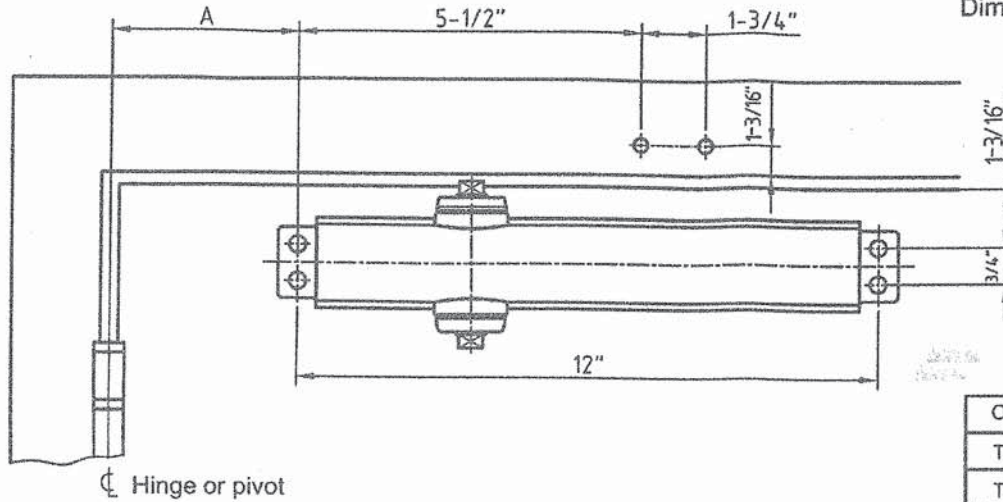

| Opening | Dimension "A" |
|---------|---------------|
| TO 100° | 7-1/2" |
| TO 130° | 6" |
| TO 180° | 4-1/2" |

Installation sequence

- Select degree of opening and use dimensions shown to locate 4 holes on door for closer body and 2 holes on frame face for arm shoe. For application that are different from above, a separate template will be required
- Prepare door and frame for fasteners. See "Preparation for Fasteners", Figure 2, Page 2.
- Before installing closer body....set spring power for closer using Power adjustment chart, below right.
- Install closer on door with speed regulating valves toward the hinge.
- Remove forearm screw from adjusting rod and disassemble arm. See Figure 1, Fasten arm shoe (with rod) to frame face.
- Mount main arm onto closer pinion shaft, aligning arm mark "S" with pinion flat. Secure with main arm screw.
- Reassemble arm. Adjust forearm length so that it will be perpendicular (at a 90° angle) to the door face. Secure with forearm screw.
- Adjust closer (see page 6) and install cover.

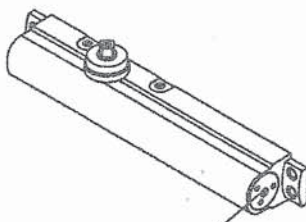
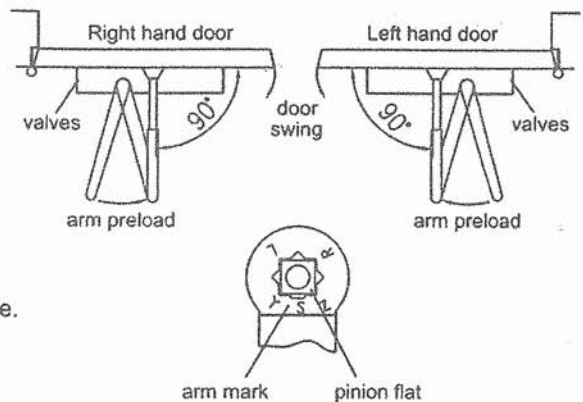

Power Adjustment Nut

 To increase power
Turn clockwise 13 turns maximum

 To decrease power
Turn counterclockwise

Power Adjustment Chart

| door size inches | Full clockwise turns of closer power adjustment nut (from "0" turns) | |
|---------------------|--|---------------|
| | CR 8000 Series | |
| | interior door | exterior door |
| 24"-30" | -7 | -5 |
| 30"-34" | -3 | 0 |
| 34"-38" | 0 | 4 |
| 38"-48" | 4 | 8 |
| 48"-54" | 8 | 13 |
| 54"-60" | 13 | |

NOTE: Maximum of 20 turns (360°) of power adjustment Nut. Closer is shipped set at 7 turns from the factory

Installation Instructions

Top Jamb Template

Do not scale drawing
Right hand door shown
Dimensions are in inches

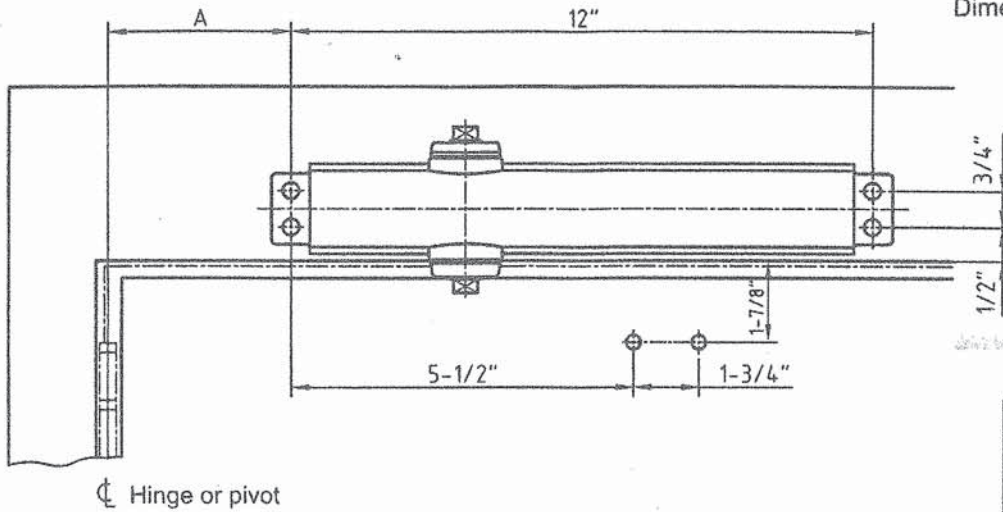

| Opening | Dimension "A" |
|---------|---------------|
| TO 100° | 7-1/2" |
| TO 130° | 6" |
| TO 180° | 4-1/2" |

Installation sequence

- Select degree of opening and use dimensions shown to locate 4 holes on frame face for closer body and 2 holes on door for arm shoe. For application that are different from above, a separate template will be required
- Prepare door and frame for fasteners. See "Preparation for Fasteners", Figure 2, Page 2.
- Before installing closer body....set spring power for closer using Power adjustment chart, below right.
- Install closer on door with speed regulating valves toward the hinge.
- Remove forearm screw from adjusting rod and disassemble arm. See Figure 1, Fasten arm shoe (with rod) to frame face.
- Mount main arm onto closer pinion shaft, aligning arm mark "S" with pinion flat. Secure with main arm screw.
- Reassemble arm. Adjust forearm length so that it will be perpendicular (at a 90° angle) to the door face. Secure with forearm screw.
- Adjust closer (see page 6) and install cover.

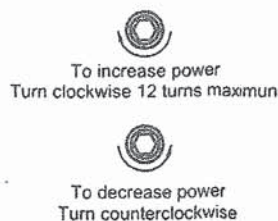
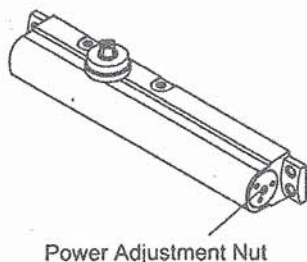
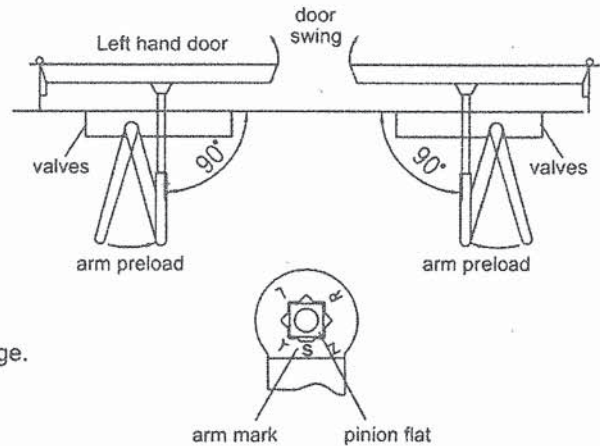

| Power Adjustment Chart | | |
|------------------------|--|---------------|
| door size inches | Full clockwise turns of closer power adjustment nut (from "0" turns) | |
| | CR8000 Series | |
| | interior door | exterior door |
| 24"-30" | -7 | -5 |
| 30"-34" | -3 | 0 |
| 34"-38" | 0 | 4 |
| 38"-48" | 4 | 8 |
| 48"-54" | 8 | 13 |
| 54"-60" | 13 | |

NOTE: Maximum of 20 turns (360°) of power adjustment Nut. Closer is shipped set at 7 turns from the factory

Installation Instructions

Parallel Arm Template

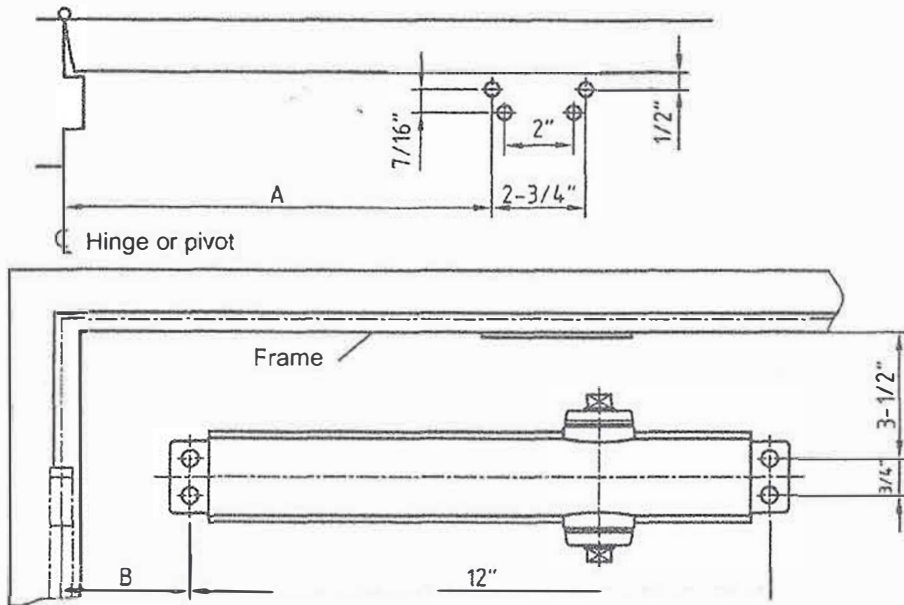

| Opening | Dimension "A" | Dimension "B" |
|---------|---------------|---------------|
| TO 120° | 9-1/2" | 3-3/4" |
| TO 180° | 7" | 1-1/4" |

Dot not scale drawing
Left hand door shown
Dimensions are in inches

Installation sequence

- Select degree of opening and use dimensions shown to locate 4 holes on door for closer body and 4 holes on underside of frame for PA plate. For application that are different from above, a Separate template will be required
- Prepare door and frame for fasteners. See "Preparation for Fasteners", Figure 2, Page 2.
- Before installing closer body....set spring power for closer using Power adjustment chart, below .
- Install closer on door with power adjustment nut toward the hinge.
- Mount soffit plate to frame. Remove forearm screw from adjusting rod (See Figure 1) and attach adjusting rod.
- Install main arm on pinion shaft....see main arm installation instructions below.

- Reassemble arm. Preload is accomplished by adjusting forearm length so that it will set arm elbow about 1-1/2"(38mm) from the door face when connected to the main arm. Secure with forearm screw.
- Adjust closer (see page 6) and install cover.

| Power Adjustment Chart | | |
|------------------------|--|---------------|
| door size inches | Full clockwise turns of closer power adjustment nut (from "0" turns) CR 8000 Series | |
| | interior door | exterior door |
| 24"-30" | -4 | 0 |
| 30"-34" | 0 | 5 |
| 34"-38" | 6 | 10 |
| 38"-48" | 12 | |
| 48"-54" | | |

NOTE: Maximum of 20 turns (360°) of power adjustment Nut. Closer is shipped set at 7 turns from the factory

Main Arm Installation Instructions

Use adjustable wrench to rotate spindle 45° counter-clockwise for right hand door or clockwise for left hand door. Place main arm on spindle so that the "R"(Right hand door) or "L"(Left hand door) lines up with the spindle flat. Secure main arm and spindle by tightening spindle bolt.

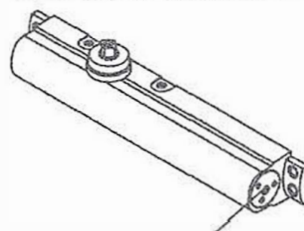

Power Adjustment Nut

To increase power
Turn clockwise 12 turns maximum

To decrease power
Turn counterclockwise

Unit adjustment

Closing speed controls (figure 1,2 and 6)

- Valve "S" controls sweep range
- Valve "L" controls latch range
- Valve "D" controls delayed action range

Opening door control (figure 4 and 5)

- Backcheck ("B") Valve controls the hydraulic resistance to door opening. NEVER close this valve completely- it is not to provide a positive stop

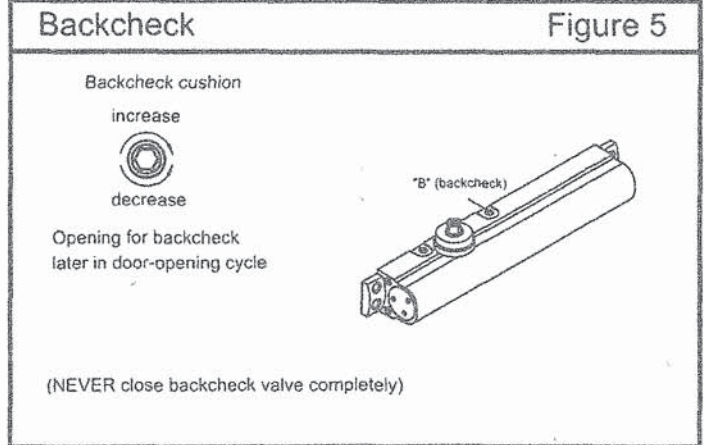
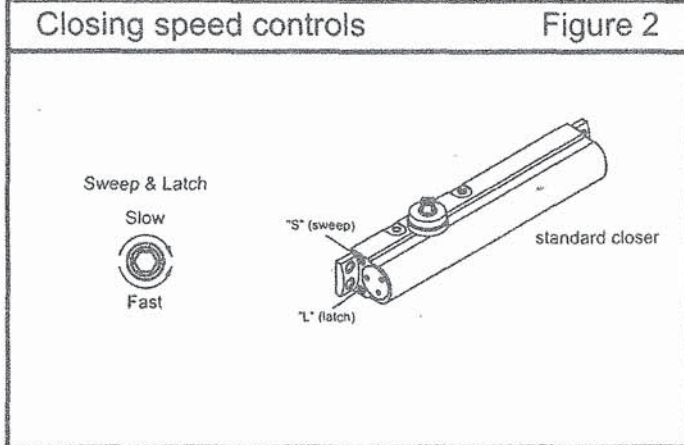
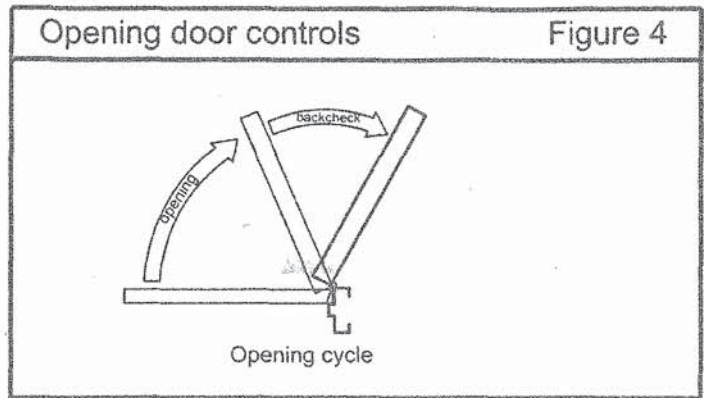
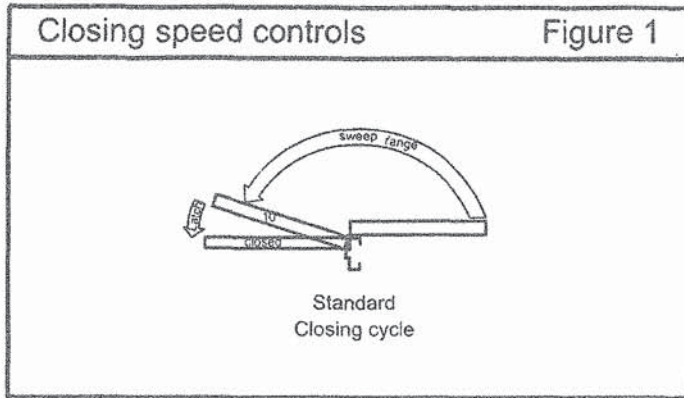

Closing power control (Figure 3)

- Adjust as required (see charts on pages 3, 4, & 5)

Delayed Action Control (Figure 6) (Optional)

