

9202 Edge Pull Installation Guide

1) Prep door according to door prep template on last page.

NOTE: It is recommended that the Edge pull body cut out be centered between the blank plate cut outs.

2) Install the 9202 edge pull using the two (2) #8 x 1" sheet metal screws provided as shown below.

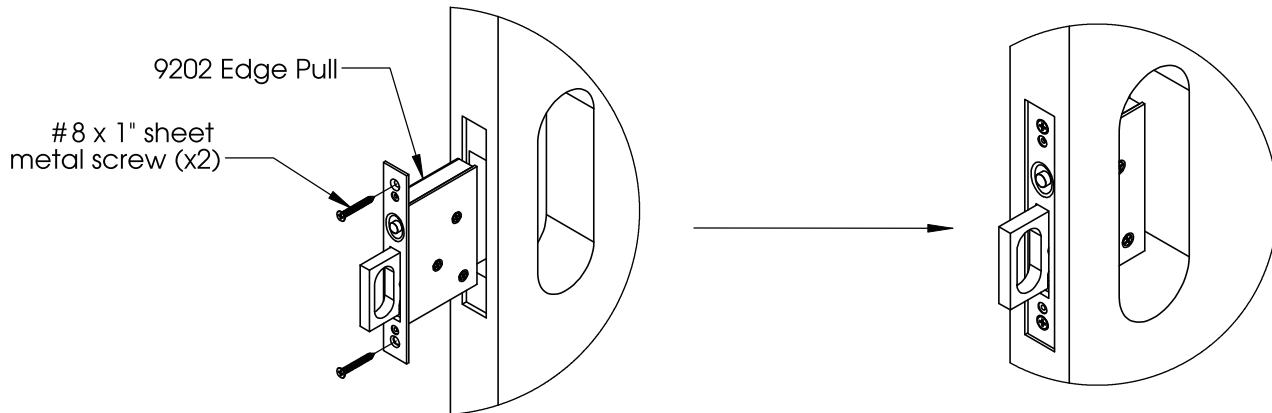

3) Install finished face plate using the two (2) #4 x 3/8" machine screws provided as shown below.

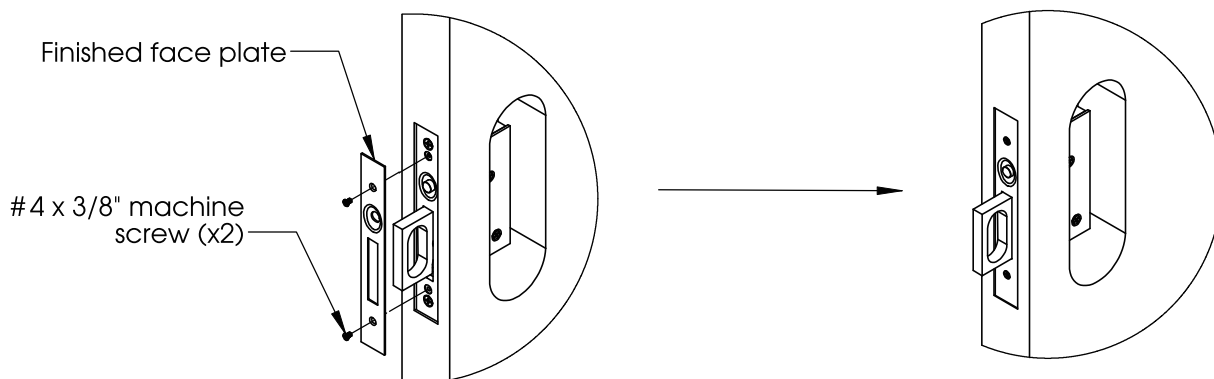

4) Install 82110 blank plates to both sides of the door using the four (4) #6 x 3/4" oval head wood screws provided as shown below.

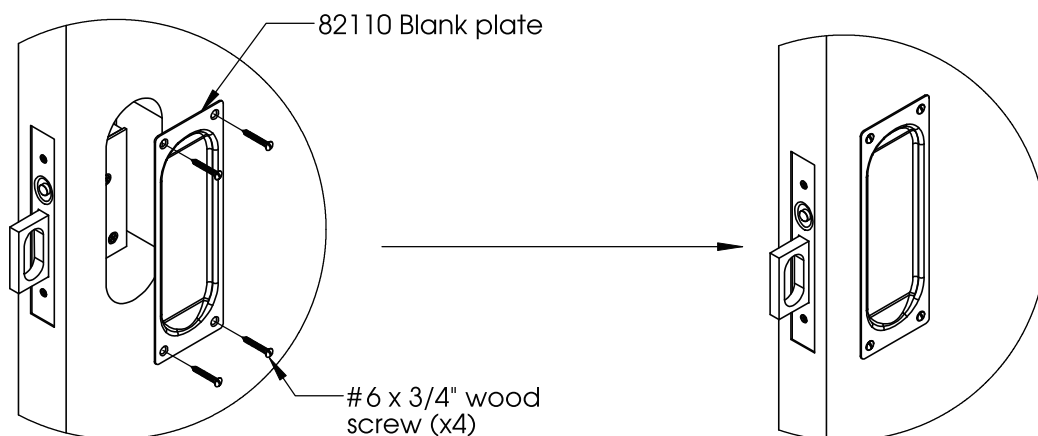

THE INFORMATION CONTAINED IN THIS DRAWING IS THE SOLE PROPERTY OF ERIC MORRIS & COMPANY. ANY REPRODUCTION IN PART OR AS A WHOLE WITHOUT THE WRITTEN PERMISSION OF ERIC MORRIS & COMPANY IS STRICTLY PROHIBITED.

TITLE:

DO NOT SCALE DRAWING

SCALE:1:1

SHEET 1 OF 1



Phone: +1-856-997-0222
Fax: +1-856-294-5116
Email: info@ericmorrisandco.com
Web: <http://www.ericmorrisandco.com>
Address: ERIC MORRIS & COMPANY
7249-A Browning Road
Pennsauken, NJ 08109

9202 Edge Pull Door Prep Template

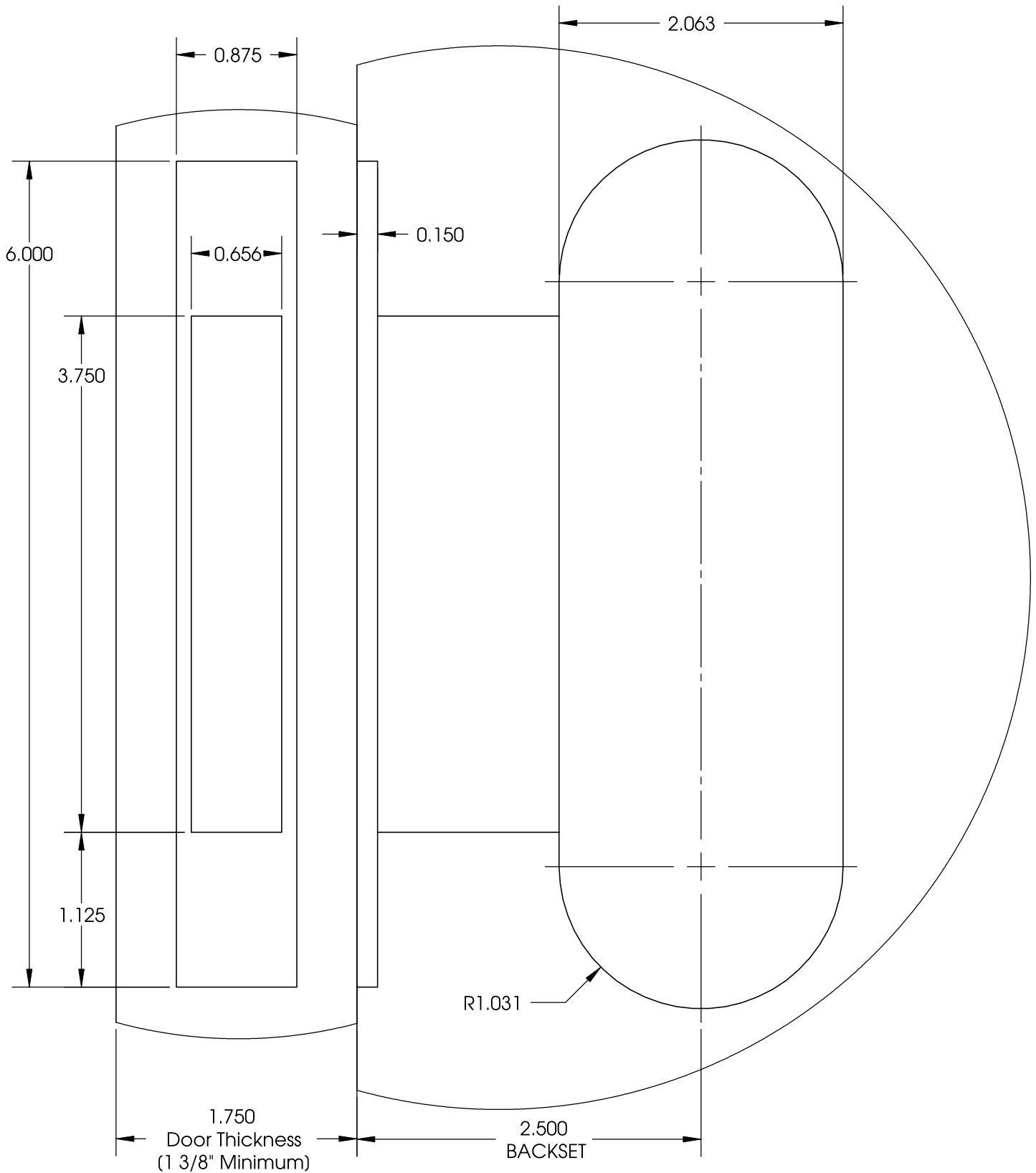

THE INFORMATION CONTAINED IN THIS DRAWING IS THE SOLE PROPERTY OF ERIC MORRIS & COMPANY. ANY REPRODUCTION IN PART OR AS A WHOLE WITHOUT THE WRITTEN PERMISSION OF ERIC MORRIS & COMPANY IS STRICTLY PROHIBITED.

TITLE:

DO NOT SCALE DRAWING

SCALE:1:1

SHEET 1 OF 1



Phone: +1-856-997-0222
 Fax: +1-856-294-5116
 Email: info@ericmorrisandco.com
 Web: <http://www.ericmorrisandco.com>
 Address: ERIC MORRIS & COMPANY
 7249-A Browning Road
 Pennsauken, NJ 08109