



172N

Concealed Fastener TPV Perimeter Seal

PRODUCT CUT SHEET

Material

Aluminum Alloy 6063, T5 Temper
Thermo-Plastic Vulcanizate (TPV)
NGP-TPV is Black

- ▶ Very Good Abrasion Resistance, Tensile Strength and Memory
- ▶ Flame Resistant
- ▶ Moisture Resistant
- ▶ Temperature Range -80°F to 275°F
- ▶ Good Resistance to Ozone, Sunlight and Aging
- ▶ BHMA Certified to ANSI/BHMA A156.22 Performance Tests for Heat and Cold
- ▶ Snap-On Cover Conceals Screw Heads for Clean Appearance
- ▶ #6 X 3/4" Stainless Steel Sheet Metal Screws Furnished
- ▶ Screw Holes Slotted for Adjustment

Finishes

172NA Anodized Aluminum
172NB Gold
172NDKB Dark Bronze

Options

FATT - Fast Attach Tape



PROJECT:
SUBMITTED BY:
DATE:
NOTES:

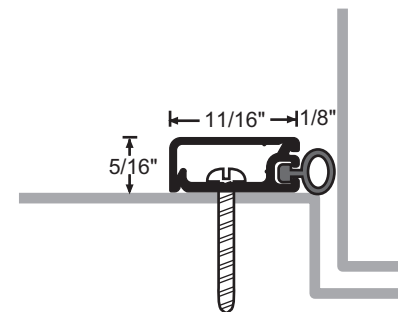
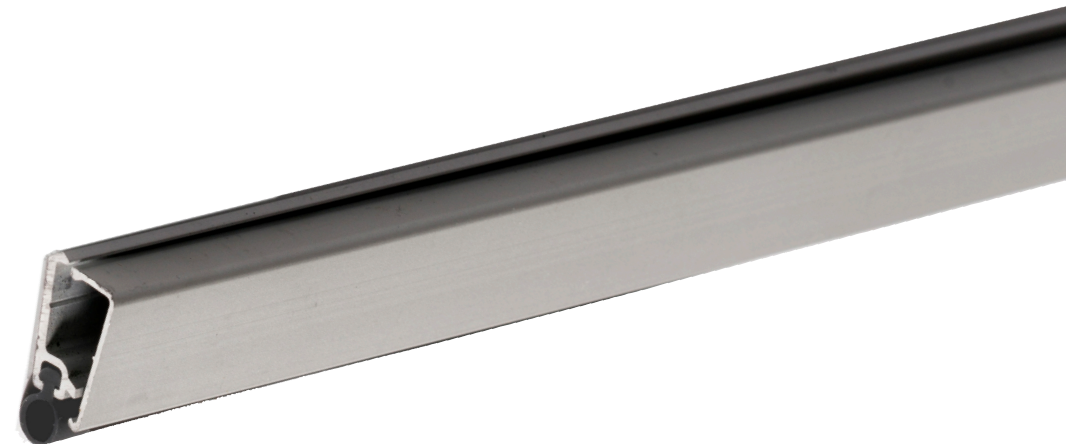

NGP-GKT-172N-PCS-1120-A