

THE HC1 CLASSIC LIGHTWEIGHT & ADVENTURE READY

Happier
Camper



FEATURES & HIGHLIGHTS

Happier Camper's flagship design, the HC1 Classic, was built to be adventure-ready at any moment.

- Designed with an double-hull fiberglass shell, ultralight and maneuverable, towable by most cars
- Built to last for generations to come
- Compact yet sleeps up to 5 with the bunk bed or megabed
- Reinforced dual-hull fiberglass construction
- Get off the grid with solar, off-road tires, and climate control upgrades, such as cooling and heating options
- Enjoy kitchenette, toilet, and shower upgrades
- Modular Adaptiv® system interior is never static – you can easily change up your configuration on the fly
- Fits in a single parking spot

For pricing and upgrades, contact sales@happiercamper.com

BASE SPECIFICATIONS

SLEEPS	UP TO 5
DRY WEIGHT	~1100 LBS
EXTERIOR HEIGHT	7' 8"
EXTERIOR WIDTH	7' 1"
SHELL LENGTH	10' 2"
OVERALL LENGTH	13' 5"
INSIDE WIDTH	6' 2"
INSIDE WIDTH AT BED	6' 10"
INTERIOR HEIGHT	6' 1"
GVWR	UP TO 3500 LBS
WALKABLE FLOOR SPACE	42 SF
REAR HATCH OPENING	54.5" W X 53.5" H

MEASUREMENTS MAY VARY



SIGNATURE REAR HATCH



FULLY MODULAR INTERIOR



KITCHENETTE AND TOILET OPTIONS



SELF-SUSTAINED AND OFF-GRID READY

TECHNICAL SPECIFICATIONS & FLOORPLAN

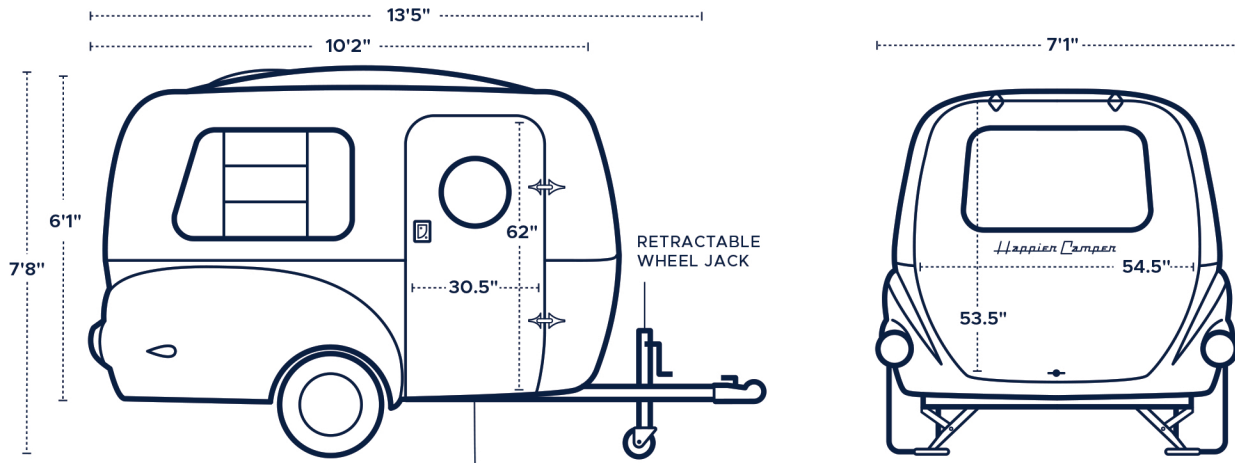

RIGID FRAME W/ TORSION AXLE & GWR OF 3500 LBS.

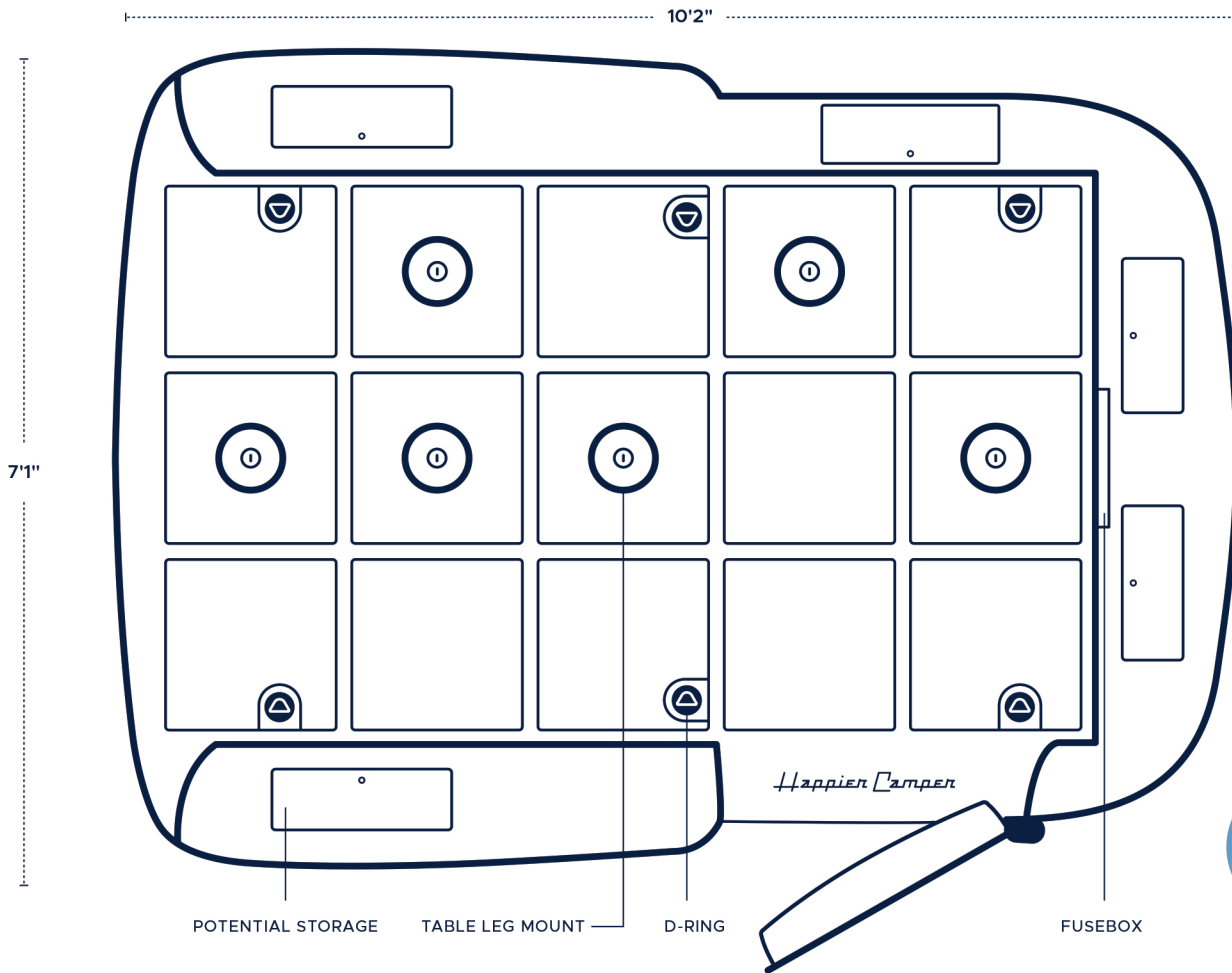

The modular floor of the HC1 is made of 1.5" thick honeycomb fiberglass. It's strong yet incredibly light.

Grooves are embedded in the floor to hold the Adaptiv® cube components in place — just like Lego®.

Table legs easily attach to the floor and are uniquely placed for maximum convenience.