

THE HC1 BREEZE ULTRALIGHT & AFFORDABLE

Happier
Camper



STARTING AT
\$24,950

FEATURES & HIGHLIGHTS

The HC1 Breeze is the latest member of the Happier Camper family. This model is designed & handcrafted thoughtfully to be lighter, simpler and affordable. This trailer shares the core DNA of the flagship HC1, such as the Adaptiv® modular interior, double-hull fiberglass shell, and iconic rear hatch.

- Built to last for generations to come
- Towable by most cars and fits in a single parking spot
- Lightest and most aerodynamic HC1 yet
- Maximum breeze with the sliding windows & rear hatch door
- Modular interior system – never static, reconfigure on the fly
- Compact yet sleeps up to 5 with the bunk bed or megabed
- Enjoy kitchenette and toilet upgrades
- Available in two colors: Mammoth White or Venice Breeze
- Limited customization options available

BASE SPECIFICATIONS

SLEEPS	UP TO 5
DRY WEIGHT	~1100 LBS
EXTERIOR HEIGHT	7' 8"
EXTERIOR WIDTH	7' 1"
SHELL LENGTH	10' 2"
OVERALL LENGTH	13' 5"
INSIDE WIDTH	6' 2"
INSIDE WIDTH AT BED	6' 5"
INTERIOR HEIGHT	6' 1"
GVWR	UP TO 3500 LBS
WALKABLE FLOOR SPACE	42 SF
REAR HATCH OPENING	54.5" W X 53.5" H

MEASUREMENTS MAY VARY



SIGNATURE REAR HATCH



FULLY MODULAR
INTERIOR



KITCHENETTE AND
TOILET OPTIONS



SELF-SUSTAINED AND
ADVENTURE READY

TECHNICAL SPECIFICATIONS & FLOORPLAN

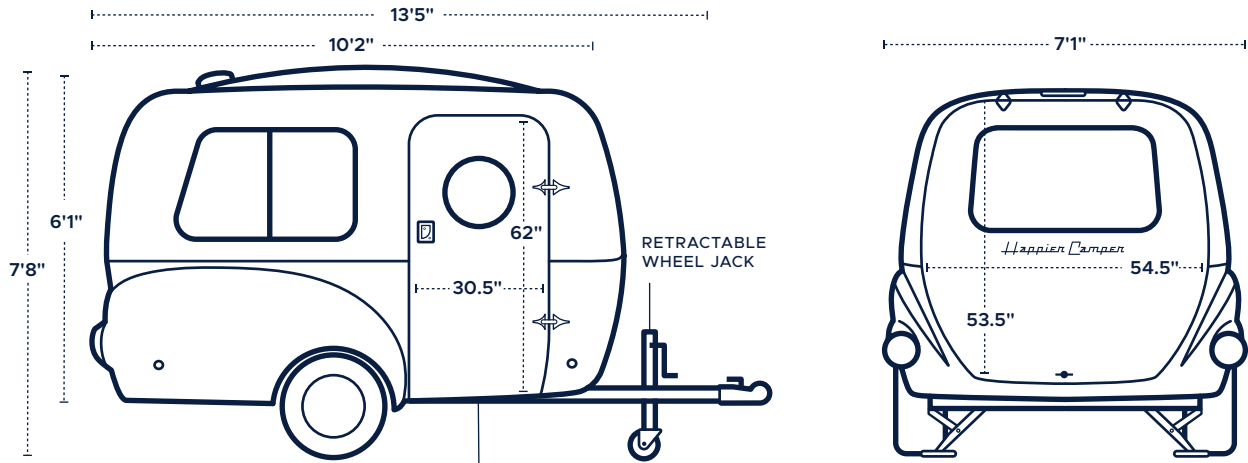

RIGID FRAME W/ TORSION AXLE & GWR OF 3500 LBS.

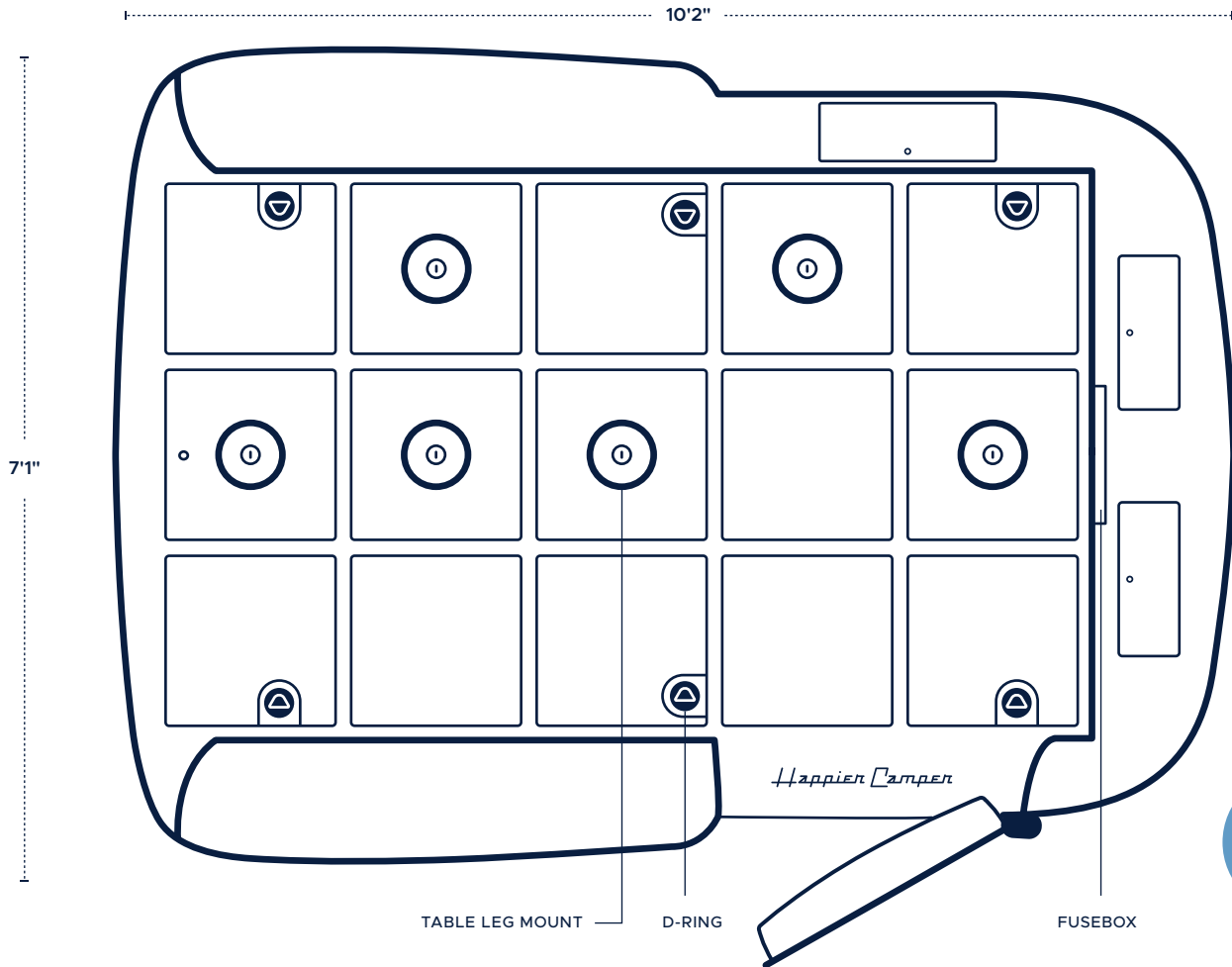

The modular floor of the HC1 is made of 1.5" thick honeycomb fiberglass. It's strong yet incredibly light.

Grooves are embedded in the floor to hold the *Adaptiv*® cube components in place — just like *Lego*®.

Table legs easily attach to the floor and are uniquely placed for maximum convenience.