

TRAVELER

BUILT FOR THE LONG HAUL



FEATURES & HIGHLIGHTS

Hit the road in style and comfort in the Happier Camper Traveler. This fully-equipped trailer is designed to travel anywhere the adventure takes you. Flexible, fun, and built to last for generations.

- Lightest-weight in its class (under 2500 lbs loaded)
- Towable by standard cars and SUV's
- Bathroom equipped with a toilet, shower, and fan
- Well appointed kitchenette with a portable stove, sink, prep space and battery-powered fridge
- Two areas that easily convert from a living space to a queen-sized (front) and full-sized bed (rear) in a snap
- Enjoy the comforts of home indoors and out
- Get off the grid with solar, off-road tires, and heating upgrades

For pricing and upgrades, contact sales@happiercamper.com

BASE SPECIFICATIONS

SLEEPS	4-6 PEOPLE
TONGUE WEIGHT	220 LBS
EXTERIOR HEIGHT	8' 5"
EXTERIOR WIDTH	6' 6"
SHELL LENGTH	13' 2"
OVERALL LENGTH	17'
BATHROOM	2' 11" x 2' 7" x 6' 1"
INSIDE WIDTH AT BED	6' 6"
INTERIOR HEIGHT	6' 5"
GVWR	3500 LBS
PANORAMIC WINDOWS	5

MEASUREMENTS MAY VARY SLIGHTLY



FULLY-FUNCTIONING KITCHENETTE



SHOWER & TOILET FEATURES



SPACIOUS & EFFICIENT DESIGN



ADD BUNK BEDS TO SLEEP MORE

TECHNICAL SPECIFICATIONS & FLOORPLAN

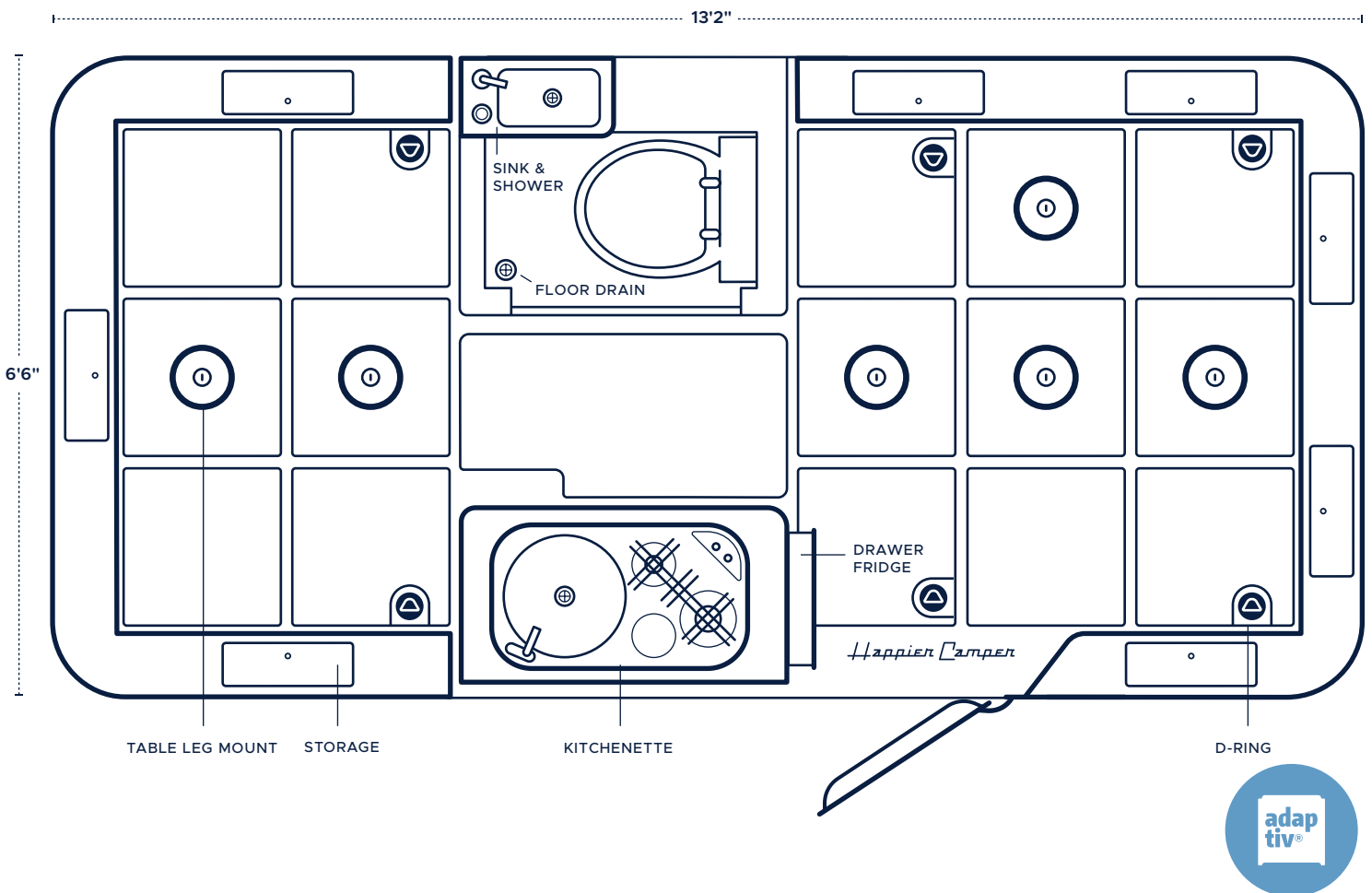
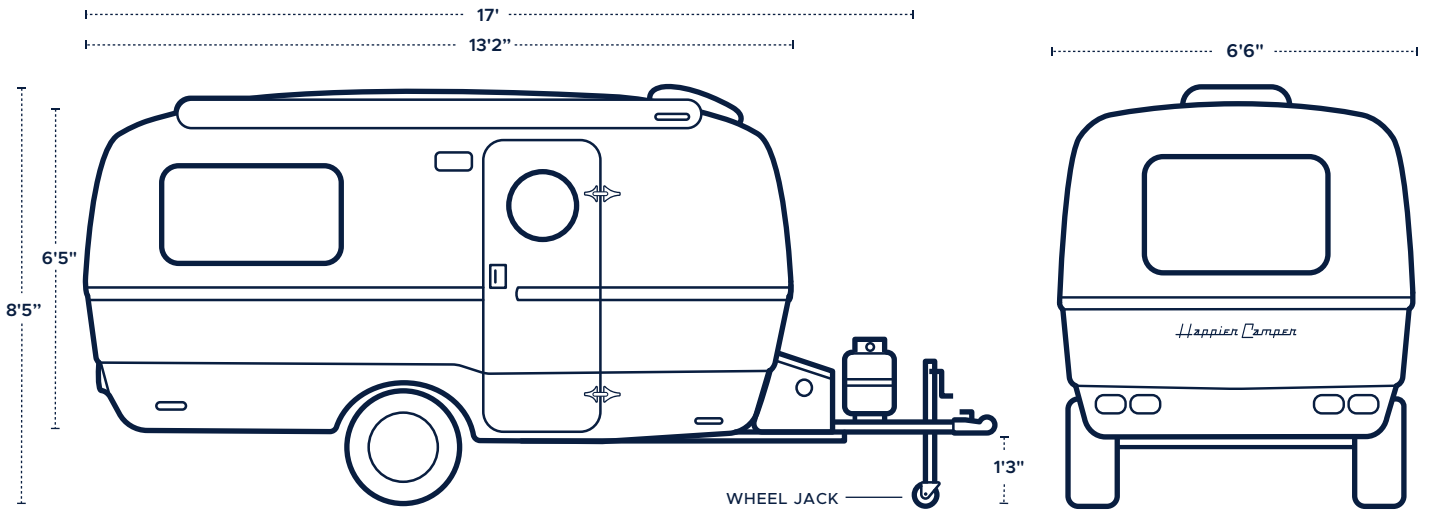

The modular floor of the HCT is made of 1.5" thick honeycomb fiberglass. It's strong yet incredibly light.

Grooves are embedded in the floor to hold the Adaptiv® cube components in place — just like Lego®.

Table legs easily attach to the floor and are uniquely placed for maximum convenience.

