

# Unigestone

5 COLOURS

5 SIZES

3 SURFACES

A collection inspired by the aesthetics of different stones, granites and marbles, skilfully mixed together liven up the style of every environment, whether residential or commercial.

Una collezione ispirata all'estetica di pietre, graniti e marmi differenti sapientemente miscelati tra di loro per muovere con carattere lo stile di ogni ambiente, residenziale o commerciale.

Eine am aussehen verschiedener und auf gelungene Weise miteinander kombinierter Steine, Granite und Marmorarten inspirierte Kollektion. Bringt stilvoll Bewegung und Charakter in jeden Gewerbe- oder Wohnraum.

Une collection qui puise son inspiration a l'esthétique de la pierre. Plusieurs types de granits et de marbres savamment mélangés apportent une note authentique de caractère à tout espace de vie, à usage privatif ou commercial.

## Uniquestone



Spazi Residenziali  
Residential Spaces

P. 5

Spazi Pubblici  
Public Areas

P. 23

Informazioni Tecniche  
Technical Information

P. 39

La superficie della materia è caratterizzata da uno stonalizzo grafico ben bilanciato da un tono di fondo morbido ed omogeneo per un risultato finale molto equilibrato nella sua variabilità. Disponibile in cinque varianti cromatiche in finitura naturale e levigata è ideale per rivestire ambienti interni ed esterni ad alto impatto emozionale.

The material surface is characterized by well-balanced graphic colour and by a soft and uniform colour background for an end result which is very stable in its variability. Available in five different colours in natural and polished finish, it is perfect for covering interior and outdoor environments with high emotional impact.

Die Oberfläche des Materials ist durch grafische Nuancierungen geprägt, die durch eine weiche und gleichmässige Grundnote ausgeglichen werden. Das sorgt für einen trotz der Variabilität harmonischen Gesamteindruck. In fünf Farbvarianten jeweils mit Oberfläche natur und Poliert erhältlich. Ideal zur Verkleidung von Innen- und Außenbereichen von hoher Emotionaler Wirkung.

La surface de la matière est caractérisée par un dénuancement graphique bien équilibré, sur un fond au ton doux et homogène, pour aboutir à une variabilité parfaitement maîtrisée. Disponible en cinq variantes chromatiques, finition naturelle et polie, c'est un revêtement idéal pour l'intérieur et l'extérieur à fort impact émotionnel.

# Spazi Residenziali

Residential Spaces  
Wohnanlagen  
Espaces Résidentiels



COLORI / COLOURS

AMBIENTI / AMBIENT

PAGINA / PAGE

Nite	Bathroom	6
Titanium	Bedroom	10
Sand	Kitchen	14
Silver	Entrance	18
Silk	Living	20

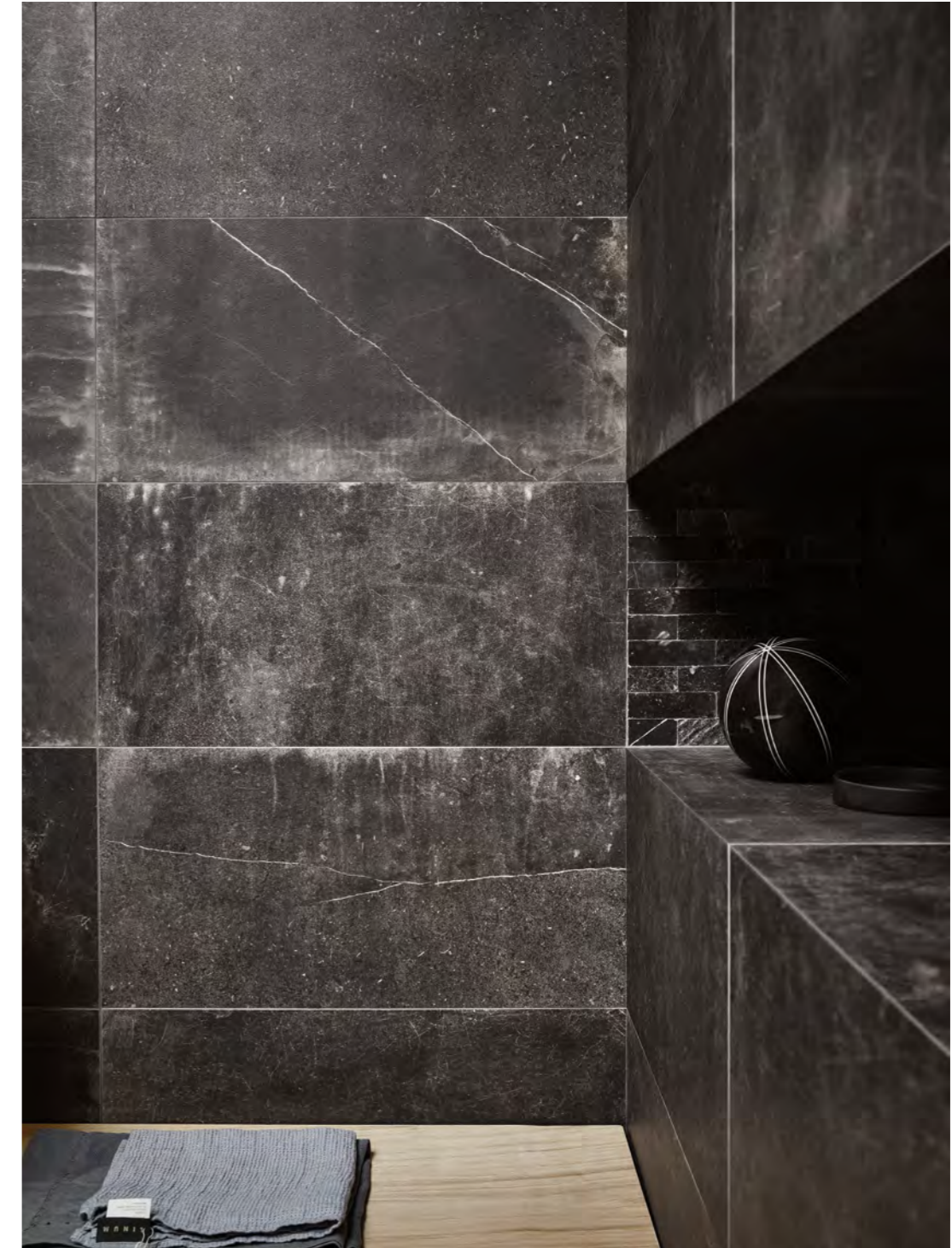



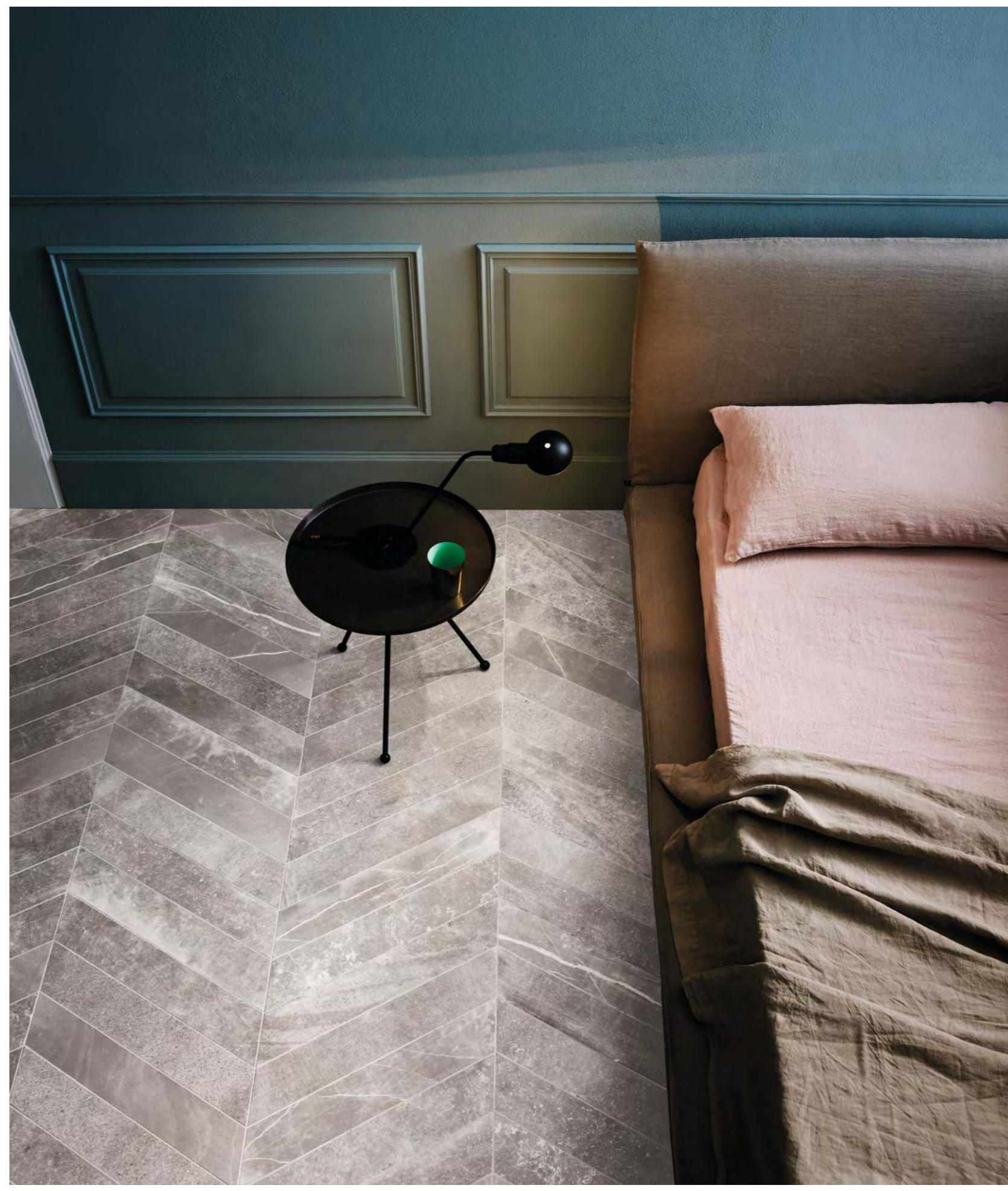









## Silver

The result is a tile which, depending on how it is interpreted, can be used in environments characterised by various styles, from classic to contemporary and eclectic.

Ein Erzeugnis, das je nach Auslegung für verschiedene Stilarten von Klassik bis Modern bis hin zum Eklektizismus geeignet ist.

En fonction de l'interprétation qu'on lui donne, ce produit pourra être décliné sur une grande variété de styles, du classique au contemporain en passant par l'éclectique.

Un prodotto che a seconda dell'interpretazione può essere declinato in varie tipologie di stile, dal classico al contemporaneo, all'eclettico.

30x60 - 12"x24" Naturale Rettificato



Uniquestone  
Residential Spaces



# Spazi Pubblici

Public Areas  
Öffentliche Räumlichkeiten  
Espaces Publics



COLORI / COLOURS

AMBIENTI / AMBIENT

PAGINA / PAGE

Silk	Shop	24
Sand	Hall	28
Silver	Airport Lounge	30
Titanium	Boutique Hotel	34
Nite	Restaurant	36

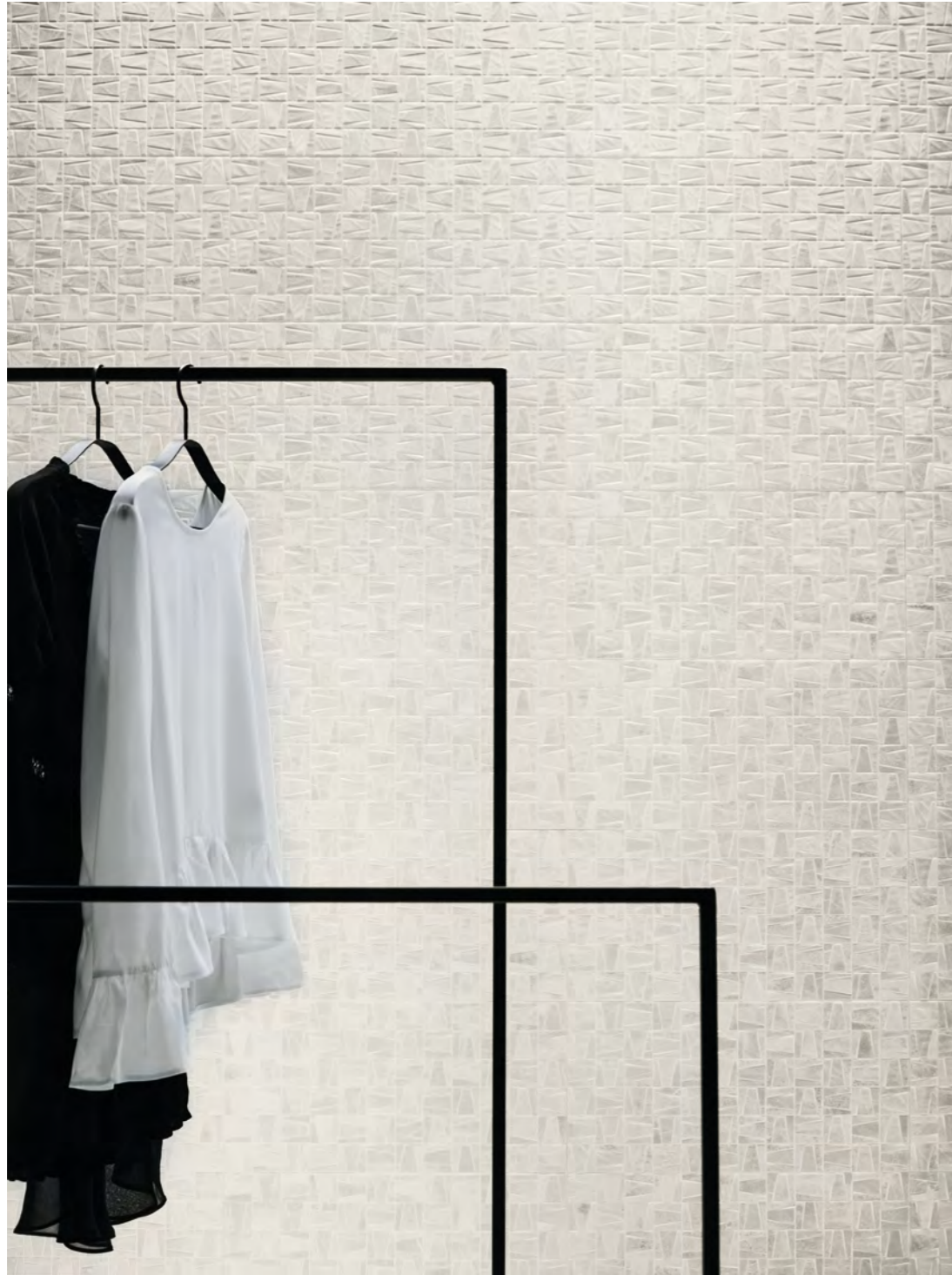



## Sand

It is extremely “transversal”, thanks to its flexibility and the fact that it can be matched and paired with materials of different kinds, “adaptable” due to the possibilities it offers when it comes to interpreting different styles and “versatile” as it can be used to meet a wide variety of design requirements.

Sehr “zweckübergreifend” dank seiner Vielseitigkeit, Kombinationen und Zusammenstellungen mit verschiedenartigen Materialien; “mannigfaltig”, weil es sich mit unterschiedlichen Stilen interpretieren lässt; “vielseitig” für die jeweiligen Entwurfsbedürfnisse.

Sa polyvalence le rend vraiment “transversal”; il peut être associé à des matériaux de nature différente, s’adapte à des styles divers et se plie aux contraintes de la conception.

Altamente “trasversale”, grazie alla sua flessibilità, abbinamenti e accostamenti con materiali di natura differente, “duttile” per la possibilità che offre di interpretazione con stili differenti, “versatile” alle differenti necessità di progettazione.

80×80 - 31½”×31½” Levigato Rettificato









## Titanium

It is an intrinsically sustainable material yet at the same time flaunts a highly sophisticated charm thanks to the technology used to create it.

Das Material ist dank seiner Beschaffenheit nachhaltig und seiner Fertigungstechnologie gleichzeitig auch reich an ausgefeilter Eleganz.

De par sa nature, c'est un matériel écologique qui possède néanmoins un charme très sophistiqué dû à la technologie adoptée pour sa réalisation.

Un materiale sostenibile per la sua stessa natura ed al contempo ricco di un fascino altamente sofisticato grazie alla tecnologia utilizzata per la sua realizzazione.

60x60 - 24"x24" Naturale Rettificato



Uniquestone  
Public Areas

## Nite

Unigestone is the result of ongoing research and experimentation process. This has generated a product that closely resembles the spontaneous, irregular graphic look of the natural materials to which it is inspired.

Unigestone ist das Ergebnis ständiger Recherchen und Versuche, die ein Produkt hervorbrachten, das eine große Ähnlichkeit mit dem spontanen, ungleichmäßigen Aussehen der natürlichen Materialien hat, an denen es inspiriert ist.

Unigestone est le fruit d'une recherche ininterrompue. Celle-ci a donné vie à un produit très proche de la représentation graphique, spontanée et irrégulière, des matériaux naturels dont il s'inspire.

Unigestone è il frutto di una ricerca di continua sperimentazione che ha generato un prodotto molto vicino alla spontanea ed irregolare rappresentazione grafica dei materiali naturali cui si ispira.

80x80 - 31½"x31½" Levigato Rettificato



Unigestone  
Public Areas

# Informazioni Tecniche

## 5

Colori  
Colours  
Farben  
Couleurs

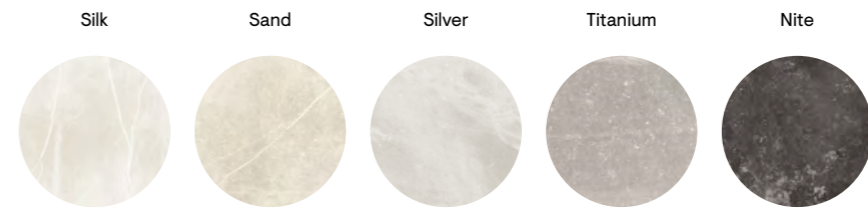

## 5

Formati  
Sizes  
Formate  
Formats

Silk	Sand	Silver	Titanium	Nite
*60×119,5 24"×47½"	80×80 31½"×31½"	60×60 24"×24"	30×60 12"×24"	10×53 4"×20"

## 2

Spessori  
Thickness  
Stärke  
Epaisseur

±9,5      ±10,5

## 3

Superfici  
Surfaces  
Oberflächen  
Surfaces

Naturale      Levigato      Bocciardato

## 4

Strutture 3D  
3D structures  
Strukturen  
Décorations en relief



## i

Effetto Pietra Stone Look Natursteinoptik Effet Pierre	Rivestimento Wall Tiles Wandfliesen Revêtement	Pavimento Floor Tiles Bodenfliesen Sol	Gres fine porcellanato ad impasto colorato Coloured-body fine porcelain stoneware Feinsteinzeug aus farbiger Masse Grès cérame fin à pâte colorée	Tecnologia digitale Digital technology Digital technologie Technologie numérique
---	---	---	--	---

\*Attenzione: verificare in fase di ordine il formato e l'imballo (60×120-60×119,5)

\*Note: In the ordering phase please check size and packaging (60×120-60×119,5)

\*Bitteachten: Beim Bestellen bitte das Format und die Verpackung kontrollieren (60×120-60×119,5)

\*Attention : Merci de vérifier emballage et format au moment de la commande (60×120-60×119,5)

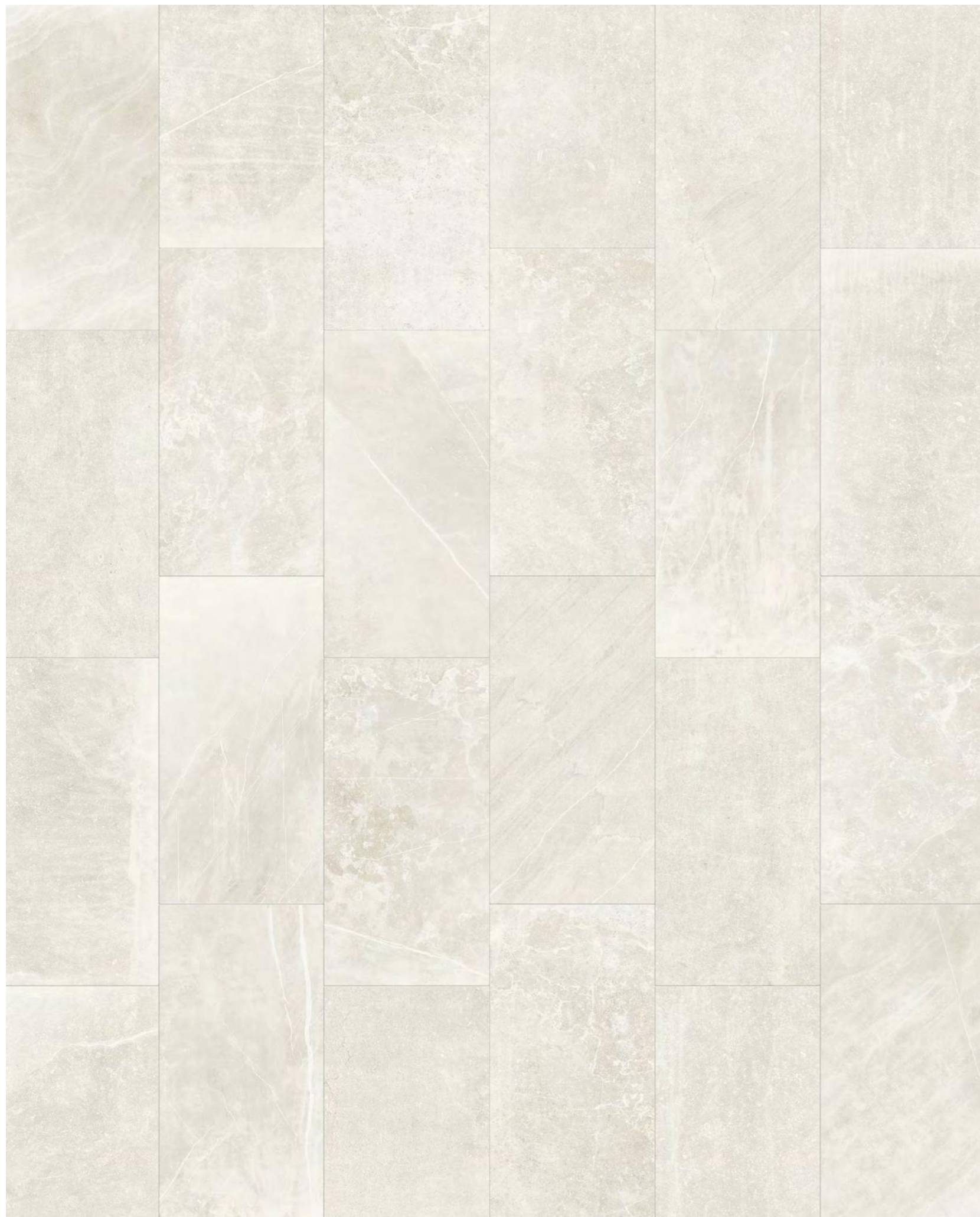

# Silk

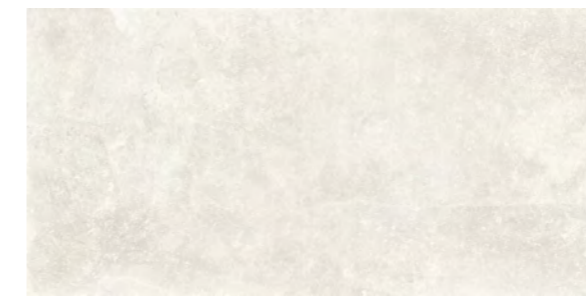

60x119,5 - 24"x47½"  
**02995** | Unique Silk Nat/Ret\* U4 P3 E3 C2  
**02999** | Unique Silk Lev/Ret\*  
**03003** | Unique Silk Bocciardato Ret\*

60x120 - 24"x48"  
**01727** | Unique Silk Bocciardato Ret



60x119,5 - 24"x47½"  
**03008** | Unique Silk Level Ret

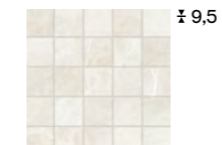

30x30 - 12"x12"  
**01771** | Unique Silk Mosaico Nat/Ret



30x30 - 12"x12"  
**01786** | Unique Silk Mix All In Ret



80x80 - 31½"x31½"  
**01753** | Unique Silk Nat/Ret U4 P3 E3 C2  
**01759** | Unique Silk Lev/Ret



30x60 - 12"x24"  
**01707** | Unique Silk Nat/Ret U4 P3 E3 C2  
**01696** | Unique Silk Lev/Ret

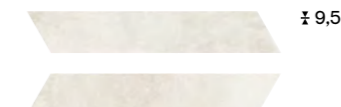

10x53 - 4"x20"  
**01792** | Unique Silk Chevron Nat/Ret U4 P3 E3 C2



30x60 - 12"x24"  
**01785** | Unique Nite Maya Design Ret



60x60 - 24"x24"  
**01702** | Unique Silk Nat/Ret U4 P4 E3 C2  
**01691** | Unique Silk Lev/Ret

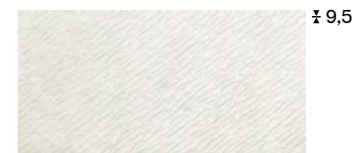

30x60 - 12"x24"  
**01765** | Unique Silk Iced Lev/Ret

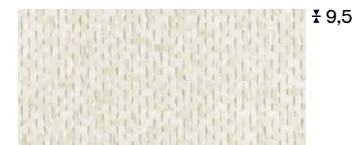

30x60 - 12"x24"  
**01918** | Unique Weave Sk/Sd Nat/Ret



30x60 - 12"x24"  
**01781** | Unique Silk Maya Ret



# Sand

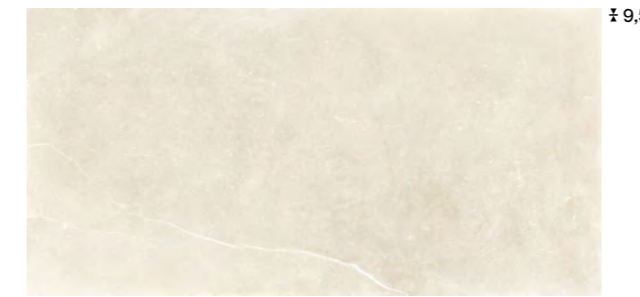

60×119,5 - 24"×47½"  
02996 | Unique Sand Nat/Ret  
03000 | Unique Sand Lev/Ret  
03004 | Unique Sand Bocciardato Ret

U4 P3 E3 C2

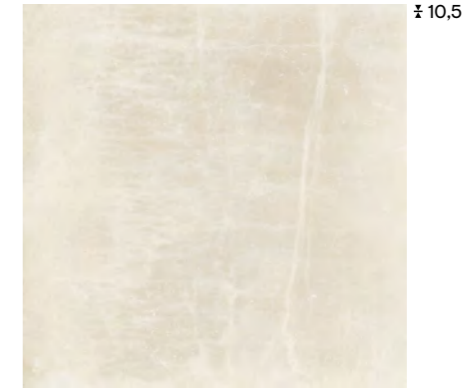

80×80 - 31½"×31½"  
01754 | Unique Sand Nat/Ret  
01761 | Unique Sand Lev/Ret

U4 P3 E3 C2

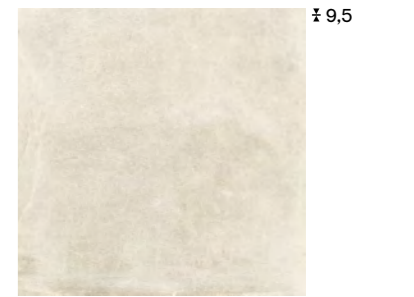

60×60 - 24"×24"  
01703 | Unique Sand Nat/Ret  
01692 | Unique Sand Lev/Ret

U4 P4 E3 C2

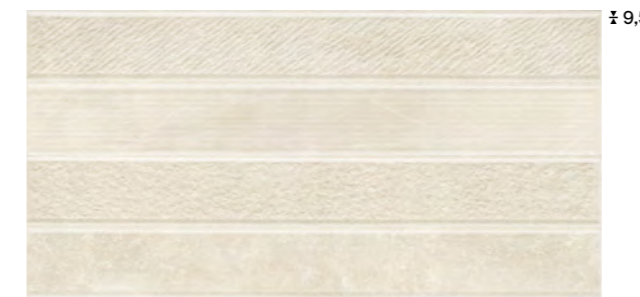

60×119,5 - 24"×47½"  
03009 | Unique Sand Level Ret

9,5

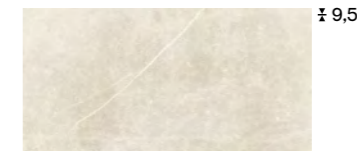

30×60 - 12"×24"  
01708 | Unique Sand Nat/Ret  
01697 | Unique Sand Lev/Ret

9,5

U4 P3 E3 C2

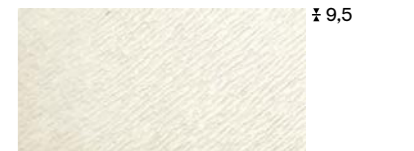

30×60 - 12"×24"  
01766 | Unique Sand Iced Lev/Ret

9,5

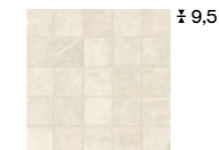

30×30 - 12"×12"  
01772 | Unique Sand Mosaico Nat/Ret

9,5

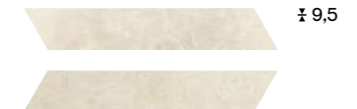

10×53 - 4"×20"  
01793 | Unique Sand Chevron Nat/Ret

9,5

U4 P3 E3 C2

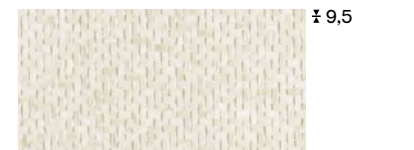

30×60 - 12"×24"  
01918 | Unique Weave Sk/Sd Nat/Ret

9,5



30×30 - 12"×12"  
01787 | Unique Sand Mix All In Ret

9,5



30×60 - 12"×24"  
01782 | Unique Sand Maya Ret

9,5

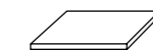
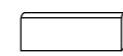



# Silver

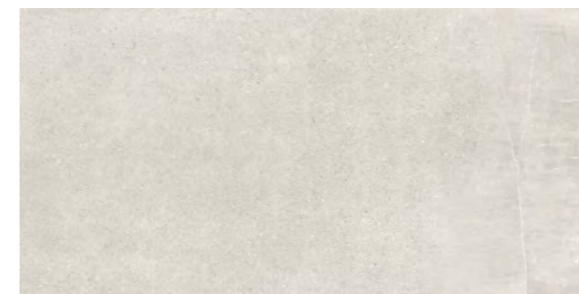

± 9,5\*  
± 10,5

60×119,5 - 24"×47½"

**02997** | Unique Silver Nat/Ret\*  
**03001** | Unique Silver Lev/Ret\*  
**03005** | Unique Silver Bocciardato Ret\*

U4 P3 E3 C2

60×120 - 24"×48"

**01729** | Unique Silver Bocciardato Ret



± 9,5\*  
± 10,5

60×119,5 - 24"×47½"

**03010** | Unique Silver Level Ret\*

60×120 - 24"×48"

**01735** | Unique Silver Level Ret

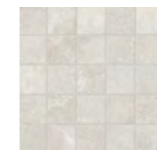

± 9,5

30×30 - 12"×12"

**01773** | Unique Silver Mosaico Nat/Ret



± 9,5

30×30 - 12"×12"

**01788** | Unique Silver Mix All In Ret

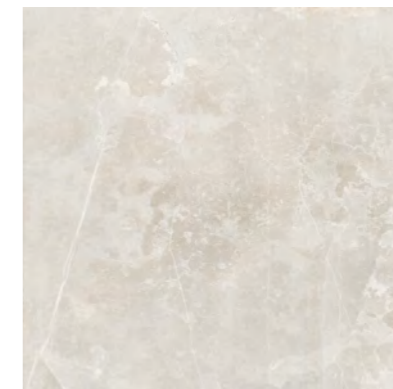

± 10,5

80×80 - 31½"×31½"

**01755** | Unique Silver Nat/Ret  
**01762** | Unique Silver Lev/Ret

U4 P3 E3 C2



± 9,5

60×60 - 24"×24"

**01704** | Unique Silver Nat/Ret  
**01693** | Unique Silver Lev/Ret

U4 P4 E3 C2



± 9,5

30×60 - 12"×24"

**01709** | Unique Silver Nat/Ret  
**01698** | Unique Silver Lev/Ret

U4 P3 E3 C2

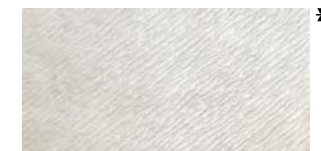

± 9,5

30×60 - 12"×24"

**01767** | Unique Silver Iced Lev/Ret



± 9,5

10×53 - 4"×20"

**01794** | Unique Silver Chevron Nat/Ret

U4 P3 E3 C2



± 9,5

30×60 - 12"×24"

**01917** | Unique Weave Tm/Sr Nat/Ret



± 9,5

30×60 - 12"×24"

**01785** | Unique Nite Maya Design Ret

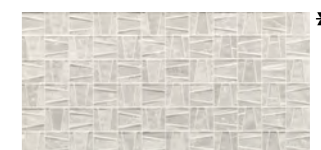

± 9,5

30×60 - 12"×24"

**01783** | Unique Silver Maya Ret

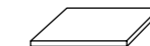
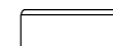





# Titanium

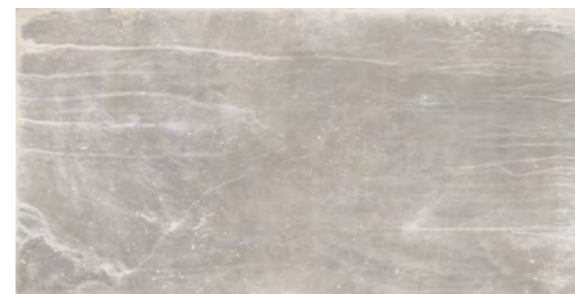

± 9,5\*  
± 10,5

60×119,5 - 24"×47½"

**02976** | Unique Titanium Nat/Ret\*  
**02977** | Unique Titanium Lev/Ret\*  
**03006** | Unique Titanium Bocciardato Ret\*

U4 P3 E3 C2

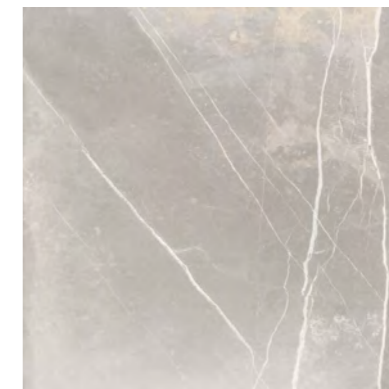

± 10,5

80×80 - 31½"×31½"

**01757** | Unique Titanium Nat/Ret U4 P3 E3 C2  
**01763** | Unique Titanium Lev/Ret



± 9,5

60×60 - 24"×24"

**01705** | Unique Titanium Nat/Ret U4 P4 E3 C2  
**01694** | Unique Titanium Lev/Ret



± 9,5\*  
± 10,5

60×119,5 - 24"×47½"

**03011** | Unique Titanium Level Ret\*

60×120 - 24"×48"

**01725** | Unique Titanium Lev/Ret  
**01731** | Unique Titanium Bocciardato Ret



± 9,5

30×60 - 12"×24"

**01711** | Unique Titanium Nat/Ret U4 P3 E3 C2  
**01699** | Unique Titanium Lev/Ret

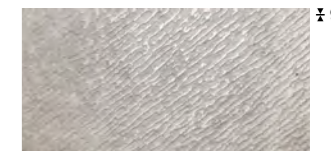

± 9,5

30×60 - 12"×24"

**01768** | Unique Titanium Iced Lev/Ret

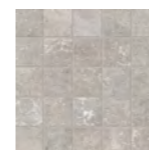

± 9,5

30×30 - 12"×12"

**01774** | Unique Titanium Mosaico Nat/Ret



± 9,5

10×53 - 4"×20"

**01795** | Unique Titanium Chevron Nat/Ret U4 P3 E3 C2



± 9,5

30×60 - 12"×24"

**01917** | Unique Weave Tm/Sr Nat/Ret



± 9,5

30×30 - 12"×12"

**01789** | Unique Titanium Mix All In Ret



± 9,5

30×60 - 12"×24"

**01785** | Unique Nite Maya Design Ret

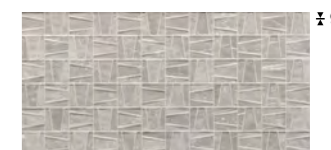

± 9,5

30×60 - 12"×24"

**01784** | Unique Titanium Maya Ret

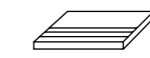
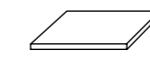
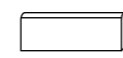



# Nite



± 9,5

60×119,5 - 24"×47½"

02998 | Unique Nite Nat/Ret

03002 | Unique Nite Lev/Ret

03007 | Unique Nite Bocciardato Ret

U4 P3 E3 C2

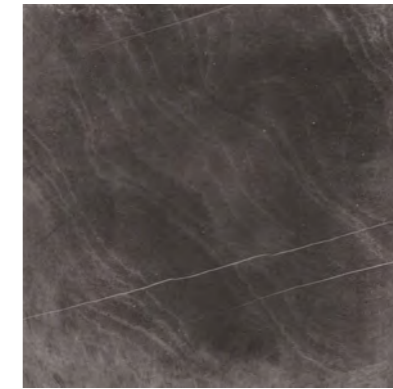

± 10,5

80×80 - 31½"×31½"

01758 | Unique Nite Nat/Ret

01764 | Unique Nite Lev/Ret

U4 P3 E3 C2

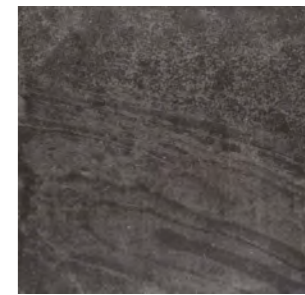

± 9,5

60×60 - 24"×24"

01706 | Unique Nite Nat/Ret

01695 | Unique Nite Lev/Ret

U4 P4 E3 C2

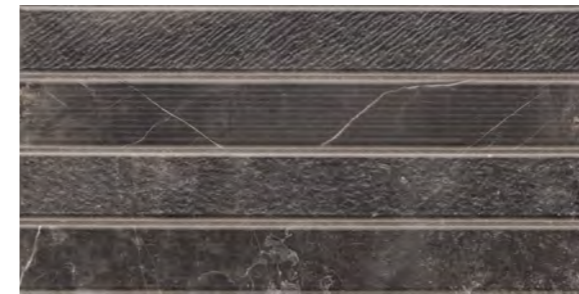

± 9,5

60×119,5 - 24"×47½"

03012 | Unique Nite Level Ret



± 9,5

30×60 - 12"×24"

01712 | Unique Nite Nat/Ret

01701 | Unique Nite Lev/Ret

U4 P3 E3 C2



± 9,5

30×60 - 12"×24"

01769 | Unique Nite Iced Lev/Ret



± 9,5

30×30 - 12"×12"

01775 | Unique Nite Mosaico Nat/Ret



± 9,5

10×53 - 4"×20"

01796 | Unique Nite Chevron Nat/Ret

U4 P3 E3 C2



± 9,5

30×30 - 12"×12"

01791 | Unique Nite Mix All In Ret



± 9,5

30×60 - 12"×24"

01785 | Unique Nite Maya Design Ret

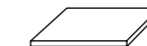
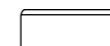

# Fasce di Prezzo

Price range  
Preisgruppe  
Niveau de prix

■ Fascia prezzo al metro quadro  
Square meter price range  
Quadratmeter preisgruppe  
Niveau de prix au mètre carré

▲ Fascia prezzo al pezzo  
Price range per piece  
Stück preisgruppe  
Niveau de prix à la piece

Formati Sizes										Strutture 3D 3D Structures												
	*60x120 24"x48"	*60x119,5 24"x47½"	80x80 - 31½"x31½"	60x60 - 24"x24"	30x60 - 12"x24"	Chevron 10x53 - 4"x20"	DIN 51130	DIN 51097	DCOF	Level *60x120 24"x48"	Level *60x119,5 24"x47½"	Maya 30x60 12"x24"	Iced 30x60 12"x24"	Weave 30x60 12"x24"								
	± 10,5	± 9,5	± 10,5	± 9,5	± 9,5	± 9,5				± 10,5	± 9,5	± 9,5	± 9,5	± 9,5								
Silk	Nat/Ret	02995	740	01753	740	01702	550	01707	500	01792	820				03008	790	01781	560		01918	560	
	Lev/Ret	02999	790	01759	770	01691	680	01696	650											01765	700	
	Bocciardato	01727 03003	750																			
Sand	Nat/Ret	02996	740	01754	740	01703	550	01708	500	01793	820				03009	790	01782	560		01918	560	
	Lev/Ret	03000	790	01761	770	01692	680	01697	650											01766	700	
	Bocciardato	03004	750																			
Silver	Nat/Ret	02997	740	01755	740	01704	550	01709	500	01794	820				01735 03010	790	01783	560		01917	560	
	Lev/Ret	03301	790	01762	770	01693	680	01698	650											01767	700	
	Bocciardato	01729 03005	750																			
Titanium	Nat/Ret	02976	740	01757	740	01705	550	01711	500	01795	820				01739 03011	790	01784	560		01917	560	
	Lev/Ret	01725 02977	790	01763	770	01694	680	01699	650											01768	700	
	Bocciardato	01731 03006	750																			
Nite	Nat/Ret	02998	740	01758	740	01706	550	01712	500	01796	820				03012	790	01785	560				
	Lev/Ret	03002	790	01764	770	01695	680	01701	650											01769	700	
	Bocciardato	03307	750																			

\*Attenzione: verificare in fase di ordine il formato e l'imballo (60x120-60x119,5)  
 \*Note: In the ordering phase please check size and packaging (60x120-60x119,5)  
 \*Bitteachten: Beim Bestellen bitte das Format und die Verpackung kontrollieren (60x120-60x119,5)  
 \*Attention : Merci de vérifier emballage et format au moment de la commande (60x120-60x119,5)

# Fasce di Prezzo

Price range  
Preisgruppe  
Niveau de prix

■ Fascia prezzo al metro quadro  
Square meter price range  
Quadratmeter preisgruppe  
Niveau de prix au mètre carré

▲ Fascia prezzo al pezzo  
Price range per piece  
Stück preisgruppe  
Niveau de prix à la piece

Formati Sizes			Pezzi Speciali Special Pieces												
	Mosaico 30x30 - 12"x12"	Mosaico Mix All In 30x30 - 12"x12"	Gradino 30x120 - 12"x48"	Gradino 30x60 - 12"x24"	Battiscopa 6,5x120 - 2½"x48"	Battiscopa 8x80 - 3¼"x31½"	Battiscopa 8x60 - 3¼"x24"								
	± 9,5	± 9,5	± 10,5	± 9,5	± 10,5	± 10,5	± 9,5								
Silk	Nat/Ret	01771	▲160			01831	▲710	01836	▲200	01797	▲130	01808	▲100	01819	▲60
	Lev/Ret									01803	▲170	01814	▲140	01825	▲130
Sand	Nat/Ret	01772	▲160			01832	▲710	01837	▲200	01798	▲130	01809	▲100	01821	▲60
	Lev/Ret									01804	▲170	01815	▲140	01826	▲130
Silver	Nat/Ret	01773	▲160			01833	▲710	01838	▲200	01799	▲130	01811	▲100	01822	▲60
	Lev/Ret									01805	▲170	01816	▲140	01827	▲130
Titanium	Nat/Ret	01774	▲160			01834	▲710	01839	▲200	01801	▲130	01812	▲100	01823	▲60
	Lev/Ret									01806	▲170	01817	▲140	01828	▲130
Nite	Nat/Ret	01775	▲160			01835	▲710	01841	▲200	01802	▲130	01813	▲100	01824	▲60
	Lev/Ret									01807	▲170	01818	▲140	01829	▲130

# Imballi

Packing  
Verpackung  
Emballage

Formati Sizes		± MM	Pezzi Scatola Pieces/Box Stck/Karton Carreaux/Boîte	Mq/Scatola Sqmt/Box Qm/Karton M2/Boîte	Kg/Scatola Kgs/Box Kg/Karton Kg/Boîte	Scatole/Paletta Boxes/Pallet Karton/Palette Boîte/Palette	Mq/Paletta Sqmt/Pallet Qm/Pallet M2/Palette	Kg/Paletta Kgs/Pallet Kg/Pallet Kg/Palette	Formato Paletta Size Pallet Format Pallet Dim. Palette
*60*120 (24"*48") Nat/Ret - Lev/Ret	P	10,5	2	1,440	34,00	27	38,88	918	120*80*75
*60*119,5 (24"*47¼") Nat/Ret	P	9,5	2	1,434	31,00	30	43,02	930	120*80*75
*60*119,5 (24"*47¼") Lev/Ret	P	9,5	2	1,434	32,00	30	43,02	960	120*80*75
*60*120 (24"*48") Bocciardato Ret - Level Ret	P	10,5	2	1,440	34,00	27	38,88	918	120*80*75
*60*119,5 (24"*47¼") Bocciardato Ret - Level Ret	P	9,5	2	1,434	31,00	30	43,02	930	120*80*75
80*80 (31½"*31½") Nat/Ret	P	10,5	2	1,280	31,50	40	51,20	1260	120*80*97
80*80 (31½"*31½") Lev/Ret	P	10,5	2	1,280	31,50	40	51,20	1260	120*80*97
60*60 (24"*24") Nat/Ret	P	9,5	3	1,080	21,50	40	43,20	860	120*80*75
60*60 (24"*24") Lev/Ret	P	9,5	3	1,080	22,50	40	43,20	900	120*80*75
30*60 (12"*24") Nat/Ret	P	9,5	6	1,080	21,50	48	51,84	1032	120*80*75
30*60 (12"*24") Lev/Ret	P	9,5	6	1,080	22,50	48	51,84	1080	120*80*75
30*60 (12"*24") Maya Ret	P	9,5	6	1,080	21,50	40	43,20	860	120*80*75
30*60 (12"*24") Iced Lev/Ret	P	9,5	6	1,080	21,50	40	43,20	860	120*80*75
30*60 (12"*24") Weave Nat/Ret	P	9,5	6	1,080	21,50	40	43,20	860	120*80*75
10*53 (4"*20") Chevron Nat/Ret	P	9,5	12	0,636	13,20	60	38,16	792	120*80*75
30*30 (12"*12") Mosaico Nat/Ret	P	9,5	5	0,450	8,50	60	-	-	-
Pezzi Speciali / Special Pieces									
30*60 (12"*24") Gradino Nat/Ret	P	9,5	6	1,080	21,50	36	-	-	-
30*120 (12"*48") Gradino Nat/Ret	P	10,5	3	1,080	25,00	20	-	-	-
8*60 (3¼"*24") Battiscopa Nat/Ret	P	9,5	10	0,480	11,00	72	-	-	-
8*60 (3¼"*24") Battiscopa Lev/Ret	P	9,5	10	0,480	11,00	72	-	-	-
8*80 (3¼"*31½") Battiscopa Nat/Ret	P	10,5	7	0,450	11,00	65	-	-	-
8*80 (3¼"*31½") Battiscopa Lev/Ret	P	10,5	7	0,450	11,00	65	-	-	-
6,5*120 (2½"*48") Battiscopa Nat/Ret - Lev/Ret	P	10,5	8	0,624	14,00	48	-	-	-

\*Attenzione: verificare in fase di ordine il formato e l'imballo (60\*120-60\*119,5)  
\*Note: In the ordering phase please check size and packaging (60\*120-60\*119,5)  
\*Bitteachten: Beim Bestellen bitte das Format und die Verpackung kontrollieren (60\*120-60\*119,5)  
\*Attention : Merci de vérifier emballage et format au moment de la commande (60\*120-60\*119,5)

# Pezzi Speciali

Special pieces  
Formstücke  
Pièces spéciales

Battiscopa Nat/Ret 8\*60 - 3¼"\*24" ± 9,5  
Battiscopa Lev/Ret 8\*60 - 3¼"\*24" ± 9,5

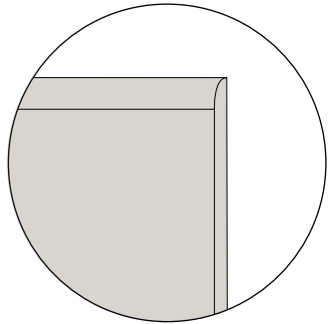
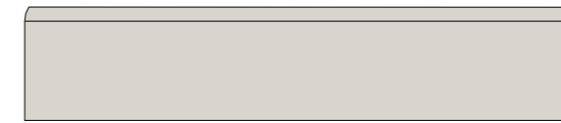

Battiscopa Nat/Ret 8\*80 - 3¼"\*31½" ± 10,5  
Battiscopa Lev/Ret 8\*80 - 3¼"\*31½" ± 10,5

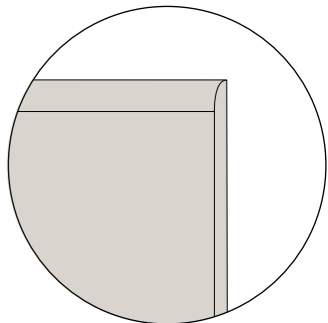
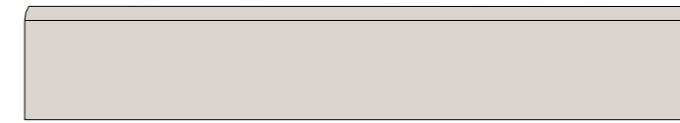

Battiscopa Nat/Ret 6,5\*120 - 2½"\*48" ± 10,5  
Battiscopa Lev/Ret 6,5\*120 - 2½"\*48" ± 10,5

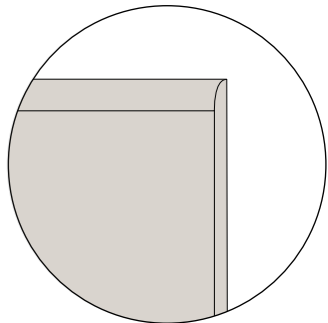
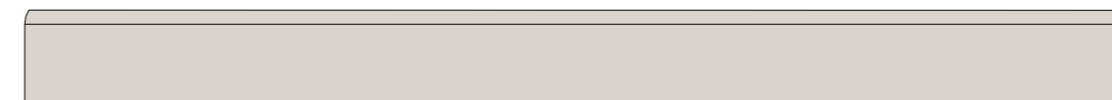

Gradino Nat/Ret 30\*60 - 12"\*24" ± 9,5  
(Becco civetta e fresature tecniche - bullnose edge with grooves)

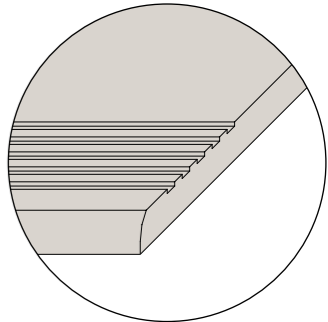

Gradino Nat/Ret 30\*120 - 12"\*48" ± 10,5  
(becco civetta tecnico - bullnose edge)

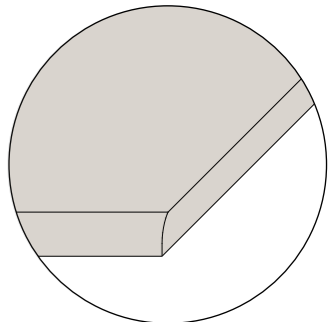

# Caratteristiche Tecniche

Technical characteristics  
Technische daten  
Caracteristiques techniques

CLASSIFICAZIONE SECONDO NORME CEN/ISO GRUPPO B1A EN 14411 - ISO 13006 - CLASSIFICATION IN ACCORDANCE WITH CEN/ISO STANDARDS B1A EN 14411 - ISO 13006  
KLASSIFIZIERUNG GEMÄSS CEN/ISO-NORMEN GRUPPE B1A EN 14411 - ISO 13006 - CLASSIFICATION SELON LES NORMES CEN/ISO GROUPE B1A EN 14411 - ISO 13006

CARATTERISTICA TECNICA TECHNICAL CHARACTERISTIC TECHNISCHE DATE CARACTÉRISTIQUE TECHNIQUE	NORMA NORM NORME	VALORE PRESCRITTO VALUE REQUIRED NORMVORGABE VALEUR PRESCRIPTE	VALORE MEDIO MEAN VALUE MITTELWERT VALEUR MOYENNE CERAMICHE PIEMME FLOOR AND MORE	USA TESTS 	VALORE MEDIO MEAN VALUE MITTELWERT VALEUR MOYENNE CERAMICHE PIEMME FLOOR AND MORE
LUNGHEZZA E LARGHEZZA LENGHT AND WIDTH / LÄNGE UND BREITE / LONGUEUR ET LARGEUR		±0,6% (±2,00 MM)			
SPESORE THICKNESS / STÄRKE / EPAISSEUR		±5% (±0,5 MM)			
RETILINEITÀ LATI WARPAGES OF EDGES / GERADHEIT DER KANTEN / RÉCITITUDE DES ARÊTES	ISO 10545.2	±0,5% (±15 MM)	CONFORME IN ACCORDANCE ERFÜLLT CONFORME	ASTM C-499 ASTM C-485 ASTM C-502	IN ACCORDANCE
ORTOGONALITÀ WEDGING / RECHTWINKLIGKEIT / ORTHOGONALITÉ		±0,5% (±2,00 MM)			
PLANARITÀ FLATNESS / PLANITÄT / PLANIMÉTRIE		±0,5% (±2,00 MM)			
ASSORBIMENTO % D'ACQUA WATER ABSORPTION WASSERANNAHME % ABSORPTION D'EAU %	ISO 10545.3	≤ 0,5%	CONFORME IN ACCORDANCE ERFÜLLT CONFORME	ASTM C-373	IN ACCORDANCE
RESISTENZA ALLA FLESSIONE BENDING STRENGTH BIEGEZUGFESTIGKEIT RÉSISTANCE À LA FLEXION	ISO 10545.4	≥ 35N/MM <sup>2</sup>	CONFORME IN ACCORDANCE ERFÜLLT CONFORME	ASTM C-648 250 LBS OR GREATER	IN ACCORDANCE
DILATAZIONE TERMICA LINEARE TRA 20° E 100° C LINEAR THERMAL EXPANSION BETWEEN 20° AND 100° C LINEARE WÄRMEAUDEHNUNG ZWISCHEN 20° UND 100° C DILATATION THERMIQUE LINÉAIRE ENTRE 20° ET 100° C	ISO 10545.8	SECONDO I DATI DEL COSTRUTTORE ACCORDING TO BUILDER'S SPECIFICATIONS LAUT ANGABEN DES HERSTELLERS SELON LES ÉLÉMENTS DU CONSTRUCTEUR	≈ 7X10 <sup>-6</sup> C <sup>-1</sup>		
RESISTENZA AGLI SBALZI TERMICI THERMAL SHOCK RESISTANCE TEMPERATURWECHSELBESTÄNDIGKEIT RÉSISTANCE AUX ÉCARTS DE TEMPÉRATURE	ISO 10545.9	RICHIESTA REQUEST BITTE DEMANDE	RESISTENTE RESISTANT WIDERSTEHEND RÉSISTANT		
RESISTENZA AL GELO FROST RESISTANCE FROSTBESTÄNDIGKEIT RÉSISTANCE AU GEL	ISO 10545.12	RICHIESTA REQUEST BITTE DEMANDE	RESISTENTE RESISTANT WIDERSTEHEND RÉSISTANT	ASTM C-1026	IN ACCORDANCE
RESISTENZA ALL'ATTACCO CHIMICO RESISTANCE TO CHEMICAL ATTACK BESTÄNDIGKEIT GEGEN CHEMIKALIEN RÉSISTANCE À L'ATTAQUE CHIMIQUE	ISO 10545.13	SECONDO I DATI DEL COSTRUTTORE ACCORDING TO BUILDER'S SPECIFICATIONS LAUT ANGABEN DES HERSTELLERS SELON LES ÉLÉMENTS DU CONSTRUCTEUR	RESISTENTE RESISTANT WIDERSTEHEND RÉSISTANT	ASTM C-650	IN ACCORDANCE
RESISTENZA DEI COLORI ALLA LUCE COLOURS RESISTANCE TO LIGHT LICHTBESTÄNDIGKEIT RÉSISTANCE DES COULEURS À LA LUMIÈRE	DIN 51094	NESSUNA ALTERAZIONE NO ALTERATION KEINE VERÄNDERUNG AUCUNE ALTERATION	CONFORME IN ACCORDANCE ERFÜLLT CONFORME		
RESISTENZA ALLE MACCHIE STAIN RESISTANCE FLECKENFESTIGKEIT RÉSISTANCE AUX TACHES	ISO 10545.14	≥ CLASSE 3 METODO DI PROVA DISPONIBILE TEST METHOD AVAILABLE VERFÜGBARE PRÜFMETHODE METHODE D'ESSAI DISPONIBLE	CONFORME IN ACCORDANCE ERFÜLLT CONFORME		
RESISTENZA ALLO SCIVOLAMENTO SLIPPAGE RESISTANCE RUTSCHSICHERHEIT RÉSISTANCE AU GLISSEMENT	DIN 51130 *	9 ≤ R ≤ 13	NAT LEV BOCCIARDATO	ASTM C-1028 * COF ≥ 0,6 DRY ≥ 0,6 WET	NAT LEV BOCCIARDATO
	DIN 51097 *	A,B,C	NAT LEV BOCCIARDATO	ANSI * 137,1-2012 DCOF > 0,42 WET	NAT LEV BOCCIARDATO > 0,42
PENDULUM SLIP TEST	BS EN 7976-2*	> 36 DRY > 36 WET	NAT LEV BOCCIARDATO		NAT LEV BOCCIARDATO

\*Trattandosi di normative nazionali, i metodi di prova, i requisiti e le classificazioni variano da paese a paese. Il valore atteso dalla resistenza allo scivolamento della produzione di Industrie Ceramiche Piemme S.p.a. può variare in base al lotto produttivo. Specifica documentazione è disponibile su richiesta. ELENCO DELLE SERIE CERTIFICATE E CLASSIFICAZIONI DISPONIBILI A RICHIESTA. Test methods, requirements and classifications differ from country to country, according to the national regulations. The expected value of slippage resistance of products by Industrie Ceramiche Piemme S.p.a. may vary depending on the production batch. Specific documents are available upon request. LIST OF CERTIFIED SERIES AND CLASSIFICATIONS AVAILABLE UPON REQUEST. Prüfverfahren, Erfordernisse und Klassifikationen sind verschieden von Land zu Land, gemäß der nationalen Vorschriften. Der Erwartungswert der Rutschsicherheit der Produkte von Industrie Ceramiche Piemme S.p.a. kann sich - je nach der Produktionspartie - verändern. Spezifische Unterlagen sind auf Verlangen zur Verfügung. LISTE DER GEPRÜFTEN SERIE UND KLASSIFIZIERUNGEN AUF ANFRAGE ERHÄLTICH. Les méthodes d'essai, les réquisitions et les classifications changent de pays à pays, selon les réglementations nationales. La valeur attendue de résistance au glissement des produits de Industrie Ceramiche Piemme S.p.a. peut varier en fonction du lot de production. Une documentation spécifique est disponible sur demande. LISTE DES SERIES CERTIFIÉES ET DES CLASSEMENTS DISPONIBLES SUR DEMANDE.

CONCERNANT LA NORME UPEC, VEUILLEZ SVP VERIFIER DIRECTEMENT SUR INTERNET EN TAPANT "UPEC PIEMME" LES REFERENCES ET/OU FINITIONS EVENTUELLEMENT PAS ENCORE A CE JOUR CERTIFIEES.



CERAMICHE PIEMME  
FLOOR AND MORE



# Norme per la posa e la manutenzione

Installation and maintenance instructions  
Verlegung, reiningung und pflege  
Guide a la pose et l'entretien

- Per i prodotti rettificati consigliamo una fuga di 2 mm per un migliore risultato di posa.
- Per una migliore resa estetica Piemme consiglia stuccature colorate in tinta con le piastrelle. Verificare, prima dell'utilizzo, la compatibilità ed idoneità dei riempitivi per fughe con il prodotto ceramico.
- Rimuovere le eccedenze dei riempitivi per fughe quando gli stessi sono ancora freschi.
- Attenersi scrupolosamente alle istruzioni indicate dai produttori dei riempitivi per fughe.
- Per eliminare completamente i residui di posa, che potrebbero compromettere la manutenzione ordinaria e le caratteristiche del prodotto, a posa ultimata, procedere con la pulizia utilizzando prodotti adeguati, a base Acida max 3%, rispettando le indicazioni del produttore. Osservare assolutamente i limiti di tempo indicati nelle istruzioni: un contatto troppo prolungato con questi prodotti potrebbe provocare il danneggiamento della superficie.
- Gli eventuali aloni che si dovessero presentare dopo la posa di materiali lappati o levigati si potranno facilmente eliminare utilizzando un prodotto idoneo, a base Alcalina.

- For better installation results of rectified products, we suggest 2 mm joint.
- For a better aesthetic finish, Piemme recommends using jointing colours that match the tiles.
- Please check, before using, the compatibility and suitability of grouting material with the ceramic tile.
- Clean away the excess of grouting materials while they are still fresh.
- Follow carefully the instructions pointed out by the producers of tile grouting materials.
- To completely eliminate installation residues, which could negatively affect routine maintenance and product characteristics once installation has terminated, proceed to clean using adequate products, with max. 3% Acid base, following the manufacturer's instructions. Always closely abide by the time limits indicated in the instructions: prolonged contact with these products may cause damage to the surface.
- Any rims that appear after installing lapped or polished materials can be easily eliminated using a suitable Alkaline-based product.
- With regard to the use of ceramic materials outdoors, while once more reiterating that Piemme porcelain stoneware products are frost-proof, in compliance with applicable European standards EN 14411/ISO 13006-ISO 10545.12, a number of fundamental procedures must be followed for outdoor installation, suitable for making the aforementioned floors resistant to frost. The most important aspects are: suitable gradients, waterproofing, expansion joints, and the use of suitable installation materials.
- Decorations made with glazes and precious metals It is most important to protect the surface during installation. Never use abrasive and/or acid products, only water and neutral soap. The manufacturer disclaims liability in case of any damage to these precious materials caused by "rubbing" during installation. Under no circumstances will disputes be accepted relating to the installed material.

- Damit sich eine bessere Verlegung von geschliffenen Produkten ergibt, empfehlen wir eine Fugenbreite von 2 mm. Für ein optisch perfektes Ergebnis empfiehlt Piemme, die Fugen farblich auf die Fliesen abzustimmen.
- Prüfen sie bitte, vor der Verwendung, die Zweckmäßigkeit und die Verträglichkeit des Fugenfüllmittels mit den Keramikfliesen.
- Bitte entfernen sie das überflüssige Fugenfüllmittel wenn es noch frisch ist.
- Folgen sie bitte sorgfältig die von dem Herstellern des Fugenfüllmittels angegebenen Bedienungsvorschriften.
- Zur vollkommenen Entfernung der Verlegerückstände, die die normale Pflege erschweren und die Merkmale des Produkts beeinträchtigen könnten, nach der Verlegung geeignete Reinigungsmittel auf max. 3% Säurebasis verwenden und bei der Reinigung die Hinweise des Herstellers beachten. Die angegebenen Zeiten keinesfalls überschreiten: ein zu lange andauernder Kontakt mit diesen Produkten kann Beschädigungen der Oberfläche verursachen.
- Eventuelle nach der Verlegung von geläpftem oder geschliffenem Material sichtbare Schleier lassen sich einfach mit entsprechenden, alkalischen Produkten entfernen.
- Auch wenn die Piemme-Feinsteinzeugprodukte gemäß den europäischen Normen EN 14411/ISO 13006-ISO 10545.12 frostbeständig sind, müssen beim Einsatz keramischer Materialien im Freien einige Grundregeln beachtet werden, damit die Bodenbeläge nicht vom Frost angegriffen werden können. Die wichtigsten Voraussetzungen sind: korrektes Gefälle, Abdichtung, Dehnungsfugen sowie geeignetes Verlegematerial.
- Dekore mit Glasuren und Edelmetallen Während der Verlegung muss die Oberfläche unbedingt abgedeckt werden. Es dürfen keine scheuernden und/oder säurehaltigen Produkte verwendet werden, sondern ausschließlich Wasser und neutrale Seife. Der Hersteller haftet nicht für eventuelle, während der Verlegung durch Abrieb entstandene Schäden an diesen hochwertigen Materialien. Reklamationen von bereits verlegtem Material werden in keinem Fall akzeptiert.

- Pour obtenir le meilleur résultat de pose de produits rectifiés, il est conseillé de réaliser un joint de 2 mm.
- Pour parfaire l'effet esthétique obtenu, Piemme conseille de confectionner des joints de la même couleur que les carreaux.
- Vérifier avant la pose la compatibilité et convenance des remplissages pour joints avec le produit céramique.
- Enlever les surplus des remplissages pour joints alors qu'ils sont encore frais.
- Respecter scrupuleusement les instructions indiquées par les fabricants de remplissages pour joints.
- Pour éliminer complètement tout résidu de pose pouvant gêner l'entretien courant et altérer les caractéristiques du produit, il est conseillé, à la fin de la pose, de procéder au nettoyage du carrelage avec des produits à base acide maximum 3% et de respecter les consignes du fabricant. Suivre impérativement les délais indiqués dans la notice car le contact trop prolongé de ces produits pourrait endommager la surface.
- Pour éliminer facilement la présence éventuelle de cernes après la pose de carreaux rodés ou polis, utiliser un produit à base alcaline.
- Pour ce qui est de la pose à l'extérieur, bien que les produits Piemme en grès cérame soient ingélifs, conformément aux normes européennes EN 14411/ISO 13006-ISO 10545.12, il convient cependant de respecter quelques règles fondamentales de manière à rendre le carrelage inattaquable au gel. Les conditions les plus importantes à remplir sont: le degré d'inclinaison, l'imperméabilisation, les joints de dilatation et l'utilisation de matériaux de pose appropriés.
- Décors réalisés avec des émaux et des métaux précieux Il est indispensable de protéger la surface pendant la pose. N'utiliser en aucun cas des produits abrasifs et/ou acides mais uniquement de l'eau et du savon neutre. Le fabricant ne répond pas des dommages éventuels de ces matériaux précieux causés par le frottement pendant la pose. Aucune réclamation, quelle qu'elle soit, concernant le matériau posé ne sera acceptée.







TIPO DI SPORCO	INDICAZIONI PER LA PULIZIA
Birra, Caffè, Gelato, Vino Gomma Pneumatico, Grassi vegetali e animali, Inchiostri, Lampostil Olii Meccanici, Residui di scotch Ollo di lino, PennarelloResine Smalti, Tintura per capelli	Prodotti a Base Alcalina
Cera protettiva anti-abrasione, Depositi calcarei, Macchie di ruggine	Prodotti a Base Acida
Cera di candela, Residui di scotch	Solventi
Per ulteriori informazioni specifiche consultare l'area tecnica sul sito Piemme: <a href="http://www.ceramichepiemme.it">www.ceramichepiemme.it</a>	

TYPE OF STAIN	CLEANING SUGGESTIONS
beer, coffee, wine, ice cream vegetable and animal fats, rubber, remains of scotch tape, grease from machines, linseed oil, felt tip pens, paints, inks, hair dye	Alkaline-based detergent
protective anti-abrasion wax, calcareous residuals, rust stains	Acid-based detergent
candle wax, remains of scotch-tape	Solvents
For further specific details please visit the technical area on Piemme website: <a href="http://www.ceramichepiemme.it">www.ceramichepiemme.it</a>	

VERSCHMUTZUNGSART	REINIGUNGSHINWEISE
Bier, Wein, Eis, Kaffee Tierische oder pflanzliche Fette Gummi, Kleberbandresten Schmieröl, Tinte, Leilöl, Filzstift, Harz oder Lack, Haarfarbe	Alkalische Reinigungsmittel
Kratzenschutz-Wachs, Kalkablagerunge, Rostflecken	Säure-Reinigungsmittel
Kerzenwachs Kleberbandresten	Lösungsmittel
Weitere Einzelheiten finden Sie in dem technischen Bereich des Piemme website: <a href="http://www.ceramichepiemme.it">www.ceramichepiemme.it</a>	

TYPE DE TACHE	NETTOYAGE CONSEIL
Bière, Vin, Glace, Café, Graisses végétales et animales, Encres, Résidus de scotch, Huile de graissage, Hile de lin Crayon feutre Emaux, Teinture pour cheveux, Caoutchouc pour pneus	Détergents à base alcaline
Cire de protection anti abrasion, Dépôts de calcare, Tache de rouille	Détergents à base d'acide
Cire de bougie Résidus de scotch	Solvant
Pour d'ultérieures Information spécifiques consulter le département technique du site Piemme: <a href="http://www.ceramichepiemme.it">www.ceramichepiemme.it</a>	

Reading Guide  
Leseanleitung  
Guide à la lecture

<p> Spessore Thickness Stärke Épaisseur</p>	<p>Variazione nelle sfumature di colore Color shade variations Variation der Farbnuancen Variation des nuances de couleur</p>	<p>Resistenza alla scivolosità Skid resistance Rutschfestigkeit Resistance au glissement</p>						
<p> Fascia prezzo al metro quadrato Square meter price range Quadratmeter preisgruppe Niveau de prix au mètre carré</p>	<p> V1 Aspetto uniforme Uniform appearance Gleichförmiges aussehen Aspect uniforme</p>	<table border="1" data-bbox="1132 479 1347 578"> <tr> <td>DIN 51130</td> <td>DIN 51097</td> <td>DCOF</td> </tr> <tr> <td>R10</td> <td>A</td> <td>&gt;0,42</td> </tr> </table>	DIN 51130	DIN 51097	DCOF	R10	A	>0,42
DIN 51130	DIN 51097	DCOF						
R10	A	>0,42						
<p> Fascia prezzo al pezzo Price range per piece Stück preisgruppe Niveau de prix à la pièce</p>	<p> V2 Variazione leggera Slight variation Leichte variation Variation légère</p>							
	<p> V3 Variazione moderata Moderate variation Mäßige variation Variation modeste</p>							
	<p> V4 Variazione casuale Random variation Zufällige variation Variation fortuite</p>							

Tutti i formati sono nominali.

All sizes are nominal.

Die Formate sind Nennwerte.

Tous les formats sont nominaux.

Gli spessori riportati in questo catalogo sono nominali e possono variare a seconda dei formati e delle finiture.

The thickness mentioned on this catalogue are nominal and can be different according to the sizes and the finishes.

Die in diesem Katalog angegebenen Fliesenstärke sind nominal und können, je nach Format oder Oberfläche, verschieden sein.

Les épaisseurs reportées sur ce catalogue sont nominales et peuvent varier suivant les formats et les finitions.

I colori e le caratteristiche estetiche dei prodotti sono quanto più possibile vicini a quelli reali, nei limiti consentiti dai processi di stampa.

The colours and appearance features of the products are as close as possible to reality, within the limitation of the printing process.

Die Farben und die ästhetischen Eigenschaften der Produkte entsprechen der Wirklichkeit, innerhalb den von dem Druckverfahren erlaubten Grenzen.

Les couleurs et les caractéristiques esthétiques sont fidèles aux couleurs et caractéristiques réelles dans les limites des procédés d'impression.



Ceramics of Italy rappresenta la volontà dell'industria italiana delle piastrelle di ceramica nel diffondere e promuovere una nuova valenza della piastrella di ceramica: non più solo un prodotto per l'industria delle costruzioni, ma punto di riferimento per stile e creatività per lo sviluppo di una nuova cultura dell'abitare Made in Italy.

Ceramics of Italy represents the willingness of the Italian ceramic tile industry to spread and promote a new concept of ceramic tile: no longer just a product for the construction industry, but a focal point for style and creativity in the development of a new culture of living Made in Italy.

Project Management  
Mktg Piemme

Gennaio 2020  
January 2020

#### Una storia tutta italiana

Piemme dal 1962, anno della sua fondazione, è protagonista indiscussa del vero Made in Italy, quello fatto di eccellenza, passione e creatività. Oggi tutti i materiali Piemme sono prodotti con tecnologia d'avanguardia come la decorazione digitale inkjet HD, la cottura in forni ad energia pulita a recupero di calore, la rettifica e levigatura in linea "one roof" e la verifica elettronica dello standard qualitativo.

#### An all-Italian story

Since 1962, the year of its foundation, Piemme has been the undisputed protagonist of real Made in Italy, that which consists of excellence, passion and creativity. Today, all Piemme materials are made using cuttingedge technology such as HD inkjet digital decoration, firing in heat-recycling cleanenergy kilns, "one roof" grinding and polishing line and electronic quality standard control.

#### Eine ganz italienische Geschichte

Seit dem Gründungsjahr 1962 ist Piemme ein unangefochtener Hauptakteur des echten Made in Italy: jenem, das auf Exzellenz, Leidenschaft und Kreativität gründet. Alle Piemme Erzeugnisse werden heute unter Einsatz von Spitzentechnologie produziert, wie zum Beispiel mit der digitalen Inkjet-Dekoration, dem Brennen in Öfen mit grüner Energie und Wärmerückgewinnung, dem Schleifen und Polieren in der Linie „unter einem Dach“ sowie der elektronischen Prüfung des Qualitätsniveaus.

#### Une histoire toute italienne

Depuis 1962, l'année de sa fondation, Piemme est la protagoniste indiscutée du Made in Italy, basé sur l'excellence, la passion et la créativité. Aujourd'hui toutes les phases du cycle de fabrication Piemme sont issues d'une technologie à l'avant-garde comme la décoration numérique inkjet HD, la cuisson dans des fours à énergie propre et à récupération de chaleur, la rectification et le polissage en en ligne "one roof" et la vérification électronique de la qualité.

# CERAMICHE PIEMME

FLOOR AND MORE

INDUSTRIE CERAMICHE PIEMME S.P.A.  
VIA DEL CROCIALE 42/44, 41042 FIORANO (MO) - ITALY  
T. +39 0536.849111 - F. +39 0536.849402  
WWW.CERAMICHEPIEMME.IT - INFO@CERAMICHEPIEMME.IT