

Owners Manual



Assembly and Maintenance Instructions For Models JNR4, WNK4, WRG4, WHRG4, TJK2, TRG2, and THRG2 Series

THIS GAS APPLIANCE IS DESIGNED FOR OUTDOOR USE ONLY.



⚠ FOR YOUR SAFETY

If you smell gas:

1. Shut off gas to appliance.
2. Extinguish any open flame.
3. Open Lid.
4. If odor continues, immediately call your gas supplier or your fire department.



⚠ FOR YOUR SAFETY

1. Do not store or use gasoline or other flammable vapors and liquids in the vicinity of this or any other appliance.
2. An LP cylinder not connected for use shall not be stored in the vicinity of this or any other appliance.



⚠ FOR YOUR SAFETY

Follow all leak-test procedures carefully in this manual before using. Do this even if the grill was dealer assembled. Do not try to light this appliance without reading the "Lighting" instructions in this manual.



**YOU MUST READ THIS OWNERS
MANUAL BEFORE OPERATING
YOUR GAS GRILL.**



**THESE INSTRUCTIONS SHOULD BE LEFT WITH
THE CUSTOMER. KEEP THESE INSTRUCTIONS
FOR FUTURE REFERENCE.**

Safety



















DANGER

Failure to follow the Dangers, Warnings and Cautions contained in this Owner's Manual may result in serious bodily injury or death, or in a fire or an explosion causing damage to property.



WARNINGS

-  Do not store a spare or disconnected liquid propane cylinder under or near the barbecue.
-  Improper assembly may be dangerous. Please carefully follow the assembly instructions in this manual.
-  After a period of storage, and/or nonuse, the MHP Gas Barbecue Grill should be checked for gas leaks and burner obstructions before use. See instructions in this manual for correct procedures.
-  Do not operate the MHP Gas Barbecue Grill if there is a gas leak present.
-  Do not use a flame to check for gas leaks.
-  Combustible materials should never be within 18 inches of the bottom, back or sides of your MHP Gas Barbecue Grill.
-  Do not put a barbecue cover or anything flammable on, or in the storage area under the barbecue.
-  Children should never use your MHP Gas Barbecue Grill. Accessible parts of the barbecue may be very hot. Keep young children away while it is in use.
-  You should exercise reasonable care when operating your MHP Gas Barbecue Grill. It will be hot during cooking or cleaning and should never be left unattended, or moved while in operation.
-  Should the burners go out while in operation, turn all gas valves off. Open lid and wait five minutes before attempting to relight, using the lighting instructions.
-  Do not use charcoal or lava rock in your MHP Gas Barbecue Grill.
-  Never lean over open grill or place hands or fingers on the front edge of cooking box.
-  Do not enlarge the valve orifices or burner ports when cleaning the valves or burners.
-  The MHP Gas Barbecue Grill should be thoroughly cleaned on a regular basis.
-  Liquid propane gas is not natural gas. The conversion or attempted use of natural gas in a liquid propane unit or liquid propane gas in a natural gas unit is dangerous and will void your warranty.
-  Do not attempt to disconnect any gas fitting while your barbecue is in operation.
-  Use heat-resistant barbecue mitts or gloves when operating barbecue.

LIQUID PROPANE GAS UNITS ONLY





-  Use the regulator that is supplied with your MHP Gas Barbecue Grill.
-  Do not attempt to disconnect the gas regulator or any gas fitting while your barbecue is in operation.
-  A dented or rusty propane cylinder may be hazardous and should be checked by your local liquid propane supplier. Do not use a liquid propane cylinder with a damaged valve.
-  Although your liquid propane cylinder may appear to be empty, gas may still be present, and the propane cylinder should be transported and stored accordingly.
-  If you see, smell or hear the hiss of escaping gas from the liquid propane cylinder:
 1. Move away from the liquid propane cylinder.
 2. Do not attempt to correct the problem yourself.
 3. Call your fire department.

TABLE OF CONTENTS

Safety (<i>Dangers & Warnings</i>).....	2
Warranty.....	4
General Instructions.....	5
Mountings.....	6 -13
<i>Cart</i>	6- 7
<i>Deck/Patio</i>	7-9
<i>In-Ground</i>	9
<i>Optimum Console</i>	10-11
<i>Built-In</i>	12-13
JNR/WNK Grill Assembly.....	14-18
TJK Grill Assembly.....	19-20
WRG4 & TRG2 Assembly.....	21-22
WHRG4 & THRG2 Assembly.....	23-24
Gas & LP Tank Connections.....	25-26
Leak Testing & Lighting The Grill.....	27
Maintenance.....	28-29
<i>Annual Maintenance</i>	28
<i>General Maintenance</i>	28-29
Tube Bending.....	30
Troubleshooting.....	31



MHP Grill upgrade options for added versatility, convenience and cooking enjoyment.



Reversible for total cooking versatility.

Exclusive, rust-free anodized aluminum cooking grids. This unique cooking system heats up faster, reduces flare ups and cooks all foods at a higher temperature, thereby searing in the delicious barbecue juices. Wide-ribbed side for grilling steaks, chops, burgers and ribs, branding them with sear lines. The flip side, with its smooth surface is ideal for grilling delicate foods such as fish, seafood and vegetables.



Stainless Steel Side Burner.
The premium commercial grade stainless steel side burner is 12,000 BTU rated, has its own electronic ignition, and is factory assembled for simple drop-in installation.



Infra-Roast™ Rotisserie Burner System. Infra-red rear burner heats up fast to quickly put a seal around meats for juicier and more moist results. Constructed of commercial grade stainless steel and is easy to install or remove for normal grilling.

LIMITED WARRANTY

Modern Home Products Corp. Offers to the original purchaser a Limited Warranty on all grill components as described below. These components will be free from defects in material and workmanship (excluding paint) when subject to normal domestic use and service. The highest quality paint is used where applicable, but due to various atmosphere conditions, chemicals, fertilizers, care, cleaning and actual use, no extended warranty can be made on paint. Also, for these reasons the limited warranty does not cover rust or aluminum oxidation, unless there is a loss of structural integrity on the grill components.

Warranty coverage begins on the original date of purchase, confirmed by return registration card and bill of sale. Proof of purchase is required to validate warranty.

Any component that proves defective within the warranty period will, if returned to the factory freight prepaid, be repaired or replaced free of charge. Warranties shall not apply, nor will MHP assume responsibility for damages that might result from failure to follow MHP's instructions, local codes, or when the grill has been tampered with, or altered in any way MHP shall not be liable for any transportation charges, labor costs, or export duties.

Repair or replacement of a MHP gas grill part does not extend the limited warranty beyond its original term from date of purchase, or begin a new limited warranty period.

This warranty does not include the cost of any inconvenience or property damage due to the failure of the product and does not cover damage due to misuse, abuse, accident, damage arising out of transportation of the product, or damage incurred through commercial use of the products. This express warranty is the sole warranty given by the manufacturer and is in lieu of all other warranties, expressed or implied, including implied warranty of merchantability or fitness for a particular purpose.

ALL WARRANTIES are null & void if grills are put into commercial or community use such as by hotels, condominium associations, apartment committees, etc.

MODERN HOME PRODUCTS CORP., 150 S. Ram Road, Antioch, IL 60002

Gas Grill Warranty Terms

Lifetime

Top Casting • Bottom Casting • Control Panel • Side Shelf Brackets • Bottom Shelf Frame • Tank Ring • Cast Legs
• Stainless Steel Fasteners • In-Ground & Patio Base Post • Stainless Steel Column • Stainless Steel Shelves
• Stainless Steel Burner • Venturi Tube • Stainless Steel & Sear Magic® Cooking Grids • Stainless Steel & Sear Magic® Warming Racks

5-Year Warranty: Infrared Burners and Porcelain Briquettes **1-Year Warranty:** All other Components Including; Ignitor System • Gas Valve • NuStone Side Shelves • Patio Base • Knobs • Rock Grate **30 Day Warranty:** Paint

WHAT IS NOT COVERED

- Transportation and shipping costs.
- Labor for replacement or repairs.
- Removal and reinstallation cost.
- The costs of a service call to diagnose a problem.
- Damage from accident, misuse, alteration, abuse, improper installation or storage.
- Inoperable due to improper installation or storage.
- Finishes on surface that are damaged by improper installation, improper storage, accident, misuse, abuse or alteration.
- All warranties are non-transferable and apply only to the original purchaser.
- Warranties are null & void if grills are put into commercial or community use.
- Burners, clogged due to rust or food residue.

This warranty does not imply or assume any responsibility for consequential damages that might result from use, misuse, or improper installation of this cooking appliance.

This warranty does not cover claims which do not involve defective workmanship or materials.

A bill of sale, cancelled check, or payment record should be kept to verify purchase date and establish warranty period.

MODEL IDENTIFICATION

Your MHP Gas Barbecue Grill is identified by a model number and a serial number located on the left side of the control panel. Always use both the model and serial numbers when contacting Modern Home Products about your grill. For future reference, take the time now to record the model and serial numbers below:

MODEL NUMBER: _____ SERIAL NUMBER: _____ DATE PURCHASED: _____

How to contact us: phone: 1-888-647-4745, fax: 1-800-637-2918, E-mail: customerservice@mhpgrills.com or write: Customer Service, Modern Home Products, 150 S. Ram Road, Antioch, IL 60002.

General Instructions

GENERAL INSTRUCTIONS

This installation guide provides you with easy to follow illustrations and instructions to assemble your MHP Gas Barbecue Grill.

Before you start assembling and using your MHP Gas Barbecue Grill we recommend that you read through all precautions, safe guards and instructions to avoid any personal injury or property damage.

Check Local Codes. Contact your local LP dealer or Natural Gas company for recommended installation procedures and regulations. If there are no local codes, installation must conform to the latest National Fuel Gas Code: ANSI Z 223.1. For Canada, installation must comply with local codes and/or Standard CAN/CGAB-149-1 for natural gas installation and CAN/CGA-B-149-2 for propane installation.

For LP Gas Models the supplied Gaslow GS-801 Regulator must be used. Any replacement pressure regulator or hose assembly must meet or exceed the specifications of the Gaslow GS801 Regulator.

For Natural Gas Models the grill is designed to operate at a pressure of 7" water column (W.C.) (1.75 kPa). Check your gas utility for local pressure. Pressures other than approximately 7" W.C. could affect the performance of your grill.

ASSEMBLY INSTRUCTIONS

There are 9 steps to assembling your MHP Gas Barbecue Grill : The mounting, LP tank mounting, control panel, gas supply connection, grill lid, lid handle, side shelves, and rock grate, cooking grid and warming rack.

The grill itself is partially assembled with the Burner, Venturis, Ignitor Collector Box and the Gaslow Regulator installed.

The JNR, WNK and TJK grills are specifically designed to fit the five mounting methods: Cart, In-Ground Post, Deck/Patio Base, Column and Built-in.

You will need the following tools to assemble your grill:

- A Phillips head screwdriver
- A standard flat head screwdriver
- Two 7/16" wrenches or sockets

STORAGE

Turn gas OFF at the LP cylinder (or at the shut OFF valve in the case of Natural Gas) when the MHP Gas Barbecue Grill is not in use.

Do not store spare LP cylinders under the MHP Gas Barbecue Grill.

Store disconnected LP cylinders outdoors in a well-ventilated area, do not store in shed, building, garage or in any enclosed area.

OPERATING SAFEGUARDS

- ⚠ **Do not install your MHP Gas Barbecue Grill in or on recreational vehicles and/or boats.**
- ⚠ **Never use your MHP Gas Barbecue Grill near combustible surfaces, including roof overhangs, roofs, vinyl siding and window shutters.**
- ⚠ **Use this barbecue outdoors in a well-ventilated area.**
- ⚠ **Do not use your MHP Gas Barbecue Grill in a shed, garage, building, breezeway or any other confined area.**
- ⚠ **Do not use any kind of combustible material on or near the top, bottom, back or sides of the grill. Maintain at least an 18 inch clearance.**
- ⚠ **Leak test all gas supply line connections.**
- ⚠ **Do not let children operate a gas grill.**
- ⚠ **Keep the area around the grill clear of combustible vapors or liquids such as gasoline.**
- ⚠ **When operating the grill do not leave unattended. Keep children and pets away.**
- ⚠ **Keep fuel supply hose and electrical supply cord away from any heated surface.**

⚠ SAFETY

YOUR GRILL IS DESIGNED FOR OUTDOOR USE ONLY.

It should also not be used in an enclosed area such as a shed or garage because combustion uses available oxygen and discharges carbon monoxide.

The grill must be located no closer than 18" from any combustible surface behind or to the sides. Grill should not be located under overhead unprotected combustible surfaces.

Keep the area around the grill clear of combustible materials, flammable vapors or liquids such as gasoline.

Do not obstruct the flow of combustion and ventilation air.

Mountings

Duro-Cast Cart

Carton contains the following components for the cart mounting:
Please check to be sure that all parts are included before proceeding.
Contact your dealer or the factory if any parts are missing.

CART HARDWARE	WCP3 (WNK4, WRG4, WHRG4, TJK2, TRG2, THRG2)	WCN3	JCP3 (JNR4)	JCN3
Grill Heads				
Long Legs	2	2	2	2
Short Legs	2	2	2	2
Lower Shelf Frame	1	1	1	1
Stainless Grease Cup	1	1	1	1
8" Rubber Wheels	2	2	2	2
Axle 22 1/2"	1	1	1	1
Axle Hitch Pins	2	2	2	2
Axle Washers	2	2	2	2
Hub Caps	2	2	2	2
Hose Retaining Ring	1	1	1	1
1/4-20x1-1/2 Slotted Bolt	10	10	8	8
1/4-20x3/4 Slotted Bolt	2	2	4	4
1/4-20 Kep Nut	10	10	8	8
10-24x1/2" Rd.Hd. Slot	1	1	1	1
10-x24 Kep Nut	1	1	1	1
12" Nat. Gas Hose Kit	N/A	1	N/A	1

Tank Ring Kit

Tank Ring	1	N/A	1	N/A
1/4-20x1-1/2" Slotted Bolt	1	N/A	1	N/A
1/4-20x 3/4" Hex Bolt	1	N/A	1	N/A
1/4-20 Thumb Screw	1	N/A	1	N/A
1/4-20 Kep Nut	3	N/A	3	N/A

Complete View of Cart Assembly

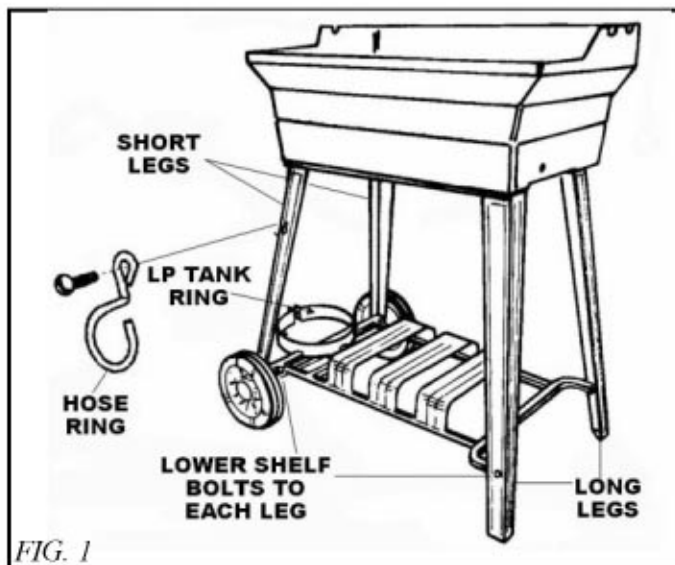

FIG. 1

Step 1: Leg Assembly (Fig 2)

1. Tip the grill head bottom on end as shown in Fig. 2 (TIP: work on protected area such as: carpet, tarp or one of the boxes to protect cart finish).
2. Attach the two short legs to the left end of the grill head bottom with the "Hose Ring Hole" leg facing grill front. **Note: The short legs are stamped on the inside (Front or Back).** Use two 1/4-20x1-1/2" slotted bolts for each leg. Insert bolts from inside grill box, attach leg and fasten with 1/4-20 Kep nuts.
3. Attach the two long legs to the right end of the grill head bottom. Use two 1/4-20x1-1/2" slotted bolts for each leg, insert bolts from inside grill box, attach leg and fasten with 1/4-20 Kep nuts.
4. Attach the hose clamp ring to the front left short leg with the 10x24x1/2" Rd. Hd. slotted bolt.

FINGER TIGHTEN ALL BOLTS UNTIL LOWER SHELF IS ATTACHED.

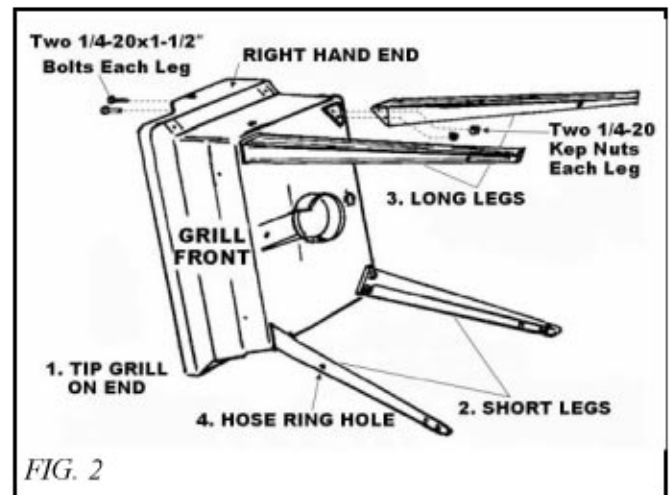

FIG. 2

Step 2: Lower Shelf and Axle Assembly

1. Bolt shelf to the (4) legs as follow:
(A) WCP and WCN (Fig. 3) carts uses (2) 1/4-20x 1-1/2" slotted bolts and Kep nuts to fasten the frame to the long legs and (2) 1/4-20x3/4" slotted head bolts to fasten the frame to the short legs.
(B) JCP and JCN (Fig. 4) carts use (4) 1/4-20x 3/4" slotted head bolts to fasten the frame at all 4 corners.

Note: Do Not Completely Tighten At This Point

2. Install (1) axle hitch pin into the small end hole and install washer. Slide (1) wheel onto axle, hub-cap side out.
3. Slide open axle end through the short leg holes and install remaining wheel, washer and hitch pin. Install hubcaps after the cart bolts are completely tightened.

Stand grill upright to seat legs and tighten all bolts and nuts making legs and frame rigid. Recheck fasteners for tightness.

Step 3: WCP3/WCN3 Lower Shelf Assembly (Fig. 3)

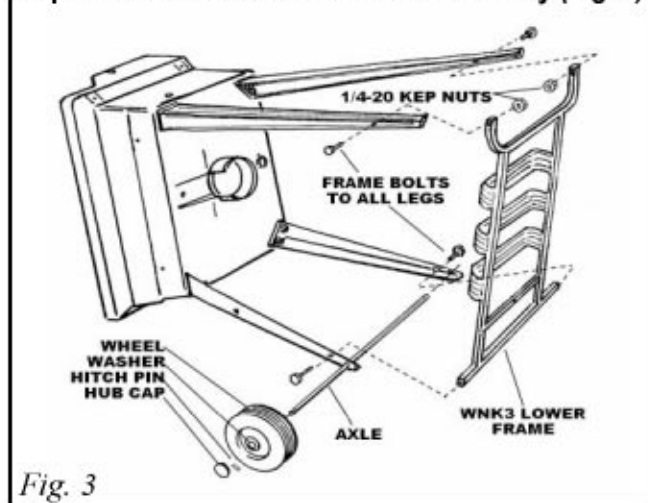

Fig. 3

Step 3: JCP3/JCN3 Lower Shelf Assembly (Fig. 4)

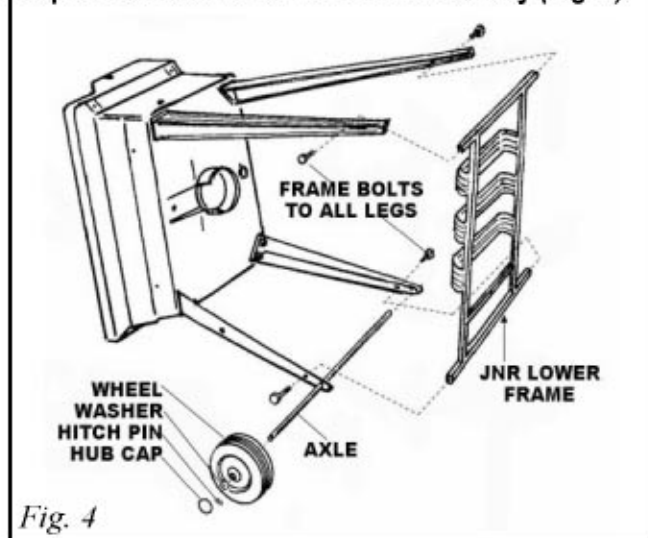

Fig. 4

Step 3: Tank Holder Ring Assembly For LP Gas Models (Fig. 5)

1. The LP Tank Holder Ring Connects to the lower shelf cross frame with the ring notches resting on the axle frame.
2. Align the rear tank ring-fitting hole over the lower cross frame hole. Insert a 1/4-20x5/8" slotted bolt through the top and fasten with a 1/4-20 Kep nut from below.
3. Fasten the thumb screw (1/4-20x3/4") to the tank ring fitting with the 1/4-20 Hex nuts. The Hex nut slips into the captive slot on the tank ring fitting.
4. Use a 1/4-20x1-1/2" slotted bolt and a 1/4-20 Kep nut to connect the tank holder flanges together.

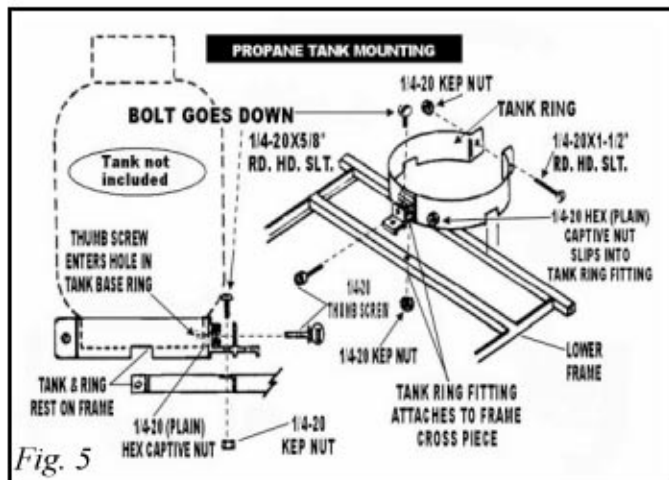

Fig. 5

For Natural Gas Models

(Note: Tank Holder Ring is not Included With Natural Gas Models).

Natural Gas Models

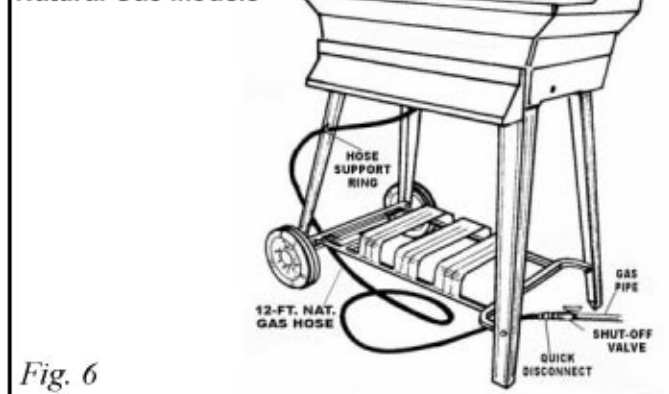

Fig. 6

If the grill is to use Natural Gas from the supplied 12-foot hose (Fig. 6): the hose must pass through the hose ring (See Fig. 1). The hose will have a quick-disconnect fitting at the source and the source will have a gas shut off valve with easy access.

When you have completed the mounting assembly go to the appropriate Grill Assembly Section and Assemble the grill head.

Deck/Patio Mounting Assembly Instructions (MPB)

- All grill head models may be mounted on the Deck/Patio base.
- The gas supply may be either LP or Natural.
- The grill head bottom should not be attached to the post until the mount is fasten to a deck/patio.

Mountings

Deck/Patio Base

- Deck/Patio base fits all MHP Grill Heads
- The gas supply may be either LP or Natural.
- The grill head should not be attached to the post until the base has been mounted to the deck or patio.

Please check to be sure that all parts are included before proceeding. Contact your dealer if any parts are missing.

Parts	Quantity
2' Post	1
Patio Base	1
Post Access Door	1
Grease Cup Holder	1
28" Stainless Steel Tubing	1
Stainless Steel Grease Cup	1
Hardware Kit	
¼ - 20 x ¾" Hex Head Bolts	7
¼ - 20 Kep Nuts	7
¼" Flat Washers	7
8 - 32 x ½" Self Tapping Screw	1
Tube Clip	1

Step 1: Deck/Patio Base Mounting Assembly (Fig. 5)

1. Turn base on edge and insert the 2' post. Align the notches in the post with the notches in the base. **IMPORTANT:** Close tolerances may require you to tap the top of the post to seat it completely in the base socket which will then align the bolt slots.
2. Fasten post to base with four ¼ - 20 x ¾" Hex bolts, washers and Kep nuts. Follow exact placement of washers as indicated. Tighten securely.
3. Attach the tube clip with the 8 - 32 self-tapping screw either on the right or left side of the base depending on the direction of your gas supply line.

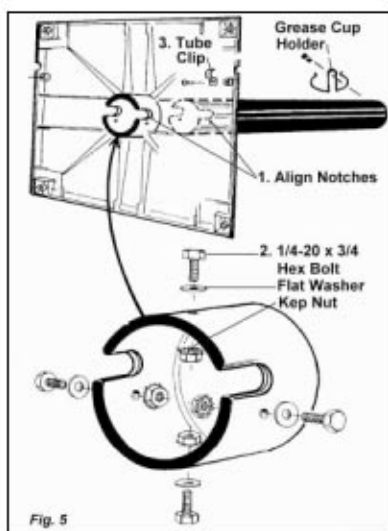

Step 2: Deck/Patio Mounting Installation (Fig. 6)

Position the patio base at the desired location on a deck or patio. **CAUTION:** Be certain there are no combustible materials above, behind, left or right closer than 18" away.

1. Mark the location of the four holes at the outside corners of the patio base and drill four holes. The base will be fastened down with lag bolts (not supplied by MHP) after you have connected the gas supply line. The top post notch is the front and the rear access door will be in the back of the grill.
2. Run the gas supply line into the post from the bottom to reach the access door and bend it 90° to exit the base at either notch. The patio base is notched on two sides to allow the gas line to exit either right or left.
3. Secure the gas line with the tube clip. (Option: On a raised deck if the gas supply line is to be run straight up into the post from below use the tube clip to attach the gas line to the deck for support.)
4. At the access door connect a 3/8" flare coupling (not supplied by MHP) to the gas supply line and Stainless Steel tubing. Position the tubing in the top notch of the post. Bend the tubing at the top end to match the Feed Line of the grill valve. **Do not kink the tubing.**

TUBE BENDING: For proper bending of the stainless steel tubing, see page 26 for bending instructions.

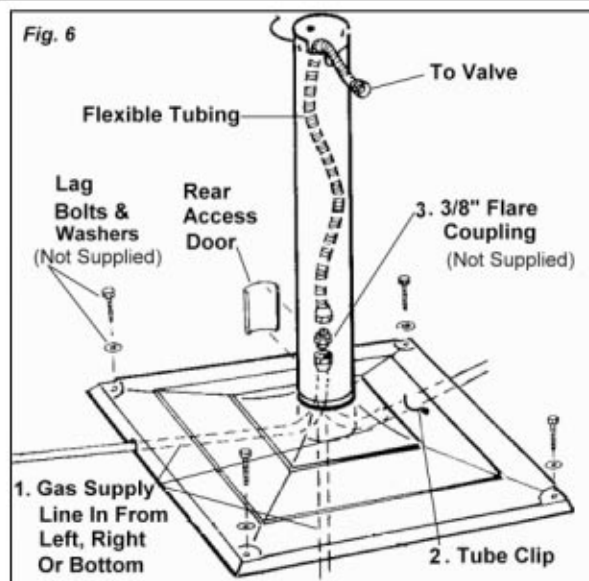

Step 3: Attaching The Grill Head Bottom To The Deck/Patio Post (Fig. 7 & Fig. 8)

1. To make the post-to-flange connection easier, remove the grill burner by taking out the small clip located under the bottom grill head. This will allow access to hold the Kep nuts inside the post.
2. Set the grill head bottom carefully in place, align holes and use the ¼ - 20 x ¾" bolts and ¼-20 Kep nuts to attach the grill flange to the post.

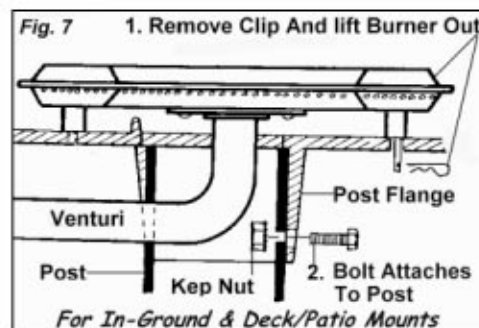

Mountings

3. Mount the grease cup holder to the rear flange hole with a 1/4 - 20 x 3/4" bolt and 1/4-20 Kep nut. The grease cup holder is supplied with the grill head.

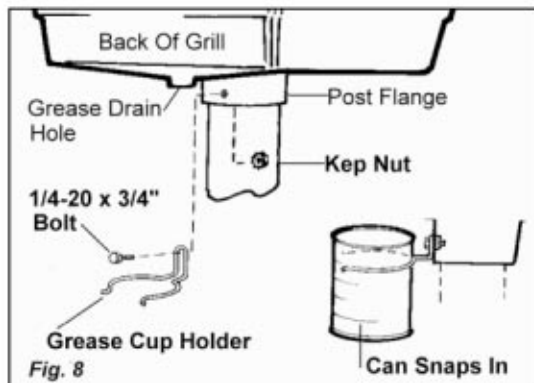

When you complete the mount assembly go to the appropriate Grill Assembly Section and assemble the grill head.

In-Ground Mounting Assembly Instructions (MPP)

- All MHP Grill Heads may be mounted on the 4 foot post for in-ground installation.
- The gas supply may be either LP or Natural.
- The grill head should not be attached to the post until the post is permanently cemented in ground.

Please check to be sure that all parts are included before proceeding. Contact your dealer if any parts are missing.

Parts	Quantity
4' Post	1
Post access door	1
28" Stainless Steel Tubing	1
Stainless Steel Grease Cup	1
Stainless Grease Cup Holder	1
1/4 - 20 x 3/4" Hex Head Bolts	3
1/4 - 20 Kep Nuts	3

Step 1: In-Ground Mounting Installation (Fig. 9)

1. Dig a posthole about 8 inches wide by 2 feet deep. **Caution:** Locate the hole so that the mounted grill head has a clearance of 18 inches away from any combustible object or surface; back, left or right. Center the post in the hole and plumb it. Pour in cement (gravel) up to the gas line access hole.

Keep in mind that the gas line access hole is on the back of the post and the notch at the top if facing front. Recheck plumb and allow cement to set.

2. Run the gas supply line into the post access hole (just above the cement). Make a 90° bend to reach the access door opening.

The gas supply line should be trenched at least 18 inches below the surface of the ground to prevent damage from digging. **CAUTION: The gas supply line must be regulated (in the case of natural gas that means connected after your gas meter and regulator) and that you have an easily accessible shut-off valve.**

3. At the access door connect a 3/8" flare coupling (not supplied by MHP) to the gas supply line and Stainless Steel tubing. Position the tubing in the top notch of the post. Bend the tubing at the top end to match the Feed Line of the grill valve. Do not kink the tubing.

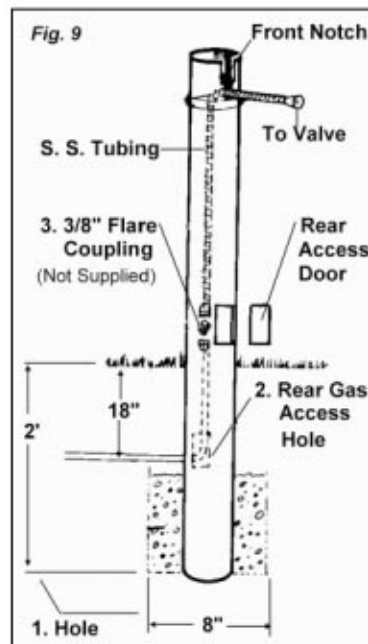

TUBE BENDING. For proper bending of the stainless steel tubing, see page 26 (Fig. 47) for bending instructions.

Step 2: Attaching The Grill Head Bottom To The In-Ground Post (Fig. 7 & 8)

To attach the grill head to the post please refer to Step 3 of the Deck/Patio installation procedures on page 8 and follow instructions.

When you complete the mount assembly Go to the appropriate Grill head section and assemble the Grill Head.

Mountings

Stainless Steel and Aluminum Column Assembly Instructions

- All MHP Grill Heads may be mounted on the Column.
- The gas supply may be either LP or Natural.
- The grill head should not be attached to the Column until the console is completely assembled.
- The Column comes in two cartons—Box A contains the console and all associated hardware. Box B contains either the pedestal or cart base and all base hardware.

Please check to be sure that all parts are included before proceeding. Contact your dealer if any parts are missing.

Parts

Quantity

BOX A

Stainless Steel Front Panel	1
Stainless Steel or Aluminum Column	1
Stainless Grease Cup	1
Tank Lock Bar	1

Hardware Kit

Nylon Lock Bar Spacers	2
¼ - 20x1¼" S.S. Hex Head Bolts	4
¼ - 20 S.S. KEP Nuts	12
¼ S. S. Washers	10
¼ - 20 x ¾" S.S. Hex Bolts	8
Rectangular Washers	4
2-piece Gasket (Stainless Steel Column Only)	1
Aluminum Reinforcing Bar (Aluminum Column Only)	2

BOX B

Cast Aluminum Base	1
12' Nat. Gas Hose/Quick Discount	1 (Cart Nat. Gas Only)
Stainless Steel Flexible Tubing, 28"	1 (Pedestal Nat. Gas Only)
Axle	1 (Cart Only)
Axle Clips	2 (Cart Only)
6" Wheels	2 (Cart Only)
Hub Caps	2 (Cart Only)

Note: While assembling, peel the thin white protective film covering from the stainless steel surfaces, especially in areas which will be partially hidden after assembled. Do Not Scrape off.

Step 1: Connect the Tank Locking Bar (Fig. 10)

1. From box "A" locate and attach the Tank Lock Bar across the back of the pedestal column. Use the ¾" S.S. Hex bolt, Nylon Lock Bar Spacer and a Kep nut on each side to fasten the Tank Lock Bar in place. This spreads and holds the correct spacing at the back of the column.

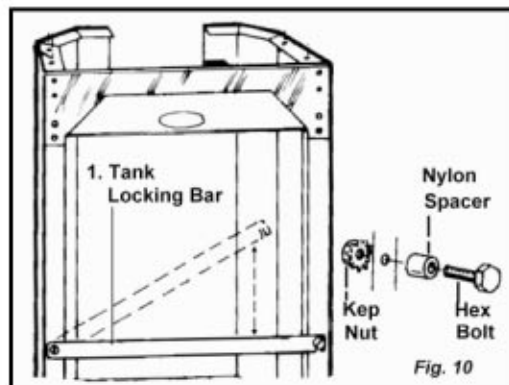

Step 2: Attach the Base to the Pedestal (Fig. 11)

1. Before bolting the pedestal column to the base, the 2-piece gasket (stainless steel column only) must be installed to create a barrier between the two metals. Remove the backing strips from the gasket to expose the adhesive and stick the gasket to the bottom lip of the pedestal column. **Make sure to align the holes.**
2. Attaching the pedestal column to the base will be easier to handle by laying the pedestal column face down and matching the holes on the pedestal column lip to the holes on the base. Use six ¾" bolts, four large rectangular washers, and on the underside six round washers and KEP nuts. **IMPORTANT:** the large rectangular washers are used at the sides on top of the pedestal column lip. The round washers and KEP nuts are used under the base. Tighten securely and stand unit upright.

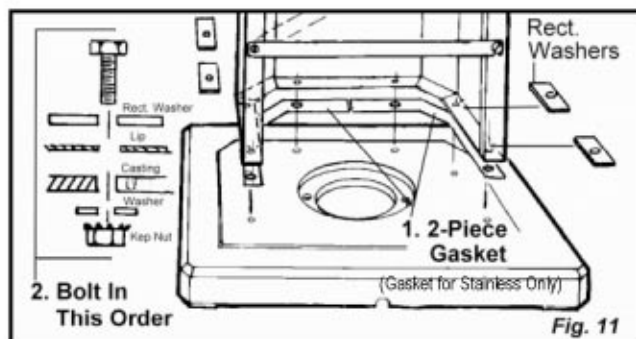

Mountings

OPTION: For Portable Base Only: (Fig. 12)

1. Attach the wheels by slipping the axle through the base, slide the wheels on and secure with the axle clips. Finish by snapping the hub caps on before standing unit upright. For units with casters, place caster stem into stem opening of the portable base, press and snap into place. (Fig. 12A)

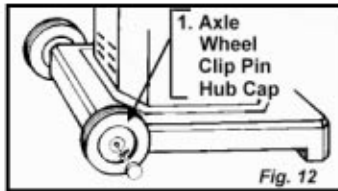

Step 3: Connect the Grill Head Bottom to Stainless Steel Column (Fig. 13)

1. Attach the grill head bottom to the pedestal column top with four ¼ - 20 x 1 ½" Hex bolts, washers under the bolt head and Kep nuts. Peel the remaining protective coating off the pedestal column.

Stainless Steel Column

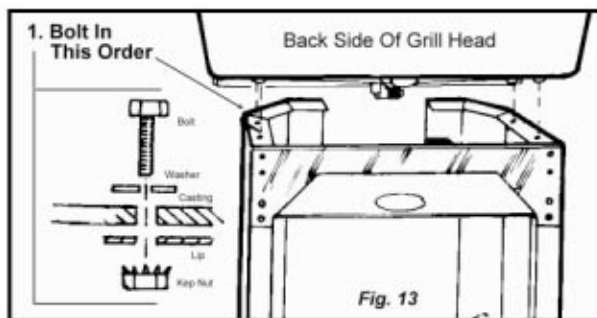

Step 3: Connect the Grill Head Bottom to Aluminum Column (Fig. 13A)

1. Attach the grill head bottom to the pedestal column top with four ¼ - 20 x 1 ½" Hex bolts, washers under the bolt head, reinforcing bar and Kep nuts.

Aluminum Column

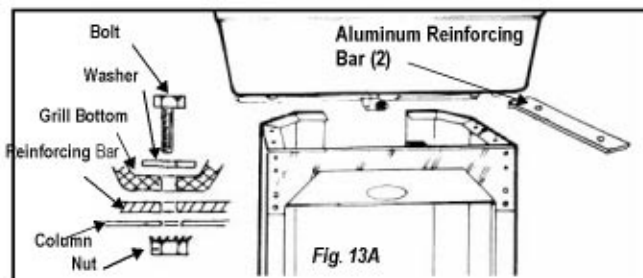

Step 4: Attaching the Access Panel (Fig. 14)

Note: Do not attach the front access panel until the control panel has been attached to the grill head bottom and the gas supply line has been properly connected and leak tested.

1. The front access panel attaches directly under the control panel and hides the access opening. Lift the access panel up behind the lip of the control panel, then slip the bottom double edge of the access panel (upward pressure may be needed) over the edge of the access opening.

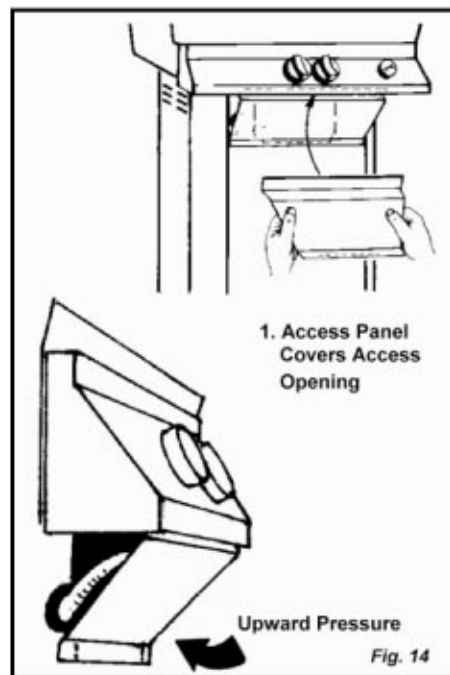

When you complete the mount assembly go to the appropriate Grill Assembly Section and assemble the grill head.

Caution: Combustible material should never be within 18 inches of the bottom, back or sides of your MHP Gas Barbecue Grill.

Mountings

Built-in Mounting Assembly Instructions (NMS-GS, NMS2-GS Enclosure Sleeve and NMS-DS Door Set)

- The WNK or TJK model grills may be mounted as a built-in with the NMS-GS enclosure sleeve.
- The WRG4, WHRG4, TRG2 and THRG2 requires the NMS2-GS enclosure sleeve.
- For use with natural or hard-plumbed propane gas.
- Do not place or store a spare LP gas cylinder under or near the grill.
- Enclosure must be constructed from non combustible materials and with adequate ventilation.
- The Built-In kit and grill head connection will be assembled upside down.
- Refer to appropriate section for grill head assembly.

Please check to be sure that all parts are included before proceeding. Contact your dealer if any parts are missing.

Parts	Quantity
GRILL HEAD ENCLOSURE SLEEVE	
Front Face Plate for NMS (26" W x 11"H x 1 1/2" D)	1
Right Side "L" Bracket 19" x 11"	1
Left Side "L" Bracket 19" x 11"	1
Rear Support Bracket 26 1/8" long	1
Grease Tray	1
Heat Shield	1
Hardware Kit	
1/4 - 20 x 3/4" Hex Its	12 1/4
20x1 1/4 "H ex Bolts	4
1/4" Nuts	4
1/4" Flat Washers	4
1/4" Lock Washers	16
NMS-DS DOOR SET	
Frame for Door Set	1
Left Hand Door	1
Right Hand Door	1
Magnetic Catches	2
Door Handles	2

Important Notes:

Your structure should have a 3" to 4" concrete base on a sand footing.

The panel doors must have a 4" to 6" minimum elevation from the ground.

If your structure includes a back splash, allow 11" to the back edge of grill opening to allow the lid to open completely.

Combustible material should never be within 18 inches of the bottom, back or sides of your Grill.

Complete View Of Built-In

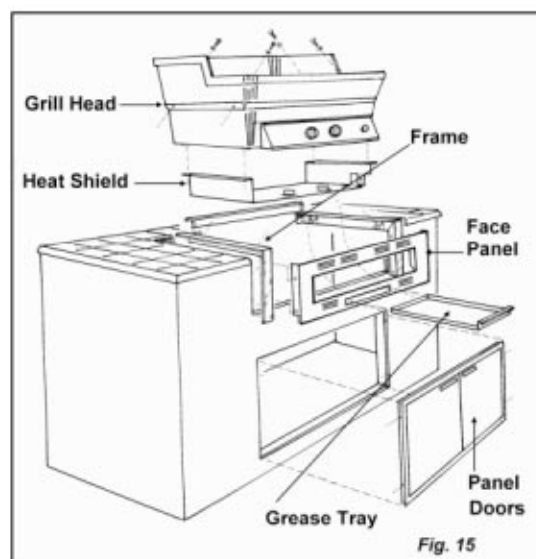

Step 1: Required Dimensions For Built-In (Fig. 16)

1. The grill head fits into an opening of 27 1/2" wide by 11" high by 18" deep.
2. The Panel doors fit into an opening of 27 1/4" wide by 16 3/4" tall.
3. The side burner fits a surface opening of 10 1/4" wide by 11 1/4" front to back. It should be at least 5" away from the grill opening.

(The front face flanges on the mounting and the panel doors overlap the required opening surfaces by 1 5/8" and provide a clean look.)

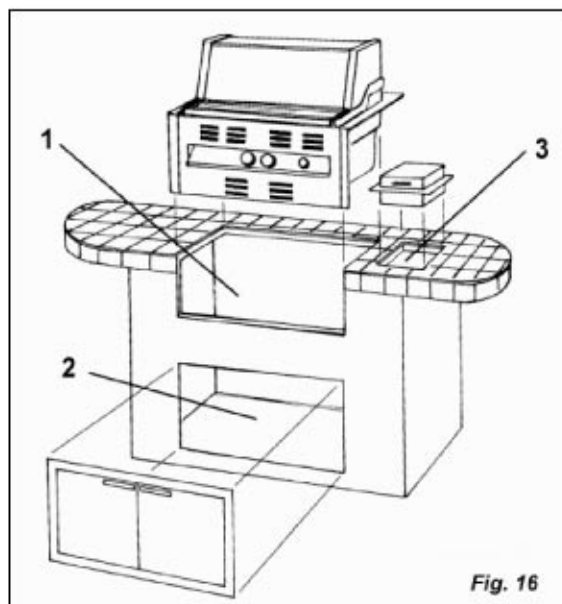

Step 2: Built-In Mounting Assembly

IMPORTANT: Since the mounting is attached directly to the grill, you must first partially assemble your grill by attaching the control panel to the grill head (refer to the appropriate grill section for a s-sembly instructions).

Then the built-in mounting heat shield must be attached to the bottom of the grill head using four 1/4-20 x 3/4" bolts, see *fig. 14* "Complete View" illustration.

Do not forget to remove the protective film from all stainless steel parts of your built-in mount.

To assemble the built-in frame (*Fig. 17*)

1. Align the holes of the right hand "L" bracket with the face panel (the face panel's 12 vent slots should be on the top) and insert two 1/4 - 20 x 3/4" Hex bolts and fasten with flat washer, lock washer and nut, do not tighten at this time. When properly connected the grill support tabs on the "L" bracket should be facing up and inward.
2. Repeat procedure to connect the left hand "L" bracket.
3. Attach the rear bracket to both the right and left "L" brackets using two 1/4 - 20 x 3/4" Hex bolts at each end. Secure bolts with a flat washer, lock washer and nut.
4. Attach the frame to the bottom grill head by aligning the frame support tabs with the grill head bottom holes. Insert the 1/4- 20 x 1 1/4" Hex bolt from inside the grill head and screw it into the threaded frame support tab.

To connect the full assembly to the enclosure.

5. Slide the grill head into the opening 3/4 of the way in. Connect the gas supply using an approved outdoor connector.
Check for gas leaks. (See Gas Leaks page 23.)

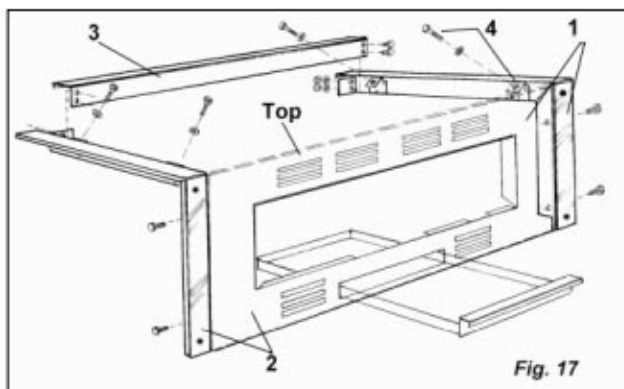

Note: Be certain that the gas pressure is between 6.5" and 7.5" water column. Excess gas pressure can cause warping and damage to grill head.

6. When finished connecting gas supply, slide grill all the way into to opening so that the "L" bracket face flanges fit snugly to your enclosure face. Drill a hole in the masonry to match up with the "L" bracket face flange holes and fasten with lag bolts (not supplied).

Do not build a shelf below the bottom of the grill. The grill requires an open area for proper ventilation and service access.

7. Install the pre-assembled door kit by securing with a suitable fastening method. (Anchors and/or screws not included.)

When you complete the mount assembly go to the appropriate Grill Assembly Section and finish assembling the grill head.

JNR & WNK Assembly Instructions

CARTON CONTENTS

Please check to be sure that all parts are included before proceeding with assembly. Contact your local dealer if any parts are missing.

Note: The grill is partially assembled. The Burner, Spider Guards, Venturis, Ignitor Collector Box are installed. Also, for LP units the Gaslow Regulator and Hose are installed.

MODEL JNR GRILL

<u>Parts</u>	<u>Quantity</u>
Top Casting (Grill Lid)	1
Bottom Casting (Grill Head)	1
Sta-Kool Handle	1
Handle End Caps	2
Warming Rack	1
Bottom Grate	1
Stainless Steel Cooking Grid (SearMagic 2)	1
Control Panel Brackets	2
Heat Shield	1
Grease Cup Holder	1
Control Panel Assembly	1
Valve Control Knobs	2
Ignitor Button	1
AAA Battery	1
Side Shelf	1
Side Shelf Bracket	1
Venturi Tube Cleaning Brush	1
Bag of Briquettes (53 pieces)	1
Lid Mounted Heat Indicator	1
Forked Grid Cleaning Tool (SearMagic Only)	1
<u>Hardware</u>	<u>Quantity</u>
Connecting Wire for Ignitor	1
1/4-20 x 1 1/2" Rd. Hd. Sltd. Bolt	4
1/4-20 x 1/2" Rd. Hd. Sltd. Bolt	2
1/4-20 x 3/4" Hex head Bolts	3
1/4-20 x 1" Hex head Bolts	4
1/4-20 x 1 1/2" Hex Head Bolt	2
1/4-20 KEP Nut	11
Hitch Pin for Lid	2

MODEL WNK GRILL

<u>Parts</u>	<u>Quantity</u>
Top Casting (Grill Lid)	1
Bottom Casting (Grill Head)	1
Sta-Kool Handle	1
Handle End Caps	2
Warming Rack	1
Bottom Grate	1
Stainless Steel Cooking Grids (SearMagic 3)	2
Control Panel Brackets	2
Heat Shield	1
Grease Cup Holder	1
Control Panel Assembly	1
Valve Control Knobs	2
Ignitor Button	1
AAA Battery	1
Side Shelf	2
Side Shelf Bracket	2
Venturi Tube Cleaning Brush	1
Bag of Briquettes (67 Pieces)	1
Lid Mounted Heat Indicator	1
Forked Grid Cleaning Tool (SearMagic Only)	1
<u>Hardware</u>	<u>Quantity</u>
Connecting Wire for Ignitor	1
1/4-20 x 1 1/2" Rd. Hd. Sltd. Bolt	6
1/4-20 x 1/2" Rd. Hd. Sltd. Bolt	2
1/4-20 x 3/4" Hex head Bolts	3
1/4-20 x 1" Hex head Bolts	8
1/4-20 x 1 1/2" Hex Head Bolt	2
1/4-20 KEP Nut	13
Hitch Pin for Lid	2

JNR & WNK Assembly Instructions

Grill Head Assembly Instructions

- The grill head bottom must be attached to the mounting before starting.
- It is easiest to work with the grill in the upright position.
- The difference between the JNR and the WNK is the WNK is larger, has two side shelves and the warming rack fastens differently.
- Leak test all gas connections before using.
- Caution: Combustible material should never be within 18 inches of the bottom, back or sides of your MHP Gas Barbecue Grill.

View of JNR & WNK Grill Head Components

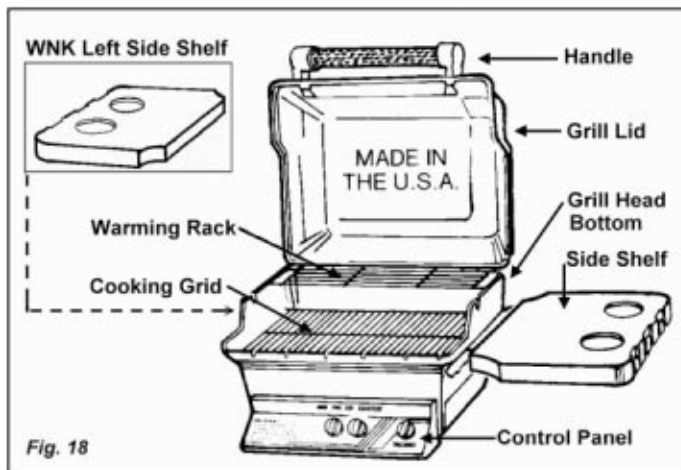

Step 1: Control Panel & Heat Shield

A. Attaching the Heat Shield and Control Panel Assembly (Fig. 19)

1. Attach the complete control panel assembly to the front of the grill head with 1/4—20 Keps nuts.
2. Leave the (2) nuts holding the heat shield on, to serve as spacer nuts.
3. Make sure the valve orifices on the control panel aligns with the burner venturi correctly and that the venturi tubes go over the valve orifices at least 1/4" to 1/2" (see fig. 22 on page 16).

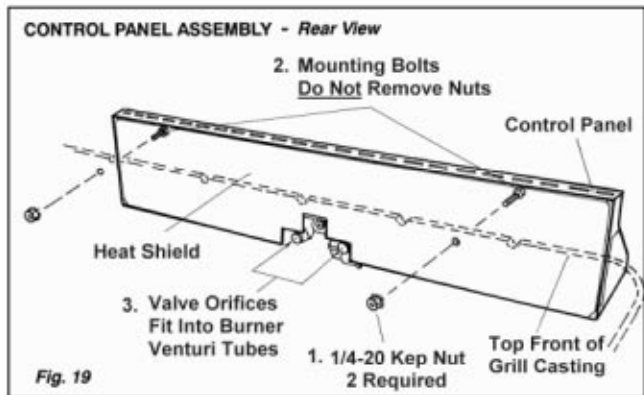

B. Connecting the Control Panel Support Brackets (Fig. 20)

1. Two support brackets are connected beneath the control panel to the grill head for added support. Push a 1/4 - 20 x 1 1/4" Phillips head bolt through the grill head from the inside.
2. Slip the support bracket in position, fasten with a 1/4 - 20 Keps nut.
3. Attach the control panel to the support bracket by pushing up a 1/4 - 20 x 1/2" Phillips head bolt through the support bracket and through the lower lip of the control panel, fasten with a 1/4 - 20 Keps nut.

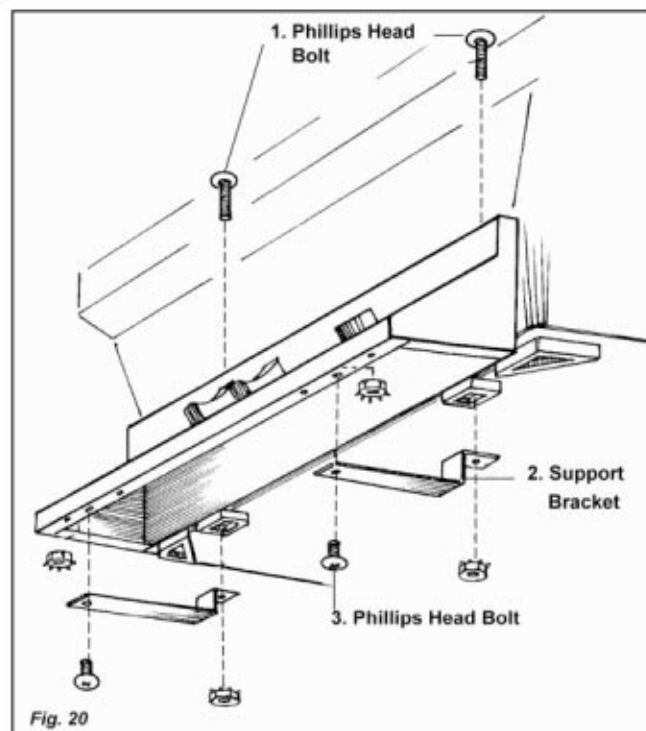

JNR & WNK Assembly Instructions

C. Ignitor Wire Connection (Fig. 21)

1. Tip the grill on its back (or upside down) and attach the control panel ignitor wire to the terminal sticking out from the bottom of the grill. **Be careful not to crack the delicate porcelain insulator.**

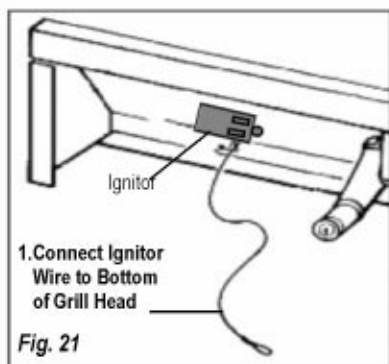

D. Orifice Engagement (Fig. 22)

At the top end of each valve there is a tiny gas opening known as the orifice. Gas exits the orifice and enters a venturi where it mixes with air coming in from the side air shutter. The proper mixture of air and gas produces a clean blue flame at the burner.

Make sure the valve orifice on the control panel aligns with the burner venturi tube correctly. The orifice should fit into the venturi tube $\frac{1}{4}$ " to $\frac{1}{2}$ " inches as shown below.

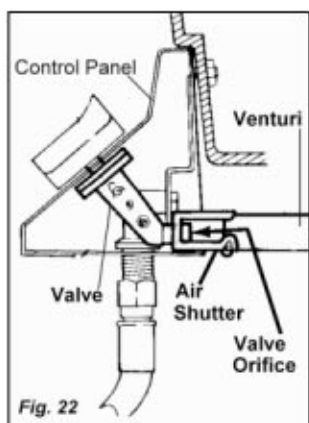

WARNING! Always check the alignment of the orifice and the venturi whenever the grill has been moved. Make sure that the orifice fits into the venturi tube $\frac{1}{4}$ " to $\frac{1}{2}$ ". Failure to make this connection may cause fire and result in serious body injury or damage to your grill.

Step 2: Connect the gas supply line (Fig. 23)

A. For LP-Gas Tank and LP Cart Models:

1. Pass the Gaslow Regulator Hose through the hose clamp ring and screw the ring to the front of the left leg.
2. Connect the regulator end of the hose to the LP-Gas Tank. **Tighten securely and leak test both connections. See Leak Testing on page 23.**

B. For Natural Gas Carts Using 12 foot Hose:

Connect one end of the supplied 12 foot hose to the grill valve connection behind the control panel. Then, connect the quick disconnect valve on the hose to the gas supply line connection. **Tighten securely and leak test both connections. See Leak Testing on page 23.**

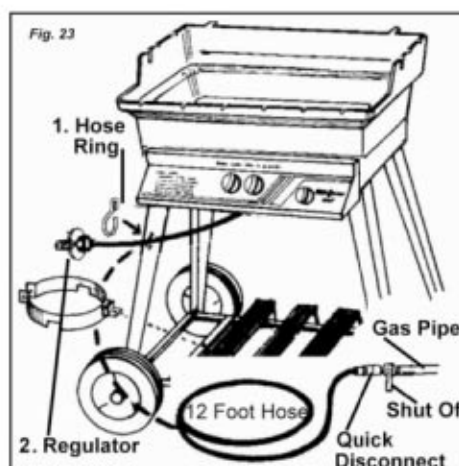

Do not allow the gas hose to come in contact with the bottom of the grill head.

C. For Deck/Patio & In-Ground Mounts Using 30" Flexible tubing. (Fig. 24)

Connect the 30" flexible tube to the incoming gas supply using a $\frac{3}{8}$ " flare coupling (not supplied). Attach the other end to the grill valve connection behind the control panel. To tighten securely use two wrenches. Hold valve joint with one wrench and tighten the hose fitting with second wrench. **After Tighten leak test both connections. See Leak Testing on page 23.**

Do not use compound or Teflon tape on flare fittings.

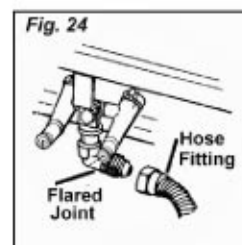

JNR & WNK Assembly Instructions

Step 2: Continued

D. Column Mount Gas Connections

Aluminum and Stainless Column mounts:

The supply line connection pass beneath the heat shield and through the front slot with the protected edge and attaches to the valve.

Don't forget to attach the front Access Panel to the Column. (Fig. 25)



Fig. 25

LP Propane for portable base and deck/patio mounts:

The hose connection from the Gaslow/Regulator passes out the front access opening; resting the protected slot edge beneath the control panel. The LP tank locking bar will press against the tank as it is lowered into place to prevent tank movement.

(Fig. 26)

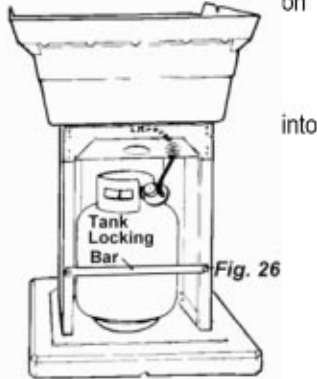

Fig. 26

Natural gas for deck/patio mount

The gas line enters at the rear of the base curving up through the base opening. The stainless steel flexible tubing line must be connected to the incoming gas line using a 3/8" flare coupling (not supplied by MHP). The flexible tubing then passes beneath the heat shield and through the front access opening and attaches to the control valve. (Fig. 27)

See page 26 for tubing bending instructions.

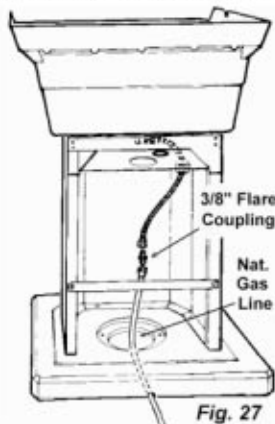

Fig. 27

Tighten all gas connections securely and leak test both ends. See Leak Testing on page 23.

Natural gas hose for portable base mount

The natural gas cart uses a 12 foot hose with a quick disconnect (supplied). The hose passes beneath the heat shield through the front access opening and connects directly to the control valve. The quick disconnect end attaches to the gas supply line at the shut-off valve.

(Fig. 28)

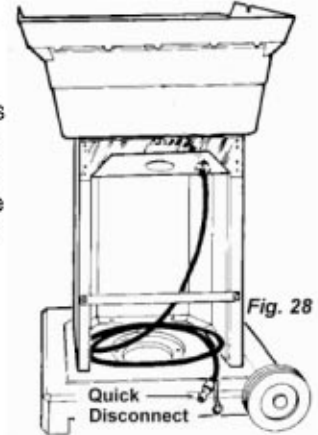

Fig. 28

Step 3: Attaching the Side Shelf (Fig. 29)

1. Turn NuStone Shelf upside down, noting the hole location of the (2) Brass Treaded Inserts.

2. Lay Aluminum side shelf bracket onto shelf and mount NuStone Shelf with supplied 1/4-20 x 1 1/4" Phillips head bolt and Lock washers.

Do not over tighten.

3. Attach the entire unit to the grill head by inserting two 1/420 x 1 1/2" Rd. Hd. Sld screws. Insert bolt through the holes located on either the right or left side of the bottom grill head, fasten with a 1/420 Kep nut.

(Note: Repeat steps 1 and 3 to attach the WNK model second side shelf.)

Please See Page 20 For Attaching the Stainless Steel Fold Down Shelves.

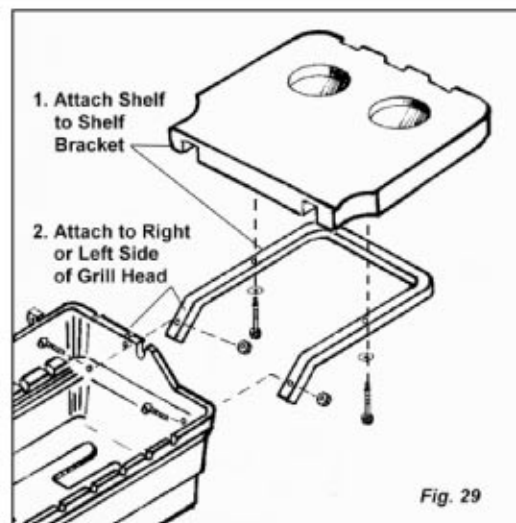
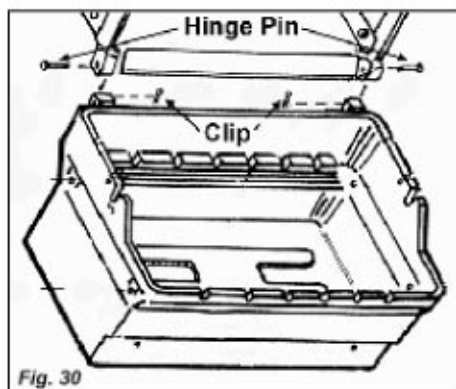

Fig. 29

JNR & WNK Assembly Instructions

Step 4: Attaching the Grill Lid (Fig. 30)

1. Attach the grill lid to the grill head bottom using the two Hinge Pins and Hinge Clips.



Step 5: Connect the Handle (Fig. 31)

1. Attach the handle to the grill lid using two 1/4 - 20 x 1 1/2" Hex bolts with Kep nuts. Graphite Gaskets are positioned between the end caps and grill lid as shown in fig. 31. Use two 7/16" wrenches, one to hold the bolt head and one to tighten the nut.

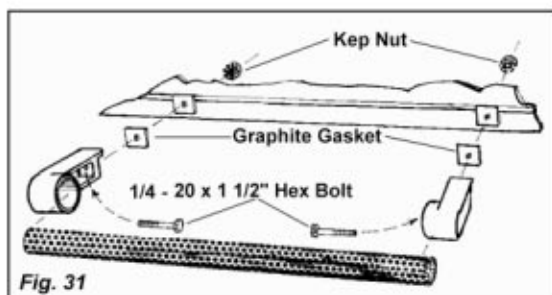

Step 6: Grates, Briquettes and Cooking Grids (Fig. 32)

1. Place the one piece BriquetteGrate on the shelf edge just above the burner.
2. Carefully place the Porcelain Briquettes on the grate in the pattern shown. Use only one layer.
3. Place the two Cooking Grids above the Briquette Grate

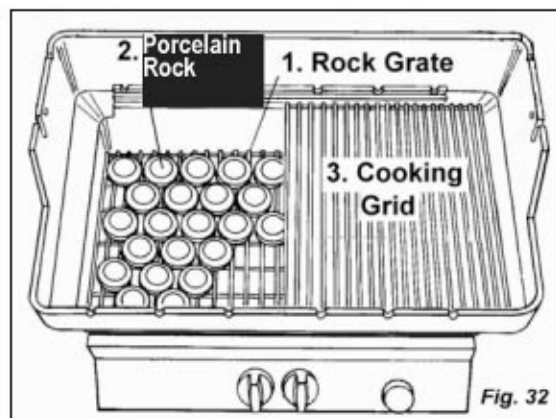

Step 7: Warming Rack

1. The JNR Warming Rack rests in the notches on the top edge of the grill head bottom. (Fig. 33)

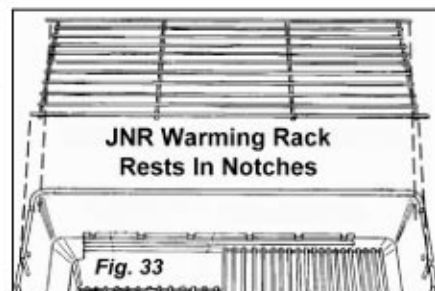

2. The WNK and TJK swing-away Warming Rack connects to the grill lid and the grill head bottom. First, insert the right Top and Bottom Rods into their respective mounting holes on right side of the grill lid and grill head bottom. Then slide the RACK to your left, positioning the left Top and Bottom Rods into their respective mounting holes simultaneously. The Lower Right Rod End can then be "popped" into place by flexing it inward. (Fig. 34)

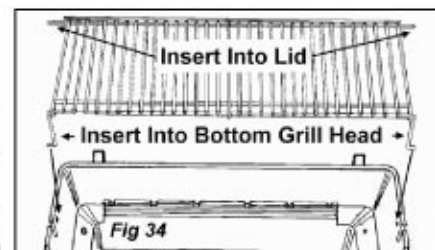

3. The SearMagic Warming Rack drops onto the top edge of the grill head bottom. the warming rack bracket is positioned between the hinges of the grill head bottom inside back wall. (Fig. 35)

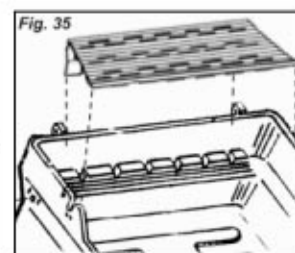

Before using your grill, leak test all gas line connections. And follow the lighting instructions. See page 23.

TJK Assembly Instructions

CARTON CONTENTS

Please check to be sure that all parts are included before proceeding with assembly. Contact your local dealer if any parts are missing.

Note: The grill is partially assembled. The Burner, Spider Guards, Venturis, Ignitor Collector Box and the Stainless Steel Handle are installed. Also, for LP units the Gaslow Regulator and Hose are installed.

MODEL TJK Grill

<u>Parts</u>	<u>Quantity</u>
Top Lid Assembly	1
Bottom Casting (Grill Head)	1
Warming Rack	1
Bottom Grate	1
Stainless Steel Cooking Grids (SearMagic 3)	2
Control Panel Brackets	2
Heat Shield	1
Grease Cup Holder	1
Control Panel Assembly	1
Valve Control Knobs	2
Ignitor Button	1
Stainless Steel Side Shelf Kit	2
Side Shelf Bracket	2
Venturi Tube Cleaning Brush	1
Bag of Briquettes (67 pieces)	1
Lid Mounted Heat Indicator	1
AAA Battery	1
Forked Grid Cleaning Tool (SearMagic Only)	1

MODEL TJK GRILL

<u>Hardware</u>	<u>Quantity</u>
Connecting Wire for Ignitor	1
1/4-20 x 1 1/2" Rd. Hd. Sltd. Bolt	2
1/4-20 x 1 1/4" Rd. Hd. Sltd. Bolt	4
10-24 x 1 1/4" Rd. Hd. Bolt	8
1/4-20 x 3/4" Hex Head Bolt	3
1/4-20 x 1/2" Rd. Hd. Sltd. Bolt	2
10-24 KEP Nut	8
1/4-20 KEP Nut	11
Lid Pivot Pin	2

Grill Head Assembly Instructions

- *The grill head bottom must be attached to the mount before starting.*
- *It is easiest to work with the grill in the upright position.*
- *Leak test all gas connections before using.*
- *Caution: Combustible material should never be within 18 inches of the bottom, back or sides of your MHP Gas Barbecue Grill.*

IMPORTANT: Most of the TJK Model major component assembly is the same as the JNR/WNK Models. Please refer to the JNR/WNK assembly instructions as indicated.

Step 1: Control Panel & Heat Shield

(See JNR/WNK instructions on page 15, Fig. 19 & 20)

Step 2: Connect The Gas Supply Line

(See JNR/WNK instructions, item D on page 17, Figs. 25-28)



Continue on following page. →

TJK Assembly Instructions

Fold Down Shelf Parts

4 ea 1/4 x 2 0 x 3/4B olts



4 ea 1/4 x 20 Kep Nuts



4 ea 10 x 24 Nylock Nuts



2 ea Right Brackets



2 ea Left Brackets



2 ea Shelves

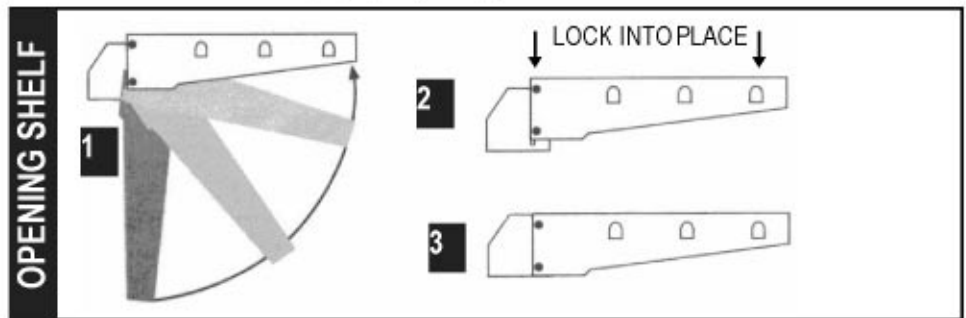
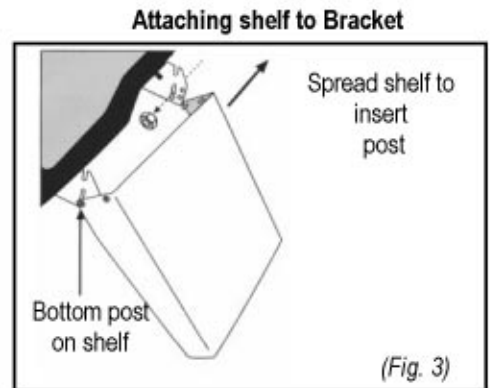
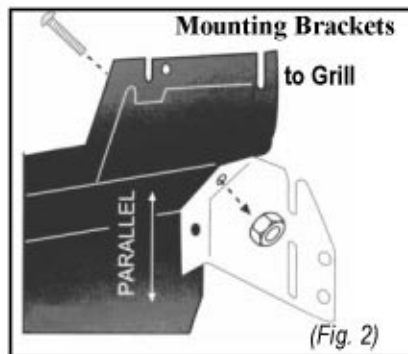

STEP 1

MOUNTING BRACKET TO GRILL (Fig. 1 and 2)

Attach Brackets to grill using **bolts** and **kep nuts** (1 bolt per bracket). Tighten nuts while making sure brackets are parallel with grill.

STEP 2

ATTACHING SHELF TO BRACKET (Fig. 3)

Place the left bottom **shelf** post into the left bottom **bracket** slot. Gently spread the **shelf** apart to insert the right bottom **shelf** post into the right bottom **bracket** slot. Secure bottom posts with **Nylock Nut**—making sure nuts are snug but **don not** restrict movement of folding and unfolding of the shelf.

Note: Top posts on shelf do **NOT** use nuts.

Side View of Grill

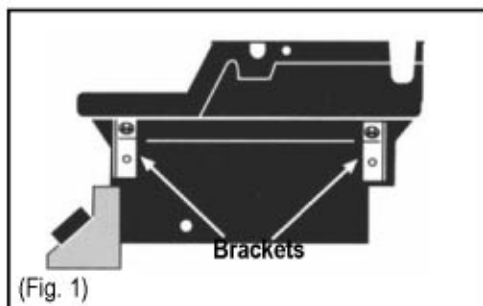

Step 4: Attaching the Grill Lid

(See JNRWNK instructions on page 18, Fig. 30.)

Step 5: Grates, Briquettes and Cooking Grids

(See JNRWNK instructions on page 18, Fig. 32)

Step 6: Warming Rack (Fig. 38 & 39)

1. The Warming Rack connects to the grill lid and the grill head bottom. First, insert the right Top and Bottom Rods into their respective mounting holes on right side of the grill lid and grill head bottom. Then slide the RACK to your left, positioning the left Top and Bottom Rods into their respective mounting holes simultaneously. The Lower Right Rod End can then be "popped" into place by flexing it inward.

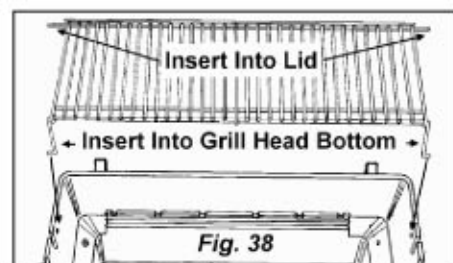

2. The SearMagic Warming Rack drops onto the top edge of the grill head bottom. The warming rack bracket is positioned between the hinges of the grill head bottom inside back wall.

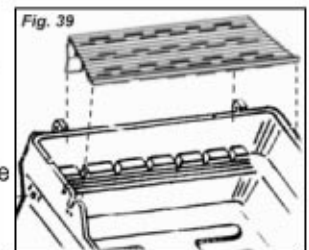

Before using your grill, leak test all gas line connections. And follow the lighting instructions. See page 23.

WRG4 and TRG2 Assembly Instructions

SUPPLEMENTARY ASSEMBLY INSTRUCTIONS FOR COLUMN, PATIO BASE AND IN-GROUND POST

Prior to assembling your WRG4 or TRG2 grill with the **Optimum Console, Patio Base or In-Ground Post**, the following instructions must be followed to gain access to the mounting holes in the grill head bottom. Assembly of grills with the **WCP** or **WCN** base begins on page 6 of the Owner's Manual.

1. With a slotted screwdriver or 1/4" wrench, remove the rear mounting screw on the back of the burner venturi where it meets the grill head bottom. Use a 11/32" or adjustable wrench on the nut on the outside of the grill head bottom (Fig. 1).

CAUTION: DO NOT BREAK CERAMIC ELECTRODE WHEN REMOVING OR REINSTALLING BURNERS!

2. Under the control panel, remove the screw on the burner where it meets the orifice. Use a 1/4" wrench or a slotted screwdriver for this. (Fig. 2).

3. Once these screws are removed from the burner, carefully lift each out of the grill. For the Column, the right and left infrared burners need to be removed. For the MPB Patio Base and the MPP In-Ground Post, only the center infrared burner needs to be removed.
4. Be careful not to damage the igniter when removing the burner.
5. For mounting the grill head on the Column, follow the instructions on page 10 and 11 of the MHP Owner's Manual.

6. For mounting the grill head on the MPB Deck/Patio Base, follow the instructions on page 8 of the MHP Owner's Manual.

7. For mounting the grill head on the MPP In-Ground Post, follow the instructions on page 9 of the MHP Owner's Manual.

8. After the grill head is mounted, reinstall the burners into the grill head bottom. Insert the venturi tube through the opening at the front of the grill head, and over the orifice holder. Make sure the burner venturi is fully engaged over the orifice holder, then tighten the venturi set screw securely.

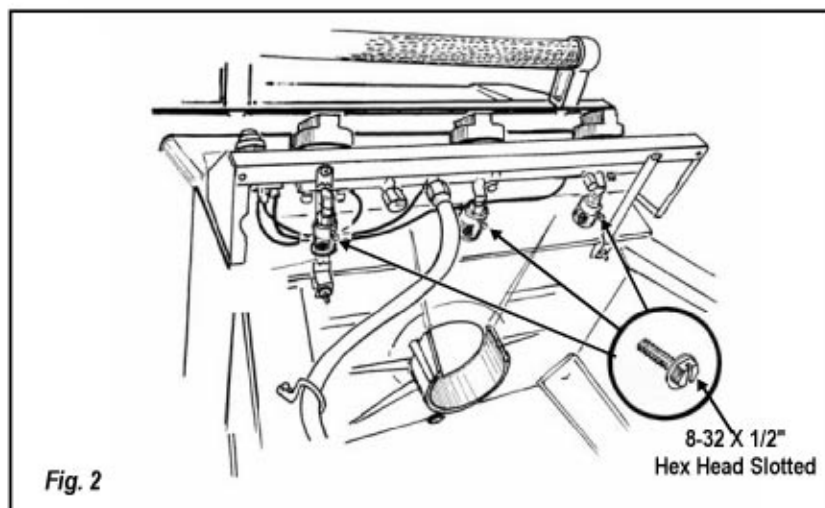
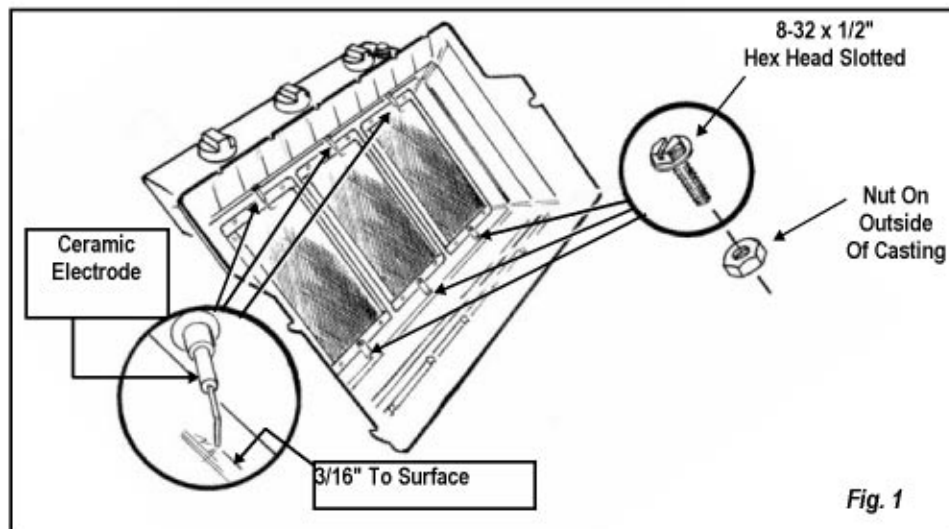

INFRARED GRILL LIGHTING INSTRUCTIONS

1. Always open the hood before lighting.
2. Keep your head and body at least 1 foot away when lighting the grill. Do not lean over an open grill.
3. Turn one burner on the "HIGH" position, and depress the electronic igniter until the burner lights.
4. Proceed to light the next burner in the same fashion.

Each burner needs to be lit independently. They will not light off of each other.

5. If the burners fail to light, turn control knobs off, wait 5 minutes for gas to clear and try lighting again.
6. If the igniter doesn't spark, check the gap between the wire probe burner screen. It should be approximately 3/16 inches wide. If it is too small, the spark may be inefficient. Gently readjust the wire probe as needed. If the gap is normal, check the wire connections at the spark

7. If the igniter still doesn't work, try replacing the battery. Remove the collar around the igniter button by turning it counter-clockwise. Replace the AAA battery, "+" side first.
8. If ignition does not occur after replacing battery in 5 seconds, turn burner control knob OFF, wait 5 minutes, and repeat the lighting procedure. If the ignition system is not working properly, the burners may be ignited manually. **FOR MANUAL LIGHTING:** The wire match holder (supplied with grill) may be used to hold two or three paper (safety) matches or a standard wooden match. For lighting the right, center and left burners, the lighted match(es) may be inserted between the opening on the cooking grid and held above the burner for lighting.
9. After grilling, turn each burner control knobs to OFF position. "TURN OFF LP supply at cylinder when appliance is not in use". **DO NOT** store extra cylinders under grill.

INFRARED COOKING TIPS

1. Infrared gas grills get very hot. **Do not leave food unattended on the grill for any length of time.**
2. Estimate cooking times to be 30% to 50% less than a conventional grill.
3. Always thaw food thoroughly before cooking to achieve better, more predictable results.
4. Always use long handled grill tools for grilling. A grilling mitt may be useful for handling hot items.
5. The use of a fork is not recommended for grilling on your new MHP grill. A fork may mar the surface of the cooking grids. Piercing foods while cooking will allow the juices to escape, causing the finished product to be drier than may be desired.
6. To minimize flare-up, trim fat from meats or remove skin from poultry.
7. If a flare-up occurs, don't try to control it with water. Water can cause burner damage. Instead, move the food to another part of the grill, lower the heat setting or place food on the Secondary Cooking Surface.

Burner Failure Caused By Water Damage Is Not Covered Under Warranty.

8. Cooking can be done with the hood opened or closed. With the hood open, the heat will be less intense with less flavor. With the hood closed, the heat will be more intense with an increase in the smoke flavor.
9. Allow the grill to heat up for 5 minutes on high before cooking.
10. Place the food on the SearMagic® cooking grids - while the grill is on high—to sear the food thoroughly. Searing is the key to locking in the juices for that delicious grilled flavor.
11. After searing for 2-3 minutes per side, lower the temperature to finish cooking the food as desired.
12. The SearMagic® cooking grids allow for greater versatility when grilling. Chicken breasts, steaks, pork chops or hamburgers can be seared over the ribbed side at a higher temperature. Delicate foods like seafood and vegetables can be cooked over a lower temperature with the smooth side up. This can be done over each of the 3 burners independently, so be as creative as you want to be!
13. The Secondary Cooking Surface is more than just a warming rack. Very delicate items, such as stuffed vegetables, sausages and delicate fish can be grilled, even with the intense heat that infrared burners provide.
14. Never cook over an unlit infrared burner. The drippings could cause the burner to crack when relit. Always use a drip pan to protect the unlit burner when cooking indirectly.

Burner Failure Caused By Cooking Over An Unlit, Unprotected Burner Is Not Covered Under Warranty.

15. To clean the grill after cooking, burn all 3 burners on high for at least 5 minutes with the hood closed. With the grill still

INFRARED CARE AND MAINTENANCE

1. After each use, close the lid and turn the burners to "High" for 5 minutes. This will burn off any food drippings and enhance the grill's performance and increase the burner longevity.
2. Never use water or liquid chemicals to clean the ceramic burners. Burners may be damaged.

Burner failure caused by improper care and Maintenance is not covered under warranty.

3. If the burner develops ash over the surface, clean it gently with a vacuum cleaner. Use a brush attachment so as not to damage the burner.

4. If the burners should get wet, it is important to dry it out completely before attempting to use the grill. First remove the affected burner. Then, turn the burner(s) upside down to allow the water to drain out. Let the burner dry overnight before reinstalling into the grill.
5. Never let anything heavy, hard or sharp fall onto the burner. The ceramic is very fragile and can easily be damaged.

WHRG4 and THRG2 Assembly Instructions

The WHRG4 and THRG2 feature 1 Infrared Burner and 2 Cast Stainless Steel Burners combined with our revolutionary SearMagi® cooking system. This cooking combination provides one of the most versatile, reliable and intensely heated grills in the industry. Now you can cook items at a Lower Temperature over the cast stainless steel burners cooking area, with our Flavor Master Porcelain Briquettes, while Searing over the Infrared Zone.

SUPPLEMENTARY ASSEMBLY INSTRUCTIONS FOR COLUMN, PATIO BASE AND INGROUND POST

Prior to assembling your WHRG4 or THRG2 grill with the **Column, Patio Base or In-Ground Post**, the following instructions must be followed to gain access to the mounting holes in the grill head bottom. Assembly of grills with the **WCP or WCN** base begins on page 6 of the Owner's Manual.

1. With a slotted screwdriver or 1/4" wrench, remove the rear mounting screw on the back of the left and right burner where they meet the grill head bottom. Use a 11/32" or adjustable wrench on the nut on the outside of the grill head bottom (Fig. 1).

CAUTION: DO NOT BREAK CERAMIC ELECTRODE WHEN REMOVING OR REINSTALLING BURNERS!

2. Under the control panel, remove the screw on the burner where it meets the orifice. Use a 1/4" wrench or a slotted screwdriver for this. (Fig. 2).

3. Once these screws are removed from the burner, carefully lift each out of the grill. For the Column, the right and left burners need to be removed. For the MPB Patio Base and the MPP In-Ground Post, only the center burner needs to be removed.

4. Be careful not to damage the igniter when removing the burner.

5. For mounting the grill head on the Column, follow the instructions on page 10 and 11 of the MHP Owner's Manual.

6. For mounting the grill head on the MPB Deck/Patio Base follow the instructions on page 8 of the MHP Owner's Manual.

7. For mounting the grill head on the MPP InGround Post, follow the instructions on page 9 of the MHP Owner's Manual.

8. After the grill head is mounted, reinstall the burners into the grill head bottom. Insert the venturi tube through the opening at the front of the grill head, and over the orifice holder. Make sure the burner venturi is fully engaged over the orifice holder, then tighten the venturiset screw securely.

9. Place the Briquette Grate on the shelf edge just above the 2Oval Cast Stainless Steel Burners. Fig. 3

10. Carefully place the 46 Porcelain Briquettes on the grate in the pattern shown. Fig. 3

11. Place the SearMagic Cooking Grids above the Porcelain Briquettes and Infrared Burner.

12. The Warming Rack drops onto the top edge of the grill head bottom. (see Fig. 35 page 18)

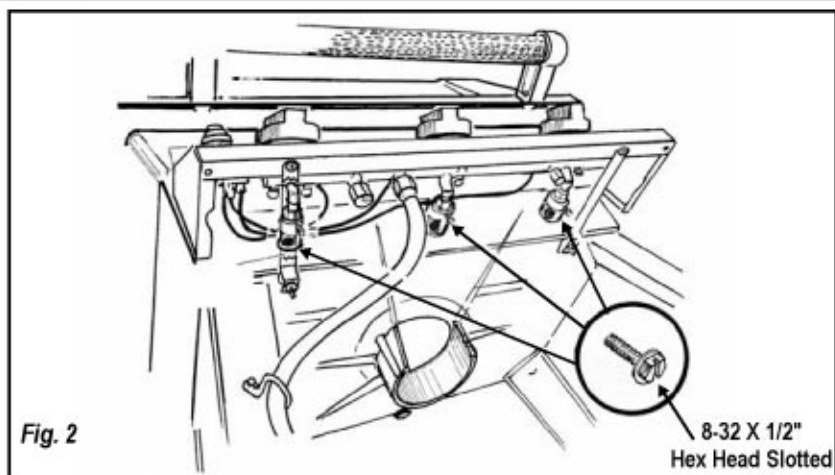
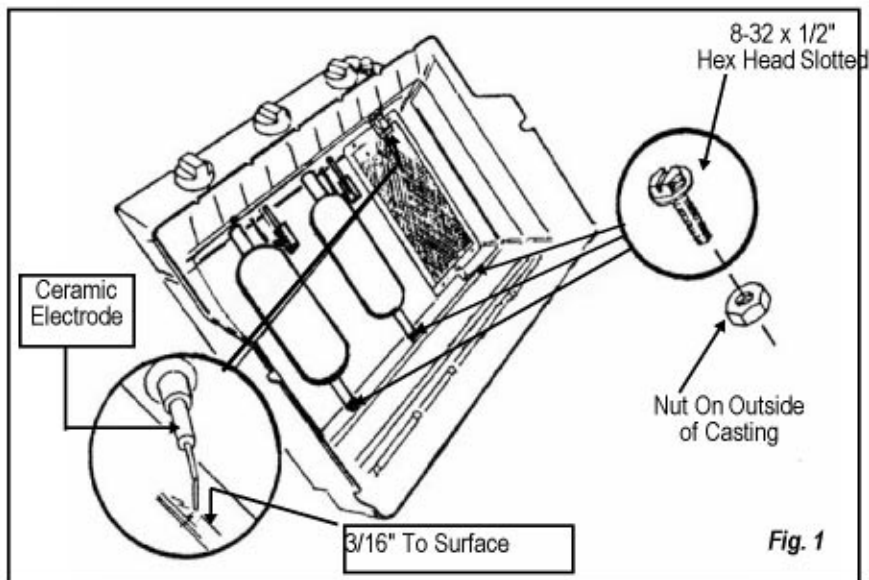

HYBRID GRILL LIGHTING INSTRUCTIONS

1. Always open the hood before lighting.
2. Keep your head and body at least 1 foot away when lighting the grill. Do not lean over an open grill.
3. Turn one burner on the "HIGH" position, and depress the electronic igniter until the burner lights.
4. Proceed to light the next burner in the same fashion.

Each burner needs to be lit independently. They will not light off of each other.

5. If the burners fail to light, turn control knobs off, wait 5 minutes for gas to clear and try lighting again.
6. If the igniter doesn't spark, check the gap between the wire probe burner screen. It should be approximately 3/16 inches wide. If it is too small, the spark may be inefficient. Gently readjust the wire probe as needed. If the gap is normal, check the wire connections at the spark module and igniter probes, located underneath the control panel.

7. If the igniter still doesn't work, try replacing the battery. Remove the collar around the igniter button by turning it counter-clockwise. Replace the AAA battery, "+" side first.

8. If ignition does not occur after replacing battery in 5 seconds, turn burner control knob OFF, wait 5 minutes, and repeat the lighting procedure. If the ignition system is not working properly, the burners may be ignited manually. **FOR MANUAL LIGHTING:** The wire match holder (supplied with grill) may be used to hold two or three paper (safety) matches or a standard wooden match. To light the right burner insert the lighted match(es) through the lower right side match hole and turn on the RIGHT burner control knob to HIGH setting. For lighting the center and left burners, the lighted match(es) may be inserted between the opening on the cooking grid and held beside the center and above the left Infrared burner for lighting.

9. After grilling, turn each burner control knobs to OFF position. "TURN OFF LP supply at cylinder when appliance is not in use". **DO NOT** store extra cylinders under grill.

NOTE: Please refer to page 22 for Infrared Cooking Tips, Infrared Burner Care and Maintenance.

GRILL HEAD AND MOUNTING AT A GLANCE



Gas & LP Tank Connections

GAS & LP CYLINDER

Check Local Codes

Consult your local LP dealer or Natural Gas Company for recommended installation procedures and regulations. In the absence of local codes, installation must conform to the National Fuel Gas Code, ANSI Z223.1 or CAN/CGA-B149.1 Natural Gas Installation Code or CAN/CGA-B149.2, Propane Installation Code.

Natural Gas Models

The grill is designed to operate on Natural Gas at a pressure of 7" water column (W.C.) [1.75 kPa]. Check with your gas utility for local gas pressure. Use of your gas grill at pressures other than approximate 7" WC could affect the performance of your grill.

Natural Gas Hose & Inspection

A single hose of not more than 12 feet long (3.6 meters) is supplied with the cart-styled models.

- Check the hose before each use at places where there could be extra bending, such as near the gas supply quick-disconnect coupling and at the grill valve connection. Look for cracking, cuts or heat damage. Check the entire length for cracking and excessive wear.
- To replace the hose, turn off gas supply at valve. Release the quick-disconnect coupling. Using a wrench, disconnect hose from grill valve connection under the control panel, and clean threads.
- Replace only with an identical hose from the manufacturer or an authorized dealer. **Do not use pipe joint compound on the flared fitting at the control panel grill valve connection.**

LP Gas Models

The Grill using a **Type I** LP cylinder includes the Gaslow Regulator that incorporates an industry exclusive Leak Detector and Fuel Supply Indicator. Any replacement pressure regulator or hose assembly must meet or exceed the specifications of the Gaslow Regulator.

DO NOT CONNECT THE GRILL TO AN LPGAS CYLINDER GREATER THAN 20 LB. CAPACITY.

LP Gas Cylinder Requirements: (The LP-Gas Cylinder is not supplied with your MHP Grill.)

- The LP cylinder should be equipped with an OPD (Overflow Prevention Device) and a QCC! Or Type 1 (CGA810) cylinder connection. This cylinder connection is compatible with the grill connection. OPD is an internal mechanical device that limits the amount of liquid propane and prevents overfilling the LP cylinder. The correct filling methods for the filling of your cylinder are by weight or volume, as described in NFPA 58. Please make sure your LP dealer fills your LP cylinder by weight or volume. Ask your LP dealer to read purging and filling instructions on the LP cylinder before attempting to fill.
- All LP cylinders supply systems must include a collar to protect the cylinder valve.
- The LP cylinder must be a 20-LB size (18 1/4" high, 12 1/4" in diameter).
- The LP cylinder must be constructed and marked in accordance with the specifications for LP-gas cylinders of the U.S. Department of Transportation (D.O.T.). In Canada, gas cylinders must meet Canadian LP Gas Tank Specification Code, National Standard of Canada, CAN/CSA-B339, Spheres and Tubes for the Transportation of Dangerous Goods and Commission.
- Be sure your LP cylinder has a D.O.T. certification and has been tested within five years. This information is usually marked on the protective collar.



WARNING: If you use an LP tank exchange service, be sure that the exchanged tank is equipped with an OPD. If there is not an LP tank available for exchange equipped with an OPD, we recommend that you have your LP tank filled by an authorized LP dealer.

DANGER

Do not use an open flame to check for gas leaks. Be sure there are no sparks or open flames in the immediate area while you check for leaks. Sparks or flames will result in a fire or explosion which can cause serious bodily injury or death, and damage to property.

Gas & LP Tank Connections

CONNECTING THE LP CYLINDER (Fig. 40)

1. Slip the LP cylinder into the grill LP Tank Mounting. Position the LP cylinder so that the tank valve receives the regulator without kinking or creating sharp bends in the hose. Secure the tank to the grill base. For cart base models fasten the mounting thumbscrew to secure the tank in place. The Optimum Console base models has the LP Tank Locking Bar to hold the LP Cylinder in place (**refer to mounting section for detail**).
2. The Gaslow Regulator has a large plastic nut - QCC-1 fitting - for hand tightening (no tools required) and a RIGHT HAND THREAD (turn clockwise). Connect the regulator to the cylinder by inserting the regulator nipple into the tank valve. Tighten the large plastic nut **CLOCKWISE** by hand until secure.

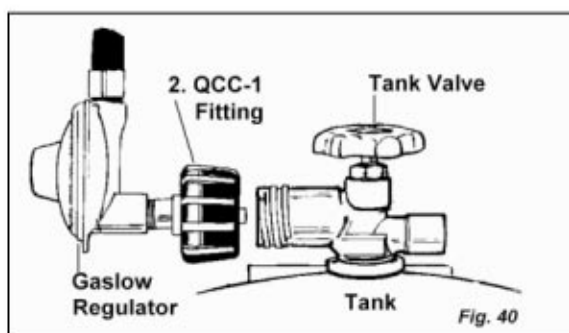

REMOVAL OF THE LP CYLINDER (Fig. 38)

1. Close the LP tank valve.
2. Unscrew the QCC-1 plastic nut **BY HAND** COUNTERCLOCKWISE (to the left).
3. Loosen the LP cylinder from the Tank Mounting
4. Lift cylinder off.

WARNING: If you exchange your LP cylinder, make sure you get a similar tank in return.

WARNING: Your exchanged LP cylinder must be equipped with a QCC-1 or type-1 valve and an OPD (Overflowing Prevention Device). Other LP cylinders may not be compatible with your grill connection.

LP-GAS CYLINDER FILLING & HANDLING

A qualified attendant, who fills the cylinder by weight, should fill your LP cylinder at an authorized LP gas dealer. Improper filling is dangerous.

- When transporting the LP cylinder be sure the plastic dust cover is in place over the valve. This keeps the valve threads free of dirt.
- Do not handle the cylinder roughly.
- Do not apply heat directly to the cylinder.

LP-GAS CYLINDER FILLING & HANDLING (Continued)

- Air must be removed from a new LP cylinder before the initial filling. Your LP dealer is equipped to do this.
- The cylinder supply system must be arranged for vapor withdrawal
- Always keep and store cylinders in an upright, secure position.
- Use this grill outdoors in a well-ventilated area. Do not use in a garage, building, or any other enclosed area.
- Storage of an outdoor cooking gas appliance indoors is permissible only the cylinder is disconnected and removed from the outdoor cooking gas appliance.
- If the outdoor cooking appliance is not in use, the gas must be turned off at the supply cylinder.
- Cylinders must be stored outdoors out of reach of children and must not be stored in a building, garage or any other enclosed area.

LP GAS CYLINDERS SAFE HANDLING TIPS

- Liquid propane (LP) gas is a petroleum product as are gasoline and natural gas. LP gas is a gas at regular temperatures and pressures. Under moderate pressure, inside a cylinder, LP gas is a liquid. As the pressure is released, the liquid readily vaporizes and becomes gas.
- LP gas has an odor similar to natural gas. Be aware of this odor.
- LP gas is heavier than air. Leaking gas collects in low areas and prevents dispersion.
- To fill, take the LP cylinder to your local authorized LP dealer, or look up "gas-propane" in the yellow pages to find authorized dealers.
- A new LP cylinder must be purged before the first filling. Your LP dealer is equipped to do this.
- An LP cylinder must be transported, installed and stored in an upright position.
- LP cylinders should not be handled roughly.
- Never store or transport an LP cylinder where the temperatures can reach 125 degrees. Never leave an LP cylinder in a car on a hot day.
- Always close the LP cylinder valve before disconnecting the tank or any other gas fitting.
- Always close the LP Cylinder valve after using grill.
- Do not use a damaged LP cylinder. Dented, rusty or a damaged LP cylinder valve may be hazardous and should be replaced with a new one immediately.

Never fill the LP cylinder beyond 80% full.
Do not store a spare LP gas cylinder under or near the grill.
If this information is not followed exactly, a fire causing death or serious injury may occur.

Leak Testing & Lighting Grill

Leak Testing

- ⚠ LEAK TEST ALL GAS CONNECTIONS BEFORE USING YOUR GRILL.
 - ⚠ DO NOT SMOKE WHILE LEAK TESTING.
 - ⚠ DO NOT LEAK TEST WITH A MATCH OR OPEN FLAME.
 - ⚠ DO NOT USE A GRILL THAT IS LEAKING GAS.
 - ⚠ YOU SHOULD TEST FOR GAS LEAKS EVERY TIME YOU DISCONNECT AND RECONNECT A GAS FITTING.
- PERFORM A LEAK TEST EVEN IF YOUR GRILL WAS DEALER OR STORE ASSEMBLED.
- ⚠ DO NOT IGNITE BURNERS WHEN LEAK TESTING.

LEAK TESTING

1. For LP models, leak test with a full propane cylinder.
2. For systems other than self-contained LP cylinders:
 - A. The grill and its individual shut-off valve must be disconnected from the gas supply piping systems during any pressure testing of that system at test pressures in excess of 1/2 psi (3.5 kPa).
 - B. The grill must be isolated from the gas supply piping system by closing its own manual shut off valve during any pressure testing of the gas supply piping system at pressures equal to or less than 1/2 psi (3.5 kPa).
3. Grill burner control valves should be turned off and the gas turned on at source.
4. Apply soap solution to all gas connections.
To make soap solution, mix together equal amounts of liquid detergent and water.
5. Soap bubbles will appear if there is a leak.
6. Tighten the connection to make proper seal. And recheck for soap bubbles.

If you cannot stop a gas leak by tightening, turn gas supply off.

- ⚠ Take leaking joint apart, clean it, reconnect and test again. If leak persists, contact the dealer or gas utility.

- ⚠ A gas system **MUST** be tested yearly, or whenever the LP cylinder or any other gas system part is replaced.

Lighting Your Grill

- ⚠ ALWAYS OPEN GRILL BEFORE LIGHTING THE BURNER.
- ⚠ DO NOT LEAN OVER AN OPEN GRILL. KEEP YOUR HEAD AND BODY AT LEAST ONE FOOT AWAY WHEN LIGHTING THE GRILL.
- ⚠ IF BURNER DOES NOT LIGHT, IMMEDIATELY TURN BURNER CONTROL KNOBS TO OFF. WAIT FIVE MINUTES TO LET GAS CLEAR BEFORE YOU TRY LIGHTING AGAIN.

LIGHTING

1. Open Lid. Examine the interior to be sure it appears normal.
2. Turn burner control knobs to OFF position.
3. Turn gas ON at LP tank or supply. **Wait 5 seconds for regulator to set itself.**
4. Turn either burner control knob to HIGH, press and hold the ignitor button until one half of the burner lights. Turn the other burner control knob to HIGH and the other half of the burner will light automatically.
5. Check that the burner is lit by looking through the match light hole on the lower right hand side. The burner flame should be a hard blue cone with a minimum amount of yellow flame, although some yellow dust flicks may occur.

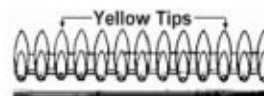

6. Close the grill lid and pre-heat the grill for five to ten minutes before cooking.

WARNING: If burner fails to light, turn control knobs OFF and wait five minutes for gas to clear and try lighting procedure again.

To light burner manually, use a paper book match or other hand held ignitor. Insert match through lower right side match hole. Turn on the **RIGHT** burner control knob to the high setting. Light burner.

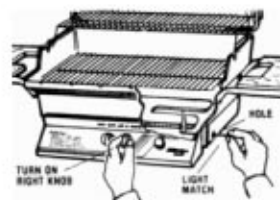

To Extinguish your grill: Turn each burner control knob to OFF position. Turn gas supply OFF at the source.

Maintenance

Annual Maintenance

After a period of nonuse or to keep your grill in top operating condition, you should perform the following maintenance procedures to keep the grill ready for instant use and for your safety.

- Do not obstruct the flow of combustion and ventilation air.
- Clean inside the grill head. Remove the burner/venturi assembly and cover the valve orifices with a piece of aluminum foil to keep out dirt. Brush inside bottom and sides with a stiff wire brush to remove built-up grease and debris. **Be careful not to damage the Ignitor or Collector Box.**
- Test the Ignitor for a good spark. (See Ignitor System in the General Maintenance section.)
- The stainless steel burner may be brushed lightly with a stiff laundry brush. Any clogged flame holes may be opened using a thin wire. Use the supplied venturi cleaning brush or a bottle brush, pipe cleaner to clean out the venturis. (See Flashback in General Maintenance.)
- Clean the Control Panel, Side Shelf Supports, Lid Handle Spacers, Lower Cart Frame, Posts with a mild detergent soap and warm water solution. For the Optimum Console use a mild detergent soap and water, Windex or a quality stainless steel cleaner such as MHP's Stainless Steel Cleaner (Part #SSC) to clean the column and grill lid facing. **Do Not Use cleaning agents such as bleach, powdered cleansers, steel wool pads or caustic solutions like oven cleaners because they will damage the surfaces.**
- Occasional white oxidation on the exterior of your grill head and lid may be washed off with mild soap and warm water.
- Severe weathering of the grill head and lid can be remedied by lightly sanding or rubbing with steel wool. Then it can be re-coated with a high quality heat resistant paint similar to MHP's BF-1 Paint, available in spray cans from your dealer.
- Inspect the hose and gas fittings. Remember to leak check every time you disconnect and reconnect a gas fitting.
- Keep the ventilation openings of the LP cylinder enclosure free and clear from debris.

Warning: Check the hose before each use of the grill for nicks, cracking, abrasions or cuts. If the hose is found to be damaged in any way, do not use the grill. Replace using only MHP authorized replacement hose.

General Maintenance

Flashback

In some areas of the country, spiders and other insects build nests, lay eggs and spin webs in the grill's venturi tube or valve orifice. This obstructs the full flow of gas to the burner. Some gas backs up resulting in a **"Flashback"** - a fire in the venturi behind the control panel which could cause serious bodily injury or damage to your grill.

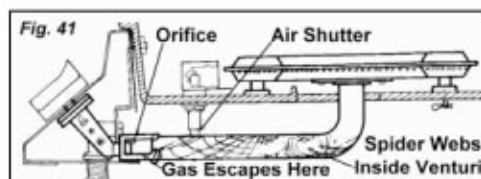

To remove spider webs and/or other obstructions, you must clean out the venturis. **This should be done routinely if the grill has sat idle for extended periods. Also, if you live in an area where spiders are plentiful, you should clean the venturis often, especially in the fall when there is an increase in egg sack production.**

To clean, be sure the grill is cold. Open lid and remove the cooking grids, the briquettes and the briquette grate.

1. Remove the burner clip holding the burner in place. (See Fig. 42)
2. Lift burner and venturi assembly out. With supplied cleaning brush, a pipe cleaner or a flexible wire, clean out the venturi tube.
3. Remove hex head orifice with a 3/8" wrench. Clean Orifice hole and inner part of the valve with a toothpick. Be careful not to enlarge the orifice hole.
4. Check orifice receptacle in valve body.

When finished cleaning reassemble the complete unit.

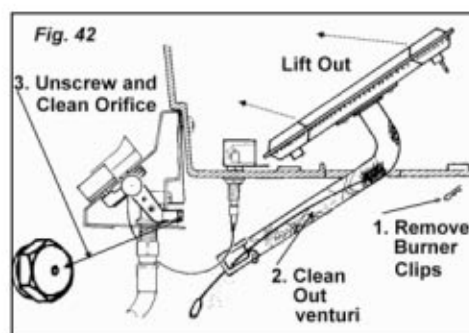

General Maintenance

Ignitor System

If you experience an occasional "No-spark-No light" condition here's a check list to troubleshoot the problem.

1. Inspection. WITH GAS OFF, position a mirror in front of the collector box and press ignitor button. Observe the condition of the spark. (Low light conditions are the best for seeing the spark.)

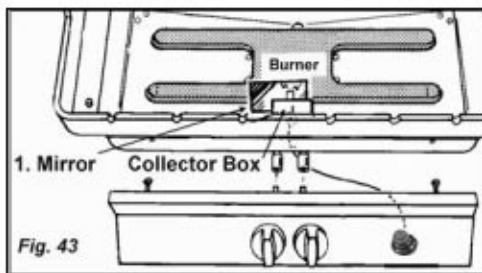

A. If there's a good spark, but the grill won't light, gas may not be flowing to the burner and into the collector box. The gas orifice or the venturi tube may be blocked. To clean, follow "Flashback" instructions.

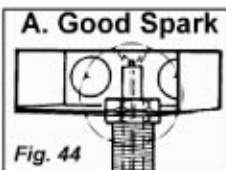

B. If a weak spark arcs down around the ceramic insulator, the insulator should be cleaned. The insulator has a coating of grease or it is wet. Use an old tooth brush to break up the conductive electric path.

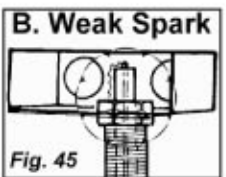

2. If there is no spark in the collector box.

A. Check the wire connections at the ignitor and electrode under the grill.

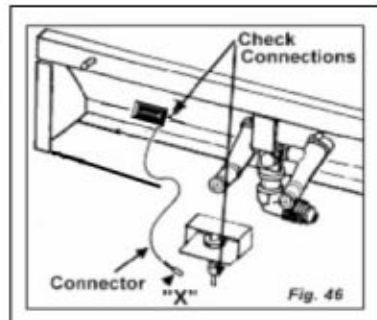

B. Check spark. Pull the connector wire from the collector box (see "X" Fig. 46). Bring wire to bottom or top of control panel, hold about 1/8" away and operate the ignitor. Check for spark. If there is **no spark**, first replace the battery, if there still isn't a spark, replace the electric ignitor. If there is a **spark** the Electric Ignitor is OK, but the Collector Box/Electrode assembly should be replaced (the ceramic insulator could be cracked).

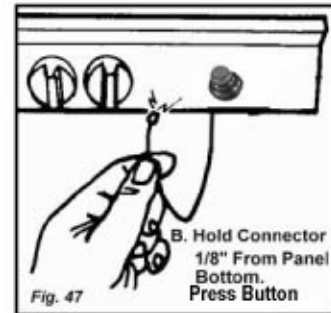

C. Make sure Ignitor Button module is tight on the control panel. If it is loose a good ground will not be attained.

Electrode Replacement or Adjustment

The electrode inside the collector box is pre-set for optimum spark. The tip is 1/8" from inside surface of the collector box. To replace, remove the collector box by loosening the large nut from the bottom of the grill. Check the gap of the new part before installing. Loosening and tightening the two jam nuts will move the electrode tip, set at 1/8".

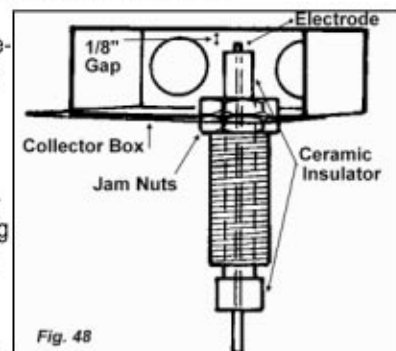

Flare-Ups

Expect and encourage a moderate amount of flare-up to enhance flavor. To control excessive flare-ups - trim excess fat before cooking, lower the heat setting, move meat to other side of grill if possible, cook with lid down.

For immediate control of flare-ups, throw a small amount of baking soda directly on the briquettes and lower heat setting. Do not douse flare-ups with water, this only worsens the flame.

Maintenance & Tube Bending

General Maintenance

Sear Magic Grid System Care

For best results, preheat the grill for 10 minutes.

1. Use a brass bristled brush to clean top rungs.
2. Use the supplied "Forked Grid Tool" to clean the valley areas between the main rungs. Simply run the tool back and forth with enough pressure to remove the debris. For heavy build-ups you can use a plastic scouring pads. **Do not use abrasives like steel wool pads or caustic cleaners such as oven cleaners. They will damage the grid surface and void your warranty.**
3. If a grid gets a slight bow, lay it on a flat surface and apply pressure to the ached area. This will flatten the grid to its original configuration.

Note: Over time the grids may change color slightly. This is normal and will not effect the grids performance or durability.

Stainless Steel Cleaning (TJK, Optimum Console)

Before Cleaning, determine which way the "grain" of the metal runs and always clean with the grain. NEVER USE STEEL WOOL PADS TO CLEAN STAINLESS STEEL.

1. Routine cleaning is done with a warm soapy water applied with a sponge or soft cloth. Always rinse with clean hot water and wipe dry with a soft cloth. Glass cleaners like Windex also works well.
2. Stubborn stains can be removed with a mild non-scratching abrasive household powder. Add a small amount of vinegar to the scouring powder to increase its potency.
3. Commercial stainless steel cleaners and polishers also work well, such as MHP's Stainless Steel Cleaner (Part #SSC).

Note: Over time the stainless steel will turn a mild gold patina from the grill's heat. This is normal.

FLEXIBLE STAINLESS STEEL GAS TUBE BENDING

For 2' & 4" Posts With Access Doors.

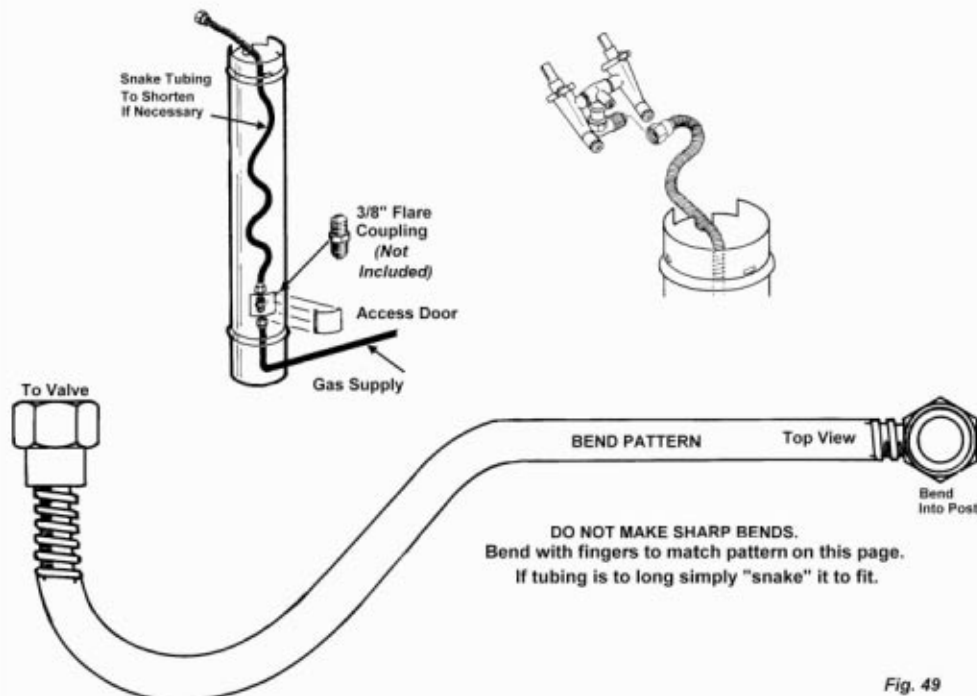

Troubleshooting

Problem	Cause	Check
Yellow or orange flame and the smell of gas.	<ol style="list-style-type: none"> 1. Blockage in the venturi tube or orifice. 2. Orifice not seated properly in the venturi Tube. 3. Bent or kinked hose. 	<ol style="list-style-type: none"> 1. Clean venturi (See section "Annual Maintenance"). 2. Orifice must fit into venturi tube at least 1/4" to 1/2" 3. Check gas supply line. Also, check all connections.
Burner does not light or flame is low in HIGH position.	<ol style="list-style-type: none"> 1. Could be a kink in the gas supply line. 2. LP tank could be low or empty. 3. LP regulator excess flow feature has been activated. 	<ol style="list-style-type: none"> 1. Straighten 2. Refill LP cylinder 3. Turn grill control knobs off, close LP tank valve and reopen valve slowly. Wait 5-seconds before turning on grill valves
Erratic flame pattern from burner or flame is low when burner control knob set at HIGH or flames do not run the whole length of burner.	Dirty burner	Clean burner holes with a small pin. Be careful not to enlarge holes
Constant flare-ups	<ol style="list-style-type: none"> 1. Grill too cold before start of cooking. 2. Cooking grate or briquettes may be heavily coated with burned-on grease. 3. Fatty foods. 4. Heat setting too high. 5. Briquettes laid out improperly allowing grease to hit flame. 	<ol style="list-style-type: none"> 1. You should always pre-heat grill for 5 to 10 minutes before cooking. 2. Clean cooking grate. Clean and turn over briquettes. 3. Trim excessive fat from fatty meats. 4. Lower heat setting. 5. Layout briquettes according to instructions on page 18.
Briquettes have turned black.	Dripping grease has Burned-onto briquettes.	Turn briquettes over. Over time black side of briquettes will self clean.
Food sticks to cooking grid.	<ol style="list-style-type: none"> 1. Cooking grid is probably too hot. 2. Food being turned before sear lines are produced. 	<ol style="list-style-type: none"> 1. Lower heat setting. Grids, especially Sear-Magic transfer heat quickly. You'll need to experiment with heat setting to get the best results. Or use a non-stick cooking spray. 2. Time food to turn over only once.
Flame blows out	During periods of high wind and sometimes while cooking on a low setting, flame may be extinguished.	<ol style="list-style-type: none"> 1. On cart, simply turn away from wind. 2. Increase the heat setting.
Oxidation Graying of grill head.	Due to extreme cooking temperatures and severe weather conditions the grill body may bleed through the paint and cause white spotting (Oxidation).	Use a wire brush, sandpaper and wash with mild soap to remove flaking paint and grease. Repaint with high quality heat resistant paint similar to MHP's BF-1 Paint.
Grill does not get hot.	<ol style="list-style-type: none"> 1. See low flame above. 2. On natural gas, inadequate pressure at grill. 3. Incorrect orifice. 	<ol style="list-style-type: none"> 1. See low flame above. 2. Check pressure. Should be at or near 7" water column. 3. Check orifice size.

CAUTION: If problems can not be corrected using these methods, contact your local MHP dealer for assistance.

Parts Information

Parts are divided below into lists associated with the three different grill configurations. When ordering a part please provide the grill identification, part number, quantity and product description. To order contact your local MHP dealer or MHP's customer service: phone: 1-888-647-4745, fax: 1-800-637-2918, or E-mail: customerservice@mhpgrills.com for the dealer nearest you.

Item	Qty.	WNK3 Part #	JNR 3Part #	TJK Part #	Description
1	1	GG-TC3	HH-TC2	**	Top Casting
2	1	GG-TG4	GG-TG4	GG-TG4	Thermometer
3	1	GG-SH	HH-SH	**	Sta-Kool Handle
4	2	GG-SHC	HH-SHC	**	Sta-Kool Handle End Caps
5	3	GG-M8	GG-M8	GG-M8	1/4-20 x 3/4" Hex Head Bolt
6	2	GG-M30	GG-M30	**	1/4 x 20 x 1 1/2" Hex Head Bolt
7	2	GGM-4	GGM-4	(10)GG-M13	10-24 Kep Nut
8	1	GG-TS	HH-SSTS	GG-TS	All Purpose Rack
9	1	GG-BC2	HH-BC	GG-TBC	Bottom Casting
10	1	GG-DLB13TL	HH-DSB13	GG-DLB13TL	Burner with Venturi
11	2	GG-M15	GG-M15	GG-M15	8-32 x 1 1/2" Rd. Hd. Sltd. Screw
12	1	GG-IB	GG-IB	GG-IB	Collector Box & Electrode
13	1	GG-M17	GG-M17	GG-M17	Flat Washer for Ignitor
14	1	GG-JN	GG-JN	GG-JN	1/8-27 Jam Nut
15	1	GG-Grate-P	HH-Grate-P	GG-Grate-P	Bottom Grate
16	2	GG-SS-Grid	(1)HH-SS-Grid	GG-SS-Grid	Cooking Grids
17	1	GG-BQ3	HH-BQ3	GG-BQ3	Bag of Briquettes (67 pcs. & 53 pcs.)
18	1	GG-GCH	GG-GCH	GG-GCH	Grease Cup Holder
19	1	GG-CP	HH-CP	GG-CP	Control Panel
20	1	GG-VLV32	**	GG-VLV32	Valve #50 Orifice-Nat. Gas
1	**		HH-VLV32	**	Valve #52 Orifice-Nat. Gas
21	1	GG-VLV28	**	GG-VLV28	Valve #55 Orifice-L.P.
1	**		HH-VLV28	**	Valve #57 Orifice-L.P.
23	1	GG-ERIW	GG-ERIW	GG-ERIW	Connecting Wire for Ignitor
24	2	GG-K10	GG-K10	GG-K10	Valve Control Knobs
25	1	GG-EIB	GG-EIB	GG-EIB	Ignitor Electronic Button
26	1	GG-M16	GG-M16	GG-M16	1/4-20 x 1/2" Hex Head Bolt
27	13	GG-M4	(11)GG-M4	(8)GG-M4	1/4-20 Kep Nut
28	2	GG-SSB	(1)GG-SSB	GG-SSB	Upper Shelf Bracket
29	4	GG-M5	(2)GG-M5	GG-M5	1/4-20 x 1 1/2" Rd.Hd.Sltd.Screw
30	4	GG-M4	(2)GG-M4	GG-M4	1/4-20 Kep Nut
31	2	GG-SSII	(1)GG-SSII	HHDDSK	Side Shelf
32	4	GGM62	(2)GGM62	**	1/4 x 20 x 1 1/4" Phillips Head Bolt
33	4	SW1	(2)SW1	**	1/4 x 20 Lock Washer
34	2	GG-M31	GG-M31	**	Graphite Gasket
36	4	GG-M26	(2)GG-M26	(8)GG-M26	10-24 x 1 1/4" Rd. Hd. Screw
66	1	GS-801	GS-801	GS-801	Gaslow Regulator, L.P. Hose Assy.
68	1	GG-M25	GG-M25	GG-M25	Label (L.P., Nat.) A.G.A.
70	2	GG-LPP	GG-LPP	GG-LPP	Lid Pivot Pin
71	4	GG-LPP-1	GG-LPP-1	GG-LPP-1	Hitch Pin for Lid & Burner
76	1	BR-VTC	BR-VTC	BR-VTC	Venturi Tube Cleaning Brush
77	2	BR-SG	BR-SG	BR-SG	Spider Guards
81	1	GG-DEF	HH-DEF	GG-DEF	Heat Shield
83	2	GG-CPB	GG-CPB	GG-CPB	Control Panel Brackets
84	2	GG-M61	GG-M61	GG-M61	1/4 - 20 x 1/2" Phillips Head Bolt
85	2	GG-M62	GG-M62	GG-M62	1/4 - 20 x 1 1/4" Phillips Head Bolt

TJK Lid and Upper Side Shelves Parts Not listed above (See Inset Illustrations)

T1	2	GG-TEC		GG-TEC	Aluminum End Cap
T2	1	GG-TLG		GG-TLG	Logo
T3	1	GG-TSH		GG-TSH	Stainless Steel Handle
T4	12	GG-M60		GG-M60	1/4 x 10 x 3/4" Phillips Truss Screw
T7	10	GG-M13		GG-M13	10 x 24 Kep Nut
T32	1	GG-TSI		GG-TSI	Stainless Steel Lid
Fig 51	1			TJKLID	TJK Lid Complete

PARTS NOT SHOWN OR LISTED FOR WRG and TRG INFRA-RED GRILLS:

PART #	DESCRIPTION
GGIRB (3)	Infrared Burners
GGOH (3)	Orifice Holder
GGBC3IR (1)	WRG Bottom Casting
GGTRCIR (1)	TRG Bottom Casting
GGCPI (1)	Infrared Control Panel
GGCPLBLIE (1)	Control Panel Label
GGIAC (1)	Access Door Cover
GGIBC (3)	Burner Clips
GGICPB (2)	Infrared Control Panel Brackets
GGIEB3 (1)	3 Prong Electric Module
GGIE3S (1)	Electronic Ignitor Box Cover
GGIGC (1)	Grease Cover
GGIIP (3)	Infrared Ignitor Probe
GGIPS (3)	Infrared Ignitor Probe Shield
GGMAN-P (1)	LP Manifold & Valve
GGMAN-N (1)	Natural Manifold & Valve
GGMH (1)	Match Holder
GGMHC (1)	Match Holder Chain
GGW1-06 (1)	20" Ignitor Wire
GGW2-06 (1)	14" Ignitor Wire
GGW2-06 (1)	9" Ignitor Wire

PARTS NOT SHOWN OR LISTED FOR WHRG and THRG HYBRID GRILLS:

PART #	DESCRIPTION
GGIRB (1)	Infrared Burner
GGHCSSB (2)	Cast Stainless Steel Burners
GGOH (3)	Orifice Holder
GGBQ3R (46)	Porcelain Briquettes
GGBC3IR (1)	WHRG Bottom Casting
GGTBCIR (1)	THRG Bottom Casting
GGCPI (1)	Control Panel
GGCPLBLHE (1)	Control Panel Label
KKK10 (3)	Valve Knobs
GGIEB3 (1)	3 Prong Electric Module
GGIEB3S (1)	Electronic Ignitor Box Cover
GGGRATEH (1)	Briquette Grate
GGHBC (2)	Oval Stainless Burner Clips
GGHIB (2)	Gas Collector Box
GGIAC (1)	Access Door Cover
GGIBC (1)	Infrared Burner Clip
GGICPB (2)	Control Panel Bracket
GGIGC (1)	Ignitor Grease Cover
GGIIP (1)	Infrared Ignitor Probe
GGIPS (1)	Infrared Probe Shield
GGMAN-P (1)	LP Manifold & Valve
GGMAN-N (1)	Natural Manifold & Valve
GGMH (1)	Match Holder
GGMHC (1)	Match Holder Chain
GGW1-06 (1)	20" Ignitor Wire
GGW2-06 (1)	14" Ignitor Wire
GGW2-06 (1)	9" Ignitor Wire

Parts Information

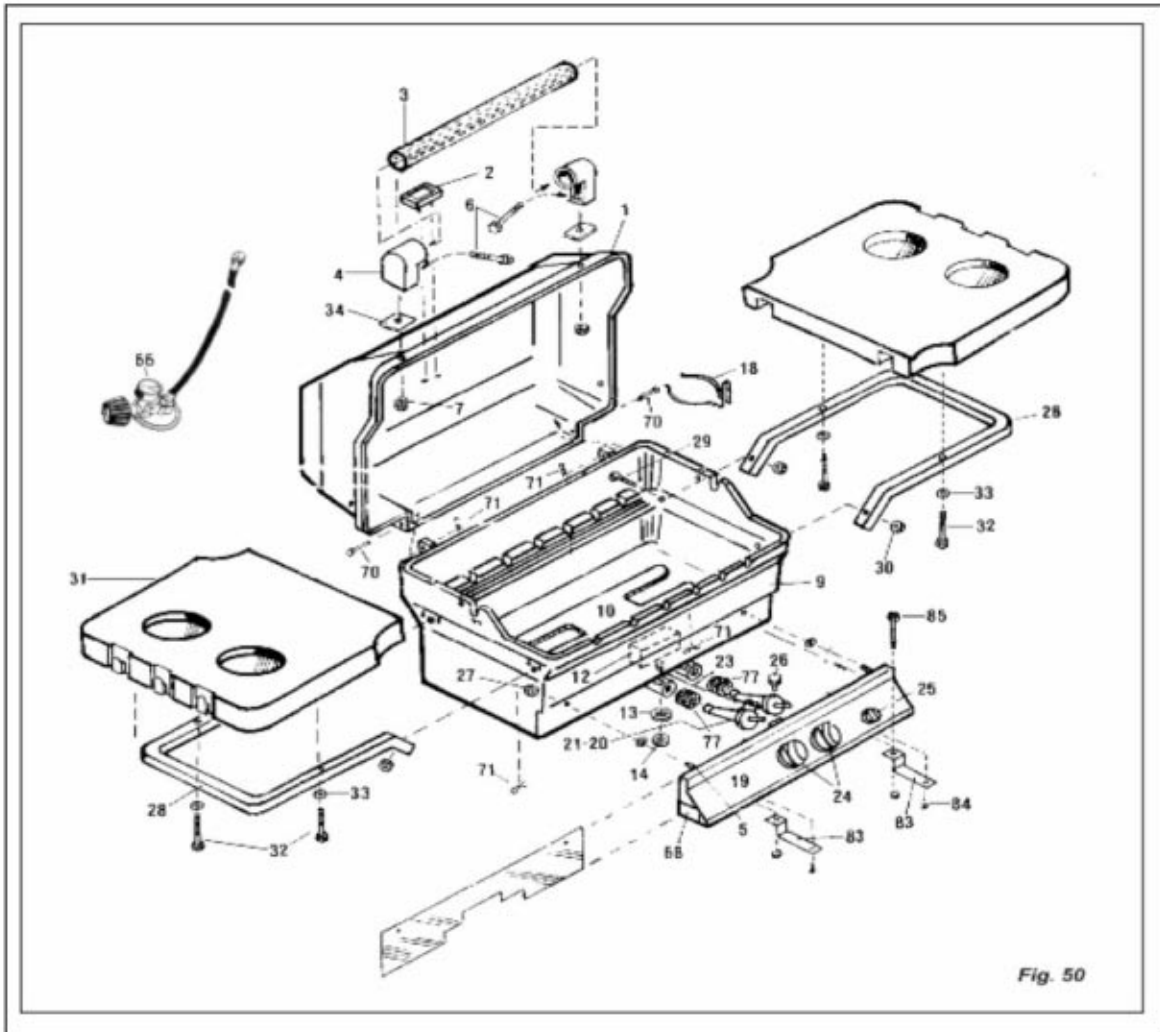

TJK LID AND UPPER SIDE SHELF PARTS IDENTIFICATION

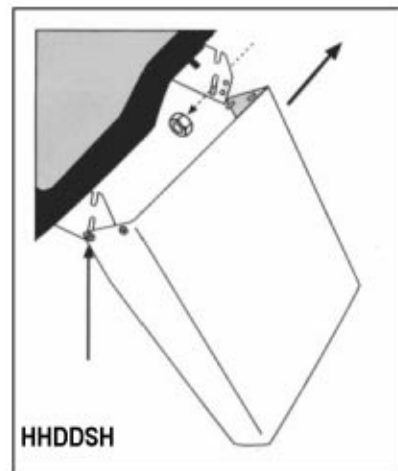
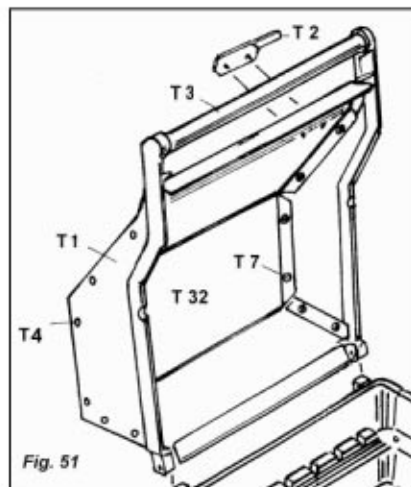

Parts Information

JCP3, JCN3, WCP3 & WCN3 DURO CAST CART (Nat. and LP Gas) JCP3 and JCN3 (Fits JNR4 Grill Heads)

WCP3 and WCN3 (Fits WNK4, WRG4, WHRG4, TJK2, TRG2 and THRG2 Grill Heads)

Item	Qty.	Part #	Part #	Description
50	1	GG-LSR3	HH-LSR3	Lower Frame Shelf
52	2	GG-LL2	GG-LL2	Long Leg
53	1	GG-SL2B	GG-SL2B	Short Back Leg
53A	1	GGSL2F	GGSL2F	Short Front Leg
54	2	GG-AWP	GG-AWP	Axle Hitch Pins
55	11	GG-M5	GG-M5	1/4-20 x 1 1/2" Rd. Hd. Sltd. Screw
39	15	GG-M4	GG-M4	1/4-20 Kep Nut
56	2	GG-WL	GG-WL	8" Rubber Wheel
57	1	GG-M23	GG-M23	Axle Washer
58	2	GG-HC	GG-HC	Plastic Hub Cap
59	1	GG-Ring	GG-Ring	LP Tank Holder Ring
60	1	GG-M9	GG-M9	1/4-20 Thumb Screw
47	1	GG-M8	GG-M8	3/4" S.S. Hex Bolts
62	1	AW-ASCPL2	AW-ASCPL2	12' Hose (Nat. Gas)
63	1	AWSCPL3	AWSCPL3	Brass Quick-Disconnect (Nat Gas)
64	1	GG-HRC	GG-HRC	Hose Retaining Ring
65	1	GG-M24	GG-M24	1/4 - 20 x 1/2" Rd. Hd. Sltd. Screw
7	1	GG-M13	GG-M13	10-24 Hex Kep Nut
67	1	AW-ASCPL5	AW-ASCPL5	Quick-Disconnect Dust Plug (Nat. Gas)
69	2	AW-ASCPL4	AW-ASCPL4	DustCap (Nat. Gas)
74	1	**	HH-M28	1/4 - 20 x 3/4" Rd. Hd. Sltd. Screw
82	1	GG-GC	GG-GC	Grease Cup
83	1	GGAXLP	GGAXLP	Axle

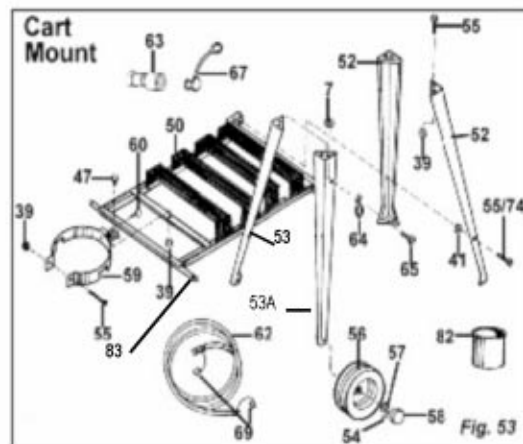

MPB Deck/Patio Mount (Nat. & LP) (Fits All Grill Heads)

Item	Qty.	Part #	Description
41	1	GG-CT-SS	28" SS Tubing
46	1	GG-P2	2' Post
45	1	GG-APB	Patio Base
48	1	GG-Clip	Tube Clip
75	1	GG-ADC	Post Access Door
82	1	GG-GC	Stainless Steel Grease Cup
39	7	GG-M4	1/4-20 Kep Nut
40	7	GG-M8	1/4-20 x 1/2" Hex Head Bolt
47	4		1/4" Flat Washer
49	1	GG-M15	8-32 x 1/2" Self Taping Screw

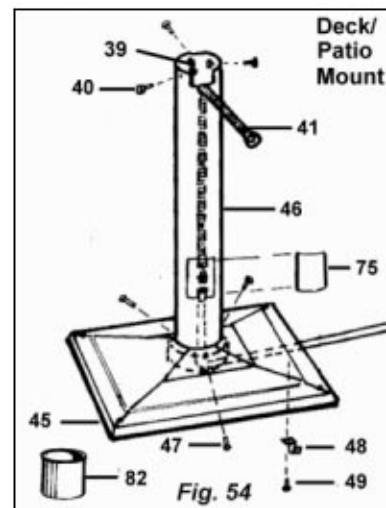

MPP Stationary Mount/In-Ground Installation (Nat. & LP) (Fits All Grill Heads)

Item	Qty.	Part #	Description
38	1	GG-P4	4' Post
75	1	GG-ADC	Post Access Door
41	1	GG-CT-SS	28" SS Tubing
82	1	GG-GC	Stainless Steel Grease Cup
39	3	GG-M4	1/4-20 Kep Nut
40	3	GG-M8	1/4-20 x 1/2" Hex Head Bolt

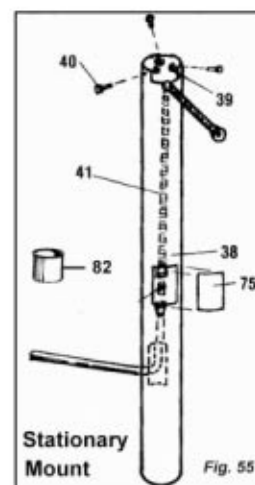

Parts Information

Stainless Steel and Aluminum Column Mount (Nat. & LP)

Item	Qty.	Description
84	1	Stainless Steel Front Panel
85	1	Cast Aluminum Base
86	1	Stainless Steel or Aluminum Column
87	1	Heat Shield
82	1	Stainless Grease Cup
87	4	1/4" -20x1 1/4" S.S. Hex Head Bolt
88	12	1/4" -20 S.S. Kep Nuts
89	10	1/4" -S.S. Flat Washers
90	1	6" Wheels (Cart Only)
91	1	Axle (Cart Only)
92	1	Tank Lock Bar
93	4	Rectangular Washers
94	8	1/4" -20 x 3/4" S.S. Hex Head Bolt
95	1	2-Piece Gasket (Stainless Steel Column)
41	1	28" S.S. Tubing (Nat. Gas Patio Base)
54	2	Hitch Pins
58	2	Plastic Hub Caps
62	1	12' Hose (Included With Portable Nat. Gas Carts)
63	1	Brass Quick-Disconnect (Portable Nat. Gas Carts)
67	1	Quick-Disconnect Dust Cap (Portable Nat. Gas Carts)
69	2	Dust Cap (Portable Nat. Gas Carts)
Not Shown	2	Aluminum Reinforcing Bars (Aluminum Column Only)

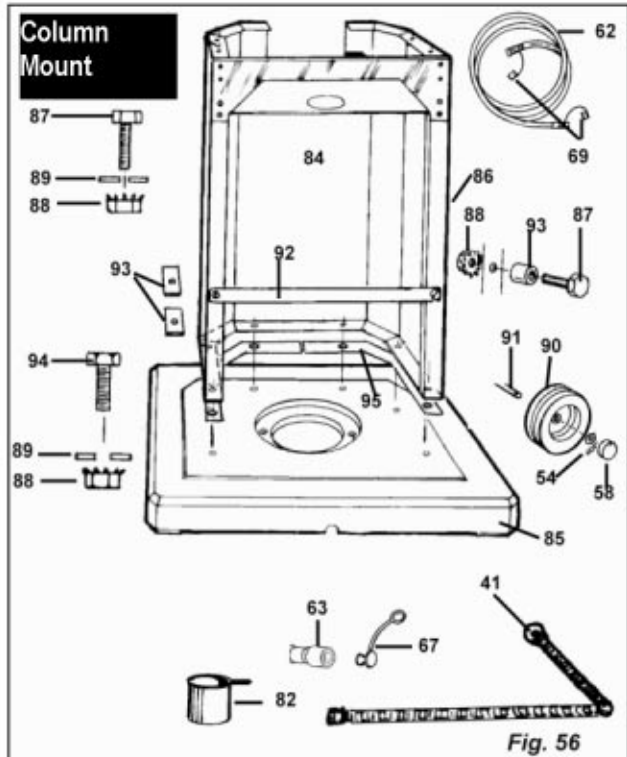

Fig. 56

NMS-GS, NMS2-GS Enclosure Sleeve and NMS-DS Door Set NMS-GS (Fits WNK4 and TJK2) NMS2-GS (Fits WRG4, WHRG4, TRG2 and THRG2)

GRILL HEAD ENCLOSURE SLEEVE

Item	Qty.	Description
B6	1	Front Face Plate
B7	1	Right Side "L" Bracket
B8	1	Left Side "L" Bracket
B9	1	Rear Support Bracket
B10	1	Grease Tray
B12	12	1/4"-20 x 3/4" Hex Head Bolt
B13	4	1/4" -20x1 1/4" Hex Head Bolt
B14	4	1/4" -20 Nut
B15	4	1/4" -20 Flat Washer
B16	16	1/4" -20 Lock Washer
B17	1	Heat Shield

DOOR SET

B1	1	Left Hand Door
B2	1	Right Hand Door
B3	1	Door Set Frame
B4	1	Door Handles
B5	1	Magnetic Catches

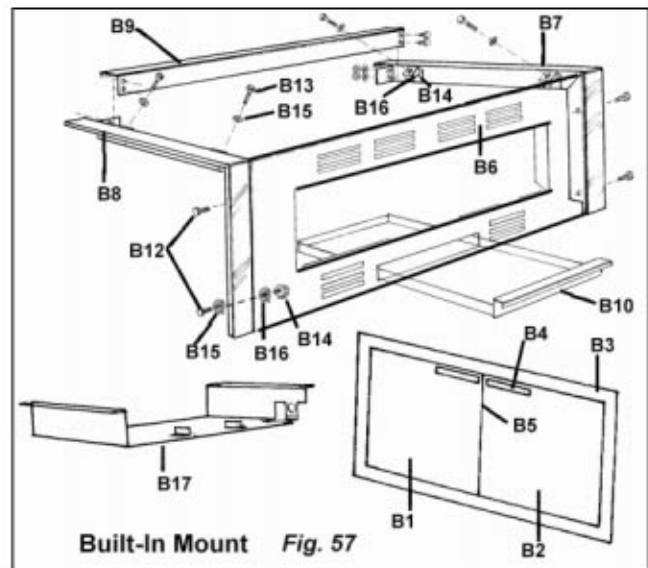

Built-In Mount Fig. 57

SearMagic Warming Rack & Cooking Grids

Item	Qty.	Part #	Description
78	3	GG-Grid-S	SearMagic Grids (WNK & TJK)
79	2	HH-Grid-S	SearMagic Grids (JNR)
80	1	GG-TS-S	All Purpose Warming Rack

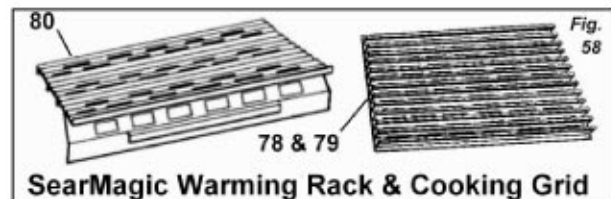

SearMagic Warming Rack & Cooking Grid

COOKING TECHNIQUES

More Versatile than your kitchen oven...your MHP Gas Grill roasts, sears, broils, spit-roast, bakes, steams and smokes. The eating enjoyment of each cooking technique will result in a distinctive flavor for entertaining friends or a welcomed treat for a family meal.



Direct—For grilling/searing steaks, chops, burgers, frankfurters, sausages, fish fillets, chicken parts or shish-ka-bobs. Your MHP Gas Grill is designed to cook with the lid closed, except for quick searing or more of a char flavor. Close lid to finish grilling, retaining natural juices, moisture and preventing flare-ups.

Indirect (use one side of burner) - For roasts, ribs, ham, whole chicken, turkey, game or whole fish. Using the indirect heat method, turn on one side of burner, then place food on the cooking grid over the side of burner that's not lit.



Indirect (use of water pan) - An aluminum foil pan is centered on the briquettes to moderate the temperature and to add moisture and flavor. Fill the pan with water or other ingredients, (add to water; wine, apple juice, orange juice, herbs, spices, etc). The cooking juices from the food drops into the water pan creating a savory water vapor from which the foods absorb flavor and moisture.

Pan Roasting—For large cuts of meat, pot roast, turkey, whole chickens, duckling, aluminum foil drip pan or shallow metal baking/roasting pan on top of cooking grid. For extra flavor, add your favorite vegetables or some wine or fruit juice or garlic, onions to the drip pan. Use liquid to baste or gravy.



Smoke (addition of wood chips or chunks) - Ordinary meat, whole fish, poultry and game becomes a taste sensation when smoked. Using the water pan technique and your favorite wood soaked in water for several hours or overnight. Place chips in the convenient MHP reusable smoke box or wrap in aluminum foil, poke a couple of small holes in the foil pack. Place holes side up directly on briquettes along side of water pan.

Rotisserie—Poultry, lamb, beef and pork tastes more of themselves when spit-roasted. Meat is rotated over the heat keeping it constantly bathed in its own juices, insuring that all sides become done at one time. A drip pan can be used to collect the drippings for basting or gravy..



GETTING TO KNOW YOUR MHP GAS GRILL

Some Questions and Answers.

There is really no mystery to gas grill cooking.

The best of two worlds are combined in the use of a gas grill, the flavor of charcoal cooking and the convenience and heat control of your kitchen oven.

Let's look at some of the most commonly asked questions about gas grill cooking:

Can I Get That Charcoal Flavor?

The fact is that charcoal does not flavor your outdoor meal, but is only a heat source. The MHP Gas Grill utilizes a special porcelain briquette above the patented burner that heats up fast and spreads the heat evenly. The delightful backyard taste that comes with barbecue cooking is caused by meat drippings falling on the heat source where they are vaporized to rise and add outdoor flavor to the food.

What control Settings Should I Use?

The greatest cause of gas grill cooking failures is excess heat. Understanding the three basic heat settings along with experience, you will find the precise heat you need will become easier and easier to achieve.

HIGH-Is used primarily for preheating and cleaning. It may also be used for quick searing of meats, such as steaks and chops.

MEDIUM-For broiling or quick cooking foods. Also use MEDIUM for searing foods that have been cooked at LOW, for more of a smoke flavor.

LOW-Most foods should be cooked at LOW. Even thick steaks, which have been seared on both sides at HIGH, will finish with better texture and more juices at LOW. All roasts, poultry, rotisserie and smoke cooking should be at LOW.

Do I Cook With The Lid Open Or Closed?

Like your kitchen oven, the MHP Gas Grill is designed to cook with the lid closed, except for quick searing. Cooking with the lid closed helps food retain natural juices, moisture, enhances flavor and keeps annoying flare-ups to a minimum. Also, heat is reflected from the lid, and meat cooks not only from below, but, evenly on all sides from circulating hot air, (similar to convection oven) for faster, more fuel efficient cooking.

Can I cook More Than One Thing At A Time?

You can prepare entire meals in the MHP Gas Grill...and you'll love it even more. Baked potatoes, corn-on-the-cob, stuffed tomatoes, peppers, squash, vegetables, garlic bread, baked apples, pies...grill them on the warming rack or alongside the meat for complete menus.

When And How Do I Use A Meat Thermometer?

Use an oven-safe meat thermometer when cooking large pieces of meat, poultry and game to determine if cooked adequately. The thermometer should be inserted into the thickest part of the meat. For accurate temperature reading, the tip of the thermometer should not touch fat layers, bone or gristle, or if using the rotisserie, the spit rod.

What Utensils Should I Use?

Always use long handle forks, spatulas or tongs, designed especially for outdoor cooking when testing or turning food in your grill. Keep hot pads or mitt handy for removing food from cooking grid. For juicier more flavorful meats, use tongs when handling and turning. Piercing the meat with a fork allows juices to escape.

Can I Use Aluminum Foil?

Aluminum foil is probably the most convenient accessory of all. Foil can be used to cook food on or in. It also serves as a drip pan and heat deflector. Vegetables cook best when wrapped in foil. Foil holds in natural liquids, and foods cook moist and tender. Delicate foods such as fish fillets and seafood may be cooked on foil placed directly on the cooking grid. When spit-cooking foods of uneven shape, smaller parts that may cook too fast, may be wrapped in foil. Foil is also great to use in cleaning the grill. For stubborn grease or sauce build-up that is not removed during your normal cleaning process. Simply place a sheet of aluminum foil covering the Flavor Master briquettes. With the lid open, turn the control to HIGH and ignite, close lid. After about 20 minutes or so the residue will be reduced to a white powder, which is easily brushed or wiped off after the grill has cooled.

When Should I Use Seasoning and Sauces?

Salt, which tends to dry out foods, is best added after cooking. Sauces and marinades add a special taste treat when grilled. Marinades are popular because they turn less expensive cuts of meat into tasty entrees. Large items such as roasts should be marinated at least 8 hours or overnight. Fish, poultry and ribs may be marinated successfully in an hour or two. Food in the marinade should be turned occasionally and kept cool under refrigeration. Sugar-based glazes and sauces will burn faster and should be brushed on during final stages of cooking or used as a table sauce.

Can I Cook Frozen Food?

For best results, thaw all meat in the refrigerator. This allows for juicier, more flavorful meats. However, very good results can be obtained by cooking your steaks while still frozen. Just remember to allow more cooking time. The microwave oven provides an alternative for thawing your meat, although it is our least recommended method. Fish and vegetables can be successfully grilled frozen.

How Economical Is A Gas Grill?

You will save on your utility bill using a gas grill instead of conventional oven or charcoal cooking. Less energy for air-conditioning, fewer dishes to wash and no charcoal or starter fluid to buy. Charcoal grilling costs 30 times more than natural gas and 10 times more than propane gas to cook an average meal.

Handling Food Safely

Always thaw your frozen products in the refrigerator. Never thaw at room temperature. Do not use the same cutting board or platter for raw meats and cooked meats. Wash hands, utensils, cutting boards and counters that contact raw food. Cook meats to the proper degree of doneness; Never serve ground meats rare or raw. Do not allow cooked meats to stand at room temperature. Always refrigerate leftovers immediately.



ACCESSORIES FOR ADDED VERSATILITY, CONVENIENCE AND OUTDOOR COOKING ENJOYMENT.



Successful chefs know the importance of the right utensils and equipment. Some items like hot pads/mitts, long handled spatulas, forks and tongs are essential. When you're cooking with a gas grill, specialized accessories make barbecuing easier, more convenient and enjoyable for everyone, from the cook or chef to the onlooker. The photo is a representation of accessories available to go with your MHP Gas Grill. For availability of complete accessory line, visit your local MHP Retailer.

OUR POPULAR 5-PIECE STAINLESS STEEL SPORTS-THEMED BBQ TOOL SETS



GOLF



FOOTBALL



TENNIS



BASEBALL

Outdoor Creations From MHP™



Modern Home Products Corporation
150 South Ram Road, Antioch, Illinois 60002
Phone: 1-888-647-4745 • 847-395-6556
Fax: 1-800-637-2918 • 847-395-9121
E-Mail: customerservice@mhpgrills.com
Web Site: www.mhpgrills.com



MHP Grills are covered by U.S. Patent Nos. D 326,207 and D 359,877; Burners by U.S. Patent Nos. 4,267,506; 4,373,505; 4,267,816; 4,488,534
MHP configuration, Chef's Choice, BBQer's Choice, SearMagic, Flavor Master, DuroCart and Infra-Roast are trademarks of Modern Home Products Corporation.

©2006 Modern Home Products Corporation.

(9/06)

Printed In U.S.A.