



DESIGN

The Mill House, Packington Hayes,
Nr. Lichfield, Staffordshire WS14 9PN. UK
Tel: 01543 434 580 Fax: 01543 434 581
E-mail: sales@spa-uk.co.uk
Web Site: www.spa-uk.co.uk

Thank you for purchasing an SPA SFI 17.1 system

Thank you for purchasing a SPA SFI 17.1 system. It is important that you read the following instructions carefully before attempting to install your fire suppression system.

The performance of this system could be affected if it is in anyway modified or tampered with may make void its homologation. Please ensure that should any parts need to be replaced; only genuine SPA components are used.

Should you require any assistance, please do not hesitate in contacting SPA Design on 01543 434 580 or SPA Technique on 317-271-7941.

IMPORTANT NOTE

The purpose of this along with any other vehicle fire suppression system is to provide sufficient time in which to control the fire to enable the occupants to leave the vehicle. In ideal conditions, the fire will be extinguished completely but this can not be guaranteed. The main purpose is to curb the intensity of either an engine or cockpit fire to provide the means for the occupants to leave the vehicle or for outside assistance to be given.

Table of Contents

| | |
|-----------------|---|
| Page 3-4 | System contents for Extreme (3M™ Novec™ 1230) |
| Page 5 | System contents for FireSense powered by FireAde® (FireAde2000 Climate Control -40C) |
| Page 6 | Fitting instructions |
| Page 7 | Suggested nozzle location |
| Page 8 | Nozzle orientation, maintenance & notes |
| Page 9 | Extreme data sheet |
| Page 10 | Pull cable installation for lever valve & machined head |
| Page 11 | Pull cable installation for LW (light weight) head |
| Page 12 | Pull cable installation for 3 way activation head |
| Page 13 | Wiring of electrical activation for the 3 way activation head |
| Page 14 | Electrical details |
| Page 15 | Attachment of pull cable for automatic system |
| Page 16 | Configuration of automatic system without pull cable or for transportation |

CONTENTS

SPAex SYSTEM CONTENTS LIST

Extreme with 3M™ Novec™ 1230

SPAex SFI 5 (lever valve) & **SPAex SFI 5M** (machined head 2 pull cable) & **SPAex SFI 5LW** (machined head single pull cable - lightweight)

| | |
|--------------------|---------------------------------------|
| 2 x 02-SPAT 099 | retaining straps (for SFI 5 & SFI 5M) |
| 1 x 02-SP 018 | 6 foot pull cable |
| 2 x 02-SP 098 | nozzles |
| 1 x 02-SPAsfi 011 | T fitting |
| 1 x 02-SPAsfi 012 | bulkhead fitting |
| 10 x 02-SPAsfi 020 | 5/16 inch aluminum tubing per foot |
| 1 x 02-SP 017 | E sticker (4") |

SPAex SFI 10 (lever valve) & **SPAex SFI 10M** (machined head 2 pull cable) & **SPAex SFI 10LW** (machined head single pull cable - lightweight)

| | |
|--------------------|---|
| 2 x 02-SPAT 112 | retaining straps |
| 1 x 02-SP 018 | 6 foot pull cable |
| 4 x 02-SP 098 | nozzles |
| 3 x 02-SPAsfi 011 | T fitting |
| 1 x 02-SPAsfi 012 | bulkhead fitting |
| 10 x 02-SPAsfi 020 | 5/16 inch aluminum tubing per foot foot |
| 1 x 02-SP 017 | E sticker (4") |

SPAex SFI 10 A (NASCAR trunk/fuel cell system, nozzle is patented)

| | |
|-----------------|------------------|
| 2 x 02-SPAT 112 | retaining straps |
|-----------------|------------------|

SPAex SFI 5 3W (3-way activation head) & **SPAex SFI 5 LW-3W** (3-way activation head - lightweight)

| | |
|--------------------|------------------------------------|
| 2 x 02-SPAT 099 | retaining straps (for SFI 5 3W) |
| 1 x 02-SP 018 | 6 foot pull cable |
| 2 x 02-SP 098 | nozzles |
| 1 x 02-SPAsfi 011 | T fitting |
| 1 x 02-SPAsfi 012 | bulkhead fitting |
| 10 x 02-SPAsfi 020 | 5/16 inch aluminum tubing per foot |
| 2 x 02-SP 005 H | hirschmann plug and lead |
| 1 x 02-SP 007 H | hirschmann plug power pack |
| 1 x 02-SP 011 | internal activation button |
| 1 x 02-SP 012 | external activation button |
| 1 x 02-SP 017 | E sticker (4") |

SPAex SFI 10 3W (3-way activation head) **SPAex SFI 10 LW-3W** (3-way activation head - lightweight)

| | |
|---------------------------|------------------------------------|
| 2 x 02-SPAT 112 | retaining straps |
| 1 x 02-SP 018 | 6 foot pull cable |
| 4 x 02-SP 098 | nozzles |
| 3 x 02-SPAsfi 011 | T fitting |
| 1 x 02-SPAsfi 012 | bulkhead fitting |
| 10 x 02-SPAsfi 020 | 5/16 inch aluminum tubing per foot |
| 2 x 02-SP 005 H | hirschmann plug and lead |
| 1 x 02-SP 007 H | hirschmann plug power pack |
| 1 x 02-SP 011 | internal activation button |
| 1 x 02-SP 012 | external activation button |
| 1 x 02-SP 017 | E sticker (4") |

Optional parts

| | |
|----------------------|---|
| 02-SPAsfi 013 | 90 degree elbow, 5/16 tube to 5/16 tube |
| 02-SPAsfi 015 | Swivel 90 degree elbow 1/4bsp to 5/16 tube (can be used on lever valve, 3way activation heads and nozzles) |
| 02-SPAsfi 016 | Swivel T fitting 1/4bsp to 5/16 tube, 5/16 tube (can be used on lever valve, 3-way & LW activation heads) |
| 02-SPAsfi 021 | 5/16 inch steel tubing (this tubing is required by NASCAR, NHRA and some other racing series please check your rule book) |
| 02-SP 018 | 6 foot pull cable |
| 02-SP 019 | 12 foot pull cable |
| 02-SP 098 | Nozzle |
| 02-SP 129 | E sticker (1") |
| 02-SP 217 | Hirschmann plug power pack carbon fiber (almost half the weight of the standard power pack) |
| 02-SP 313 | 79C / 174F yellow thermal bulb for 3-way activation head |

| | |
|-------------------------------|---|
| Custom Auto Activation | power pack and fire sense wire and harness for automatic activation trigger in a given area. Please contact SPA Technique or dealer for more details. |
|-------------------------------|---|

CONTENTS

SPAfs SYSTEM CONTENTS LIST

FireSense powered by FireAde®

SPAfs SFI 5, SPAfs SFI 5LW (lever valve)

| | |
|---------------------------|------------------------------------|
| 2 x 02-SPAT 112 | retaining straps (SPAfs SFI5) |
| 1 x 02-SP 018 | 6 foot pull cable |
| 2 x 02-SP 333 | nozzles |
| 1 x 02-SPAsfi 011 | T fitting |
| 1 x 02-SPAsfi 012 | bulkhead fitting |
| 10 x 02-SPAsfi 020 | 5/16 inch aluminum tubing per foot |
| 1 x 02-SP 017 | E sticker (4") |

SPAfs SFI 10 (lever valve)

| | |
|---------------------------|---|
| 1 x 02-SP 018 | 6 foot pull cable |
| 4 x 02-SP 333 | nozzles |
| 3 x 02-SPAsfi 011 | T fitting |
| 1 x 02-SPAsfi 012 | bulkhead fitting |
| 10 x 02-SPAsfi 020 | 5/16 inch aluminum tubing per foot foot |
| 1 x 02-SP 017 | E sticker (4") |

Optional parts

| | |
|----------------------|---|
| 02-SPAsfi 013 | 90 degree elbow, 5/16 tube to 5/16 tube |
| 02-SPAsfi 015 | swivel 90 degree elbow 1/4bsp to 5/16 tube (can be used on lever valve, 3way activation heads and nozzles) |
| 02-SPAsfi 016 | swivel T fitting 1/4bsp to 5/16 tube, 5/16 tube (can be used on lever valve, 3-way & LW activation heads) |
| 02-SPAsfi 021 | 5/16 inch steel tubing (this tubing is required by NASCAR, NHRA and some other racing series please check your rule book) |
| 02-SP 018 | 6 foot pull cable |
| 02-SP 019 | 12 foot pull cable |
| 02-SP 129 | E sticker (1") |

FITTING INSTRUCTIONS

Unpack all parts and check components against kit list.

ON 3-way activation head DO NOT remove pin until pull cable is installed.

Decide the best position for the extinguisher – **IT IS RECOMMENDED THAT THE BOTTLE NOT BE MOUNTED WITH THE HEAD IN THE DOWNWARD POSITION IN THE VEHICLE.** With the 3 way activation head we recommend keeping the head away from high heat areas like near or over the exhaust as this might trigger the automatic activation.

The extinguisher label detailing contents, etc and also the pressure gauge should be visible.

Mount the plinth securely to the vehicle and put the bottle back into place.

TUBING

Each SPA SFI System kit is supplied with 5/16 aluminum tubing or steel tubing. The SPA SFI system has been designed and meets or exceeds SFI 17.1 specifications using this type of tube. After cutting tubing, deburr inside and outside for best flow and easier connection to fittings.

TUBE CONNECTIONS

All fittings for tube to nozzles and bottle are of the push-in type. Insert the tube into the fitting, push firmly until it clicks. Once in, you should not be able to pull it out.

To remove the tubing, push the tube into the fitting and at the same time push the collet back towards the fitting and then pull the tube from the fitting

Suggestions for Engine bay nozzle locations

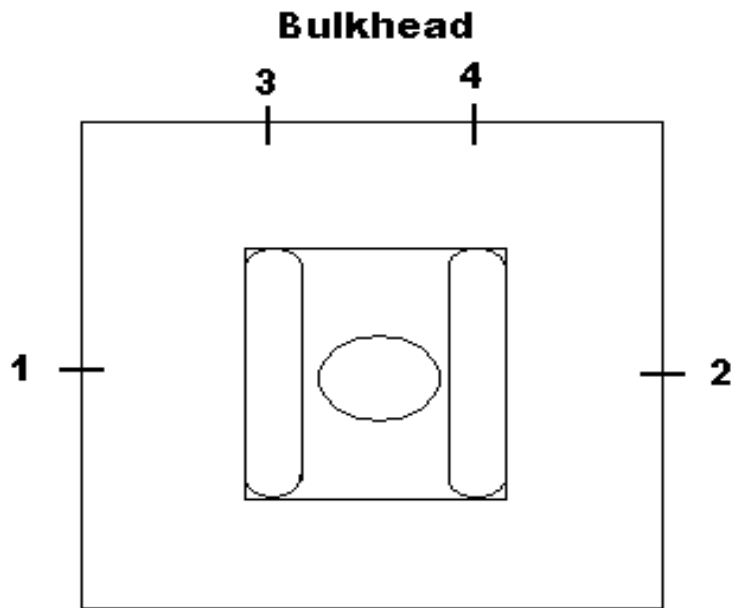

Suggestions for Cockpit nozzle locations

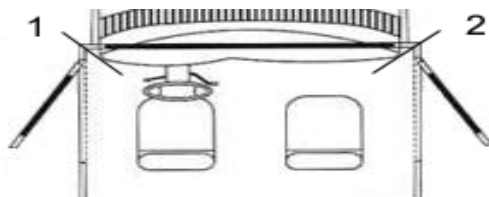

Be sure to have the nozzle spray the body of the driver. **Don't have it spray directly at helmet / face of driver as this may keep the driver from seeing to exit the vehicle.**

Correct nozzle orientation for Extreme (Novec 1230)

Make sure nozzle is mounted in this orientation to work correctly - With the holes on the body of the nozzle facing down.

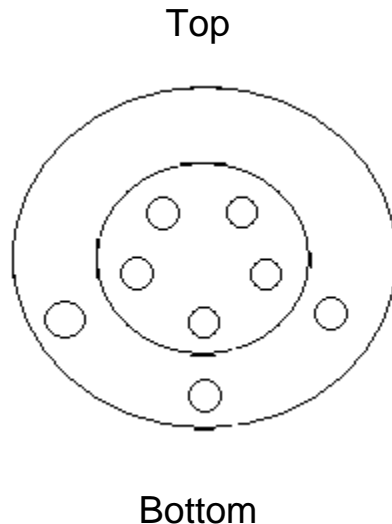

MAINTENANCE

To ensure maximum possible performance from your SPA System, the following checks and maintenance procedures should be carried out.

- Regularly check pressure gauge to ensure they are in the green sector.
- Regularly check nozzles for debris or any obstructions.
- Regularly check the integrity of the pipework and fittings.
- Regularly check the cylinder for damage.
- Your SPA Extreme system **must** be serviced every 2 years.

A service date is written on the content label on the extinguisher. It is up to you to ensure that the servicing is carried out at the correct intervals. Servicing of the system must be carried out by SPA Design or Approved Vendor

- If your system has been discharged, you must return it to SPA or dealers for servicing and refilling.

NOTES

Please ensure that you monitor the following, as you

MAY NOT pass scrutineering **IF**: -

- The needle of the gauge is in the red.
- The bottle label is worn, damaged or unreadable.
- The unit is not within the service date.
- The system is in poor condition.

EXTREME® DATA SHEET

COMPOSITION Dodecafluoro-2-methylpentan-3-one, (CF₃CF₂C(O)CF(CF₃)₂)

ODP (Ozone Depletion Potential) NONE

OPERATING TEMPERATURE - 40 - + 80 °C

FREEZING POINT - 108 °C

CRITICAL TEMPERATURE 168.7 °C

PHYSIOLOGICAL PROPERTIES No Observed Adverse Effect Level and Lowest Observed Adverse Effect Level for cardiac sensitization (halocarbons) and oxygen depletion (Inert gas).

A copy of the 3M™ Novec™ 1230 Fire Protection Fluid material safety data sheet can be obtained from SPA Design or SPA Technique upon request.

FireSense DATA SHEET

COMPOSITION Proprietary blend, information will be provided to a physician as needed

ODP (Ozone Depletion Potential) NONE

OPERATING TEMPERATURE -40 - 124°C

FREEZING POINT - 40 °C

PHYSIOLOGICAL PROPERTIES No observed adverse effect level and lowest observed adverse effect level. This product is ph neutral and contains no toxic components

A copy of the FireAde®2000 Climate Controlled Pre-Mix material safety data sheet can be obtained from SPA Design or SPA Technique upon request.

Pull cable installation for lever valve

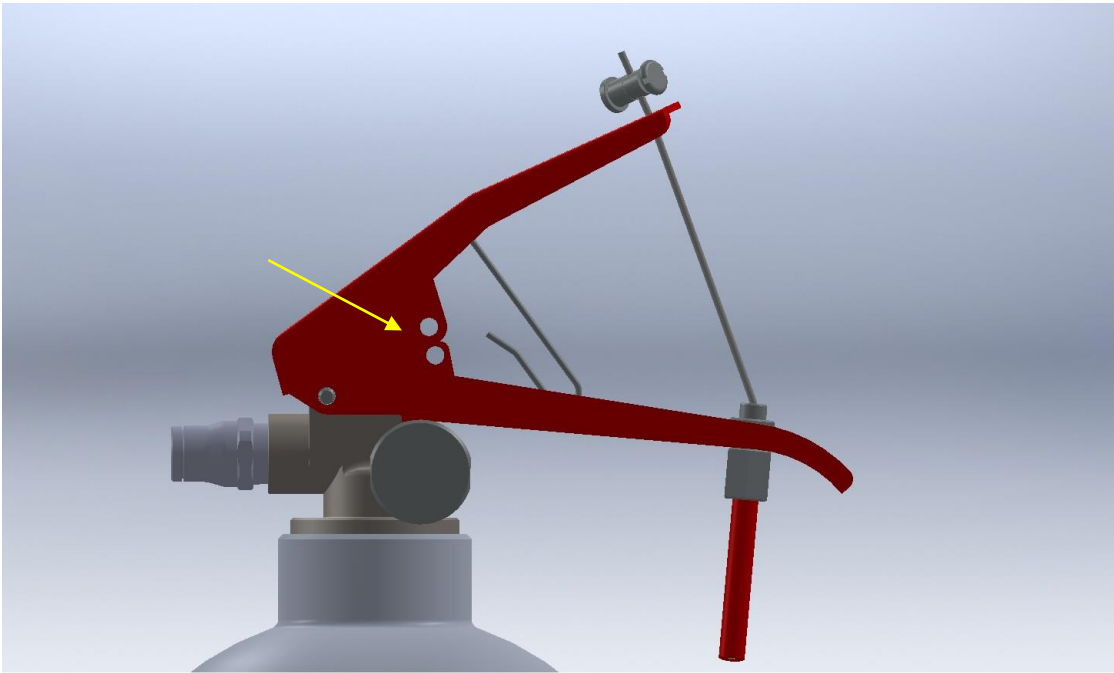

Note: Hole position shown is correct for safety pin installation(denoted by arrow). Do not try to lineup the holes for the pin as this might cause discharge.

Pull cable installation for machined head

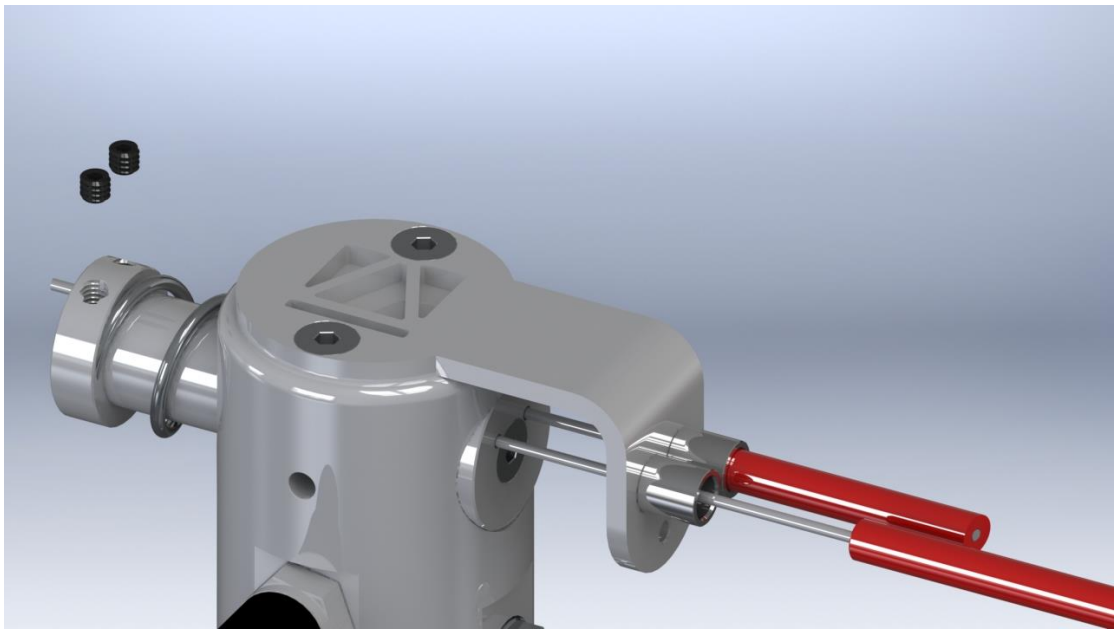

Make sure set screws (black toward upper left of image) are tight. It is recommended to use a small tread locktight to make sure these do not come loose. **System will not work if these set screws are not tightened down.** Recommended torque on the set screws is 25 inch/lbs.

Pull cable installation for LW (lightweight) head

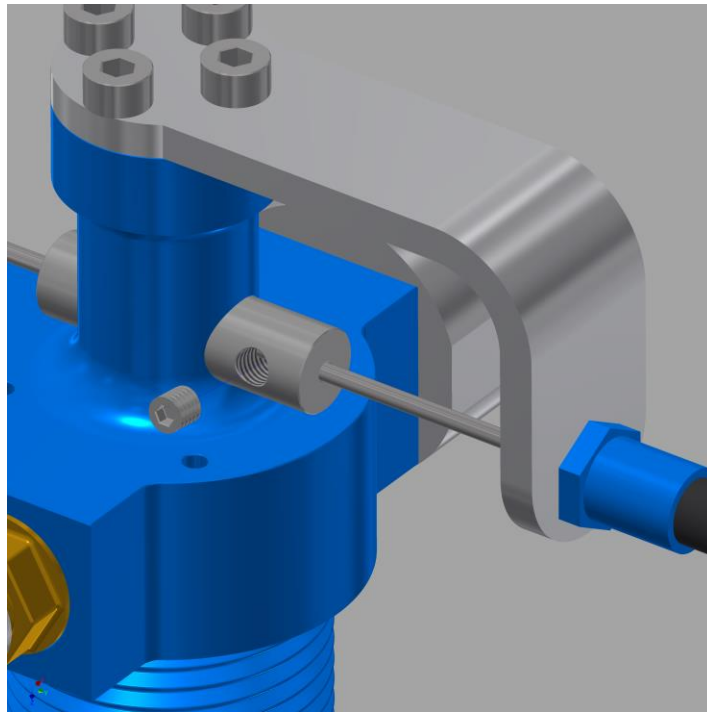

Make sure set screw is tight. **System will not work if these set screws are not tightened down.**

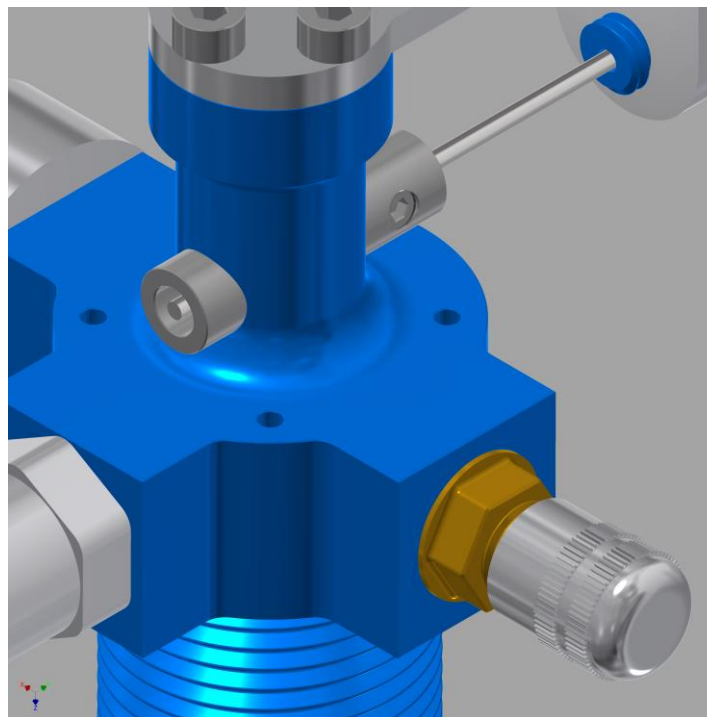

Pull cable installation for 3-way head

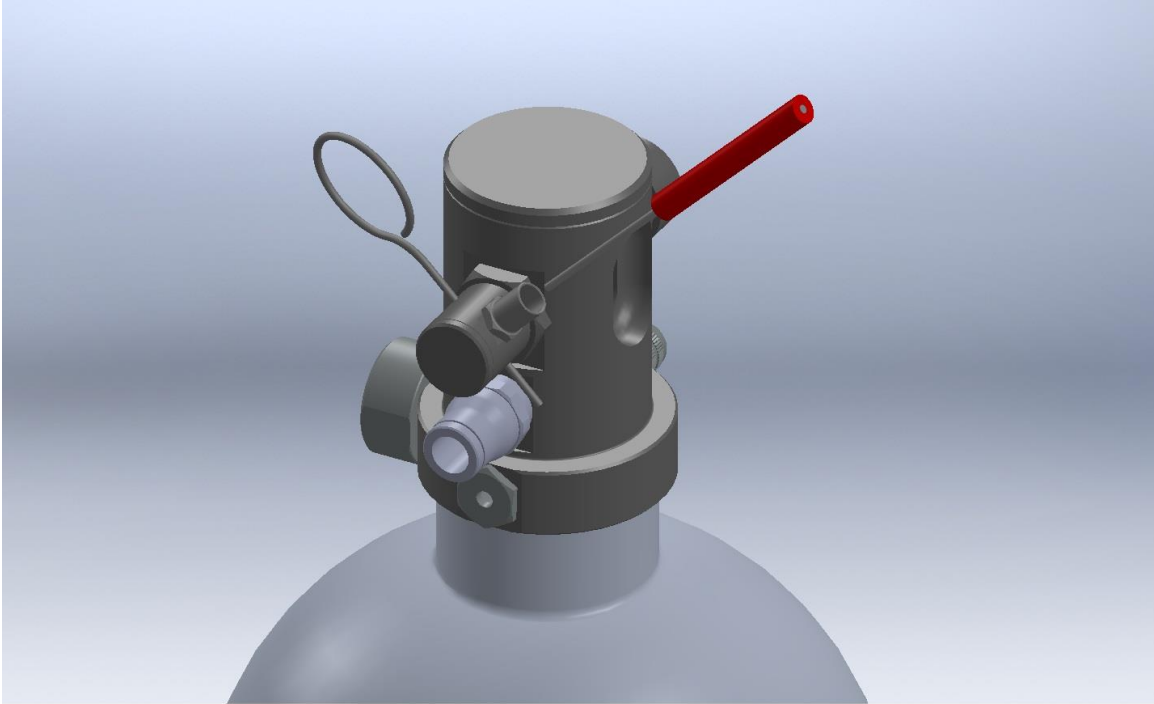

NOTE: Do **NOT** remove *pin* (denoted by arrow) before pull cable is securely installed. If pull cable is not used leave pin in place.

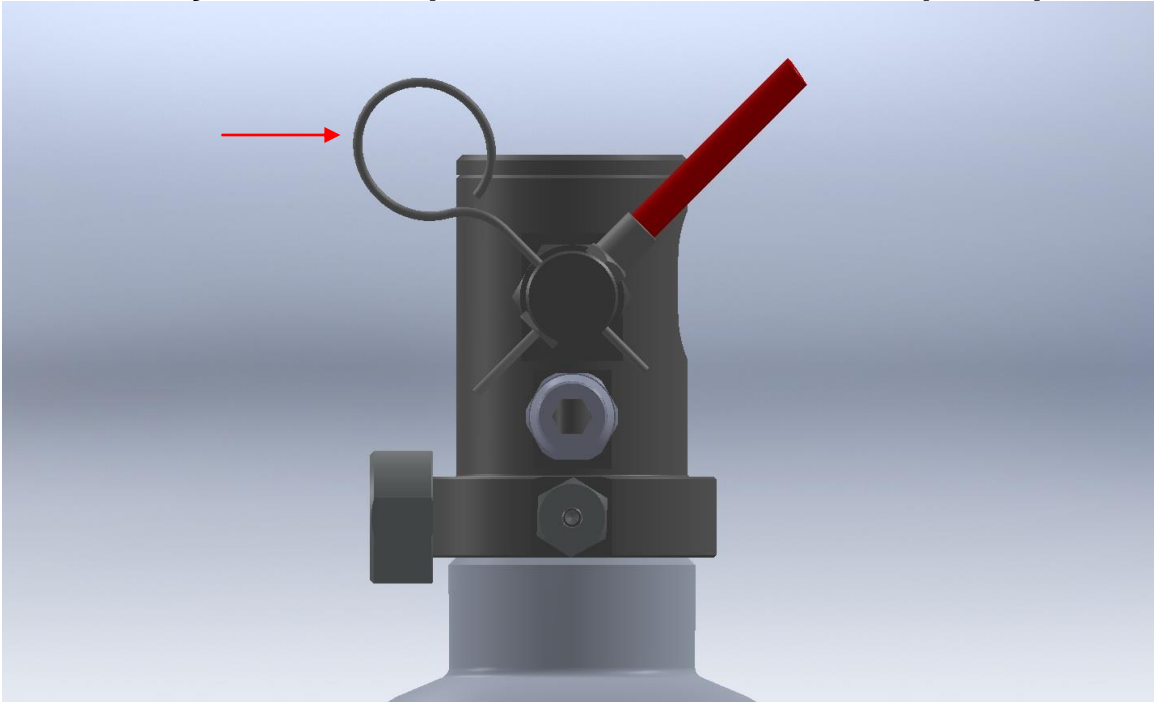

Wiring for electrical activation of 3 way head

SPA EXTREME ELECTRICAL SYSTEM WIRING SCHEMATIC

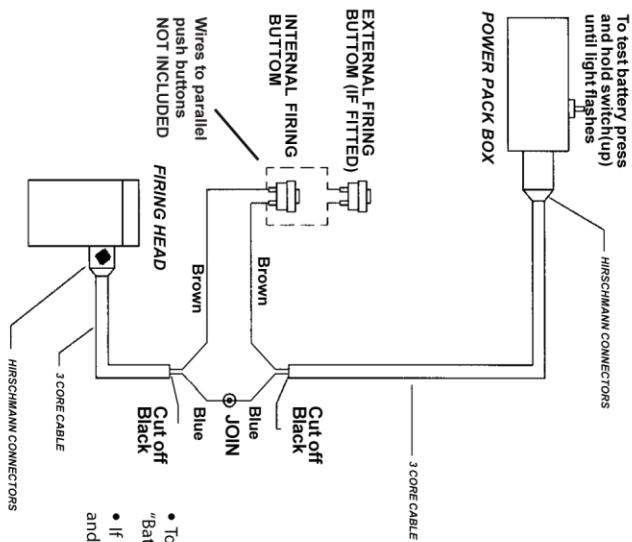

To test battery, press and hold switch (up) until light flashes

HIRSCHMANN CONNECTORS

POWER PACK BOX

EXTERNAL FIRING BUTTOM (IF FITTED)

INTERNAL FIRING BUTTOM

Wires to parallel push buttons NOT INCLUDED

FIRING HEAD

Cut off Black

Blue JOIN

3 CORE CABLE

HIRSCHMANN CONNECTORS

3 CORE CABLE

DO: Use the continuity test and battery test before each race

DO NOT: Do not run cables next to power cables or run in the same loom

- To test the battery, push and hold lever switch upwards in the "Battery Check" position until green light flashes.
- If the extinguisher tubing is to be removed, push the black collet in and pull the tubing out at the same time.

SPA ELECTRICAL DETAILS

The SPA system uses actuators to operate valves located within the pressurized container that contains the extinguishant. These are triggered remotely using a battery-powered power pack. In order to guarantee reliable operation the connectors used are 1P67 and the actuators used are of a military specification with the system / battery test electronics integrated into the power pack. The power pack electronics can test the continuity of the wiring, and also provides a high current pulse test to ensure system integrity before use. Unlike other systems, the battery test will not destroy or put an excessive drain on the battery during this critical test. These tests are performed using a three way switch on the power pack box and should be performed before each usage of the system, since the system is only as good as the battery that powers it and the integrity of the wiring loom and its connectors. To check the condition of the battery, push up and hold the switch on the power pack box. Every two seconds you will see a YELLOW - light flash. If the light flashes very dimly the battery must be replaced.

IF IN DOUBT REPLACE THE BATTERY!!!!

SYSTEM CONTINUITY CHECK

To check the continuity of the wiring, ensure that the switch on the power pack box is in the **SYSTEM INACTIVE** position to ensure that the extinguisher is not fired. Press the internal firing button and check that the RED light comes on, press the external firing button, and check that this also makes the RED light come on. The external button must be positioned close to the exterior master switch. DO ensure that the wiring does not run next to looms especially if they contain ignition or battery cables. DO ensure that any exposed connections that are likely to get water sprayed are protected. DO NOT allow cables to run through sharp edged apertures without protection. DO NOT fix cables to any surface that is likely to see excessive temperatures

Attachment of pull cable for automatic system



Bracket will need to be made to hold pull cable housing (outer sheath). Otherwise the pull cable will not work.

Configuration of automatic system without pull cable or for transportation

