

fireSense powered by
FireAde[®]



MULTI-FLO AFFF SYSTEMS

FIA HOMOLOGATION NUMBER: - EX.045.17

Installation Instructions

**Please read carefully before
attempting to install
your system.**



The Mill House, Tamworth Road, Packington Hayes
Nr Lichfield, Staffordshire, England WS14 9PN
Tel: 01543 434580 Fax: 01543 434581
E-mail: sales@spa-uk.co.uk
Web Site: www.spa-uk.co.uk

FireSense-Response powered by FireAde
AFFF Multi-flo Systems covered by this manual

- **FIA18-E4A** (UK part no. - MFE400A-4-A-FA)
- 4.0 Liter Electrical/Auto Aluminum

- **FIA18-E4S** (UK part no. - MFE400S-4-A-FA)
- 4.0 Liter Electrical/Auto Steel

- **FIA18-L4A** (UK part no. - MFM400A-4-FA)
- 4.0 Liter Mechanical Aluminum

- **FIA18-L4S** (UK part no. - MFM400S-4-FA)
- 4.0 Liter Mechanical Steel

- **FIA18-M4A** (UK part no. - MFM400A-4-A-FA)
- 4.0 Liter Mechanical/Auto Aluminum

- **FIA18-M4S** (UK part no. - MFM400S-4-A-FA)
- 4.0 Liter Mechanical/Auto Steel



The Mill House, Tamworth Road, Packington Hayes
Nr Lichfield, Staffordshire, England WS14 9PN. UK

Tel: 01543 434580 Fax: 01543 434581

E-mail: sales@spa-uk.co.uk

Web Site: www.spa-uk.co.uk

Thank you for purchasing a FireSense-Response AFFF Multi-flo System (which has been FIA homologated).

It is important that you read the following instructions carefully before attempting to install your fire suppression system.

The performance of this system will be affected if it is in anyway modified or tampered with it will void its homologation. Please ensure that should any parts need to be replaced, only genuine SPA FireSense-Response components are used.

Should you require any assistance, please do not hesitate in contacting SPA Design on 01543 434580.

IMPORTANT NOTE

The purpose of this along with any other vehicle fire suppression system is to provide sufficient time in which to control the fire to enable the occupants to leave the vehicle.

In ideal conditions, the fire will be extinguished completely but this can not be guaranteed. The main purpose is to curb the intensity of either an engine or cockpit fire to provide the means for the occupants to leave the vehicle or for outside assistance to be given.

C O N T E N T S

Fitting Instructions – Electrical System	Page 4-7
Fitting Instructions – Mechanical System	Page 8-10
Cylinder mounting	Page 11-12
Nozzles & Installation	Page 13-14
Tubing	Page 15
Kit Lists Component Check	Page 16
System Maintenance	Page 17
Bottle Dimensions	Page 18-20
Pipework & Nozzle layout	Page 21-23
Safety Data Sheet	Page 24
Agents	Page 25-28

Automatic Head

The new activation valve fitted to all models, with the exception of the -L4A and -L4S, within this new range of systems has a special safety feature that does not interfere with the standard operating procedure of the fire suppression system.

The automatic activation feature is a stand alone activation that will operate independent of user input at a temperature specified by the manufacturer.

IMPORTANT NOTE

The fire suppression system **requires input by the user**, by either mechanical (cable pull) or electrical (switch) to operate. ***The automatic activation is a safety backup only.*** It is **NOT** the primary means of activation. The primary means of activation is the driver using the cable pull or electrical switch depending on model purchased.

SPA FIRESENSE-RESPONSE ELECTRICAL SYSTEM WIRING SCHEMATIC APPLIES TO ALL ELECTRIC MODELS

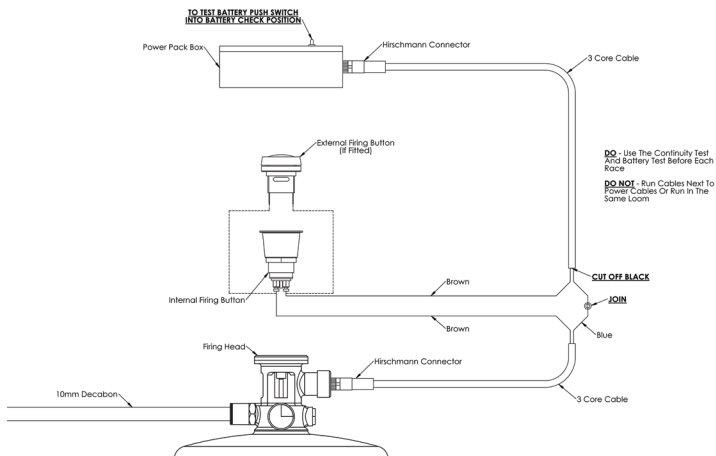

- To test the battery, push and hold control box switch upwards in the “Battery Check” position until yellow light flashes.
- If the extinguisher tubing is to be removed, push the black collet in and pull the tubing out at the same time.

RECOMMENDED: Use the continuity test and battery test before each race.

DO NOT: Run the cables next to power cables, or in the same loom.

ELECTRICAL FITTING INSTRUCTIONS

Unpack all parts and check components against the kit list, *which is located on page 16.*

- Remove bottle from mounting brackets if fitted by undoing the wing nuts. Decide the best position for the extinguisher – IT IS RECOMMENDED THAT THE BOTTLE SHOULD BE MOUNTED IN THE FORE AND AFT DIRECTION OF THE VEHICLE.
The extinguisher label, detailing the contents and the pressure gauge should be clearly visible for inspection, Mount the retaining brackets securely to the vehicle and put the bottle back into place.
(Refer to Figure 3.)
- Mount the power pack in a clearly visible position.
- Switch with red plastic shroud to be fitted in the cockpit so that it is in easy reach of both the driver and/or co-driver when sitting in the normal driving position and wearing fully fastened seat-belts.
- The other switch with flexible red membrane (waterproof) is to be fitted to the outside of the vehicle, close to the exterior master switch (for activation by the Marshals).
- Once the system has been wired as per wiring diagrams (*refer to Figure 1 / 2*), the following tests should be carried out to check the system is fitted correctly and will operate when required. (*See Page 5*)

SPA DESIGN FIRESENSE-RESPONSE ELECTRICAL DETAILS

The SPA FireSense-Response system uses actuators to operate valves located within the pressurized container that contains the extinguishant. These are triggered remotely using a battery-powered power pack.

In order to guarantee reliable operation the connectors used are 1P67 and the actuators used are of a military specification with the system / battery test electronics integrated into the power pack.

The power pack electronics can test the continuity of the wiring, and also provides a high current pulse test to ensure system integrity before use. Unlike other systems, the battery test will not destroy or put an excessive drain on the battery during this critical test. These tests are performed using a three way switch on the power pack box and should be performed before each usage of the system, since the system is only as good as the battery that powers it and the integrity of the wiring loom and its connectors.

To check the condition of the battery press and hold up the switch on the power pack box in battery check position. **Every two seconds you will see a YELLOW** light flash.

If the light flashes very dimly the battery must be replaced.

IF IN DOUBT REPLACE THE BATTERY !!!!

To check the continuity of the wiring, ensure that the switch on the power pack box is in the **SYSTEM INACTIVE** position to ensure that the extinguisher is not fired.

Press the internal firing button and check that the **RED** light comes on, press the external firing button, and check that this also makes the **RED** light come on.

The external button must be positioned close to the exterior master switch.

When you are ready to race after all these checks push switch into system armed position, **the control box will not illuminate in the system armed position** if either internal or external switches are pressed the system will activate.

DO ensure that the wiring cables do not run next to looms especially if they contain ignition or battery cables

DO ensure that any exposed connections that are likely to get water sprayed are protected.

DO NOT allow cables to run through sharp edged apertures without protection

DO NOT fix cables to any surface that is likely to see excessive temperatures.

MECHANICAL CABLE SETUP

LEVER VALVE

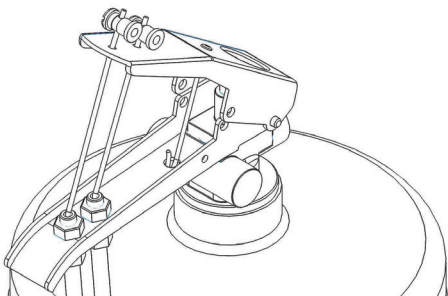

MECHANICAL AUTO HEAD

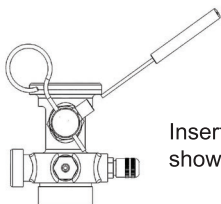

Insert cable pull into hole location as shown.

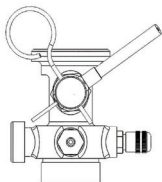

Make sure Cable is secure.

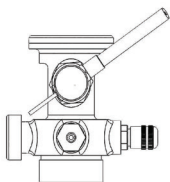

Once cable is secure, remove safety pin before race, when race is finished replace safety pin.

MECHANICAL SYSTEM

Unpack all parts and check components against the kit list, *which is located on page 16.*

- Remove bottle from mounting brackets if fitted by undoing the wing nuts. Decide the best position for the extinguisher – IT IS RECOMMENDED THAT THE BOTTLE SHOULD BE MOUNTED IN THE FORE AND AFT DIRECTION OF THE VEHICLE. The extinguisher label, detailing the contents and the pressure gauge should be clearly visible for inspection, Mount the retaining brackets securely to the vehicle and put the bottle back into place. (*refer to Figure 3*).
- Insert the end of the Decabon tube into the push-in fitting on the lever-valve and lay the length of the tube from the cylinder to the chosen location; plug the nozzle onto the free end of tube and orientate this to point the nozzles onto anticipated fire sources.
- Mount the 6-ft cable in the cockpit within reach of the driver and / or co-driver when sitting in the normal driving position wearing seat-belts. The other end of the cable is to be threaded through one of the adjusting screws on the handle of the lever-valve (on the cylinder). Then threaded through one of the holes in the other handle and the clamp screw made secure on cable against the underside in such a way that movement of the red pull handle will close the handles of the lever-valve, BUT allowing 6mm of free-play. CAUTION: do not allow this testing to actually move the handles or the valve may open and release the extinguishant (keep the safety pin in place).

- Mount the 12-ft cable on the outside of the vehicle (close to the exterior master switch is the recommended position). Lay the cable inside the vehicle and connect to the lever-valve as above.

- Pull cables should be fitted in such a way that no kinks or 'S' bends are formed, which could cause malfunction.

- Removing the safety pin from the lever-valve leaves the system ready for use.

- ***SAFETY WARNING: Failure to remove safety pin before going on track, will render the system inoperable when required.***

EXTINGUISHER MOUNT BRACKET

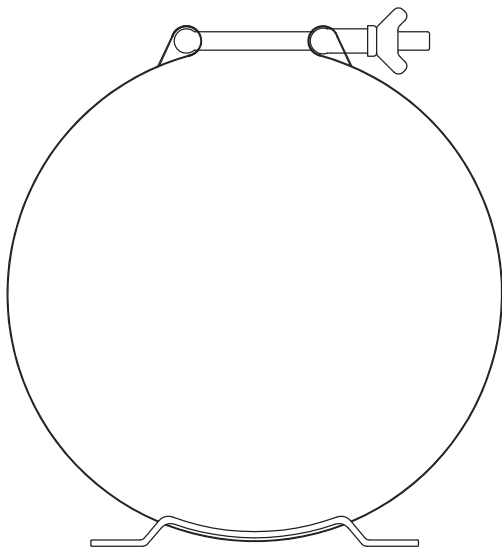

SPAT 126 - 6" Cylinder Retaining Bracket

ANTI-TORPEDO MOUNT MANDATORY ON ALL FIA SYSTEMS

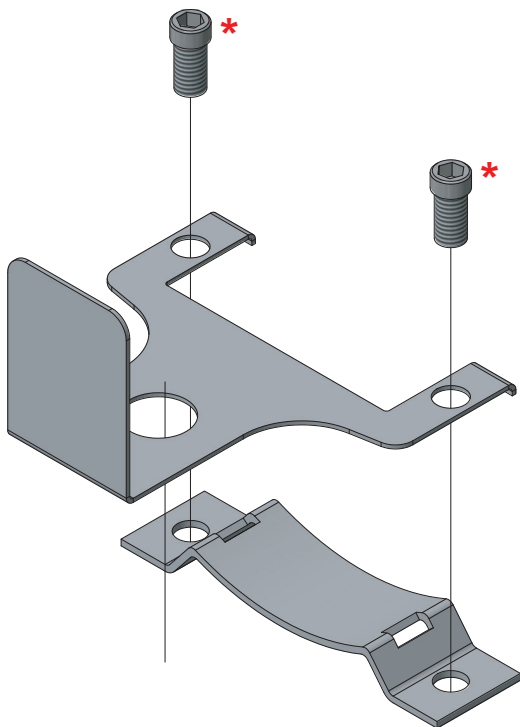

SP 319 - Anti-Torpedo Bracket - FIA

** - Bolts not included*

A.F.F.F. NOZZLES

It is important that all of the nozzles provided in the fire system kit are used.

The nozzles will produce a fine atomized spray with the AFFF emerging as a milky white foam substance, which forms a film barrier starving the fire of oxygen. This foam spray has the capability of excellent fire out times and has a cooling effect, which can control re-ignition.

When locating the nozzles it should be noted that there is a 90° cone with a 1/2 meter spray.

Nozzles should not simply be supported by their own pipe work. Where necessary support the nozzle in a bracket.

Nozzles should be checked for damage/possible blockage. They should also be tested to ensure that they are in good working order.

Depending on the class of racing/rallying,(which is the competitors responsibility) e.g. International rallying, which needs a 4lt system, the engine bay must have 2 nozzles installed, with one each side of the motor and 2 nozzles installed in the cockpit.

For open cars, the system must include two nozzles one should be aimed at the drivers midriff with special care being taken not to spray into the drivers face.

For saloon /closed cars 2 nozzles must be fitted within the cockpit area. Nozzles should be fitted either to the top of the roll bar main hoop (door B pillar) pointing inwards and downwards towards the foot of the diagonally opposite front roll bar hoop base (door A post) or either under the dashboard aiming at the drivers midriff.

These are guide lines for competitors using SPA Design fire suppression systems

IF IN DOUBT, ASK!!!

Example of Cockpit nozzle location.

Nozzle location refer to Page

13

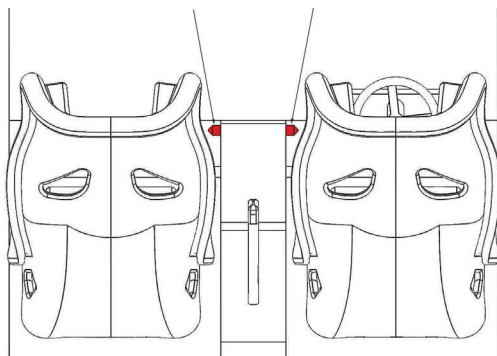

EXAMPLE OF ENGINE NOZZLE LOCATION

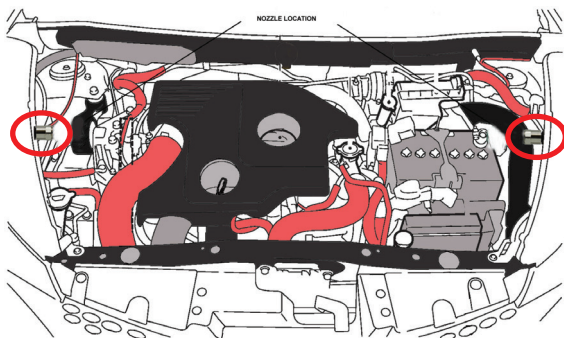

TUBING

Each FireSense-Response System kit is supplied with Decabon tubing which is a coated aluminium tube which can be molded and flexed to suit this application. The FireSense-Response system has been designed and homologated using 10mm & 8mm dia tube. DO NOT substitute this tube for any other type.

TUBE CONNECTIONS

All fittings for tube to nozzles and bottle are of the push-in type. Insert the tube into the fitting, push firmly until it clicks. Once in you should not be able to pull it out.

To remove the tubing, push the tube into the fitting and at the same time push/pull the black collett back towards the fitting and then pull the tube from the fitting.

KIT LISTS

Electrical Systems:

- **FIA18-E4A**

- **FIA18-E4S**

Contain the following:

- 2x SPAT 126 - 6" Bottle Mounts
- 2x SP 319 - Anti-Torpedo Mounts
- 4x SP 031 - 8mm AFFF Nozzle
- 2x SP 028 - 8mm Tee Fitting
- 1x SP 029 - 8mm Bulkhead Fitting
- 1x SP 183 - 10mm-8mm Y Connector
- 1x SP 017 - Large E Sticker
- 1x SP 129 - Small E Sticker
- 4.5m SP 032 - 8mm Decabon Tubing
- 0.5m SP 072 - 10mm Decabon Tubing
- 1x SP 007 H - Power Pack (Hirschman style)
- 2x SP 005 H - Plug & Lead (Hirschman style)
- 1x SP 011 - Internal Fire Button
- 1x SP 012 - External Fire Button (waterproof)

Mechanical Systems:

- **FIA18-L4A**

- **FIA18-L4S**

- **FIA18-M4A**

- **FIA18-M4S**

Contain the following:

- 2x SPAT 126 - 6" Bottle Mounts
- 2x SP 319 - Anti-Torpedo Mounts
- 4x SP 031 - 8mm AFFF Nozzle
- 2x SP 028 - 8mm Tee Fitting
- 1x SP 029 - 8mm Bulkhead Fitting
- 1x SP 183 - 10mm-8mm Y Connector
- 1x SP 017 - Large E Sticker
- 1x SP 129 - Small E Sticker
- 4.5m SP 032 - 8mm Decabon Tubing
- 0.5m SP 072 - 10mm Decabon Tubing
- 1x SP 018 - 6ft Pull Cable
- 1x SP 019 - 12ft Pull Cable

MAINTENANCE

To ensure maximum possible performance from your SPA Fire FireSense Response system, the following checks and maintenance procedures should be carried out.

- Regularly check the pressure gauge to ensure they are in the green section.
- Regularly check nozzles for debris or any obstructions externally and internally.
- Regularly check the integrity of the pipe work and fitting.
- Regularly check the cylinder for physical damage or corrosion.
- Regularly check the mounting brackets, retaining straps and bolts are secure.
- Regularly check your power pack control box and condition of the internal alkaline battery, the battery should be changed preferably every 6 months or if system has been fired off.
- Regularly check your wiring and electrical connectors for any damage.
- If the system has been activated the nozzles and pipe work should be washed through with fresh water and then cleared with an air line if possible to avoid residue of the extinguishant crystallizing in the pipe work or nozzles.
- Your SPA fire suppression system must be serviced every 2 years, a service due date is written on the contents label located on your cylinder. It is up to you to ensure the services are carried out at the correct intervals.
- If your system has been discharged or requires a 2-year service you must return it to SPA or an approved agent of SPA fire suppression systems.

NOTES

Please ensure that you monitor the following, as you **may not** pass scrutineering **if**;

- The needle on the gauge is in the red section
- The bottle contents label is worn, damaged or unreadable.
- The unit is not within the service date.
- The system is in a poor condition

BOTTLE DIMENSIONS

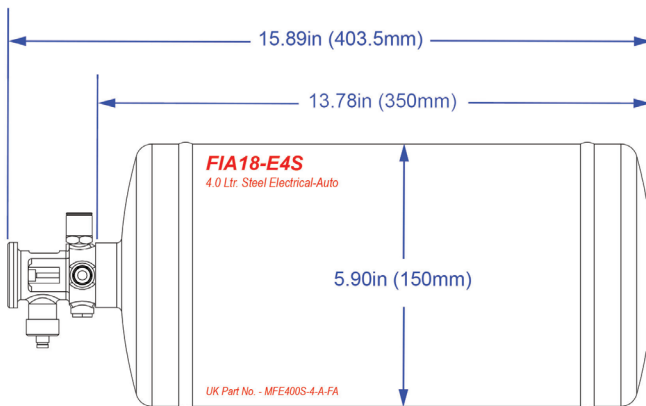
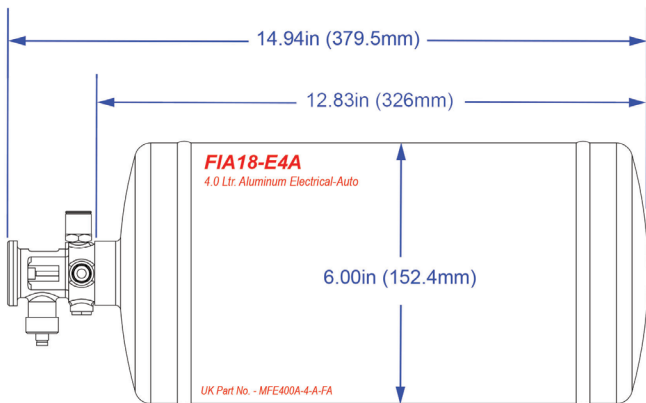

BOTTLE DIMENSIONS

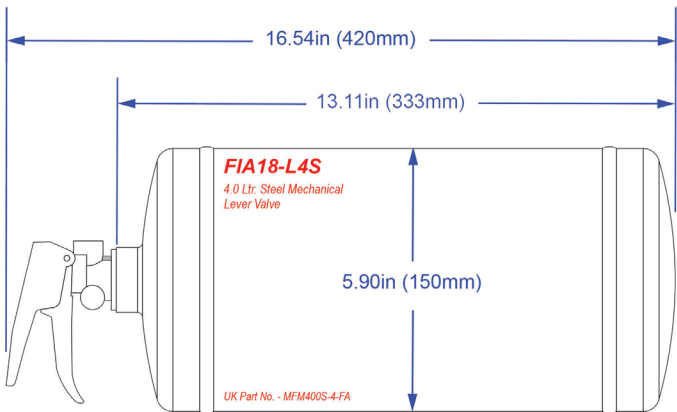
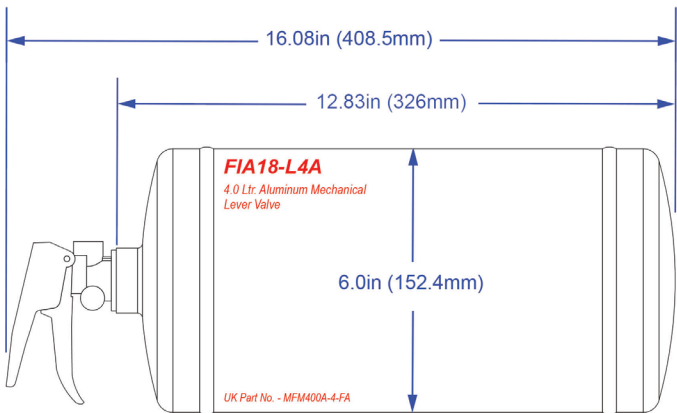

BOTTLE DIMENSIONS

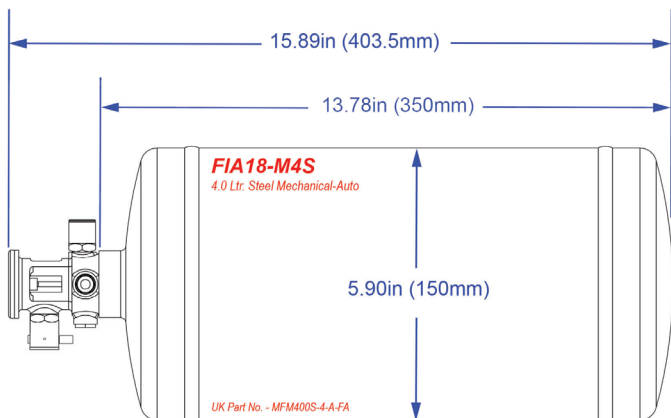
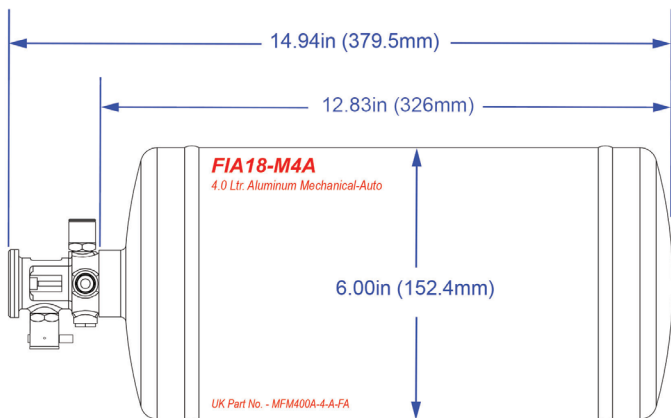

Nozzle & Tubing Layout

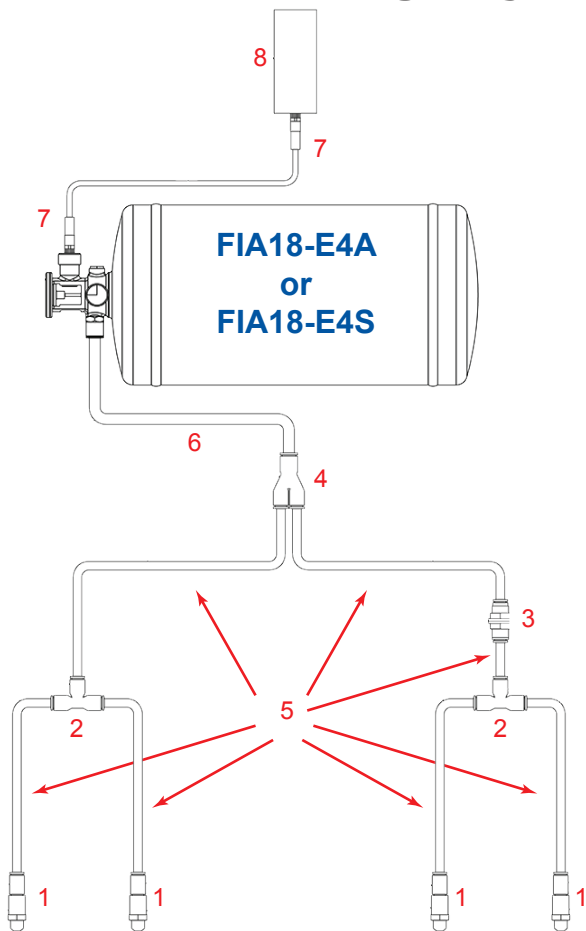

Diagram No.	Part No.	Description	Qty. per Kit
1	SP 031	AFFF Nozzle, 8mm	4
2	SP 028	Tee Fitting, 8mm	2
3	SP 029	Bulkhead Fitting, 8mm	1
4	SP 183	Y-Connector, 10mm-8mm	1
5	SP 032	Tubing, 8mm (per Meter)	4.5
6	SP 072	Tubing, 10mm (per Meter)	0.5
7	SP 005 H	Plug & Lead, Hirschman Style	2
8	SP 007 H	Power Pack, Hirschman Style	1

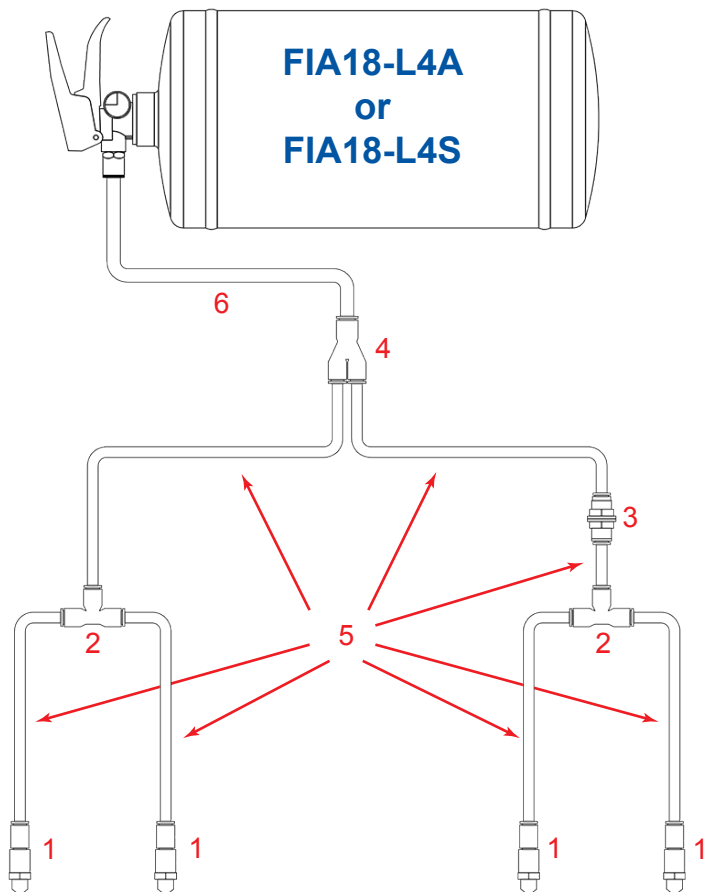

Diagram No.	Part No.	Description	Qty. per Kit
1	SP 031	AFFF Nozzle, 8mm	4
2	SP 028	Tee Fitting, 8mm	2
3	SP 029	Bulkhead Fitting, 8mm	1
4	SP 183	Y-Connector, 10mm-8mm	1
5	SP 032	Tubing, 8mm (per Meter)	4.5
6	SP 072	Tubing, 10mm (per Meter)	0.5

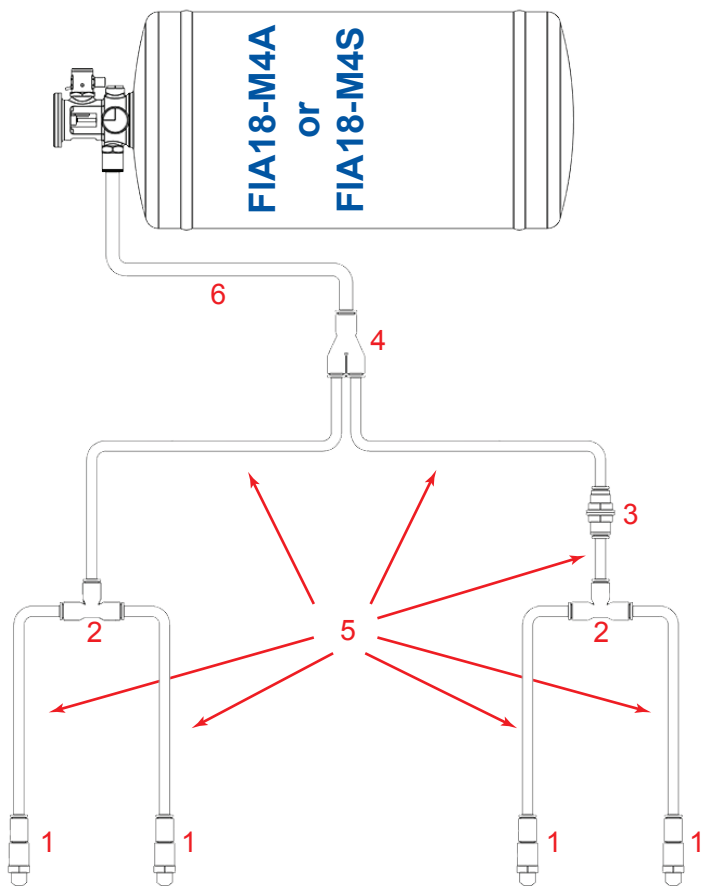

Diagram No.	Part No.	Description	Qty. per Kit
1	SP 031	AFFF Nozzle, 8mm	4
2	SP 028	Tee Fitting, 8mm	2
3	SP 029	Bulkhead Fitting, 8mm	1
4	SP 183	Y-Connector, 10mm-8mm	1
5	SP 032	Tubing, 8mm (per Meter)	4.5
6	SP 072	Tubing, 10mm (per Meter)	0.5

FireAde® AR-AFFF

Environmentally formulated, FireAde® AR-AFFF is the newest generation in Alcohol-Resistant Aqueous Film Forming Foam. Using Green Agent Technology™, the FireAde® AR-AFFF prevents environmental hazards and demonstrates our long term commitment to the environment. FireAde® AR-AFFF produces a stable, heat resistant and self-sealing blanket; it will not clog, gum, or corrode foam systems and equipment, providing an unparalleled performance. FireAde AR-AFFF contains ZERO hazardous materials and has a reduced viscosity when compared to a majority of AR-AFFF products. This reduction in viscosity permits FireAde® AR-AFFF to be used in all types of foam portioning systems, in-line eductors, and standard foam equipment without adverse effects.

- Environmentally Formulated
- Organic Compounds
- Zero Hazardous Chemicals
- Encompasses Water Based and
- Food Grade Ingredients
- Contains no ingredients reportable under the Superfund amendments and Reauthorization Act (SARA) Title III, Section 313 of 40 CFR-372 or Comprehensive Environmental Response, Compensation, and Liability Act (CERCLA).

SAFETY DATA SHEET FOR AFFF

APPLICATION:	Motorsports Industry - To include single seaters, saloon, and other racing cars.
CONTENTS:	FireAde AR-AFFF Firefighting Foam, 3x3 Low Viscosity, Water
APPEARANCE:	Natural Amber Liquid. Faint, pleasant clean odor
Ph:	7.5 - 8.5
VISCOSITY:	900 cps
WATER SOLUBILITY:	Soluble
Min. STORAGE TEMP:	35°F (2°C)
Max. STORAGE TEMP:	120°F (49°C)
EFFECTS of FREEZE:	None

**NORTH AMERICAN AUTHORIZED SERVICE CENTERS
for
SPA FireSense® fire bottles**

CALIFORNIA

Competition Touring Cars
(SPA Fire Sense Service Center)
29107 Arnold Dr, Unit E-3
Sonoma, California 95476
Phone: 707-933-8282
Email: brian@competitiontouringcars.com

Streetwise
(SPA Fire Sense Service Center)
31441 Santa Margarita Pkwy A162
Rancho Santa Margarita, California 92688
Phone: 949-459-0744
Email: doug@streetwiseparts.com

Werks II Motorsport
(SPA Fire Sense Service Center)
918 Chestnut St.
Burbank, California 91506
Phone: 818.845.2530
Email: sales@werks2.com

FLORIDA

Wine Country Motor Sports-East
(SPA FireSense Service Center)
1003 Jupiter Park Lane, Suite 4
Jupiter, Florida 33458
Phone: 866-320 3278
Email: east@winecountrymotorsports.com

GEORGIA

Discovery Parts
(SPA Fire Sense Service Center)
20 Duck Thurman, Building E Ste. 2
Dawsonville, GA 30534
Phone: 888.748.RACE(7223)
Email: ron.z@discoveryparts.com

ILLINOIS

Hoerr Racing Products
(SPA Fire Sense Service Center)
4802 Competition Lane
Peoria, Illinois 61615
Phone: 866.851.RACE
Email: info@hrpworld.com

INDIANA

Racer Parts Wholesale
(SPA Fire Sense Service Center)
411 Dorman Street
Indianapolis, Indiana 46202
Phone: 800-397-7815
Email: info@racerpartswholesale.com

NEW JERSEY

Stable Energies
(SPA Fire Sense Service Center)
175 Passaic St.
Garfield, New Jersey 07026
Phone: 973.773.3177
Email: info@stableenergies.com

OREGON

Racing Fire Systems
(SPA Fire Sense Service Center)
38338 Miller St.
Sandy, Oregon 97055
Phone: 503.784.1878
Email: service@racingfiresystems.com

TEXAS

G-Speed, LLC
(SPA Fire Sense Service Center)
215 Performance Lane, Building I (MotorSport Ranch)
Cresson, Texas 76035
Phone: 817-512-4780
Email: sales@performancespeedtech.com

VIRGINIA

OG Racing
(SPA Fire Sense Service Center)
22585 D Markey Court
Sterling, Virginia 20166
Phone: 800-934-9112
Email: info@ogracing.com

WISCONSIN

Pegasus Auto Racing
(SPA Fire Sense Service Center)
2475 South 179th Street
New Berlin, Wisconsin 53146-2150
Phone: 1-800-688-6946 (US & Canada)
Email: custsvc@pegasusautoracing.com

CANADA

Jon Nichols Motorsport
(SPA Fire Sense Service Center)
145-20 Ave
Lachine, QC, CANADA H8S 3S8
Phone: 888-634-9656
Email: info@jonnichols.com

SPA FireSense® Spare Parts & Optional Fittings

Activation Spares

Electrical



SP 005 H
Hirschman Plug & Lead



SP 007 H
Hirschman Power Pack



SP 011
Internal Fire Button



SP 012
External Fire Button
(Waterproof)

Mechanical



SP 018
6ft. Pull Cable



SP 019
12ft. Pull Cable

Mounting Spares



SPAT 126
Bottle Mount



SP 319
Anti-Torpedo Brackets (Pair)

SPA FireSense® Spare Parts & Optional Fittings

Fittings & Tubing Spares



SP 028
8mm Tee Fitting



SP 029
8mm Bulkhead Fitting



SP 031
8mm AFFF Nozzle



SP 183
10mm-8mm Y-Connector



SP 026
1/8bsp to 6mm tube
(fitting for SP 031 Nozzle)



SP 194
1/4bsp to 10mm tube
(for firing head/lever valve)



SP 032
8mm Decabon Tubing
(per foot)



SP 072
10mm Decabon Tubing
(per foot)

Optional Fittings & Misc.



SP 039
8mm Union



SP 054
8mm Y-Connector



SP 104
8mm 90° Fitting



SP 133
8mm Decabon Clips



SP 142-L
Safety Pin Lanyard



SP 136
Tubing Cutter



SP 075
AFFF Nozzle Nut



SP 017
Large E Sticker



SP 129
Small E Sticker

NOTES

NOTES



North American Importer for SPA Design

SPA Technique, Inc.

8225 Indy Lane

Indianapolis IN 46214

p:317.271.7941 f:317.271.7951

info@spatechnique.com

www.spatechnique.com



Industry Leader in Fire Suppression since 1989

The Mill House, Tamworth Road, Packington Hayes

Nr Lichfield, Staffordshire, England WS14 9PN

Tel: 01543 434580 Fax: 01543 434581

E-mail: sales@spa-uk.co.uk

Web Site: www.spa-uk.co.uk