

45BBL

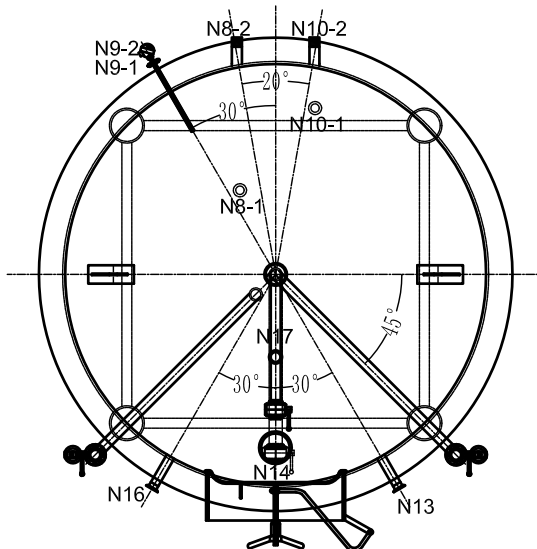
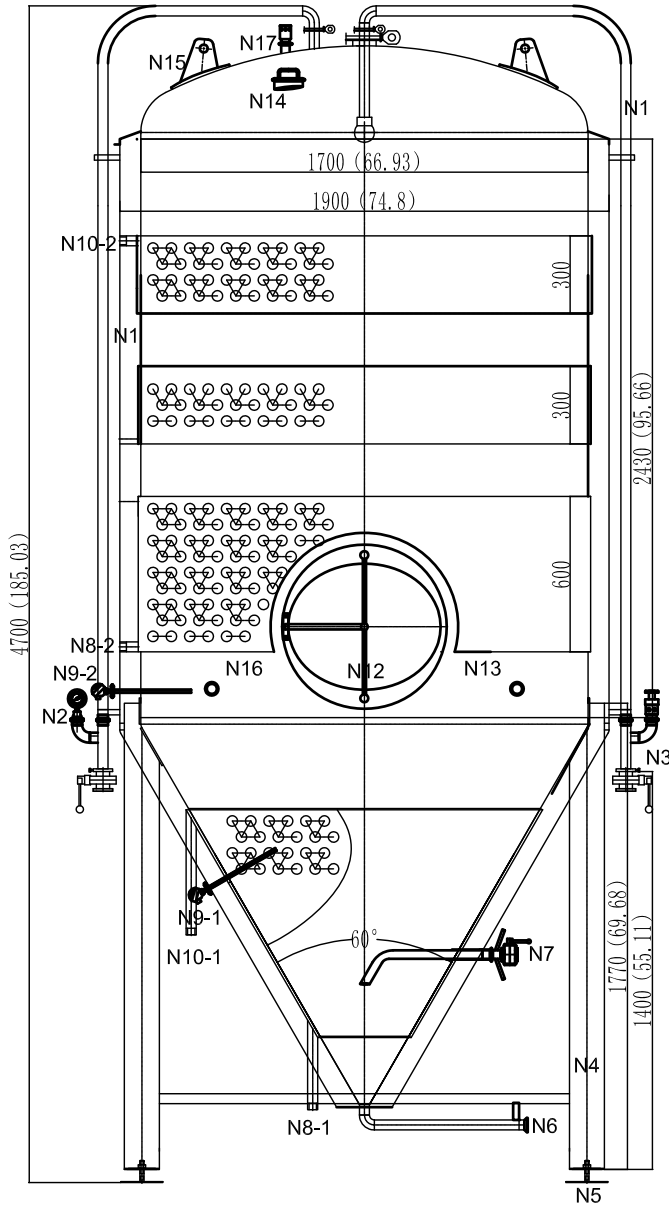

Technique parameter

	Interior	Jacket
Material	SUS304	SUS304
Working pressure Mpa	0.15	0.2
Design pressure Mpa	0.3	0.4
Tank Size mm	∅1800*3850	
Quantity (Nos)	2	
Cooling mode	Alcohol water cooling	
Insulation material	Polyurethane	
Insulation thickness mm	100	
Outer tank thickness mm	4.0	
Inter tank thickness mm	3.0	
Cover thickness mm	4.0	
Cone angle	60°	
Cone volume BBL	7.92	
Cylinder volume BBL	29.53	
Cover volume BBL	3.89	
Effective volume BBL	30	
Total volume BBL	41.34	

Specification

Icon	Size	Connecting style	Name
N17	∅38mm	Clamp	Safety valve
N16	∅38mm	Clamp	Sampling valve
N15			Hoisting ring
N14	∅102mm	Clamp	Dry hops adding port
N13	∅38mm	Thread	Thermometer
N12	∅580*480mm	Quick-open	Manhole door
N11	∅38mm	Clamp	Cleaning ball
N10-1/2	∅32mm	Thread	Ice water outlet
N9-1/2	∅10mm	Thread	Temperature probe
N8-1/2	∅32mm	Thread	Ice water inlet
N7	∅51mm	Clamp	Racking arm
N6	∅51mm	Clamp	Drainage valve
N5	M24mm	Thread	
N4	∅133mm	Welding	Supporting leg
N3	∅38mm	Clamp	Pressure relief valve
N2	∅38mm	Clamp	Pressure gauge
N1	∅38mm	Clamp	CIP pipe

45BBL
Fermentation Tank

Assembly
Diagram