

30BBL

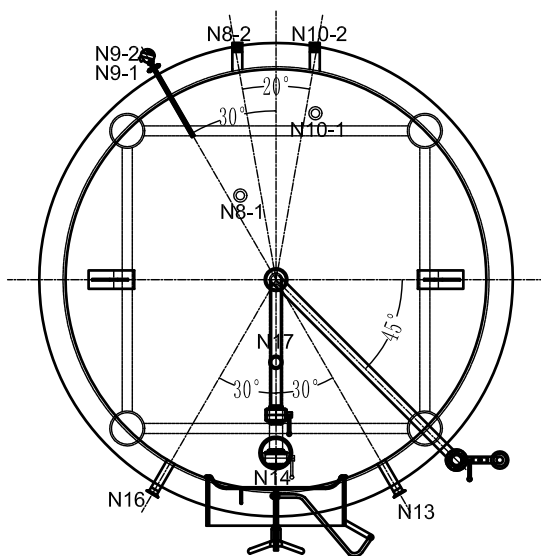
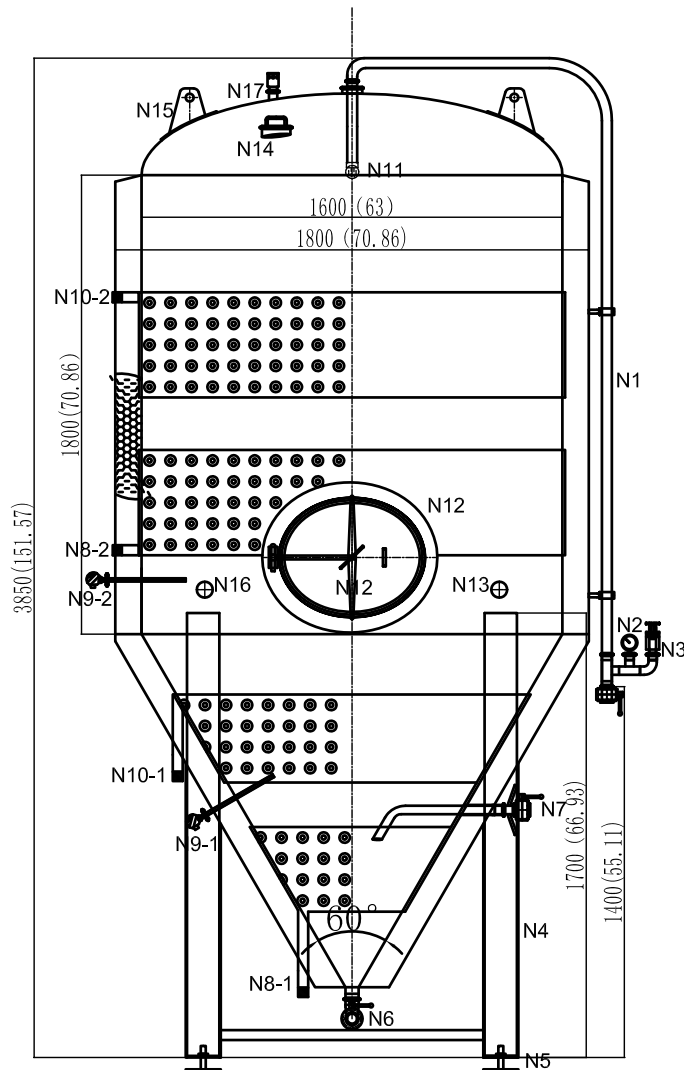

Technical Specs

	Interior	Jacket
Material	SUS304	SUS304
Working pressure psi	21.8	29
Design pressure psi	43.5	58
Tank Size	ø70.86"*151.57"	
Quantity (Nos)	1	
Cooling mode	Glycol	
Insulation material	Polyurethane	
Insulation thickness	4"	
Outer tank thickness	0.157"	
Inter tank thickness	0.118"	
Cover thickness	0.157"	
Cone angle	60°	
Cone volume BBL	7.92	
Cylinder volume BBL	29.53	
Cover volume BBL	3.89	
Effective volume BBL	30	
Total volume BBL	41.34	

Specification

Icon	Size	Connecting style	Name
N17	Ø1.5"	Clamp	Safety valve
N16	Ø1.5"	Clamp	Sampling valve
N15			Hoisting ring
N14	Ø4"	Clamp	Dry hops adding port
N13	Ø1.5"	Thread	Thermometer
N12	Ø22.8"*18.9"	Quick-open	Manhole door
N11	Ø1.5"	Clamp	Cleaning ball
N10-1/2	1 NPT	Thread	Gylcol outlet
N9-1/2	½ NPT	Thread	Temperature probe
N8-1/2	1 NPT	Thread	Gylcol inlet
N7	Ø2"	Clamp	Racking arm
N6	Ø2"	Clamp	Drainage valve
N5	M24mm	Threat	
N4	Ø5.24"	Welding	Supporting leg
N3	Ø1.5"	Clamp	Pressure relief valve
N2	Ø1.5"	Clamp	Pressure gauge
N1	Ø1.5"	Clamp	CIP pipe

Brewhouse Solutions LLC

30BBL			
Fermentation Tank			
		Assembly Diagram	