

# whirlpool tank

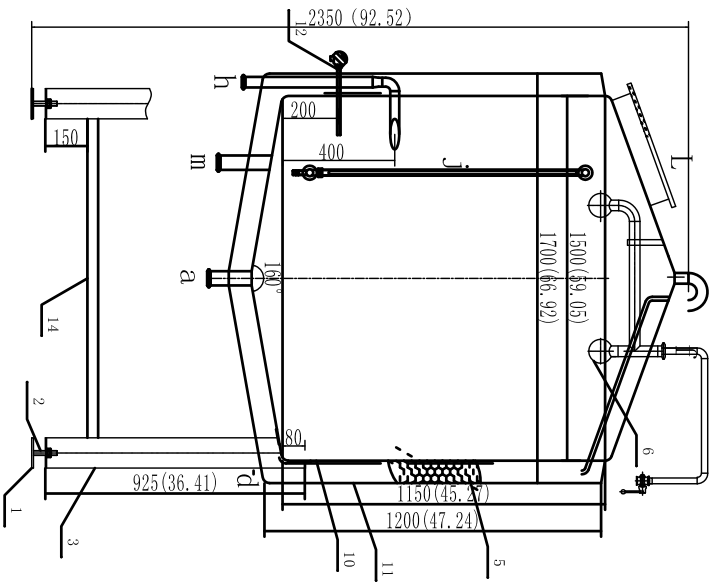

## Orifice

Symbol	Nominal size	Connection mode	Use
a	ø51	Clamp	Drainage port
b	NP720		Temperature thermowell
c	ø19		Condensate
d	ø400		Manhole door
e	ø38	Clamp	CIP inlet
f	ø38	Clamp	Junction box
g	ø38	Clamp	Whirlpool inlet
h	ø38	Clamp	Level gauge
i	ø38	Clamp	Hot water inlet
j	ø38	Clamp	Wort outlet

## Production requirement

1. Effective volume: 15BBL; Gross volume: 20BBL;
2. Construction SUS 304 food grade stainless steel, all pipes are sus304
3. Tank will be tested and detected in the NDT room after finished, to ensure no leakage.
4. Steam jackets will do water pressure testing, testing pressure: 0.4Mpa;
5. All tanks will be pressure protection 48hours before leaving from factory;
6. TIG full welding by water to ensure uniform and long life, stainless steel 308L welding wire
8. All tanks are mirror polishing inside, all ports are recessed type.
9. Total weight: 350kgs

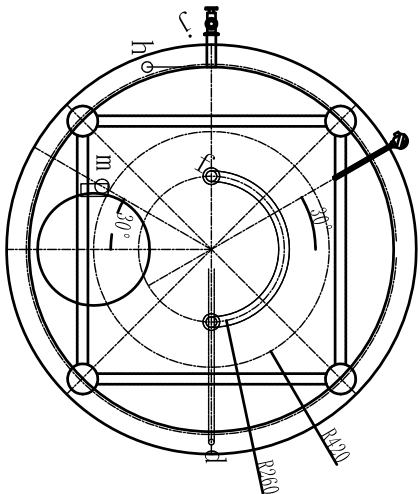

Note: Quantity: 1

14	Leg support	ø38×L=1.5	4	06Cr19Ni10	
13			1	06Cr19Ni10	
12	Temperature probe	NP720-ø13×L=1.5 L=250	1	06Cr19Ni10	
11	Outer tank	ø2	1	06Cr19Ni10	
10	Inner tank	ø3	1	06Cr19Ni10	
9					
8	Support of separating pipe		1	06Cr19Ni10	
7	ø2 width	20	1	06Cr19Ni10	
6	Cleaning ball	ø38	2	06Cr19Ni10	
5	Insulation Materials	0.22m³	1	Rock wool	
4	Supporting leg	ø133×3	4	06Cr19Ni10	
3	Adjusting bolt	M20×80	4	06Cr19Ni10	
2	Footpad	110×88	4	06Cr19Ni10	
1					
No.	Name	quantity	material	Note	

## 15BBL Whirlpool tun

Design	Stage remark	Weight	scale
Check			
Audit			
Approve	Total page		