

# 10BBL CLT

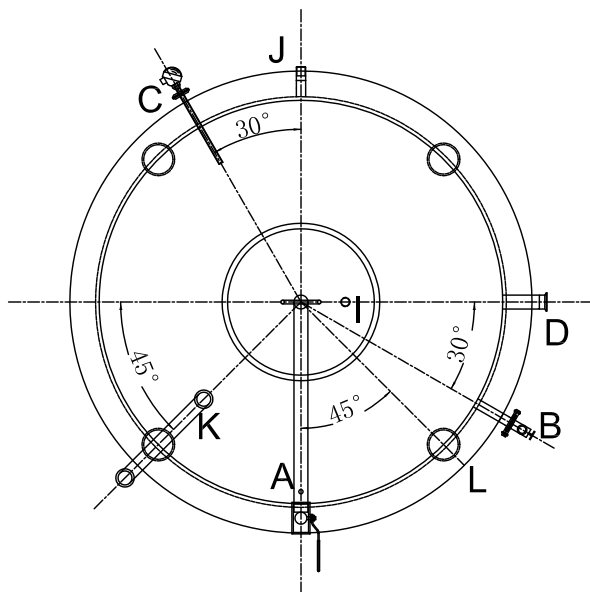
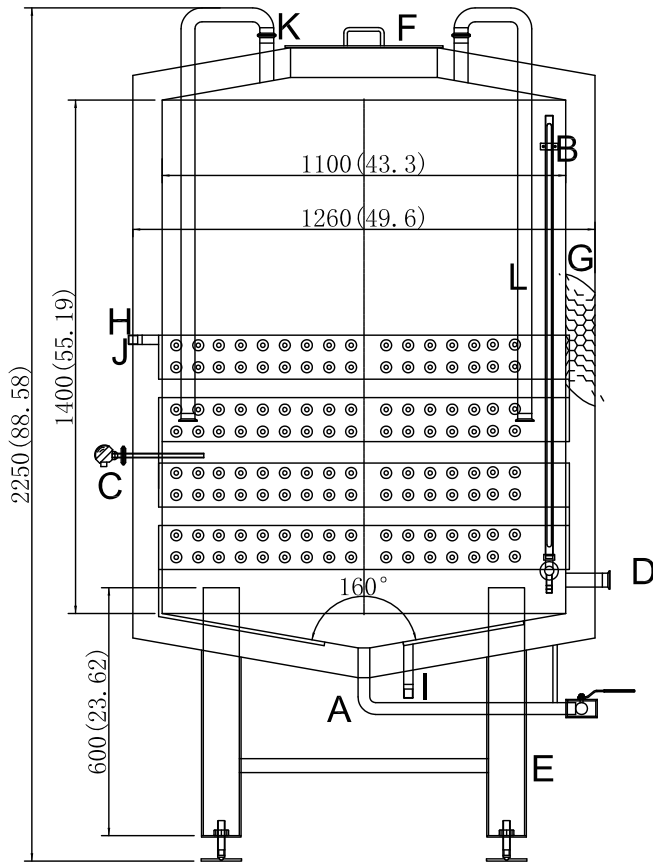

## Technical Specs

	Interior	Jacket
Material	SUS304	SUS304
Working pressure psi	Ordinary pressure	29
Tank Size	ø49.6"*88.6"	
Quantity (Nos)	1	
Heating way	Steam heating	
Storage medium	Cold water	
Insulation material	Polyurethane	
Insulation thickness	3.15"	
Outer tank thickness	0.079"	
Inter tank thickness	0.118"	
Cone angle	160°	
Effective volume BBL	10	
Total volume BBL	11.1	

## Specification

Icon	Name	Connecting style	Size
L	CIP pipe	Clamp	ø1.5"
K	Add water entry	Clamp	ø1.5"
J	Cold outlet	Thread	ø1.5"
I	Cold inlet	Thread	ø1.5"
H	Cold jacketed	Welding	
G	Insulation thickness		3.15"
F	Manhole door	Quick-open	ø15.75"
E	Supporting leg	Welding	ø4.25"
D	Cold water outlet	Clamp	ø1.5"
C	Temperature probe		½NPT
B	Level gauge		
A	Drainage outlet	Thread	ø1.5"

## Brewhouse Solutions LLC

10BBL Cold water tank		
	Assembly Diagram	