

WARNING

Please read this safety and instruction manual in its entirety before using this forge.
This will ensure safe and proper procedures when handling this product.

The **Mr Volcano® Hero** forge reaches temperatures of up to **2600°F** and requires best safety and operating precautions.

Propane: Burning of propane produces carbon dioxide which can be fatal when an excess amount is inhaled. To avoid potential carbon dioxide poisoning, only use the forge in a well-ventilated area or outdoors.

Burn Hazard: When using the forge, the **surface** temperature of the forge and components will reach up to **600°F**. Do not touch any part of the forge while the forge is heating up or hot. Do not place the forge near a wall or flammable material. **Allow for the forge to fully cool down before handling.**

FLAME HAZARD



HEALTH HAZARD



Personal Protection Equipment is required when handling Rigidizer, Satanite Refractory, and Insulation Blanket during installation.

Rigidizer: Do not drink. Avoid contact with skin or clothes, it will mildly dry skin and it will harden clothes.

Satanite Refractory: A N95 mask and gloves is required the powder form of Satanite Refractory

Insulation Blanket: This forge comes with **Superwool XTRA LBP** insulation blanket. See Page 2 for all the benefits of this insulation blanket. However, we still encourage and recommend our customers to wear gloves and respirator when handling the insulation blanket.

EYE PROTECTION



HAND PROTECTION



RESPIRATORY



The various uses of this product are outside our control; we can assume no liability for damages incurred through use or misuse of this product.

Failure to follow instructions and generally acceptable practices may result in **personal injury or death and damage to property.**

Follow the local laws, regulations, and codes in your place of business or home.

GOOD NEWS!

This forge comes with **Superwool XTRA** insulation!
A **major generational leap** in the thermal blanket insulation industry.
It emits **ZERO** crystalline silica, and the fibers are **Low Bio-Persistent**.

Containing high heat safely has been an endeavor put forth before scientists, chemists, and engineers for decades. The existing material used, Refractory Ceramic Fiber (RCF) Blanket, made from Kaolin, came with negative health concerns. RCF, when heated above 1800°F, releases crystalline silica which are hazardous to our respiratory system. The second health concern was the airborne fibers. RCF fibers are not low bio-persistent, meaning they stay in the body for a long period of time, which could lead to health issues.

When forging, temperatures reach well above 1800°F. Forge manufacturers for years would line the forge with RCF Blankets. In our earlier generation forges, we included a liquid Rigidizer to harden the blanket and Satanite Refractory to seal the fibers and that worked out great. However, we felt that the forges we manufacture need to be many times safer for our customers.

Working with the Thermal Ceramics department at Morgan Advanced Materials in late 2021, we made the decision to switch over to the new Superwool XTRA insulation blanket. The blanket is both a Low Bio-Persistent and does not form crystalline silica when heated up. It is not classified as hazardous or carcinogen. Morgan has been internally testing this product for 4 years with proven success. **We are the first forge manufacturer in the world to use the Superwool XTRA insulation blanket.** It is much more expensive but well worth the safety benefits! We are also still including the Rigidizer and Satanite Refractory with our forges for our customers, to achieve that rock hard surface that they are used to. Superwool XTRA has very high heat resistance characteristics, the working temperature is 1450°C (2642°F) and max temperature is 1650°C (3002°F).

Mr Volcano® Hero 2 Double Burner - PREP/ASSEMBLY INSTRUCTIONS



CRITICAL: Using only one burner?

Remove the second burner from the forge. Failure to do so will result in the heat entering the unused burner and damaging the ball valve and hose components

THINGS YOU'LL NEED

Mr Volcano Hero Double Burner Forge Kit
Personal Protection Equipment
2 Spray Bottles
Paint Brush

① Apply Rigidizer

Personal Protection Equipment must be worn to handle Rigidizer, Ceramic blanket and Refractory. (See Page 1). You will need two spray bottles: One for regular water, and one for rigidizer solution.

1. Unroll the insulation blanket and place it flat on a clean surface.
2. Mix the 16oz Rigidizer Concentrate with water using a 1 to 1 ratio, shake vigorously for 45 seconds before using.
3. Pre-wet the insulation: Spray water lightly on all sides of the blankets. This is done to prepare the blanket for the process of applying the rigidizer.
 - Tip: Using a hose on the "Mist" setting works even better, make sure to not soak the blanket up too much. Goal is to get the surface lightly wet.
4. Spray the Rigidizer on all sides of the blanket. Make sure the entire blanket is red. Use all 32oz.
5. Install the blanket into the Hero forge while the blanket is still wet. Make sure the entry tube hole isn't obstructed by the blanket to not get in the way of the flame.

There are two methods of drying the Rigidizer: Air drying or firing up the forge.

- A) **Air drying** - Air drying is recommended. This could take 24-48 hours. A cooling or heat fan will speed up the process.
- B) **Fired up drying** - Fire up the forge on low pressure (See Operating Instructions on Page 5) for 30-60 seconds. Then let it cool down. Do this several times to allow the process to remove water from the blanket. This will generate some steam in this step. **Sputtering of the burner during this step is normal, as the environment inside the forge is high in humidity.**

Do not proceed until the blanket is dry and rigid. Trapped water, when heated, will cause a burst through the refractory layer. The red color in the rigidizer is not an indicator of the blanket being dry. It could retain the color after being dried out.

② Apply Refractory

Included is 4 pounds of Satanite® Refractory. 8x baggies total. For the first layer, combine 4.5x of the 8oz baggies (Totaling 2.25 pounds). For the second layer, use 2.5x of the 8oz baggies (amounting to 1.25 pounds). The last remaining 8 oz bag of refractory is for future maintenance. To achieve the desired thickness, you will need to apply two coats of Refractory. The idea is to apply two thin layers. When preparing to mix the Satanite refractory, make sure to measure both with a scale – do not guess. Mix for 5 minutes. Look for a sour cream type consistency. See below for mixing ratios. **NOTE:** Refractory curing must be done in **at least a 50 F** environment - the warmer the better.

1. **Pre-wet the insulation:** Spray water lightly on all exposed areas of the insulation. Any dry spots in the blanket will absorb the water from the refractory mixture too fast and cause cracks. Too much water will prolong the drying step
2. **Apply 1st Coat:** Mix the following: **2.25 lb Satanite Refractory + 9.94 fl oz water** (10.37 oz in weight). See "Applying" below)
3. **Allow the 1st Coat to dry:** Let the first coat air dry for 24 hours. If after 24 hours some areas are still wet, you can dry it with a heat gun, hair dryer, or let it air dry for another day.
4. **Apply 2nd Coat:** Mix the following: **1.25 lb Satanite Refractory + 5.53 fl oz water** (5.77 oz in weight).
5. **Allow the 2nd Coat to dry:** Same way as the first coat.
6. **Cure the layers:** See curing below.

Applying:

1. Apply the mixture using a brush to cover all exposed surfaces of the blanket.
2. Do not get refractory into the entry tubes. Wipe off refractory from the entry tube or outside shell while it is still wet.

Cure the refractory coatings:

After the second layer has been dried, you are now ready to cure the refractory to make it a one solid piece. The idea is to remove water that is still left in the refractory coating after the drying. It is very important to do this slowly, by heating it up in the given time increments and letting it cool down. As soon as you see steam forming then turn it off. Don't rush this process.

- A. Start with firing up the forge burners on low and keep it on for 45 seconds. (See Operating Instructions on Page 5)
- B. Turn off the forge and allow it to cool down for 5 minutes.
- C. Repeat Step A and B – and each time changing step "A" by adding 5 seconds to each interval. (45 seconds, then 50 seconds, 55, 60, etc.) The goal is to get to a point where you don't see any steam forming.

During the curing process: Most water escapes through the cold face, not the hot face. The seams of the forge serve as weep holes to the cold face of the forge to promote steam to exhaust during the curing heat up process. It is normal for refractory to develop some cracks after final drying and regular use.

③ Hose and Burner

Hose Assembly: Using the hose clamp, tighten the hose onto the Regulator. Next, connect the Y-splitter to the 6' hose and hose ends, make sure to follow the diagram of the Y-splitter position.

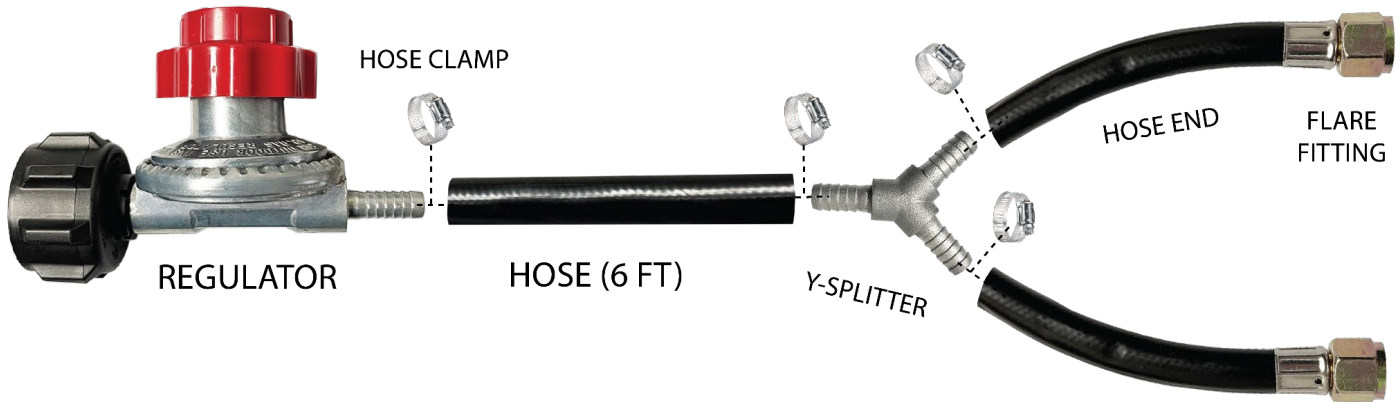

Burner Installation: The forge comes with two types of burners; a Primary Burner and the Back Burner. When using only the Primary Burner, remove the Back Burner from the forge and close the ball valve.

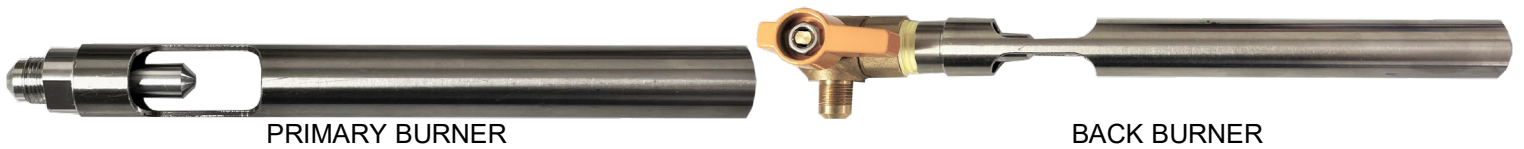

1. Slide the air chokes onto each burner tube.
2. Lower the burners down the forge entry tube. Each burner should sit about 3/4" higher than the bottom of the entry tube. (See diagram below) Tighten the thumbscrews on the forge entry tubes to secure the burners in place.
3. Make sure the ball valve is closed shut and the regulator turned off.
4. Connect the hose; flare fittings to the burners and the regulator end to the propane source.
4. Insert the fire brick. (This is only after curing the Rigidizer and Refractory)

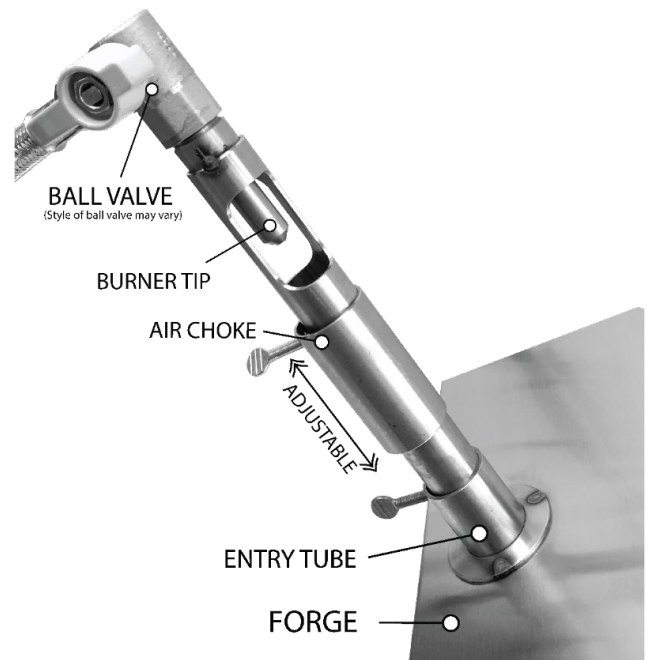
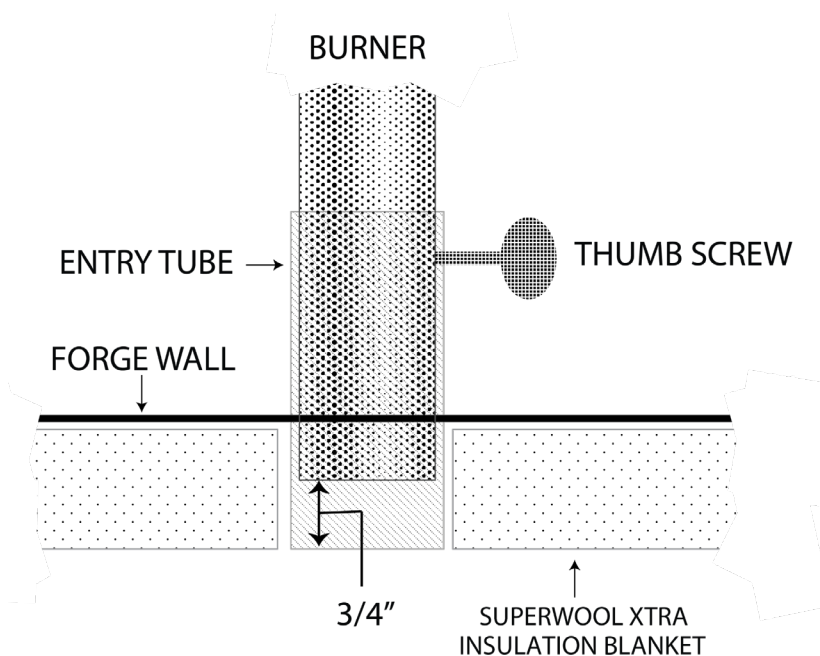

OPERATING INSTRUCTIONS

STARTING THE FORGE

- 1** With soapy water check for leaks: the regulator connections and under the turn knob, hose connection, and flare fitting.
- 2** Make sure the choke is not obstructing the burner's air intake openings. Make sure the regulator is turned off, all the way to the left (counterclockwise).
- 3** Light a long match or a flammable material (i.e., bbq fire starter, cardboard, paper) and set it inside the forge under the burner tube opening
- 4** Open the valve in the propane tank slowly to fully open. Then open up the regulator by turning it clockwise. The burner should fire up at this point. Adjust the regulator and the choke to achieve the desired flame. You're looking for a blue flame.

CRITICAL – MUST READ:

- ❖ **When running the forge with just one burner:** Always remove the second burner from the forge. Failure to do so **will** result in the heat entering the unused burner and damaging the ball valve and hose components.
- ❖ **If the burner does not light up and you do not see a flame:** Immediately turn off the gas and wait for a few minutes for the gas to dissipate before attempting to light again.
- ❖ **Watch for blockages in the entry tube** – Even a small amount of refractory or ceramic blanket will throw off the flame and run too rich or too lean. A blockage can also cause the base of the burner on the outside to glow red hot, if you see this, turn the forge off, wait until it cools down, and clean the entry tube of ANY blockages.
- ❖ Propane expands 7x during combustion and must be vented. Completely closing both ends of the forge will quench the flame. A small opening will trap gasses and reduce the efficiency of the burners. Allow for an adequate opening.
- ❖ **After shutting down the forge:** Raise the chokes up to close the burner openings and remove any obstructions from the ends of the forge, to allow the heat to dissipate through the sides and not go up the burners and cause damage to the hose.

TIPS / SAFETY MEASURES

- Use this forge with propane fuel only. Do not forge galvanized steel - it creates toxic fumes that can cause death.
- Cracking of the sultanite refractory is normal. The new and improved Superwool Xtra blanket is no longer a health concern if some of the ceramic blanket is exposed. The main purpose of the sultanite coating is to: create a hard forge interior, provide some resistance to flux like borax and all around makes the forge more durable.
- Do not leave forge unattended. Put the propane tank as far as the hose will let you.
- Never light the flame from the air intake part of the burner, always light from inside of the forge.
- Keep your eyes, hands, and any flammable material far away from the flame to not inflict any damage or injury.
- Make sure the propane hose is away from the opening of the forge to not be damaged by the flame.
- Keep an eye out for a potential tipping hazard, especially when the forge is running. Take care not to bump into it or have anything pulling down on the hose.
- You can use the burner choke to partially close off the burner openings, to run the forge 'lean' to reduce scale on your workpiece, which is the result of oxidation.

TROUBLESHOOTING

My flame is sputtering..

- ❖ Allow for the forge to heat up. When the forge isn't heated up it's normal for it to sputter.
- ❖ Check for crosswind, if you are working outside, cold air or wind could cause the flame to sputter. Use a firebrick to block one end of the forge.
- ❖ Check the burner nozzle, burner tube and entry tube for blockage, look for refractory or insulation blanket being the source of the blockage. Clean the burner nozzle tip (where the propane comes out of) with a welding wire to make sure there is no blockage there either.
- ❖ Make sure the tank is full and not low on pressure, a tank that is low and nearing empty will cause sputtering.
- ❖ Make sure the burner is recessed $\frac{3}{4}$ " inch into the inlet tube of the forge. The burner should not be protruding through the inlet tube or even flush with the inlet tube.
- ❖ If there is no firebrick inside the forge, put one inside to create a smaller area for combustion.
- ❖ Make sure the regulator is not in "safe mode". To reset the regulator: With the tank regulator fully open, turn the red knob on the regulator on the hose assembly all the way to off (counterclockwise). Wait a few seconds then slowly turn the regulator in the clockwise direction turning the propane flow back on.
- ❖ Lower the chokes to allow more air intake.

My regulator or tank keeps freezing resulting in low pressure.

- ❖ While this is normal after operating the forge for an extended period of time, some things could be done to mitigate this. Start by turning the valve and unhooking the regulator and hose. Wait for 10 minutes and then attach it all again. When firing the forge up again, make sure you do so by slowly opening the hose regulator. This can also occur when liquid propane enters the regulator caused by the tank being overfilled or is not standing upright. Most often, this happens when the propane is leaving the tank faster than it is designed for, a simple solution is simply getting a larger tank. A 100lb tank is the tank of choice for enthusiasts. Some users have also reported putting their propane tank in water to keep it from freezing.

HAVE QUESTIONS? CONTACT US SUPPORT@MRVOLCANO.COM