

WARNING

Mr Volcano® Hero forge reaches temperatures of up to **2600°F** and requires the best safety practices. To ensure safe and proper procedures, read this safety and instruction manual in its entirety before using the forge.

SECTION 1: PRODUCT SAFETY

EYE PROTECTION



HAND PROTECTION



RESPIRATORY



PERSONAL PROTECTION EQUIPMENT

PPE is required when handling the Rigidizer, Satanite Refractory, and Insulation Blanket during installation.

INSULATION BLANKET:

This forge comes with **Superwool XTRA LBP** insulation blanket. See Section 4 for all the benefits of this insulation blanket. However, we still encourage and recommend our customers to wear gloves and respirator when handling the insulation blanket.

RIGIDIZER: Do not drink. Avoid contact with skin or clothes. Will mildly dry skin and harden clothes.

SATANITE REFRACTORY: Avoid breathing in. Gloves and a N95 or better mask are required

SECTION 2: OPERATIONAL SAFETY

USE THIS FORGE WITH PROPANE FUEL ONLY

BURN / FLAME HAZARD

- Before firing the forge, remove any potential tipping hazards. Check that the propane hose is not in walks way and in anyway could be pulled down.
- Keep the propane hose away from the flame and put the propane tank as far as the hose will let you.
- Wear hand, face, eye protection and nonflammable clothe.
- Keep your eyes, hands, and any flammable material away from the flame to not inflict any damage or injury.
- Do not touch any part of the forge while it is heating up or hot, the **surface** temperature of the forge and components will reach up to **600°F**. Allow for the forge to fully cool down before handling.
- Never light the flame from the air intake part of the burner, always light from inside of the forge.
- Do not leave forge unattended.

FUME HAZARD

- Only use the forge in a well-ventilated area or outdoors.
- **Do not inhale any fumes produced by the forge.**
- Do not put galvanized steel - it creates toxic fumes that can cause death.
- Burning of propane produces carbon dioxide. Carbon dioxide can be fatal when an excess amount is inhaled.

SECTION 3: DISCLAIMER

The various uses of this product are outside our control; we can assume no liability for damages incurred through use or misuse of this product. Failure to follow instructions and generally acceptable practices may result in **personal injury or death and damage to property**. Follow the local laws, regulations, and codes in your place of business or home.

SECTION 4: SUPERWOOL XTRA

GOOD NEWS!

This forge comes with the **Superwool[®] XTRA** insulation!
A **major generational leap** in the thermal blanket insulation industry.
Mr Volcano is the first and only manufacturer of consumer forges and foundries to include this technology!
It emits **ZERO** crystalline silica, and the fibers are **Low Bio-Persistent**.

Containing high heat safely has been a task put forth before scientists, chemists and engineers for many decades. The existing material used, Refractory Ceramic Fiber (RCF) Blanket, made from Kaolin, came with negative health concerns. RCF, when heated above 1800°F, releases crystalline silica which are hazardous to our respiratory system. The second health concern was the airborne fibers. RCF fibers are not low bio-persistent, meaning they stay in the body for a long period of time, which could lead to health issues.

When forging, temperatures can reach well above 1800°F, and forge manufacturers would line their foundries with the RCF Blanket and rely on hardeners and refractory to contain the fibers and minimize exposure to the crystalline silica. However, we felt that the forges and foundries we manufacture need to be many times safer and take advantage of the latest technology.

Working with the Thermal Ceramics department at Morgan Advanced Materials in late 2021, we made the decision to switch over to the new Superwool XTRA insulation blanket. The blanket is both a Low Bio-Persistent and does not form crystalline silica when heated up. It is not classified as hazardous or carcinogen. Morgan has been internally testing this product for 4 years with proven success. The insulation has very high heat resistance characteristics, the working temperature is 1450°C (2642°F) and max temperature is 1650°C (3002°F).

We are the first consumer forge and foundry manufacturer in the world to use the Superwool XTRA insulation blanket. It is much more expensive but well worth the safety benefits! We are still including the Rigidizer and Satanite Refractory with our forges and foundries for our customers to achieve the rock-hard surface they are used to.

Mr Volcano Hero 2 - PREP/ASSEMBLY INSTRUCTIONS

SECTION 5: STEP 1 – APPLYING RIGIDIZER

Personal Protection Equipment must be worn to handle Rigidizer, Insulation Blanket and Refractory. (See Section 1). You will need a paint brush and two spray bottles: One to spray regular water, and one to spray the Rigidizer solution.

1. Unroll the insulation blanket and place it flat on a clean surface.
2. Mix the 16 oz Rigidizer Concentrate with water using a 1 to 1 ratio, shake vigorously for 45 seconds before using.
3. Pre-wet the insulation: Spray water lightly on all sides of the blankets, do not soak, just enough to get the surface lightly wet.
Tip: Using a hose on the “Mist” setting works great.
4. Spray the Rigidizer mix on all sides of the blanket. Make sure the entire blanket is red. Use all 32 oz.
5. While the blanket is still wet, install the insulation into the Hero Forge. Make sure the burner entry tube is not obstructed by the blanket so that it does not get in the way of the flame.

There are two methods of drying the Rigidizer: Air drying or firing up the forge.

- A. **Air drying** - This could take 24-48 hours. A cooling or a heat fan will speed up the process.
- B. **Fired up drying** - Fire up the forge (Operating Instructions in Section 9) on low pressure for 30-60 seconds. Then let it cool down. Do this several times to remove water and moisture from the blanket. This will generate some steam in the process. **Sputtering of the burner during this step is normal, as the environment inside the forge humid.**

Do not proceed until the blanket is dry and rigid. Trapped water, when heated, will cause a burst through the refractory layer. The red color in the Rigidizer is not an indicator of the blanket being dry. It could retain some color after being dried out.

SECTION 6: STEP 2 – APPLYING REFRACTORY

Included is 4 pounds of Satanite® Refractory Mortar. 8x baggies total.

For the first layer, combine 4.5x of the 8oz baggies (2.25 pounds).

For the second layer, use 2.5x of the 8oz baggies (1.25 pounds). The last 8 oz bag of refractory is for future maintenance.

To achieve the desired thickness, you will need to apply two thin coats of Refractory.

When preparing to mix the Satanite refractory, make sure to measure with a scale – do not guess. Mix for 5 minutes. Look for a sour cream type consistency. See below for mixing ratios.

NOTE: Refractory curing must be done in a temperature environment of **at least 50°F**- the warmer the better.

APPLYING TIPS:

- Using a brush will greatly help with spreading the mixture evenly.
- Do not get refractory into the entry tube. Wipe off refractory from the entry tube or the outside shell body while it is still wet.

STEPS:

1. **Pre-wet the insulation:** Spray water lightly on all exposed areas of the insulation. Any dry spots in the blanket will absorb the water from the refractory mixture too fast and cause cracks. Too much water will prolong the drying step.
2. **Apply 1st Coat:** Mix the following: **2.25 lb** Satanite Refractory with **9.94 fl oz** water (10.37 oz in weight). Cover all exposed surfaces of the blanket evenly.
3. **Allow the 1st Coat to dry:** Let the first coat air dry for 24 hours. If after 24 hours some areas are still wet, you can dry it with a heat gun, hair dryer, or let it air dry for another 24-48 hours.
4. **Apply 2nd Coat:** Mix the following: **1.25 lb** Satanite Refractory with **5.53 fl oz** water (5.77 oz in weight).
5. **Allow the 2nd Coat to dry:** Same way as the first coat.
6. **Cure the refractory coatings:** After the second layer has been dried, you are now ready to cure the refractory to make it a one solid piece. The idea is to remove water that is still left in the refractory coating after the drying. It is very important to do this slowly, by heating it up in the given time increments and letting it cool down. As soon as you see steam forming then turn it off. Don't rush this process.
 - a) Start with firing up the burners on low and keep it on for 45 seconds. (See Operating Instructions in Section 9)
 - b) Turn off the forge and allow it to cool down for 5 minutes.
 - c) Repeat Steps A and B – increasing the time in step "A" by 5 seconds to each interval until you don't see any steam forming.

During the curing process: Most water escapes through the cold face, not the hot face. The seams of the forge serve as weep holes to the cold face to provide an escape path for steam to exhaust during the heating of the curing process.

It is normal for refractory to develop some cracks after final drying and regular use.

SECTION 7: STEP 3 – HOSE and BURNERS

Hose Assembly: Connect the propane hose to the regulator, Y-splitter, and burners using the hose clamps. Make sure to follow the diagram of the Y-splitter position.

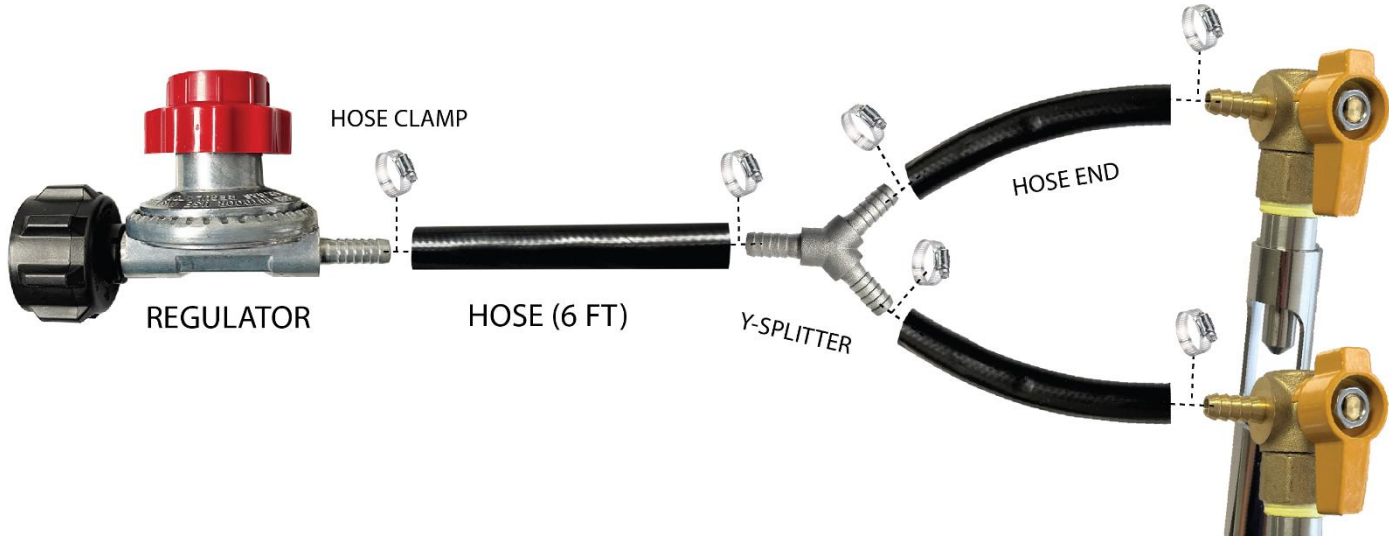

1. Slide the air chokes onto each burner tube.
2. Lower the burners down the forge entry tube. Position the burner 3/4" recessed from the inside of the foundry. (See diagram below)
3. Tighten the thumbscrews on the forge entry tubes to secure the burners in place.
5. Make sure the ball valves are closed shut and the regulator turned off.
6. Connect the hose; flare fittings to the burners and the regulator end to the propane source.
7. Insert the fire brick. (Only after curing the Rigidizer and Refractory)

CRITICAL: Using only one burner? Close the valve on the second burner and remove it from the forge.
Failure to do so will result in the heat entering the unused burner and damaging the ball valve and hose components

SECTION 8: DIAGRAMS

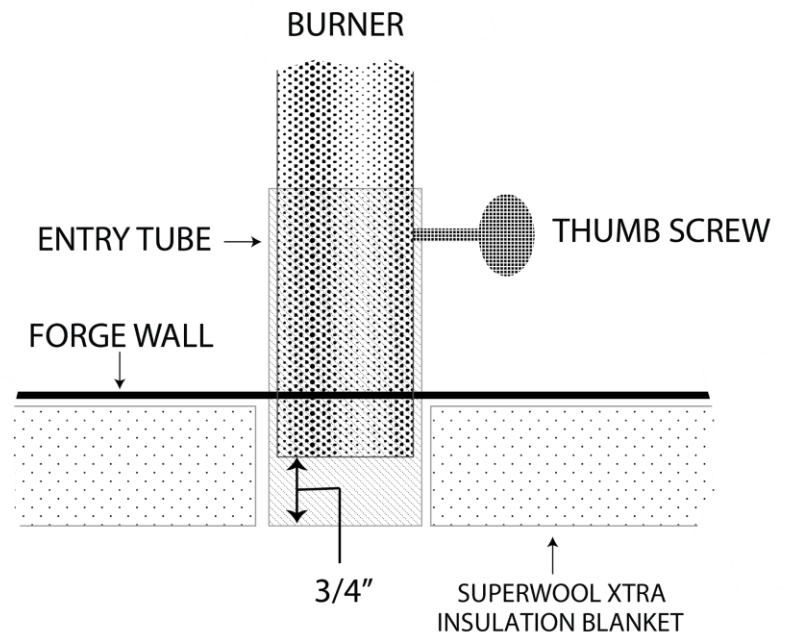
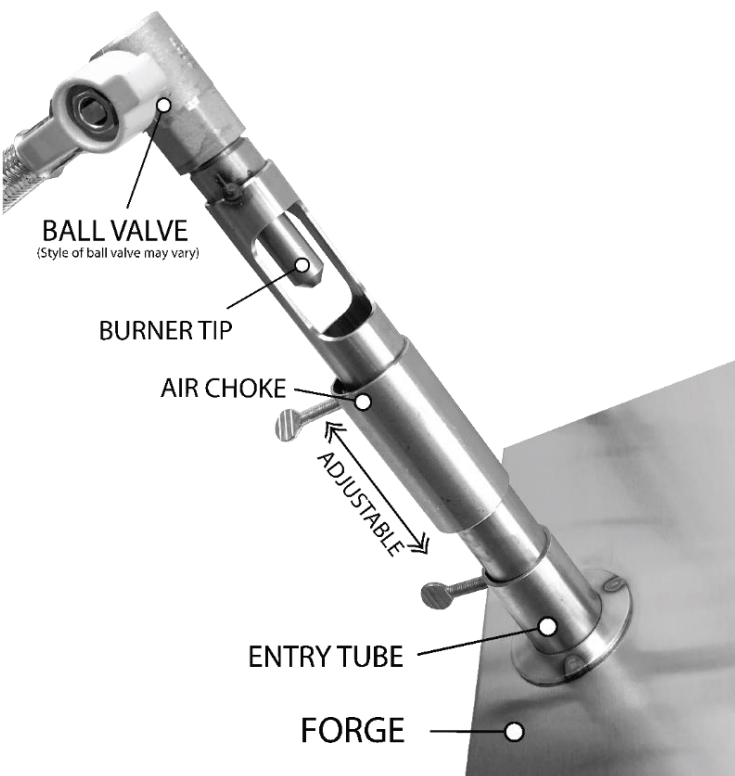

SECTION 9: OPERATING INSTRUCTIONS

STARTING

1. With soapy water check for leaks: the regulator connection and under the turn knob, hose connections, and flare fittings.
2. Open the burner's air intake by sliding the choke away from the opening.
3. Make sure the regulator is turned off, all the way to the left (counterclockwise).
4. Light a long match or a similar fire-starting method (i.e., bbq fire starter, lighting a piece of cardboard or paper) and set it inside the forge on the brick near the burner tube opening.
5. Open the propane tank valve slowly to fully open. Then open the regulator by turning it clockwise. The burner should fire up at this point. Adjust the regulator and the choke to achieve the desired flame. You're looking for a blue flame.

RUNNING

- **When running the forge with just one burner:** Always remove the second burner from the forge. Failure to do so **will** result in the heat entering the unused burner and damaging the ball valve and hose components.
- **If the burner does not light up and you do not see a flame:** Immediately turn off the gas and wait for few minutes for the gas to dissipate before attempting to light again
- **Watch for blockages in the flame entry tube** – Even a small amount of refractory or insulation blanket will throw the flame off and the burner will run too rich or too lean. A blockage can also cause the end of the burner to glow red hot, if you see this, turn the forge off, wait until it cools down, and clean the entry tube of ANY blockages.

SHUTTING DOWN

1. Turn the propane tank valve off then turn the hose regulator counterclockwise to turn it off.
2. Raise the chokes up to close the burner openings and remove any obstructions from the ends of the forge, to allow the heat to dissipate through the sides and not go up the burners and cause damage to the hose.

SECTION 10: TIPS

- Propane expands 7x during combustion and must be vented. Completely closing the top cover of the foundry will quench the flame. A small opening will trap gasses and reduce the efficiency of the burner. Allow for an adequate opening.
- Cracking of the Satanite Refractory is normal. The main purpose of the coating is to create a hard foundry interior, provide some resistance to flux like borax and all around makes the foundry more durable. Exposed blanket is no longer a problem as it is with forges that are lined with "Ceramic Insulation" which is a health hazard. This is only possible because this forge has the next generation Superwool XTRA insulation which eliminates the health hazard.
- To run the forge lean, use the air choke to partially close off the burner openings, this will reduce scale on your workpiece, which is the result of oxidation.

SECTION 11: TROUBLESHOOTING

My flame is sputtering.

- Allow for the forge to heat up. When the forge is not heated up, it is normal for it to sputter.
- Check for crosswind. If you are working outside, cold air or wind could cause the flame to sputter.
- Check the burner nozzle, burner tube, and entry tube for blockage, look for refractory or insulation blanket being the source of the blockage. Clean the burner nozzle tip, where the propane comes out, with a welding wire to make sure there is no blockage.
- Make sure the tank is full and not low on pressure, a tank that is low or near empty will cause sputtering.
- Make sure the burner is recessed $\frac{3}{4}$ " inch into the entry tube of the foundry. The burner should not be protruding through or flush with the insulation blanket.
- If there is no firebrick inside the forge, put one inside to create a smaller area for combustion.
- Make sure the regulator is not in "safe mode". To reset the regulator: With the tank valve fully open, turn the red knob on the regulator on the hose assembly off (counterclockwise). Wait a few seconds then slowly turn the regulator in the clockwise direction turning the propane flow back on.
- Lower the chokes to allow more air intake.

My regulator or tank keeps freezing resulting in low pressure.

- While this is normal after operating the forge for an extended period of time, some things could be done to mitigate this. Start by turning the valve and unhooking the regulator and hose. Wait for 10 minutes and then attach it all again. When firing the foundry up again, make sure you do so by slowly opening the hose regulator. This can also occur when liquid propane enters the regulator caused by the tank being overfilled or is not standing upright. Most often, this happens when the propane is leaving the tank faster than it is designed for, a simple solution is getting a larger tank. A 100lb tank is the tank of choice for enthusiasts. Some users put their propane tank in water to keep it from freezing

SECTION 12: PARTS LIST

NUMBER	DESCRIPTION	PART NUMBER	QUANTITY
1	Outer Shell – Stainless Steel – Hero 2	MVH2P1	1
2	Superwool XTRA Insulation Blanket	MVH2P2	1
3	Burner – Stainless Steel - Propane	MVP1A	2
4	Air Choke – w/ Thumbscrew	MVP4	2
5	Ball Valve	MVP3C	2
6	Rigidizer Concentrate 16oz	MVP7R16	1
7	Satanite Refractory 8oz	MVP5	8
8	High Heat Fire Brick	MVP6	2
9	Propane Hose – Complete Assembly	MVH2P3	1
9a	Regulator	MVH2P3A	
9b	Hose – 6 Feet	MVH2P3B	
9c	Y - Splitter	MVH2P3C	
9d	Hose Ends	MVH2P3E	

