



Theralux Active™ Heat Pro

Harness the warmth of nature.

Intelligent, energy efficient pool heating.

App control as standard, so you can control your heater anywhere.



 **theralux** | POOL WATER AT ITS BEST™

Using the warmth in the air, heat pumps are the most efficient way to heat your pool. The Heat Pro range is built with the highest-grade componentry, providing market leading reliability and performance.

Make the most out of your pool and enjoy warm water all year round.

Heat Pro uses inverter technology to save energy costs. As it reaches the desired temperature, the revolutionary variable speed compressor decreases consumption, cutting energy use by up to 30%.

WiFi-enabled, the range connects to your lifestyle. Use the Heat Pro app to monitor and control the heating from your smartphone or tablet.

Built to last from corrosion resistant aluminium, the innovative design takes up far less space than traditional pumps. Whisper quiet at less than 40 decibels, it's as discreet as a high-end dishwasher.



WiFi Enabled

Control and monitor your pools temperature from your smartphone or tablet



Set & Forget

Continually measures and maintains your desired pool temperature



Energy Efficient

Leading inverter technology providing energy savings of up to 30%



Easy Integration

Adapts to all existing pool and spa systems



Whisper Quiet

As inaudible as a high-end dishwasher



Heat and Cool

Suitable for all climates and seasons, with heat and cool temperature option



Thermalux Active™ Service Guarantee

- 3 years warranty for whole unit
- 10 years warranty for compressor
- Lifetime warranty for Titanium heat exchanger



Thermalux Active™ Lifetime Pool Care

Exclusive customer care and support for the life of your pool

App Control

Connect your pool to your lifestyle



Remote Control

Monitor and control water temperature anywhere



Status Report

Live monitoring of your heat pump status



Easy Back Up

Share heat pump with support technicians



Schedule

Change operating times on the run to suit your lifestyle



Heat Pump Installation and Clearance Information

The Heat Pro range of inverter heater pumps are compact and designed for outdoor use. The units can be placed indoors, but this will require consultation with Theralux or an Authorised Dealer.

Heat pumps are **not** to be placed in an enclosed area with limited air volume where units discharge will be re-circulated.

Heat pumps are **not** to be placed under or near shrubs which can block air flow to the inlet.

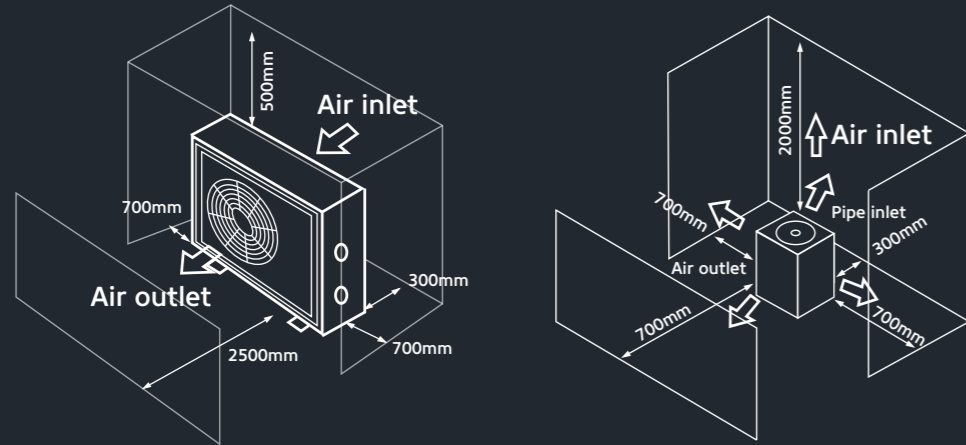

Model options

Product code	Size	Product code	Size	Product code	Size
THERAI6009	9.0KW	THERAI6020	20KW	THERAIV6217	17KW
THERAI6014	14KW	THERAI6025	25KW	THERAIV6230	30KW

Heat Pro 09i Dimensions (mm)

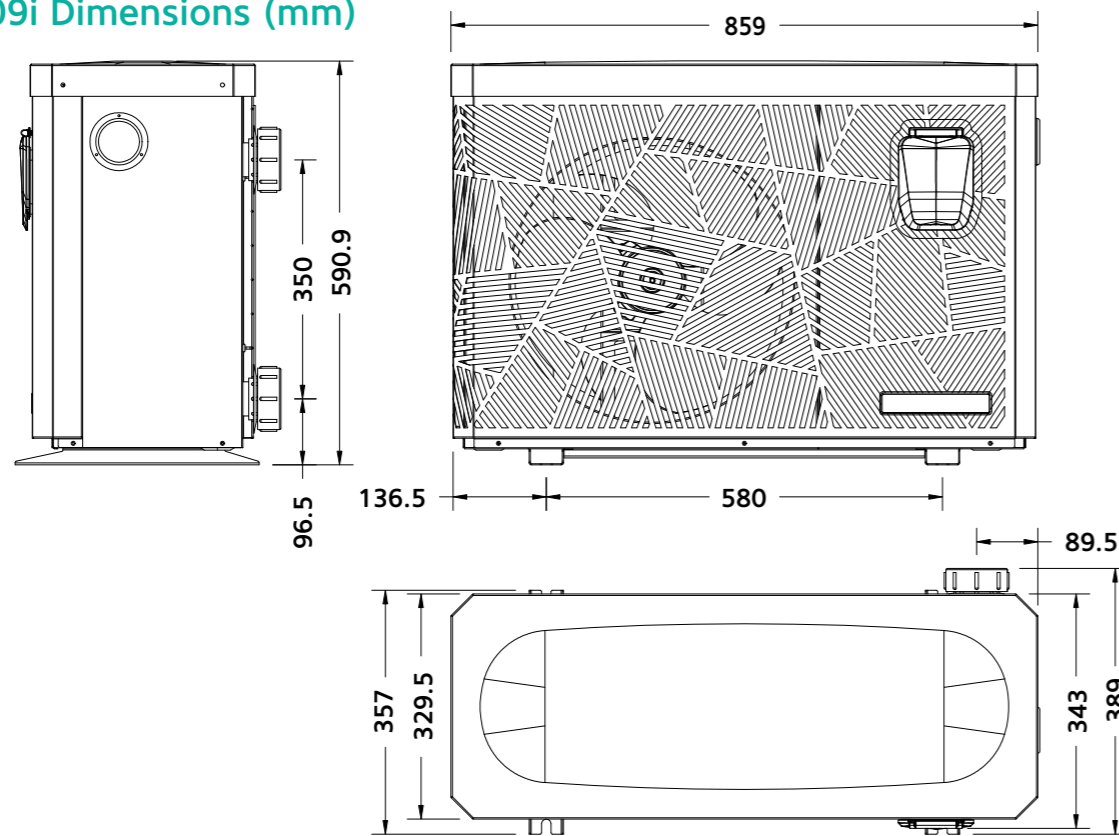

Heat Pro 14i Dimensions (mm)

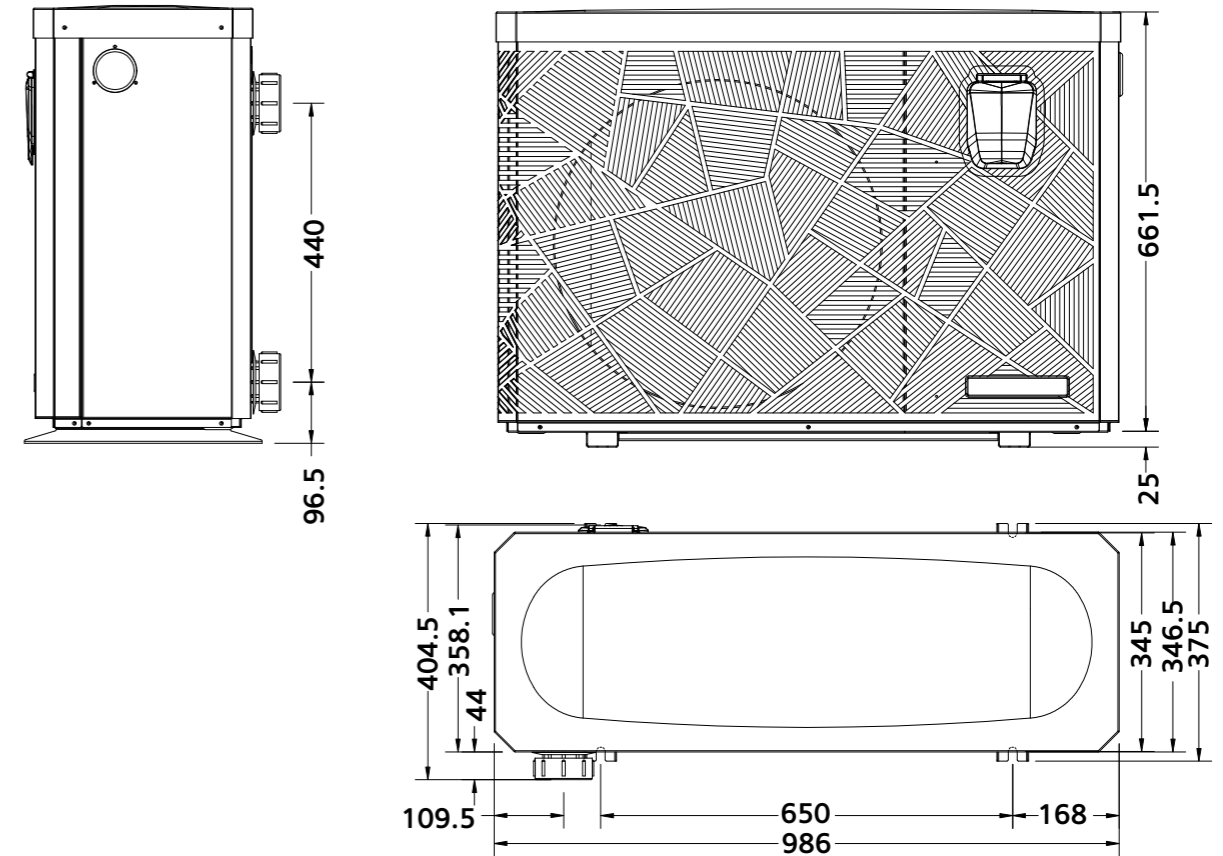

Heat Pro 17iv Dimensions (mm)

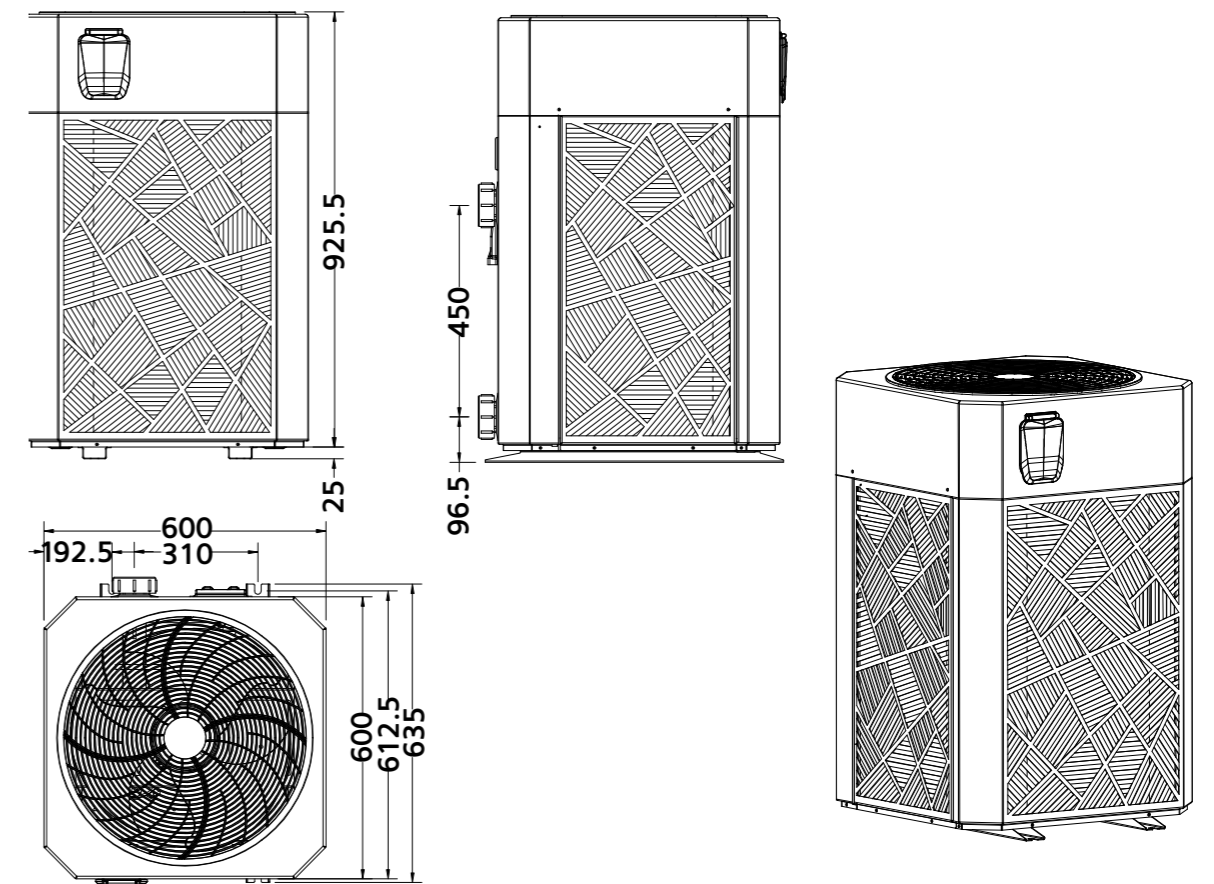

Heat Pro 20i / 25i Dimensions (mm)

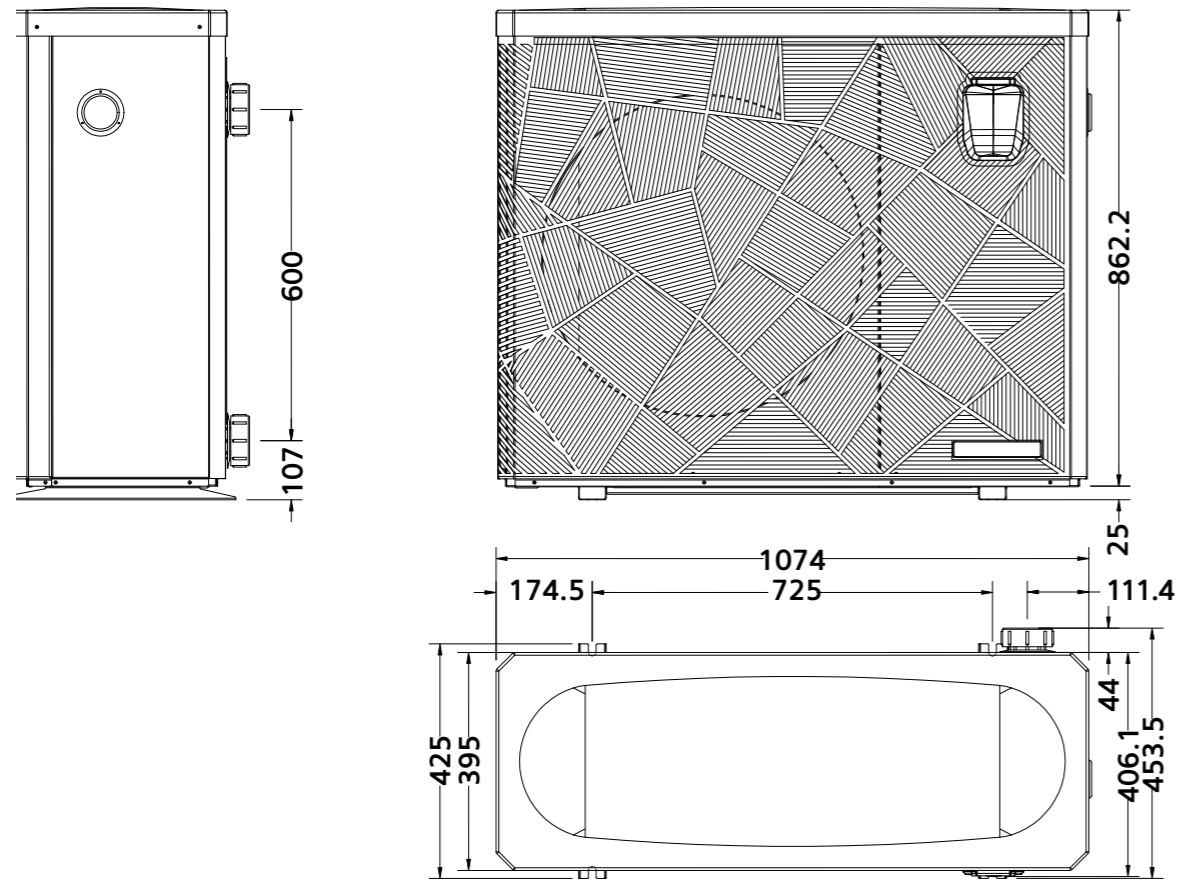

Heat Pro 30iv Dimensions (mm)

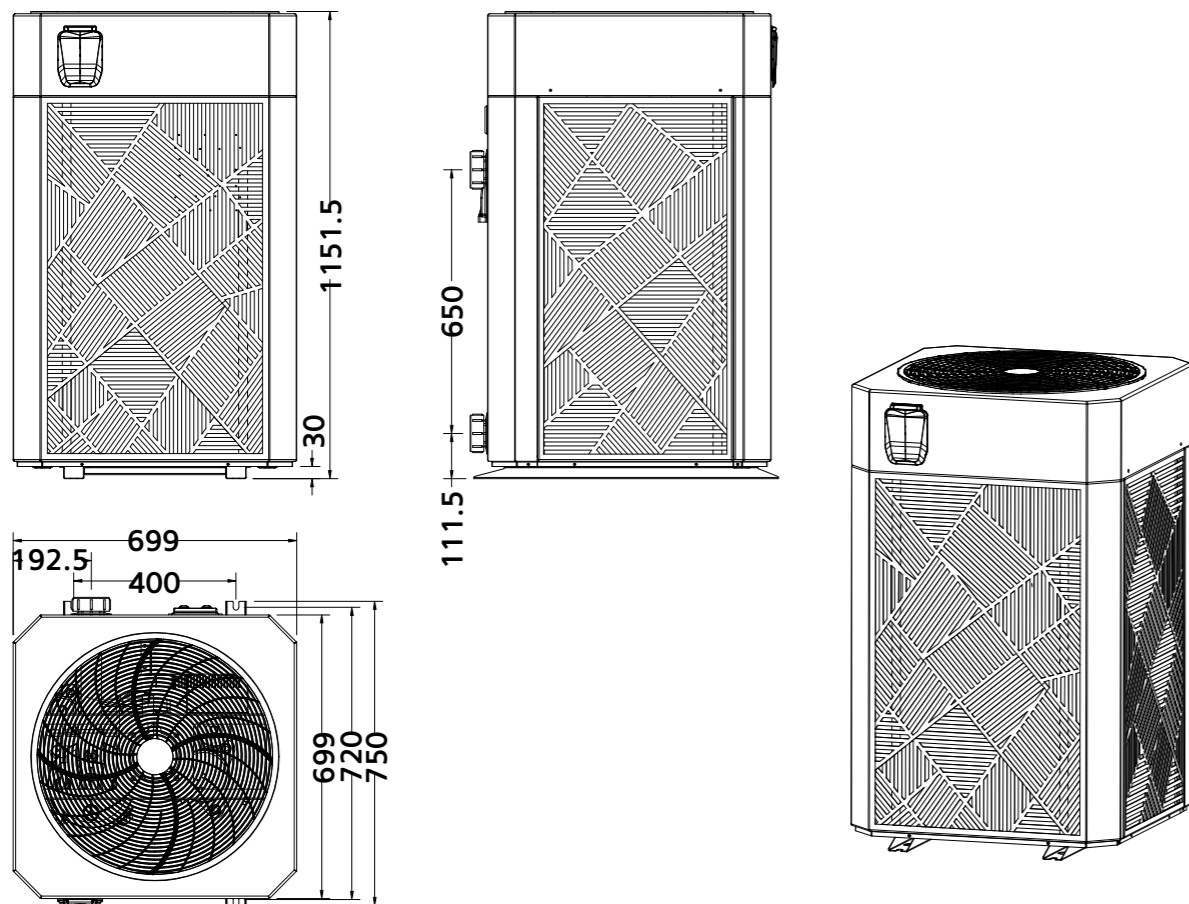

Performance at its best

Model		Heat Pro 09i	Heat Pro 14i	Heat Pro 17iv	Heat Pro 20i	Heat Pro 25i	Heat Pro 30iv
* Performance at Air 28C, Water 28C, Humidity 80%							
Heating capacity	kW	2.4 - 9.5	3.2 - 13.5	3.8 - 16.0	4.7 - 19	5.9 - 24	6.8 - 28.5
Power consumption	kW	0.15 - 1.51	0.2 - 2.26	0.23 - 2.67	0.29 - 3.1	0.37 - 4.0	0.43 - 4.75
C.O.P.		6.3 - 16	6.2 - 16	6 - 16	6 - 16	6 - 16	6 - 16
* Performance at Air 15C, Water 26C, Humidity 70%							
Heating capacity	kW	2.2 - 6.8	2.2 - 9.5	3 - 11.2	3.9 - 12.8	4.5 - 17.2	5.6 - 19.6
Power consumption	kW	0.28 - 1.45	0.31 - 2.07	0.42 - 2.43	0.54 - 2.78	0.63 - 3.74	0.78 - 4.26
C.O.P.		4.7 - 8	4.6 - 7.2	4.6 - 7.2	4.6 - 7.2	4.6 - 7.2	4.6 - 7.2
Compressor type		Inverter Compressor					
Voltage		220~240V / 50Hz or 60Hz /1PH					
Rated current	A	6.9	10	11.8	14	17.7	21
Minimum fuse	A	10	15	20	25	30	40
Advised water flow	lpm	49	67	77	84	134	167
Water pressure drop	Kpa	12	15	15	18	20	25
Heat exchanger		Twist-titanium tube in PVC					
Water connection		40mm					
Fan quantity		1					
Ventilation type		Horizontal	Horizontal	Vertical	Horizontal	Horizontal	Vertical
Fan speed		500-850	550-850	550-850	450-650	450-650	450-600
Power input of Fan	W	10-120					
Noise level(10m)	dB(A)	≤ 25	≤ 33	/	≤ 34	≤ 35	/
Noise level(1m)	dB(A)	32-46	40-54	41-54	41-54	42-60	42-60
Refrigerant		R410A					
Net weight	kg	70	80	98	119	125	130
Net dimension	mm	859x389x591	986x405x687	600x663x948	1074x454x888	1074x454x888	700x750x1152

More from Theralux

Combine your heating package with our other popular pool products.

Pool+ Manager

Your pool in the palm of your hand.

Manage and control your heating, existing equipment and chemical dosing in one app.



Quantum Purity

Powerful, environmentally sustainable and chemical-free pool water purifier.

Converting backyard swimming pools to naturally purified water, reducing the need for harsh chemicals.



Essential Earth Minerals

Water. Made Irresistible

Drawing on the active cleansing properties of natural minerals, our gentle, odour-free magnesium formula nourishes the skin.



Heat Demand Pro

Intelligent heating technology

The Heat Demand Pro fits into any pool system allowing the heat pump to run both within and outside the pool filtrations times.



A DIVISION OF  INTERNATIONAL QUADRATICS

Visit theralux.com.au or call
Australia 1300 131 788
New Zealand +64 9 527 0753

AVAILABLE FROM

