

Hydraulic Shearing Machine

Model: HQ11-6.5X1300



Operation Manual

Contents

I.	Structure and Use-----	3
II.	Main Technical parameter -----	3
III.	Swing and Installation -----	3
IV.	Test run and Preparation before test-----	4
V.	Adjustment of blade clearance-----	4
VI.	Lubrication-----	6
VII.	Function of Back Gauge -----	6
VIII.	Repair and Maintenance-----	7
IX.	Hydraulic part-----	8
X.	Electrical part-----	8
XI.	Drawing and Parts List-----	10

I .Structure and Use

The power of this shearing machine is hydraulic drive, transmit smooth. The major components such as Machine frame, upper knife frame, work table, etc. are all with welded-steel plate construction, make it with high strength of structure, nice appearance, compact, safety and reliable. With electric back gauge and digital feed, fast and accurate.

This machine is suitable for metal plate processing, electrical, automotive and sheet metal cutting process.

II .Main Technical parameter

Serial No.	Technical Parameter	value	Unit	Remarks
1	Max.shearing thickness	6.5	mm	$Q_b \leq 450 \text{N/mm}^2$
2	Max.shearing width	1300	mm	
3	Shearing angle	2.5	°	
4	Travel of top rest	80	mm	
5	No.of strokes of top rest	about20	Num./ Min.	
6	Height of work table	860	mm	
7	Max. Distance of back gauge	600	mm	
8	Motor power(kW)	5.5	Kw	
9	Packing size	215x175x165cm		

III.Swing and Installation

1.Moving: When moving , must ensure the machine keep balance and stable. should be moved by forklift or crane. Please pay attention to the following moving draw:

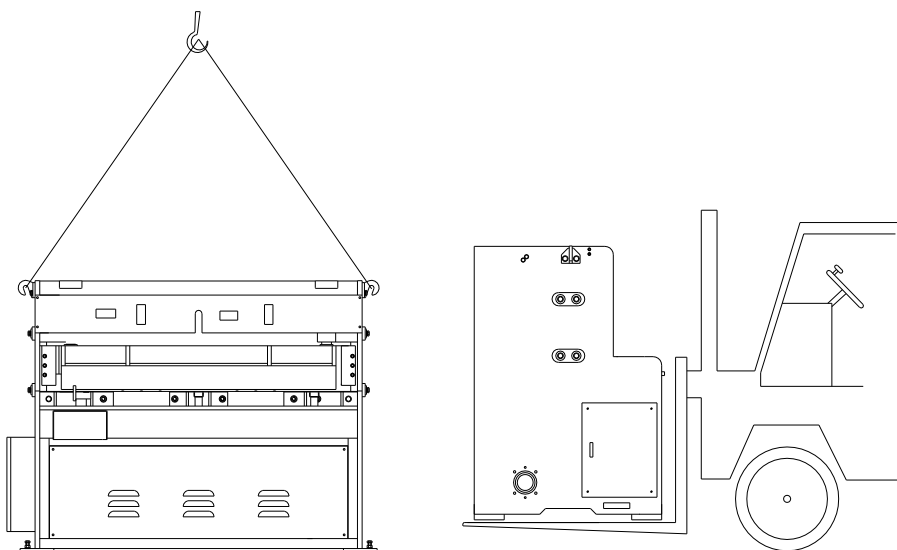

2. Installation: The machine should be installed on level bottom of foundation, and adjust work table to horizontal and vertical within 0.3mm/1000mm. Foundation drawing as below:

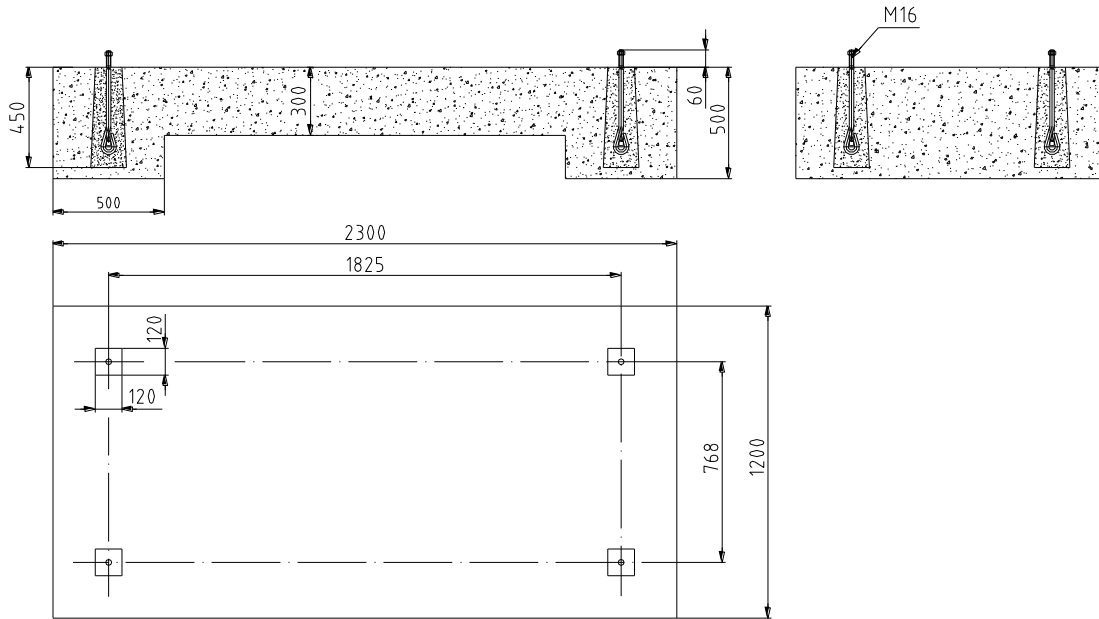

IV. Test run and Preparation before test

1. After installation, must clean the anti-rust oil and the dust on the machine away.
2. Check the screws, nuts, etc on each connection to make sure they are without looseness, the transmission part should be no obstruction
3. Inject clean hydraulic oil into the tank: summer (when ambient temperature is high) with 46 # hydraulic oil, winter (when ambient temperature is low) with 32 # hydraulic oil. Generally oil level position should be to the upper part of content gauge.
4. Check oil road whether smooth according to lubrication instructions, and inject lubricating oil.
5. Check the electrical components in electrical box to make sure they without any looseness, then plug in and connect earth wire, start the motor (pay attention to direction of rotation, reversal is prohibited!), Observe whether abnormal phenomena or not. And check whether system pressure need adjust (10Kpa, have been adjusted when leave factory), if not please adjust. Start motor for idle running.
6. Check whether the gap value between up blade and down blade is the same as cutting thickness
7. Cutting according to the operation manual.

V. Adjustment of blade clearance

The correspondence between plate thickness and shear blade clearance is as following draw:

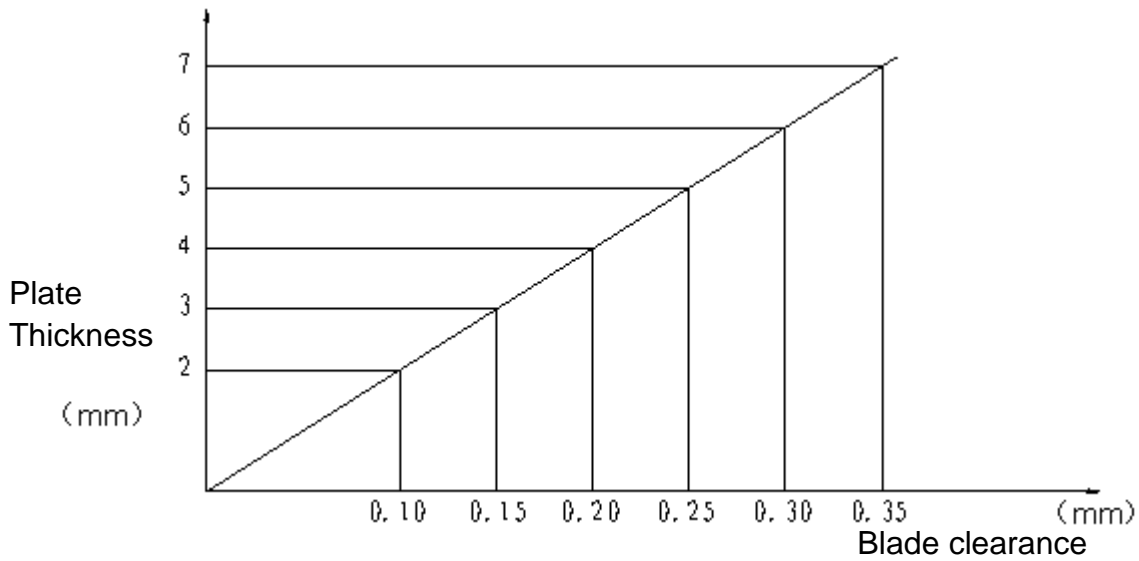

Method of adjustment: (As following drawing) make locknut #72、#26 a little looseness, then also the bolt #19. Loose bolts #70, fasten bolt #27, the blade gap value increases; Loose bolts #27, fasten bolt #70, the blade gap value reduction. Check blade gap value with feeler gauge, lock nut #72, #26, locking bolt #19 when gap value is conform to cut thickness. At the same time loose or fasten nut #71 (direction bolt #70 is the same), which with function of assist adjustment.

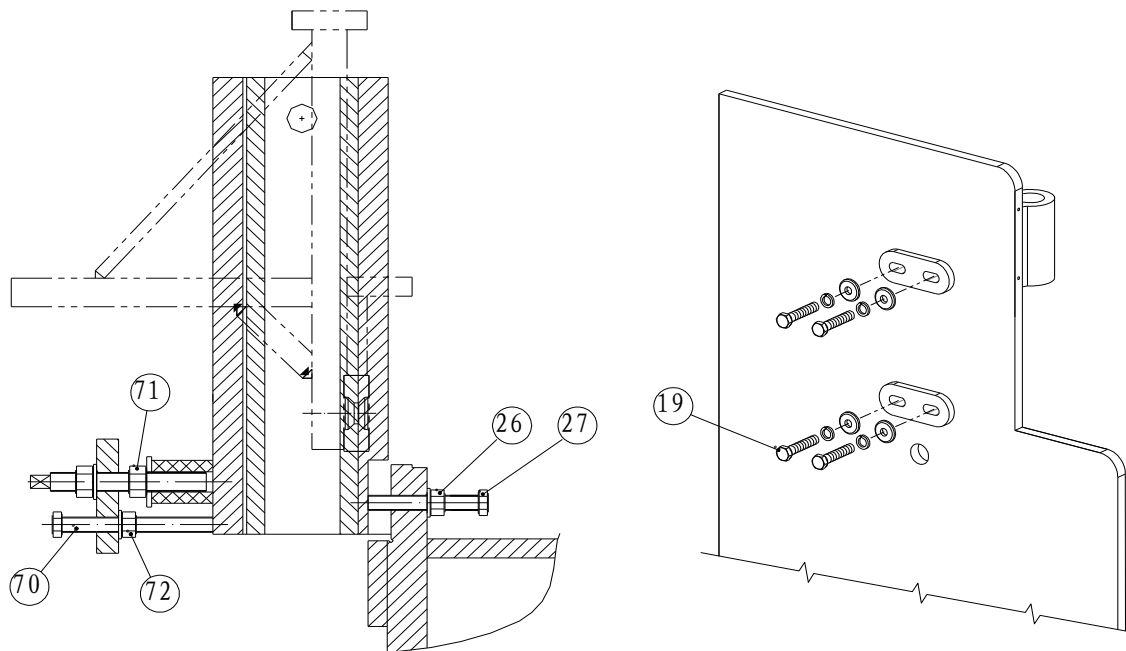

VI. Lubrication

Serial No.	Lubrication position	number of lubrication	Time of lubrication	Type of lubricants
1	Upper parts of Top rest	2	1/ per shift	Machine oil
2	Axis pin of top rest	2	1/per shift	Machine oil
3	Copper sleeve of principal axis	2	1/per shift	Machine oil
4	Axis pin of connecting rod	2	1/per shift	Machine oil
5	End of hydraulic cylinder	2	1/per shift	Machine oil

The machine adopt manual lubrication pump, lubrication of concentration and shunt.

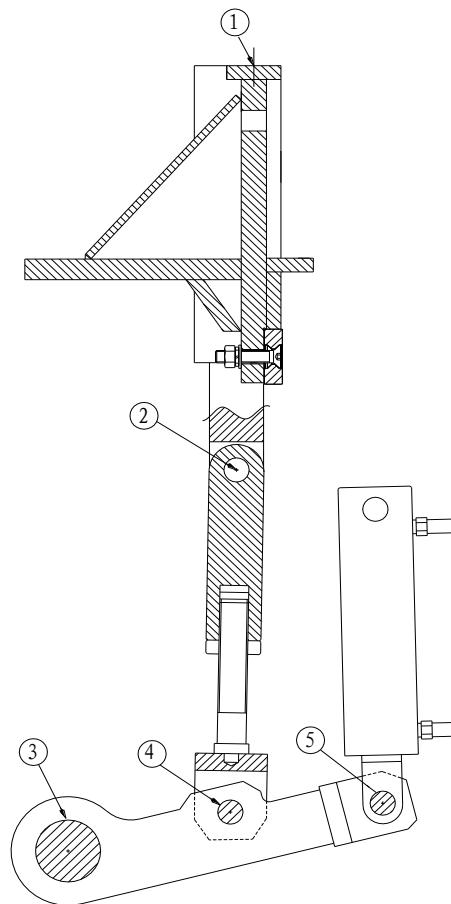

VII. Function of Back Gauge

The machine is with electric back gauge, and with manual regulatory function, when adjust by manual, push the hand wheel to position A, then rotate hand wheel to adjust.

When adjust by electric, pull hand wheel to position B, to avoid the hand-wheel rotating.

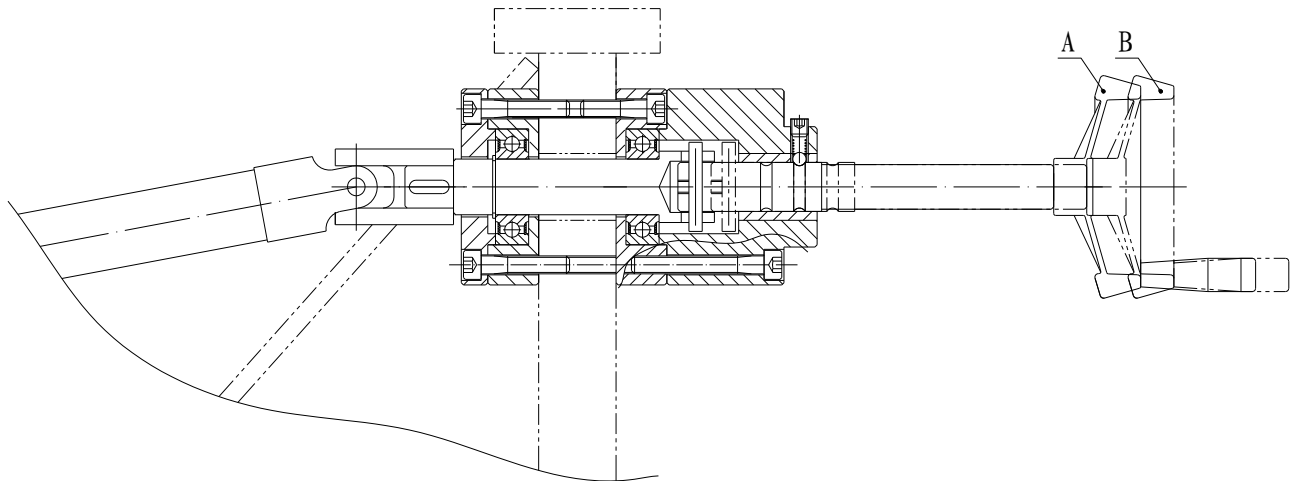

VIII. Repair and Maintenance

- 1、 The machine must be operated by specially-assigned person, should read the instruction manual carefully before operation.
- 2、 The machine must be kept clean, the parts without painted and sliding parts should be coated with grease, should be coated with anti-rust oil if don't use for a long time.
- 3、 Cutting blade should be kept sharp, if damaged and wear down should be sharpen or replace timely; should avoid cutting material with exceed thickness, or with hard scars, slag, welding line, etc defects such as edges or exorbitant hardness material.
- 4、 Should use clean and non-corrosive grease.
- 5、 Operate according to rules, do not overload the machine in order to avoid damage machine parts.
- 6、 While working, whether what anomalous thing happend, should stop operation immediately, poweroff, and inform relevant department to check.
- 7、 Poweroff when finished work, and clean up the machine.
- 8、 Should check circuit regularly, pay attention to motor's rotary direction when examine and repair motor or re-connected circuit after break.

Note: The first installation, it is necessary to keep the oil level in tank, should mend oil appropriately after one work cycle, oil level is too low or idling without oil is prohibited. Replace new oil after 100 hours from add hydraulic oil at first time, after can replace new oil each year (about 1500 working hours).

IX. Hydraulic part

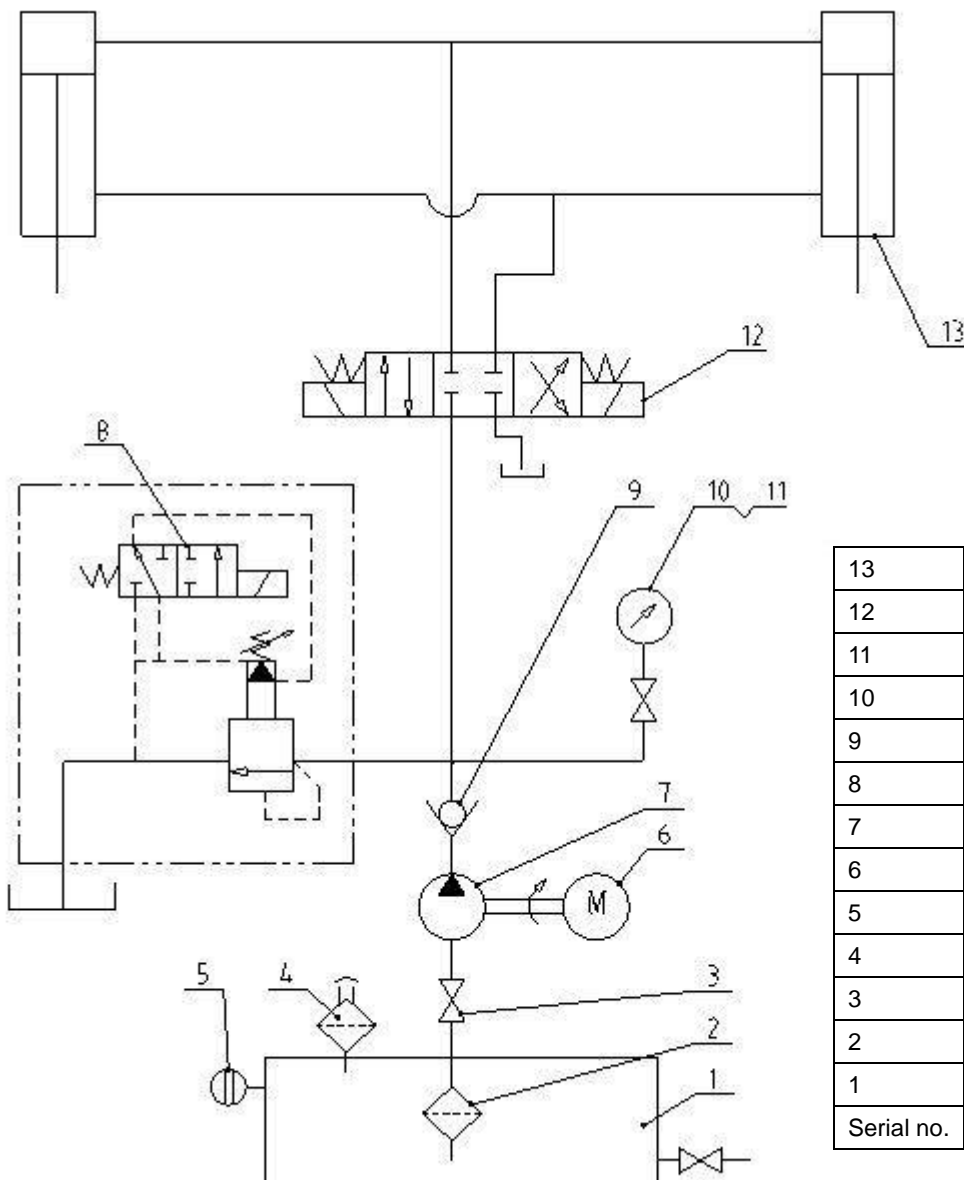

13	Oil cylinder	2
12	Magnetic exchange valve	1
11	Switch for pressure gage	1
10	Pressure gage	1
9	Check valve	1
8	Magnetic relief valve	1
7	Vane pump	
6	Motor	1
5	Liquid indicator	1
4	Air filter	1
3	Ball valve	1
2	Oil absorption filter	1
1	Oil tank	1
Serial no.	name	Qty

X. Electrical part

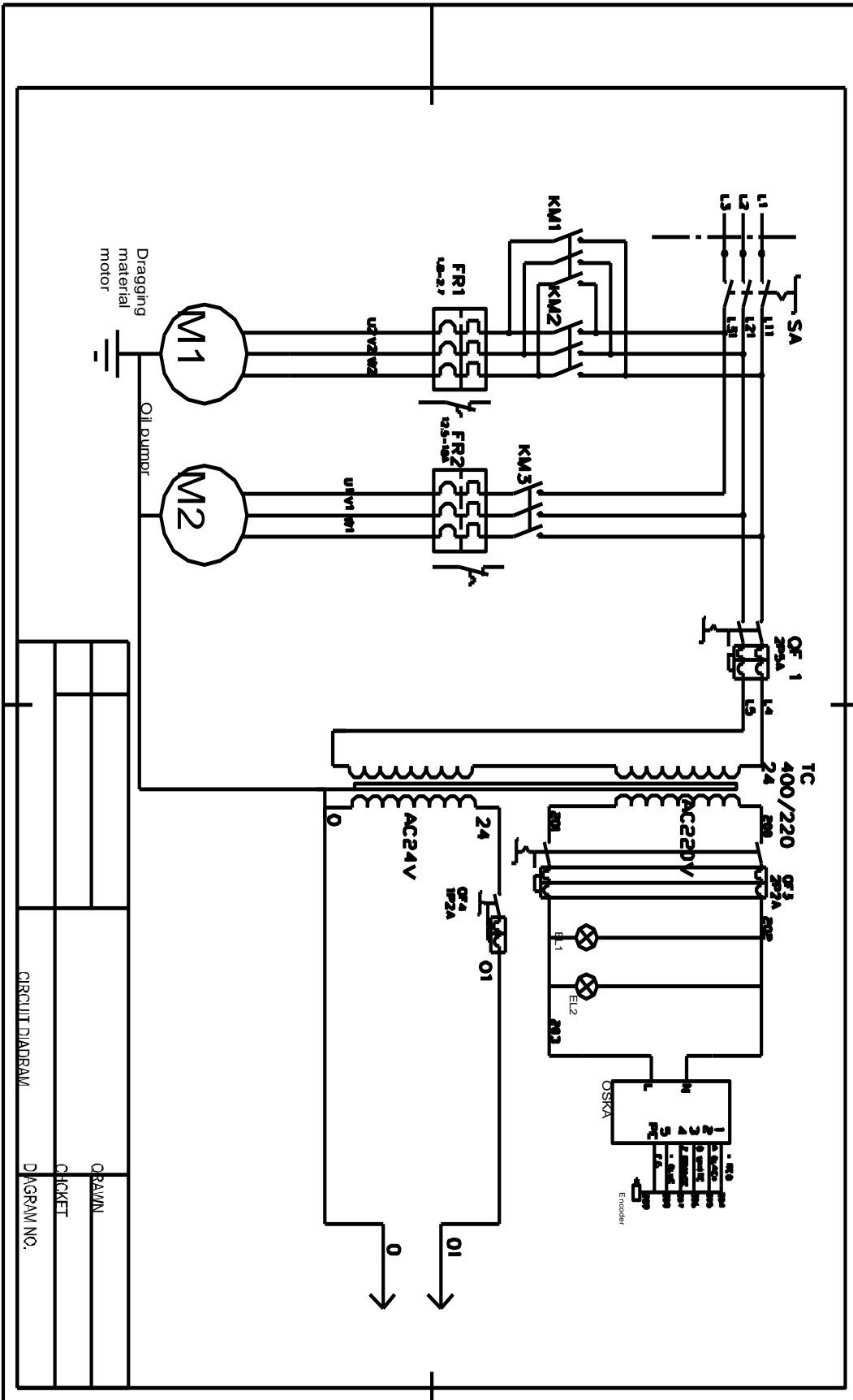

CIRCUIT DIAGRAM

DRAWN
 CHECKED
 DIAGRAM NO.

XI.Drawing and Parts List

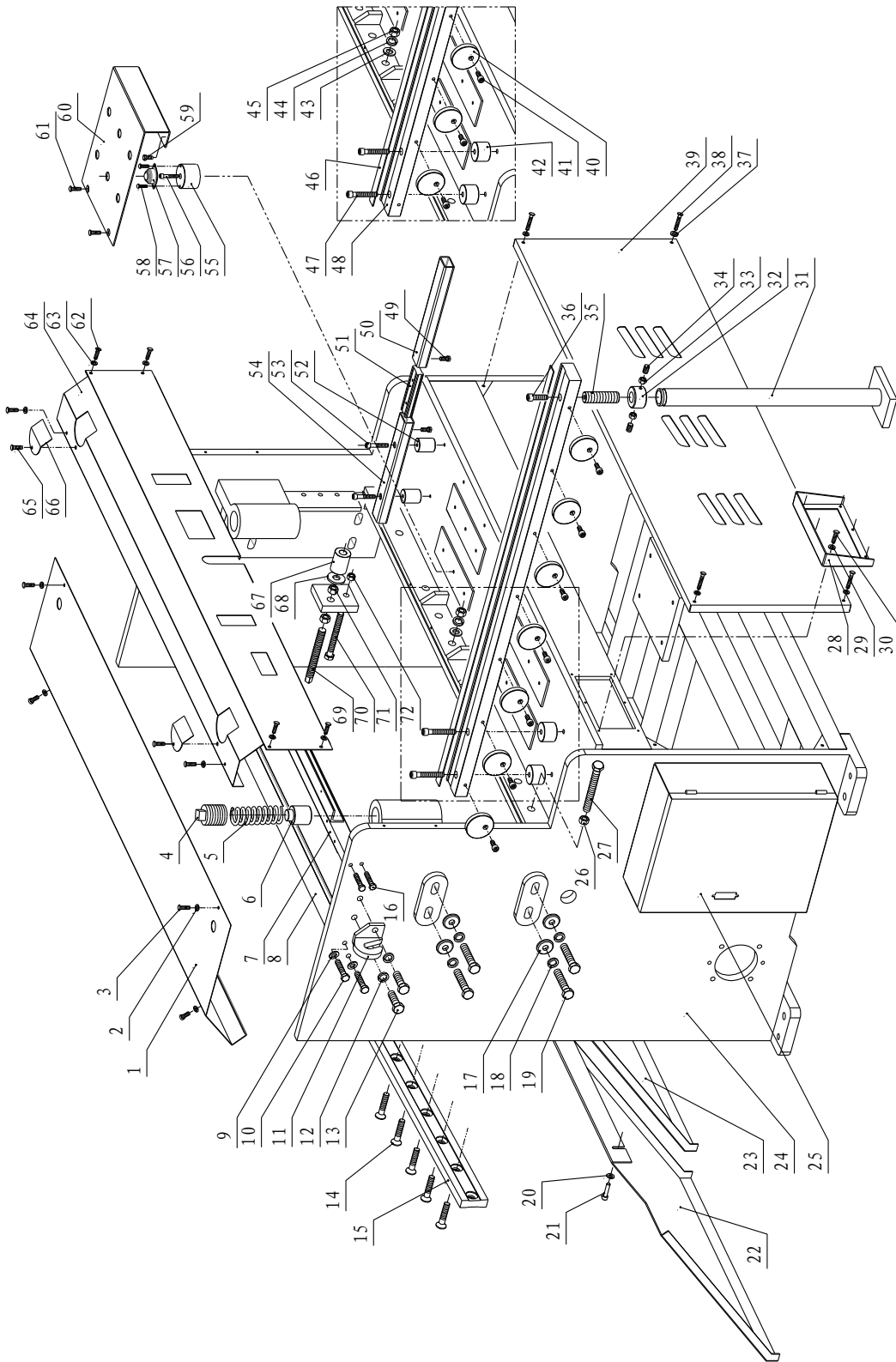

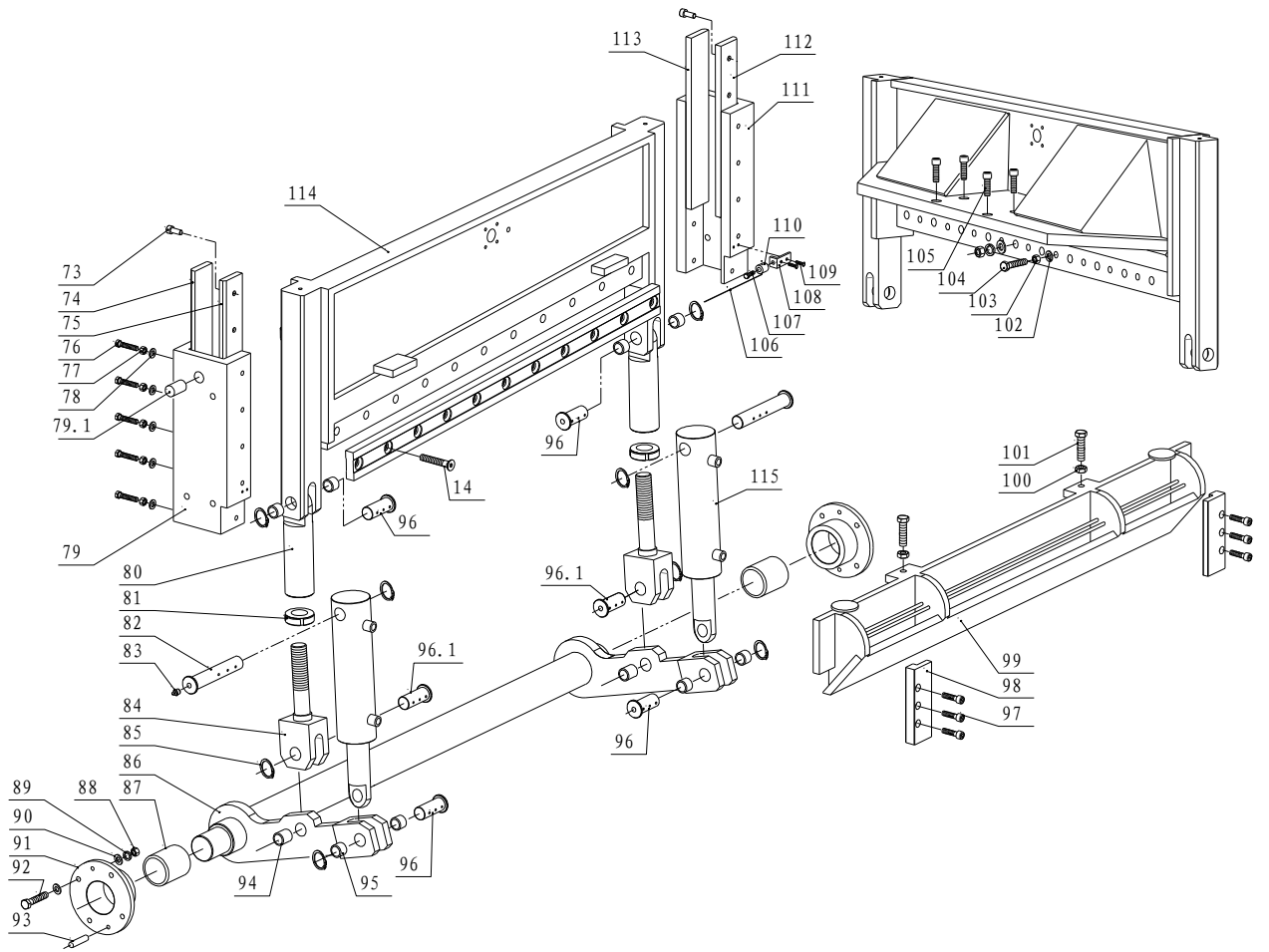

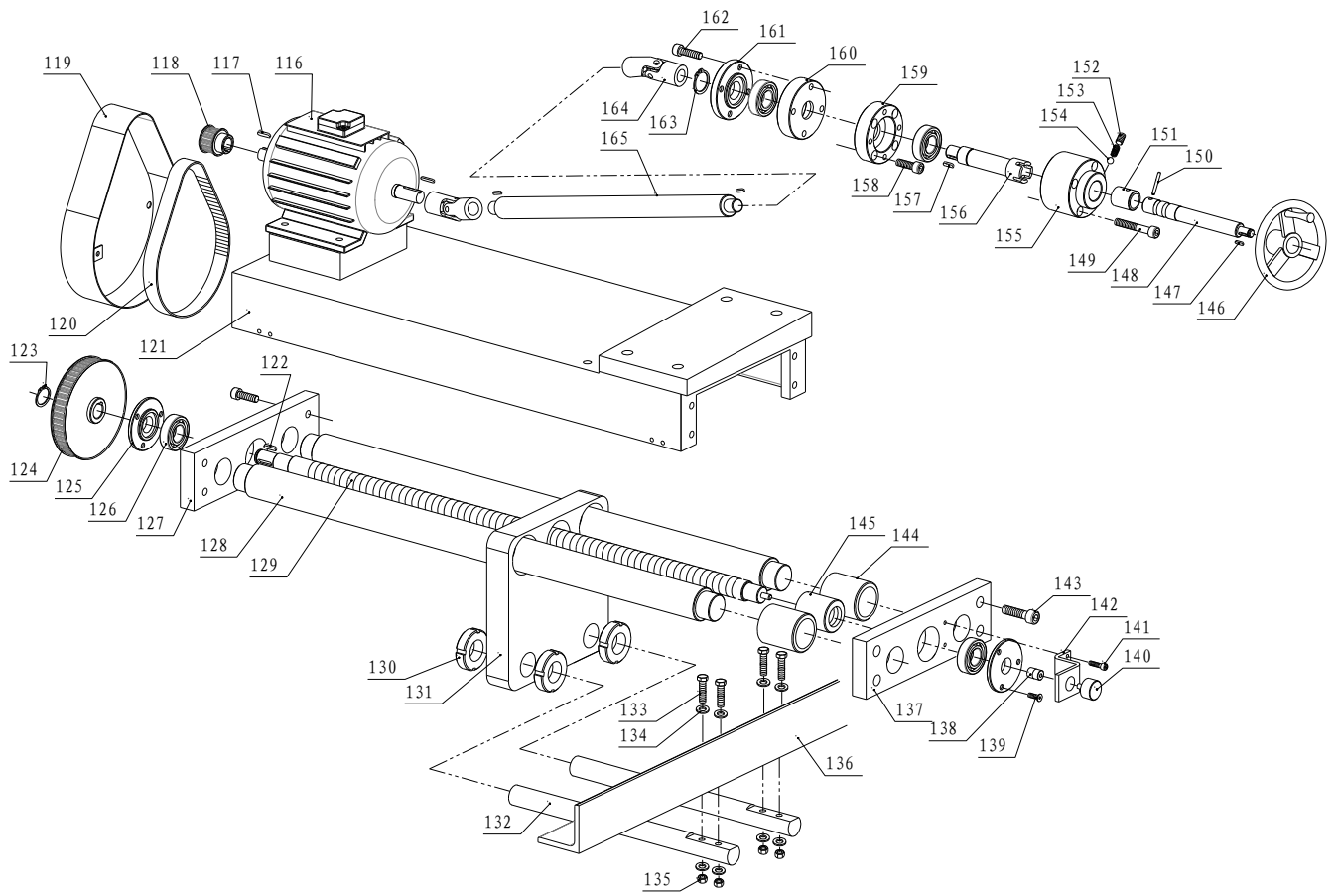

Part No.	Description	Q'ty
1	Top cover	1
2	Washer 6	4
3	Screw M6X12	4
4	stud	2
5	Spring	2
6	shaft	2
7	support	1
8	support	1
9	Washer 12	4
10	Screw M12X45	4
11	Lifting plate	2
12	Washer 16	4
13	Screw M16X40	4
14	Screw M18X1.5X90	22
15	blade	2
16	Screw M8X45	4
17	washer	8
18	Washer 16	8
19	screwM16X110	8
20	washer8	4
21	Screw M8X20	4
22	Sliding plate	1
23	Sliding plate	1
24	frame	1
25	Electrical box	1
26	Nut M16	2
27	Nut M16X110	2
28	Safety guard	1
29	Washer 5	6
30	Screw M5X16	6
31	strut	1
32	Adjustment nut	1
33	Nut M8	2
34	Screw M8X16	2
35	Adjustment screw	1
36	Screw M12X45	1
37	Washer 6	4
38	Screw M6X35	4
39	Safety guard	1
40	Limit set	7
41	Screw M8X20	7
42	Side rules pad	2

43	Washer 18	22
44	Washer 18	22
45	Nut M18X1.5	22
46	ruler	1
47	Screw M12X85	2
48	Side rule	1
49	Nut M6X12	4
50	Connecting pipe	2
51	connection plate	2
52	Support mat	4
53	Screw M8X65	4
54	Pipe of front sport	2
55	Rolling ball seat	12
56	Nut M8X55	12
57	Rolling ball	12
58	Nut M5X12	24
59	Bolt M8X16	4
60	Cover plate	2
61	Nut M6X16	4
62	Nut M6X12	6
63	Washer 6	6
64	Upper cover	1
65	Nut M6X12	2
66	Cover plate	2
67	Rubber column	2
68	mat	2
69	screw	2
70	Bolt M16X150	2
71	Nut M20	4
72	Nut M16	2
73	Nut M12X35	10
74	Left top plate	1
75	Left backup plate	1
76	Bolt M12X65	10
77	Nut M12	10
78	Washer 12	10
79	Left slide slot	1
79.1	Axis pin	2
80	Upper connecting rod	2
81	nut	2
82	Long axis	2
83	Oil cup M10X1	2
84	Lower connecting rod	2
85	Checking ring 35	8
86	Main axis frame	1

87	cover	2
88	Nut M12	8
89	Spring washer12	8
90	washer12	16
91	Fixed cover	2
92	Bolt M12X60	8
93	Round pin 10X40	4
94	cover	2
95	cover	8
96	Axis pin	4
96.1	Axis pin	2
97	Bolt M12X30	6
98	Pressing plate	2
99	Pressing bridge	1
100	Nut M16	2
101	Bolt M16X80	2
102	Washer 16	10
103	Nut M16	10
104	Bolt M16X65	10
105	Bolt M16X35	4
106	Wire ϕ 0.5	1
107	Bolt M6X12	2
108	Bending plate	2
109	Bolt M6X16	4
110	Small shaft	2
111	Right guideway	1
112	Right backup plate	1
113	Right support plate	1
114	Upper head frame	1
115	Hydraulic cylinder	2
116	Motor of backstop	1
117	Key6X30	2
118	Small belt wheel	1
119	Belt cover	1
120	Belt 255L	1
121	Fixed mount	1
122	Key 6X25	1
123	Check ring 22	1
124	Big belt wheel	1
125	Bearing cover	2
126	Bearing 6205-2RS	4
127	End plate	1
128	Guiding axis	2
129	screw	1
130	Round nut M30X1.5	4

131	Connecting plate	1
132	regulating stem	2
133	Bolt M8X45	4
134	Washer 8	8
135	Nut M8	4
136	Block angle	1
137	End plate	1
138	Spring elastic coupling	1
139	Nut M6X16	6
140	coder	1
141	Nut M5X16	2
142	Stand for coder	1
143	Nut M10X30	8
144	cover	2
145	screw	1
146	Handle wheel	1
147	Key 4X16	1
148	axis	1
149	Nut M8X65	4
150	Round pin 6X40	1
151	cover	1
152	Screw M8X8	1
153	Spring	1
154	Ball 6	1
155	Bearing bush	1
156	Shaft	1
157	Key 6X18	3
158	Screw M8X30	4
159	Bearing	1
160	Bearing	1
161	Bearing gland	1
162	Screw M8X40	4
163	Shaft Collar 25	1
164	Universal coupling	2
165	Shaft	1

Note: This manual is only for your reference. Owing to the continuous improvement of the machine, changes may be made at any time without obligation on notice. And please note the local voltage while operating this electric machine.