

HYDRAULIC IRONWORKER

Model: M55



Operation Manual

Table of contents

1. Safety	1
2. Specification	2
3. Operation and adjustments.....	5
Angle shear station	5
Bar shear station.....	6
Electric stroke control.....	7
Punch station.....	8
Notcher station	11
Optional tooling-Angle notcher	12
Optional tooling-Auto-cut.....	13
Optional tooling-Brake	14
Optional tooling-Notcher.....	15
Optional tooling-Oversize punch	17
Optional tooling-Pipe notcher	18
Optional tooling-Rod shear/multi-shear.....	19
Optional tooling-Punch	21
4. Trouble shooting	23
5. Electrical drawing.....	24
6. Drawing and part list.....	25

1. SAFETY

Warnings

Read and understand the entire owner's manual before attempting assembly or operation.

As with all machinery there are certain hazards with operation and use of the machine. Using the machine with respect and caution will considerably lessen the possibility of personal injury. However, if normal safety precautions are overlooked or ignored, personal injury to the operator may result.

This machine was designed for certain application only. We strongly recommend that this machine NOT be modified and/or used for any application other than for which it was designed. If you have any questions relative to its application DO NOT use the machine until you contact with us and we have advised you.

A. USER:

- (1).**WEAR PROPER APPAREL.** No loose clothing, gloves, rings, bracelets, or other jewelry to get caught in moving parts. No-slip foot wear is recommended. Wear protective hair covering to contain long hair.
- (2).**ALWAYS WEAR EYE PROTECTION.** Refer to ANSLZ87.1 standard for appropriate recommendations. Also use face or dust mask if cutting operation is dusty.
- (3).**DON'T OVERREACH.** Keep proper footing and balance at all times
- (4).**NEVER STAND NO TOOL.** Serious injury could occur if the cutting tool is accidentally contacted.
- (5).**NEVER LEAVE TOOL RUNNING UNTENDED.TURN POWER OFF.** Don't leave tool until it comes to a complete stop.
- (6).**DRUGS, ALCOHOL, MEDICATION.** Don't operate tool while under the influence of drug, alcohol or any medication.
- (7)**MAKE SURE TOOL IS DISCONNECTED FROM POWER SUOOLY.** While motor is being mounted, connected or reconnected.
- (8).**ALWAYS** keep hands and fingers away from the blade.
- (9).**STOP** the machine before removing chips.
- (10).**SHUT-OFF** power and clean the BAND SAW and work area before leaving the machine.

B. USE OF MACHINE:

- (1).**REMOVE ADJUSTING KEYS AND WRENCHES.** From habit of checking to see that keys and adjusting wrenches are removed from tool before turning it "on".
- (2).**DON'T FORCE TOOL.** If you will do the job better and be the rate for which it was designed.
- (3).**USE RIGHT TOOL.** Don't force tool or attachment to a job for which it was not designed.
- (4).**SECURE WORK.** Use clamps or a vise to hold work when practical. It's safer than using your hand frees both hands to operate too.
- (5).**MAINTAIN TOOLS IN TOP CONDITION.** Keep tools sharp and clean for best and safest performance. Follow instructions for lubricating and changing accessories.
- (6).**USE RECOMMENDED ACCESSORIES.** Consult the owner's manual for recommended accessories. The use of improper accessories may cause hazards.
- (7).**AVOID ACCIDENTAL STARTING.** Make sure switch is in "OFF" position before plugging in power cord.
- (8).**Do not operate with guard removed.** Physical barriers and guards have been designed and installed to protect the

operator from moving parts that can pinch, cut and crush,. If it is necessary to remove guarding when serving the ironworker, immediately replace guards after service and prior to power being restored to the machinery.

(9). Hydraulic fluid hazard. Hydraulic hoses are under pressure. Pressurized fluid can pierce skin and cause severe injury. To avoid physical hazard, always wear personal protective equipment when serving/maintaining the ironworker.

C.WORKING ENVIRONMENT:

(1).**KEEP WORK AREA CLEANS.** Cluttered areas and benches invite accidents.

(2).**DON 'T USE IN DANGEROUS ENVIRONMENT.** Don't use tools in damp or wet locations, or expose them to rain. Keep work area well-lighted.

(3).**KEEP CHILDREN AND VISITORS AWAY.** All children and visitors should be kept a safe distance from work area.

(4).**DON'T** install & use this machine in explosive, dangerous environment.

D. MAINTENANCE:

(1).**DISCONNECT** machine from power source when making repairs.

(2).**CHECK DAMAGED PARTS.** Before further use of the tool, a guard or other part that is damaged should be carefully checked to ensure that it will operate properly and perform its intended function check for alignment of moving parts, binding of moving parts, mounting, and any other conditions that may affect its operation. A guard or other part that is damaged should be properly repaired or replaced.

(3).**DISCONNECT TOOLS** before servicing and when changing accessories such as blades, bits, cutters, ect.

2. SPECIFICATION



Our hydraulic ironworker M55 is designed to punch, shear and notch mild steel plate, barstock and angle. A wide range of accessories are available to fabricate rod and square stock, sheet metal and pipe. It operate by applying hydraulic force to a moving center, the center moves within a frame in a simple, vertical path and exerts force through shear blades, punch and dies, notchers, brake dies or bump-die tooling upon A36 mild steel. It designed for single operator use only; unless otherwise identified with a D.O./Dual operator designation.



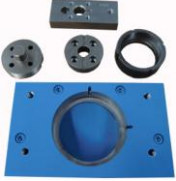

Item No	381111	
Model	M55	
Punch capacity	Diameter	1-1/16" diameter in 5/8" plate
	Throat depth	7-1/2"
	Stroke	1-1/4"
Flat bar shearing	Max. width	1/2" x 12" or 3/8" x 14"
	Max. capacity	3/4" x 4"
	Max. round	7/8"
	Max. square	7/8"
Angle shearing	Max. capacity	4"x4"x1/4" or 3"x3"x3/8"
	Work height	40"
Open station	Throat depth	7"
	Open height	8"
	Shut height	6-3/4"
	Work height	35-1/4"
Motor power	4 KW	
N.W/G.W	1060/1160 KG	
Packing size	115x113x152 CM	

Standard tooling:

- (1) Punch die: 15/16" or 22 mm
- (2) Flat bar shear
- (3) Angle steel shear

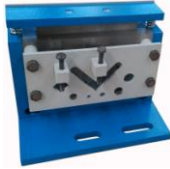
Optional tooling:

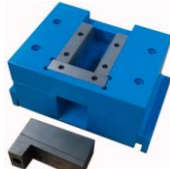
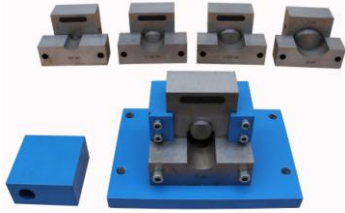
1	55ton-2000	Punch dies 7 sets inch dies, include:1-1/16", 13/16", 11/16", 9/16", 7/16", 5/16", 3/16" Punch dies 9 sets metric dies, including: 8,10,12,13,14,16,18,19,20mm	
2	55ton-3000	Punch heterotypic hole	
3	55ton-4000	Right angle notcher	

4	55ton-5000	Angle steel: 2"x2" Square: 3/4"x3/4" Round (OD):3/4", 5/8", 3/8", 1/2", 1/4" Flat steel: width 6" x 5/16"mm	
5	55ton-6000	Brake dies	
6	55ton-8000	Slot die	
7	55ton-9000	Pipe notcher, includes 3/4", 1", 1-1/4", 1-1/2", 2"	
8	55ton-9100	Round pipe shearing die	
9	55ton-9200	Gauging table kit and fabricators protector	

Operation diagram

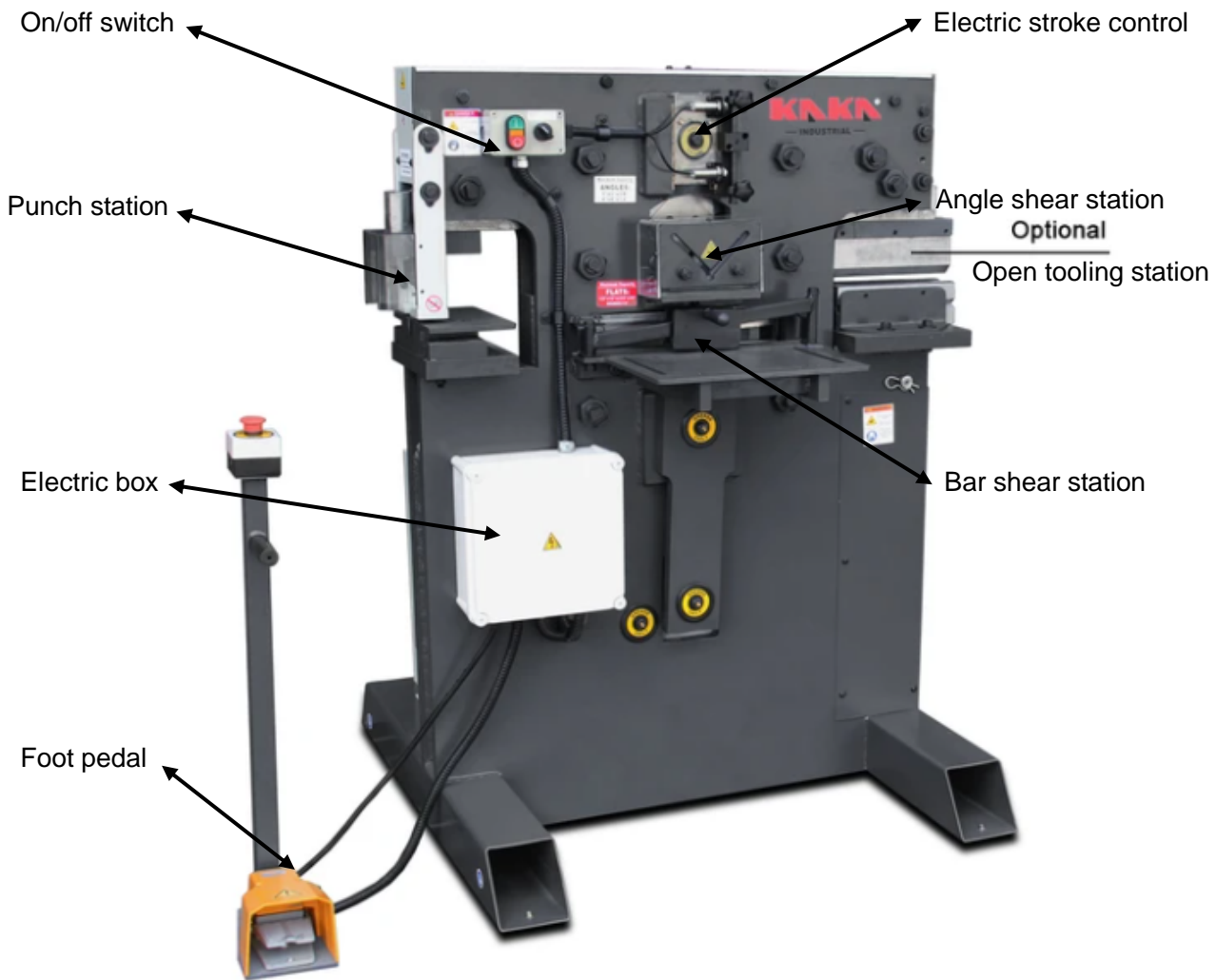

3. OPERATION AND ADJUSTMENT

ANGLE SHEAR STATION

Warnings

Your Ironworker may include an angle iron shear as a standard feature. The angle shear will provide a distortion and burr free shear cut to mild steel angle stock as listed in the ironworker specifications as well as described on the capacity labels positioned at the angle shearing station. The angle shearing station on the ironworker allows for straight cutting applications. An oversized material hold down adjusts with a simple thumb crank to safety restrain the material being cut. Integrated angle shear are factory tuned to proper clearances and are ready to begin shearing operations. (Shear blades are wearing parts and will need to be maintained or replaced over time. Refer to maintenance manual for blade maintenance, removal and replacement.)

Safe operation

Observe the following guidelines when operating the angle shear station:

Never exceed the capacities of the machine or tooling as described in the ironworker specifications or listed at the tooling

station.

Check shear blade clearance at every tooling change or extended shear operation. Maintain proper operating clearance at bar shear and angle shear stations. Refer to maintenance manual for tolerance adjustment instructions. Failure to maintain clearance will damage shear blades and support brackets.

Fully engage the material hold-down with the material being cut.

Do not stack material to cut in the shear station.

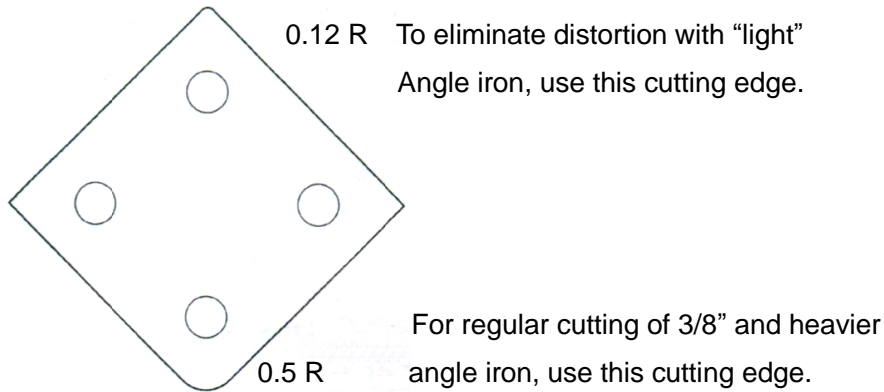

Perform complete shear operations only – partial shear cuts may jam the drop off side of the frame and could result in breakage and operator injury.

Do not shear angle smaller than the hold-down will accommodate.

Angle shear operation.

- (1) Clear shear station of any tools or debris prior to powering the machine on.
- (2) Turn machine on. The shear blades will be in their neutral position. Place angle iron into the material hold-down and position your cut mark adjacent to the moving shear blade.
- (3) Secure the angle iron in the material hold-down by engaging the handscrew into material.
- (4) Clear your hands from the working area and depress the foot pedal to activate the shear station.
- (5) When the cut is complete, release the foot pedal to automatically return the shear blades to their neutral position. If equipped with the hydraulic hold-down feature, the hold-down will retract when pressure on the foot pedal is released at the end of the cut cycle.
- (6) Reverse the thumb screw to raise the material hold-down and remove your material.

BAR SHEAR STATION

⚠ Warnings

Your ironworker may include a bar shear as a standard feature. The bar shear will provide a distortion and burr free shear cut to mild steel bar stock as listed in the ironworker specifications as well as described on the capacity labels positioned at the bar shear station. The bar shear allows for straight or angled cutting operations. The material hold down adjusts with a simple hand crank to safely restrain the material being cut.

Bar shears are factory tuned to proper clearances and are ready to begin shearing operations.

Shear blades are wearing parts and will need to be maintained or replaced over time. Refer to the maintenance manual for blade maintenance, removal and replacement.

Safe operation

Observe the following guidelines when operating the bar shear station:

Never exceed the capacities of the machine or tooling as described in the ironworker specifications or listed at the tooling at the tooling station.

Maintain correct operating clearance at bar shear and angle shear stations. Refer to the maintenance manual for tolerance adjustment instructions. Failure to maintain proper blade clearance will damage shear blades and shear blade support.

Fully engage the material hold-down with the material being cut.

Do not stack material to cut in the shear station.

Per form complete shear operations only-partial shear cuts may jam the drop off side of the frame and could result in breakage and operator injury.

Use shearing aids when working with small items at the shear station.

Bar shear operation

- (1) Clear bar shear station of any tools or debris prior to powering the machine on.
- (2) Turn machine on. The shear blades will be in their neutral position. Place bar stock on the feed table and push the material under the material hold-down. Position your desired cut mark adjacent to the moving shear blade.
- (3) Secure the bar stock in the material hold-down by engaging the handscrew into the material.
- (4) Clear your hands from the working area and depress the foot pedal to activate the shear station.
- (5) When the cut is complete, release the foot pedal to automatically return the shear blades to their neutral position.
Reverse the hand screw to raise the manual material hold-down and remove your material.

ELECTRIC STROKE CONTROL



Warnings

Electric stroke control is standard on ironworker. Stroke control enables the ironworker operator to shorten up and down stroke with minor adjustment of two hand screws. Utilize stroke control for precision bending with your brake tooling, when using embossing or bump dies or to simply increase production from your punch, notch or shear stations.

Setup

Electric stroke control is factory installed and arrives fully set up for immediate use.

Safe operation

Observe the following guidelines when using and adjusting the electric stroke control function.

Read, understand and follow punching, notching and shearing tolerances as described in related chapters of this manual.

Never exceed the capacities of the machine or tooling as described in the ironworker specifications or listed at the tooling station.

Keep limit switches free of dirt and grime.

Never remove stroke retention nuts from factory setting,

Never reverse stroke limit switches.

Confirm that red light is illuminated. If not illuminated, machine cycle is not complete and potential heat-up may occur.

Electric stroke control operation

Set upstroke for rapid cycling of your punching, shearing and notching stations.

- (1) Power machine on and use the jog function of your electric foot pedal to bring tooling down to rest just above the material being worked.
- (2) Turn machine off.
- (3) Adjust upper handle with tapered collar to engage limit switch.
- (4) Power machine on. Tooling will stay in set position. Top limit switch will be showing a red light.
- (5) Remove material from tooling station and cycle machine. Tooling should return to pre-set position. Red light will be on.
- (6) Place material in tooling station and cycle machine.

Set downstroke for bump die operation.

- (1) Power machine on and use the jog function of your electric foot pedal to bring ram down to engage tooling, jog ram to push bump die tooling to the specified depth.
- (2) Turn machine off.
- (3) Adjust lower handle with tapered collar to engage limit switch.
- (4) Power machine on. Ram will return to top of stroke.
- (5) Cycle machine to insure proper stroke depth.
- (6) Place material in tooling station and cycle machine.

Set downstroke for brake operation

- (1) Power machine on and use the jog function of your electric foot pedal to bring ram down to engage tooling with material.
- (2) Jog ram to push brake die tooling to specified depth/brake angle.
- (3) Turn machine off.
- (4) Adjust lower handle with tapered collar engage limit switch
- (5) Power machine on. Ram will return to top of stroke. Red light will be on.
- (6) Place test material in tooling station and cycle machine to insure proper stroke depth and material brake.

PUNCH STATION



Warnings

Your ironworker is capable of punching materials as listed in the ironworker specifications as well as described on the capacity labels positioned adjacent to the punch station.

Setup

Punch and dies are wearing parts and will need to be maintained or replaced over time. Refer to the maintenance manual for removal and replacement instructions. When changing the punch and die during typical operation please observe the following steps.

Turn off power to machine by depressing the red stop/off button or lockout upstream power at the main electrical panel.

- (1) Swing stripper bar away by loosening 4 bolts (2 on either side of punch station) with a 3/4" wrench. After swinging stripper bar away, re-tighten one bolt prevent it falling back on you.
- (2) Remove punch by loosening the punch nut assembly with factory supplied wrench.
- (3) Remove die by loosening the set screw at the side or front edge of the punch table and then lifting die from the die holder. If the die resists removal gently tap the die from the underside of the punch table to loosen the die for removal.

- (4) Install new die and tighten set screw. If loading a shaped die. Align the whistle spot with the set screw and tighten.
- (5) Install new punch and tighten punch nut with wrench. If using a shaped punch, align the locating keystone of the punch with the corresponding slot within the punch stem assembly and tighten the punch nut with the wrench.
- (6) Check for punch and die alignment by powering up the machine and inching down the punch to meet the die with the foot pedal. Check to see that the punch is centered in the die.
- (7) In the event that the punch and die are not aligned, loosen the bolts under the table allowing the table to be moved to center the die. When aligned, tighten the table bolts to secure the table.
- (8) Loosen bolts and swing the stripper bar back in place. Adjust of stripper bar for minimal clearance between the top of the material and the bottom of the stripper.

Safe operation

Please observe the following guidelines when operating the punch station:

Follow manufacturers punch and die clearance recommendations. Follow punch tonnage requirements (figure 1).

Never exceed the capacities of the machine or tooling as described in the ironworker specifications or listed at the tooling station.

The thickness of the material you are punching should not exceed the diameter of the punch being used.

Check punch and die alignment after every tooling change or extended punch operation.

Adjust the punch stripper supplied with your ironworker to allow for material positioning and material stripping.

Do not stack material to punch in the punching station.

Use one or two drops of oil at the punch to aid in stripping material from the punch as well as to extend the life of the punch tooling.

Punch complete holes only-partial holes will side load the punch tooling and could result in punch breakage and operator injury.

Use punching aids when working with small items at the punch station.

Punch operation

- (1) Clear the punch station of any tools or debris prior to powering the machine on.
- (2) Place the material to be punched between the punch and die. Check to see that your material is spanning the stripper plate and that adequate material is available to safely position the material.
- (3) Clear your hands from the working area and depress the foot pedal to move the punch through the material and into the die.
- (4) When the punch is complete, release the foot pedal to automatically strip the material from the punch and return the punch to its neutral position.

Punch and die operating clearances

Maintain the following clearance between punch and die.

Material thickness	Total clearance
16 gauge and lighter	0.006"
15 gauge – 13 gauge	0.010"
3/32" – 5/32"	1/64"
3/16" – 15/32"	1/32"
1/2" – 23/32"	1/16"
3/4" and heavier	3/32"

Punching capacities

You can determine the tonnage required to punch A36 mild steel (yield strength 36,300 psi tensile) by applying the following formulas for round or shaped holes. For materials other than mild steel please refer to the multiplier table.

Figure 1 – Punch tonnage requirements

Stock thickness	Hole diameter														
	1/8"	3/16"	1/4"	5/16"	3/8"	7/16"	1/2"	9/16"	5/8"	11/16"	3/4"	13/16"	7/8"	15/16"	1"
26 ga (0.0179")	0.18	0.27	0.36	0.45	0.54	0.63	0.72	0.81	0.90	0.99	1.07	1.16	1.25	1.34	1.43
24 ga (0.0239")	0.24	0.36	0.48	0.60	0.72	0.84	0.96	1.08	1.20	1.31	1.43	1.50	1.67	1.89	1.91
22 ga (0.0299")	0.30	0.45	0.60	0.75	0.90	1.05	1.20	1.35	1.50	1.65	1.80	1.95	2.10	2.24	2.39
20 ga (0.0359")	0.36	0.54	0.72	0.90	1.08	1.26	1.44	1.62	1.80	1.98	2.1	2.33	2.51	2.69	2.87
18 ga (0.0478")	0.48	0.72	0.96	1.20	1.43	1.67	1.91	2.15	2.39	2.63	2.87	3.1	3.34	3.58	3.82
16 ga (0.0598")	0.60	0.90	1.20	1.50	1.79	2.09	2.39	2.69	2.99	3.29	3.59	3.89	4.19	4.49	4.78
14 ga (0.0747")	0.75	1.12	1.49	1.87	2.24	2.61	2.99	3.36	3.73	4.11	4.48	4.86	5.23	5.60	5.97
12 ga (0.1046")	1.05	1.57	2.09	2.62	3.14	3.66	4.18	4.71	5.23	5.75	6.28	6.80	7.32	7.85	8.75
10 ga (0.01345")		2.02	2.69	3.36	4.04	4.71	5.38	6.05	6.73	7.40	8.07	8.74	9.42	10.09	10.76
3/16" (.187")		2.81	3.74	4.68	5.61	6.50	7.48	8.42	9.35	10.29	11.22	12.16	13.09	14.03	14.96
1/4" (0.25")			5.00	6.25	7.50	8.75	10.00	11.25	12.50	13.75	15.00	16.25	17.50	18.75	20.00
3/8" (0.375")					11.25	13.13	15.00	16.88	18.75	20.63	22.50	24.38	26.25	28.13	30.00
1/2" (0.5")							20.00	22.50	25.00	27.50	30.00	32.50	35.00	37.50	40.00
5/8" (0.625")									31.25	34.38	37.50	40.63	43.75	46.88	50.00
3/4" (0.75")											45.00	48.75	52.50	56.25	60.00
7/8" (0.875")													61.25	65.63	70.00
1" (1")															80.00

Round holes

Punch dia. X Material thickness x 80 = Tons of pressure required

Example: how many tons of force do I need to punch a 3/8" hole in 1/4" mild steel ?

$$0.375 \times 0.25" \times 80 = 7.50 \text{ tons}$$

Punch tonnage requirement (figure 1)

Shaped holes

1/3" punch perimeter x material thickness x 80 = tons of pressure required

Example: how much force do I need to punch a 3/8" x 1" rectangular hole in 1/4" mild steel

$$(0.33" \times 2.75") \times 0.25" \times 80 = 18.1 \text{ tons}$$

Material multiplier

When punching materials other than mild steel first calculate tonnage as shown above then apply the multiplier for the listed material.

Aluminum (2024-0)	0.36"
Brass (1/4 hard)	0.70"
Copper (1/2 hard)	0.52"
Steel (50% carbon)	1.60"
Steel (cold rolled) (1018)	1.24"
Stainless steel (303)	1.5"

NOTCHER STATION

Warnings

Your ironworker includes a notcher tool as a standard, integrated feature. Notcher tooling includes one moving, three sided top notcher blade and three, four sided bottom blades set into a base table assembly. Notcher tooling creates a two or three sided shear cut in mild steel by passing the top notcher blade through the bottom stationary blades.

The integrate notcher is factory tuned to proper clearances and is ready to begin notching operations. Notcher blades are wearing parts and will need to be maintained to replaced over time. Refer to the maintenance manual for blade maintenance, removal and replacement.

Safe operation

Observe the following guidelines when operating the notcher station.

Never exceed the capacities of the machine or tooling as described in the ironworker specifications or listed at the tooling station.

Check notcher blade clearance at every tooling change or extended notcher operation. Maintain 0.010" clearance between top and bottom notcher blades at all times. Failure to maintain clearance will damage blades and support pockets.

Cut with a minimum two of three sides of the blade surfaces engaging the material being notched. Cutting on one blade surface may overload the blades and result in tooling damage or injury to the operator. See figures A,B and C.

Do not stack material to cut in the notcher station.

Perform complete notch operations only-partial notch cuts may jam the drop off side of the tooling and could result in tooling damage and operator injury.

Use notching aids when working with small items at the notcher station.

Notcher operation

- (1) Clear the feed table of the notcher station of any tools or debris prior to powering the machine on.
- (2) Turn machine on. The top notcher blade will be in the neutral position. Push the material under the tooling guard and into the blade area. Position your material to the desired cut.
- (3) Clear your hands from the working area and depress the foot pedal to activate the notcher station. When the cut is complete, release the foot pedal to automatically return the top notcher blade to the neutral position.

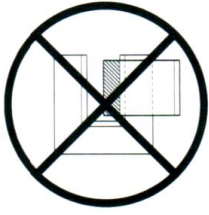

Figure A

Incorrect use

material supported on one blade

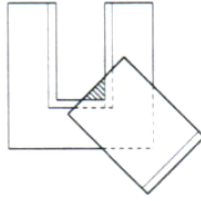

Figure B

Correct use

material supported by two blades

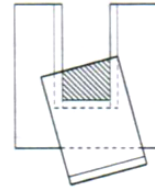

Figure C

Correct use

material supported by three blades

OPTIONAL TOOLING-ANGLE NOTCHER

Warnings

Optional angle notcher tooling will provide a distortion and burr free, two-sided, 92 degree shear cut to mild steel bar, plate or angle stock. Common use of this tooling is in the fabrication of angle iron frames. Please review capacity labels positioned at the angle notching station.

Setup

Optional tooling and accessories fit within the open station of the machine. Your angle notcher is equipped with one, two sided top notcher blade and two, four-sided bottom blades. The top blade is mounted on guide ins and return springs of the tooling base. The moving “center” of the ironworker, pushes on the top angle notch blade via the accessory push block. If ordered as a factory installed option, your angle notcher assembly is setup for immediate operation. If ordered as an option, the punch station of the machine must be cleared of any existing tooling, material or debris prior to tooling installation. Notcher blades are wearing parts and will need to be maintained or replaced over time. Refer to the maintenance manual for blade maintenance, removal and replacement. To setup your angle notching station please observe the following steps.

Turn off power to machine by depressing the red stop/off button or lockout upstream power at the main electrical panel.

Install the push block:

Install the push block to the moving center. The V-shaped end of the push block should be pointing away from the machine. Secure the push block with bolts provided.

Install the V-Notcher assembly:

- (1) Place the angle notcher assembly on the ironworker support table with the V pointing away from the machine.
- (2) Loosely secure the table from the underside of the base with four 1/2” bolts and washers (provided)
- (3) Check for push block and top blade alignment by powering on the machine and slowly inching down the push block to meet the top blade with the foot pedal. Power the machine off.
- (4) In the event that the push block and top blade are not aligned, simply loosen the bolts under the table allowing the table to be moved to center the push block centerline to the top blade. When aligned, tighten the table bolts to secure the table.
- (5) Install the angle notcher guard with the bolts provided.

Safe operation

Observe the following guidelines when operating the angle notcher station.

Never exceed the capacities of the machine or tooling as described in the ironworker specifications or listed at the tooling station.

Check angle notcher blade clearance at every tooling change or extended notcher operation. Maintain 0.010 clearance between top and bottom notcher blades at all times. Failure to maintain clearance will damage blades and support pockets. Cut with a minimum of two sides of the blades surfaces engaging the material being notched. Cutting on one blade surface may overload the blades and result in tooling damage or injury to the operator.

Do not stack material to cut in the angle notcher station.

Perform complete notch operations only-partial notch cuts may jam the drop off side of the tooling and could result in breakage and operator injury.

Use notching aids when working with small items at the notcher station.

Angle notcher operation

- (1) Clear the feed table of the notcher station of any tools or debris prior to power the machine on.
- (2) Turn machine on. The top notcher blade will be in the neutral position. Push the material under the tooling guard and into the blade area. Position your material to the desired cut.
- (3) Clear your hand from the working area and depress the foot pedal to activate the notcher station. When the cut is complete, release the foot pedal to automatically return the top notcher blade to the neutral position.

OPTIONAL TOOLING-AUTO-CUT

Warnings

Auto-cut tooling is a very useful accessory when production cutting long lengths of material to repeatable lengths. Compatible with most late models, this tooling features a rugged solid-steel spring loaded switch housing, guarding snoot, 1" x 48" machined back-gauge rod and electrical control. The accessory actuated the cutting operation when the plunger switch is activated.

Setup

Turn off power to machine by depressing the red stop/off button or lockout upstream power at the main electrical panel.

Install an auto-cut tool:

- (1) Locate the operations control box on the feed side of the machine.
- (2) Thread the back gauge rod into the threaded 1" hole in the back of the machine.
- (3) Install the cross block and actuator rod to the back gauge rod.
- (4) Adjust the actuator rod towards the back of the machine and align so that the material being sheared will activate the actuator plunger. Adjust the guarding snoot to be clear of the material being sheared.
- (5) Attach the auto-cut tool M12 male control cable to the 4-pin female auto-cut port.
- (6) Turn machine ON and turn the power selection at the operations control box to auto-cut. The power selection switches power and control from the ironworker foot-pedal to the auto-cut tool.
- (7) With the shear stations clear of tools and debris, test the auto-cut operation by depressing the actuator plunger. The machine should perform a full cut cycle and return to the neutral position.

Safe operation

Observe the following guidelines when operating the auto-cut tool:

Never exceed the capacities of the machine or tooling as described in the ironworker specifications or listed at the tooling

station.

Check shear blade clearance at every tooling change or extended shear operation. Maintain proper operating clearance at bar shear and angle shear stations. Failure to maintain clearance will damage shear blades and support brackets.

Fully engage the material hold-down with the material being cut.

Do not stack material to cut in the shear station.

Perform complete shear operations only-partial shear cuts may jam the drop off side of the frame and could result in breakage and operator injury.

Do not shear angle or flat stock smaller than the hold-down will accommodate.

Auto-cut operation

- (1) Clear shear station of any tools or debris prior to powering the machine on.
- (2) Place iron into the material hold-down and position your cut mark adjacent to the moving shear blade.
- (3) Secure the iron in the material hold-down by engaging the hand screw or flat bar hold-down into the material.
- (4) Slide the auto-cut actuator to meet the leading edge of the material projecting through the shear station.
- (5) With the power off, activate the plunger by pushing the actuator into the material. Tighten the actuator rod to the back gauge rod.
- (6) Test cut by turning the machine on.
- (7) Release hold-down pressure slightly to allow material to be pushed through the shear station.
- (8) Push the material through the shear station to engage the actuator plunger.
- (9) The machine will cycle and shear the specified material.
- (10) Check the cut material dimension and adjust as necessary for production cutting.

OPTIONAL TOOLING-BRAKE

Warnings

Brake tooling is available in 7", 8", 10" and 12" assemblies for your ironworker. Brake tooling will allow for the graduated bending of 1/16", 3/16", 1/8" and 1/4" flat stock up to 90 degree. This tooling is most effective when operated with the factory installed electric stroke control feature.

Setup

Brake tooling can be accommodated in either the open or punch station of the machine. Brake tooling includes one mounting bracket to secure the "punch" to the center of the machine. One "punch", one "4-way die", and two bottom brackets that secure the "die" to the base table. The moving "center" of the ironworker, pushes the top punch into the shaped die to bend the specified material. If ordered as a factory installed option, your brake assembly is setup for immediate operation. If ordered as an option, the open or punch station must be cleared of any existing tooling, material or debris prior to tooling installation. To setup your brake, please observe the following steps.

Install the punch holder:

- (1) Remove all tooling and guarding from the open or punch station.
- (2) Secure the punch holder to the moving "center" with bolts provided. The 1/2" tapped hole is positioned to the outside of the machine.
- (3) Position punch in the holder so that the milled relief in the keyway slips over the holder bolt. Tighten set screws in the holder to secure the punch.

Install the 4-way die:

- (1) Place the die assembly on the ironworker support table.
- (2) Loosely secure the two support brackets to the support table from the underside of the base with four 1/2" bolts, nuts and washers (provided).
- (3) Check for punch and die alignment by powering on the machine and slowly inching down the punch to meet the bottom die with the foot pedal. Power the machine off.
- (4) In the event that the punch and die are not aligned, simply loosen the bolts under the table allowing the die block to be moved to center the punch. When aligned, tighten the table bolts to secure the table.
- (5) Select 1/16", 3/16", 1/8" or 1/4" test material for bending. Rotate your four-way die to your selected material thickness. Power the machine on and jog the center down till the punch pushes the sample material into the die. If the punch stops before the material has been formed to a 90 degree angle, a small steel shim must be placed between the die and support table.
- (6) Re-install all guarding to the machine prior to machine use.

Safe operation

Observe the following guidelines when operating the brake station.

Never exceed the capacities of the machine or tooling as described in the ironworker specifications or listed at the tooling station.

Keep the brake tooling clean.

Check brake clearance and alignment at every tooling change, maintenance cycle or extended brake operation. Failure to maintain proper clearance may damage punch, die and support brackets or adjacent tooling.

Brake material towards the center of the brake length.

Do not stack material in the brake station.

Use brake aids when working with small items at the brake station.

When not in use, remove the brake die from the holder.

Brake operation.

- (1) Clear the station of any tools or debris prior to powering the machine on.
- (2) Turn the ironworker on and place the material to be "broken" on top of the bottom die.
- (3) Center your material within the length of the bottom die. Bending material to the front or back of the brake die may damage your ironworker.
- (4) Position your material for the desired brake. Clear your hands from the working area and depress the foot pedal to activate the brake station. When the brake operation is complete, release the foot pedal to return the punch to the neutral position.

OPTIONAL TOOLING-NOTCHER

Warnings

Optional notcher tooling will provide a distortion and burr free, three-sided shear cut to mild steel bar, plate, or angle stock as listed in the ironworker specifications as well as the capacity labels positioned adjacent to the notching station. The optional notcher tooling for ironworker allows for shaped, straight or angled notch cutting applications.

Setup

Optional tooling and accessories fit within the open station of the machine. Optional notcher tooling is equipped with one, three-sided top notcher blade and three, four-sided bottom blades. The top blade is mounted to the moving “center” of the ironworker, while the bottom three blades are secured into a base housing. If ordered as a factory installed option, your notcher assembly is setup for immediate operation. If ordered as an option, the open cavity of the machine must be cleared of any existing tooling, material or debris prior to tooling installation. Notcher blades are wearing parts and will need to be maintained or replaced over time. Refer to the maintenance manual for blade maintenance, removal and replacement. To setup your notching station, observe the following steps.

Turn off power to machine by depressing the red stop/off button or lockout upstream power at the main electrical panel.

Install the top notcher blade:

- (1) Swing the notcher guard assembly up and away from the notcher table.
- (2) Install the top notcher blade with the keyway up and the “foot” of the blade facing the center of the machine. Secure the top blade using the two 3/8” socket head cap screws. Tighten bolts.

Install the notcher table:

- (1) Install the notcher table assembly to the base table. The notcher table includes three blades secured within the table housing. Install with the open “U” facing the center of the machine. The guide foot of the top blade should be centered within the base table blades.
- (2) Loosely secure the table from the underside of the base with four bolts and washers (provided).
- (3) Check for tip and bottom blade alignment by powering up the machine and slowly inching down the top blade to meet the bottom blades with the foot pedal. Power the machine off.
- (4) Using a feeler gauge, adjust the clearance between the perimeter of the top and bottom blades to allow for 0.010” clearance on all three sides.
- (5) In the event that the top and bottom blades are not aligned, simply loosen the bolts under the table allowing the table to be moved to center the top blade within the bottom blades. When aligned, tighten the table bolts to secure the table.
- (6) Adjust the four set screws at the sides of the notcher table to engage the base notcher table to the base table. Lock the four 3/8” nuts in place to secure the set screws in place. These added fixtures are to provide additional support to the base table during the notching operation.
- (7) Swing the notcher guard back in place.

Safe operation

Observe the following guidelines when operating the notcher station.

Never exceed the capacities of the machine or tooling as described in the ironworker specifications or listed at the tooling station.

Check notcher blade clearance at every tooling change or extended notcher operation. Maintain 0.010” clearance between top and bottom notcher blades at all times. Failure to maintain clearance will damage blades and support pockets.

Cut with a minimum two of three sides of the blade surfaces engaging the material being notched. Cutting on one blade surface may overload the blades and result in tooling damage or injury to the operator. See figures A.B.C.

Do not stack material to cut in the notcher station.

Perform complete notch operations only-partial notch cuts may jam the drop off side of the tooling and could result in breakage and operator injury.

Use notching aids when working with small items at the notcher station.

Notcher operation

- (1) Clear the feed table of the notcher station of any tools or debris prior to powering the machine on.
- (2) Turn machine on. The top notcher blade will be in the neutral position. Push the material under the tooling guard and into the blade area. Position your material to the desired cut.
- (3) Clear your hands from the working area and depress the foot pedal to activate the notcher station. When the cut is complete, release the foot pedal to automatically return the top notcher blade to the neutral position.

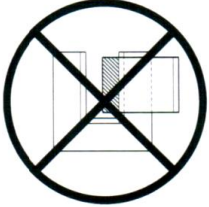

Figure A

Incorrect use

material supported on one blade

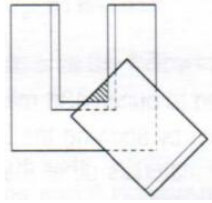

Figure B

Correct use

material supported by two blades

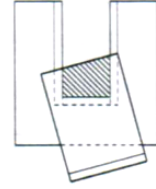

Figure C

Correct use

material supported by three blades

OPTIONAL TOOLING-OVERSIZE PUNCH

Warnings

This ironworker allow for oversize punch tooling to be installed in either the punch station or the open station. Refer to ironworker accessories specifications for capacities of oversize punch tooling.

Setup

Oversize punch tooling includes an oversize stripper' oversize punch holder assembly, oversized die table or oversized pedestal die table and an oversized wrench. Punch and dies are wearing parts and will need to be maintained or replaced over time, refer to the maintenance manual for removal and replacement instructions. When installing oversize punch and die tooling please observe the following steps.

Turn off power to machine by depressing the red stop/off button or lockout upstream power at the main electrical panel.

Install the oversize punch holder:

- (1) Oversize punch tooling can be installed in wither the punch station or the opposite, open station end of the ironworker. Remove existing tooling or debris from installation site.
- (2) Install oversize punch block/stem assembly to the moving center with hardware provided. Tighten assembly to moving center.
- (3) Insert oversize punch in oversize punch nut and thread onto oversize punch block/stem assembly. Tighten with wrench provided. If using a shaped punch, align the locating keystone of the punch with the corresponding slot within the punch stem assembly and tighten the punch nit with the wrench.

Install the oversize pedestal die table:

- (1) Clear the ironworker base table of any debris.
- (2) Install the oversize die table with the die opening facing away from the ironworker. Align the slotted holes of the die table with the base table holes and insert hardware provided.
- (3) With die table hardware loosely installed, insert die into die holder and secure with set screw.
- (4) Turn ironworker on and inch down the punch to meet the die with the foot pedal jog control. Check to see that the punch is centered within the die.

- (5) Once punch is aligned with die, turn off power to machine; secure the die table to the ironworker base table by tightening the hardware provided.
- (6) Install the oversize punch stripper assembly to the ironworker frame with the hardware provided.
- (7) Swing the stripper bar into place allowing for minimal clearance between the top of the material to be punched and the bottom of the stripper and tighten the stripper bar bolts.

Safe operation

Observe the following guidelines when operating the oversize punch tooling.

Follow manufacturers punch and die clearance and tonnage recommendations as shown (figure 1, punch operation) in this manual.

Never exceed the capacities of the machine or tooling as described in the specifications or listed at the tooling station.

The thickness of the material you are punching should not exceed the diameter of the punch being used.

Check punch and die alignment after every tooling change.

Adjust the punch stripper supplied with your ironworker to allow for material position and material stripping.

Do not stack material to punch in the punching station.

Use 1-2 drops of oil at the punch to aid in stripping material from the punch as well as to extend the life of the punch tooling.

Punch complete holes only-partial holes will side load the punch tooling and could result in punch breakage and operator injury.

Use punch aids when working small items at the punch station.

Oversize punch tooling operation

- (1) Clear the punch station of any tools or debris prior to powering the machine on.
- (2) Place the material to be punched between the punch and die. Check to see that your material is spanning the stripper plate and that adequate material is available to safely position the material.
- (3) Clear your hands from the working area and depress the foot pedal to move the punch through the material and into the die.
- (4) When the punch is complete, release the foot pedal to automatically strip the material from the punch and return the punch to its neutral position.

OPTIONAL TOOLING-PIPE NOTCHER

Warnings

Pipe notcher tooling will provide a distortion and burr free, notch cut to mild steel pipe and tube stock. Common use of this tooling is in the fabrication of saddle connections for motorcycle and race car tube frame, tube fences etc. please review the capacity labels listed in the ironworker accessories specifications as well as positioned at the pipe notching station.

Setup

Pipe notch tooling fits within the open station of the machine. A pipe notch tooling assembly includes one push block, one top notcher die, one bottom notcher die and a die table. Pipe notcher tooling for the 100 ton deluxe and 120 ton ironworker also includes a slug chute. The top die is mounted within a spring loaded guide housing mounted to the die table. The bottom die attaches to the face of the guide housing and is machined with a saddle to aid in centering and guiding pipe sections into the die housing. The moving "center" of the ironworker, pushes on the top pipe notcher blade via the accessory push block. If ordered as a factory installed option, your pipe notcher assembly is setup for immediate operation.

Of ordered as an option, the open cavity of the machine must be cleared of any existing tooling, material or debris prior to tooling installation. To setup your pipe notching station please observe the following steps.

Turn off power to machine by depressing the red stop/off button or lockout upstream power at the main electrical panel.

Install the push block:

- (1) Remove all tooling and guarding from the open station.
- (2) Install the push block supplied with the pipe notcher assembly to the moving center of the ironworker. Secure the push block with bolts provided.

Install the pipe notcher assembly:

- (1) Place the pipe notcher assembly on the ironworker support table with the bottom die pointing away from the machine.
- (2) Loosely secure the table from the underside of the base with four 1/2" bolts and washers (privoded).
- (3) Check for push block and top die alignment by powering on the machine and slowly inching down the push block to meet the top die with the foot pedal. Power the machine off.
- (4) In the event that push block and top die are not aligned, simply loosen the bolts under the table allowing the table to be moved to center the push block centerline to the top blade. When aligned, tighten the table bolts to secure the table.
- (5) Power the machine on and jog the center down. The pipe dies will close or pass each other. The push block should not come in contact with the die housing.

Safe operation

Observe the following guidelines when operating the pipe notch tooling.

Never exceed the capacities of the machine or tooling as described in the ironworker specifications or listed at the tooling station.

Keep the pipe notch tooling clean. When dirt or metal chips assumulate, remove 5/16-15x1/2" limit screw located in the center at the rear of punch. Lift our punch holder and two springs. Clean holder with solvent or kerosene.

Check pipe notcher blade clearance and alignment at every tooling change, maintenance cycle or extended notcher operation. Maintain 0.010" clearance between notcher blades at all times. Failure to maintain clearance will damage blades and support pockets.

Do not stack material to cut in the pipe notcher station.

Perform complete notch operations only-partial notch cuts may jam the drop off side of the tooling and could result in breakage and operator injury.

Use notching aids when working with small items at the notcher station.

Pipe notcher operation

- (1) Clear the feed table of the pipe notcher station of any tools or debris prior to powering the machine on.
- (2) Turn machine on. The top notcher die will be in the neutral position. Push the material into the blade area. Position your material to the desired cut.
- (3) Clear your hands from the working area and depress the foot pedal to activate the pipe notcher station. When the cut is complete, release the foot pedal to automatically return the top notcher die to the neutral position.

OPTIONAL TOOLING-ROD SHEAR/MULTI-SHEAR

Warnings

"Bump-die" shear tooling is available for your ironworker. Rod shear or multi shear tooling will provide distortion and burr

free cuts to mild steel rod, square, bar and small angle stock as listed in the ironworker accessories specification.

Setup

“Bump-die” tooling and accessories fit within the punch station, open station or open tooling cavity of the machine. Verify recommended location per ironworker model below. “Bump-die” tooling consists of a housing which holds a stationary blade, a moving blade, return springs and a push block. The moving “center” of the ironworker, “Bumps” the top moving blade via the push block to shear the material. Of ordered as a factory installed option, your “bump-die” assembly is setup for immediate operation. If ordered as an option, the open or punch cavity of the machine must be cleared of any existing tooling, material or debris prior to tooling installation. To setup your rod shear or multi shear tooling please observe the following steps.

Identify install location:

25 ton	open station
40 ton	open station
50 ton	open station
55 ton	open or punch station
60 ton	punch station
65 ton	punch station or open cavity
75 ton	punch station
100 ton	open or punch station
100 ton deluxe	punch station
120 ton	open cavity

Install the bump-die assembly:

- (1) Remove all tooling and guarding from the appropriate open, punch or open cavity station.
- (2) Place the “bump-die” assembly on the ironworker support table with the push block in line with the moving center.
- (3) Loosely secure the table from the underside of the base with four 1/2” bolts and washers (provided).
- (4) Check for push block and moving center alignment by powering on the machine and slowly inching down the center to meet the push block with the foot pedal. Power the machine off.
- (5) In the event that the push block and top die are not aligned, simply loosen the bolts under the table allowing the bump-die to be moved to center the push block with the moving center. When aligned, tighten the table bolts to secure the table.
- (6) Power the machine on and jog the center down. The moving blade will close or bypass the fixed blade. The push block should not come in contact with the die housing.

Safe operation

Observe the following guidelines when operating any rod shear or multi shear bump-die tooling.

Never exceed the capacities of the machine or tooling as described in the ironworker specifications or listed at the tooling station.

Keep the tooling clean.

Check blade clearance and alignment at every tooling change, maintenance cycle or extended tooling operation. Maintain

0.010" clearance between blades at all times. Failure to maintain clearance will damage blades and support pockets.

Do not stack cut material.

Perform complete shearing operations only-partial cuts may jam the tooling and could result in breakage and operator injury.

Use shearing aids when working with small items at the rod shear or multi shear tooling station.

Rod shear/multi-shear operation

- (1) Clear the work area of any tools or debris prior to powering the machine on.
- (2) Turn the ironworker on and insert material through the tooling guard and into the blade area. Position your material for the desired cut.
- (3) Clear your hands from the working area and depress the foot pedal to activate the tooling station.
- (4) When the cut is complete, release the foot pedal to automatically return the tooling to the neutral position.

OPTIONAL TOOLING-PUNCH

Warnings

Your ironworker is capable of punching materials as listed in the ironworker specifications as well as described on the capacity labels positioned at the punch station.

Setup

241 punch tooling fits within the open or standard punch station of the machine. 241 punch tooling includes an oversize punch stripper, punch holder assembly, die table and wrench. Punch and dies are wearing parts and will need to be maintained or replaced over time. Refer to the maintenance manual for removal and replacement instructions. When installing 241 punch and die tooling please observe the following steps.

Turn off power to machine by depressing the red stop/off button or lockout upstream power at the main electrical panel.

Install the punch holder:

- (1) Clear any tooling or debris from the tooling installation site.
- (2) Secure the 241 punch holder to the operating center by first removing the stud from the holder. Place the holder to the operating center with the tapped hole positioned to the outside of the center. Install holder with two 1/2" SHCS bolts and tighten. Install stud to holder with four 3/8" SHCS bolts and tighten.

Install the die table:

- (1) Place the 241 die table and slug chute on the support table base and loosely install four 1/2" bolts (provided) through the underside of the support table into the 241 die table.
- (2) Install new oversize die and tighten set screw. If loading a shaped die, align the whistle spot with the set screw and tighten.
- (3) Install new 241 punch and tighten with spanner wrench. If using a shaped punch, align the locating keystone (not provided) of the punch with the corresponding slot with the punch stem assembly and tighten the punch nut with the wrench.
- (4) Check for punch and die alignment by powering up the machine and slowly down the punch to meet the die with the foot pedal. Check to see that the punch is centered in the die. Turn off power to machine.
- (5) In the event that the punch and die are not aligned, simply loosen the bolts under the table allowing the table to be

moved to center the die. When aligned, tighten the table bolts to secure the table.

- (6) Install and secure the 241 stripper bar to the ironworker frame allowing for minimal clearance between the top of the material to be punched and bottom of the stripper.

Safe operation

Observe the following guidelines when operating the 241 punch station.

Follow manufacturers punch and die clearance recommendations as shown (figure 1, punch operation) in this manual.

Never exceed the capacities of the machine or tooling as described in the ironworker specifications or listed at the tooling station.

The thickness of the material you are punching should not exceed the diameter of the punch being used.

Check punch and die alignment after every tooling change or extended punch operation.

Adjust the punch stripper supplied with your 241 tooling to allow for material positioning and material stripping.

Do not stack material to punch in the punching station.

Use one or two drops of oil at the punch to aid in stripping material from the punch as well as extend the life of the punch tooling.

Punch complete holes only – partial holes will side load the punch tooling and could result in punch breakage and operator injury.

Use punching aids when working with small items at the punch station.

241 punch operation

- (1) Clear the punch station of any tools or debris prior to power the machine on.
- (2) Turn the ironworker on and place the material to be punched between the punch and die. Adjust the punch stripper for minimum clearance between stripper plate and material. Check to see that your material is spanning the stripper plate and that adequate material is available beyond the stripper area to safely position the material.
- (3) Clear your hands from the working area and depress the foot pedal to move the punch through the material and into the die. When the punch is complete, release the foot pedal to automatically strip the material from the punch and return the punch to its neutral position.

4. TROUBLE SHOOTING

Problem	Solution
Machine runs but will not cycle	<ul style="list-style-type: none"> Check rotation of motor Check correct amp/voltage to machine Check drive key is in place Check foot pedal cable obstruction Check power supply for green light Check electric foot pedal for obstruction Check proximity switches
Machine cycles down but will not return to neutral position	<ul style="list-style-type: none"> Check rotation of motor Check return spring at valve Check foot pedal linkage
Machine turns off after short time in use	<ul style="list-style-type: none"> Check correct amp/voltage to machine
Electric stroke option malfunction	<ul style="list-style-type: none"> Check correct amp/voltage to machine Check fuse at starter box Check fuse at transformer box Check for loose microswitch connections Check for damaged microswitch
Distortion of small angle shear cut	<ul style="list-style-type: none"> Check radius orientation of blade
Brass shaving below gib-pins and slides	<ul style="list-style-type: none"> Brass shaving are common and expected during the break-in period and after blade maintenance
Hydraulic feel hot after operation	<ul style="list-style-type: none"> Hydraulic syste operates within the 160-190 degree range
Shear blades or punch and die do not close completely	<ul style="list-style-type: none"> Check for notch tooling obstruction Check for brake tooling obstruction
Punch and die misalignment	<ul style="list-style-type: none"> Check that punch is tight in holder Check that punch stud is secure in block Check for blade alignment
Machine will not complete punch or shear operation	<ul style="list-style-type: none"> Check tonnage of machine rating against steel hardness and thickness Check for work station obstruction Check foot pedal linkage Check hydraulic fluid level Check slides for wear or obstruction Check electric stroke control option Check die support plate
Hydraulic oil overflow/foaming at breather cap	<ul style="list-style-type: none"> Check hydraulic fluid level Check for loose hose coupling

6. Drawing

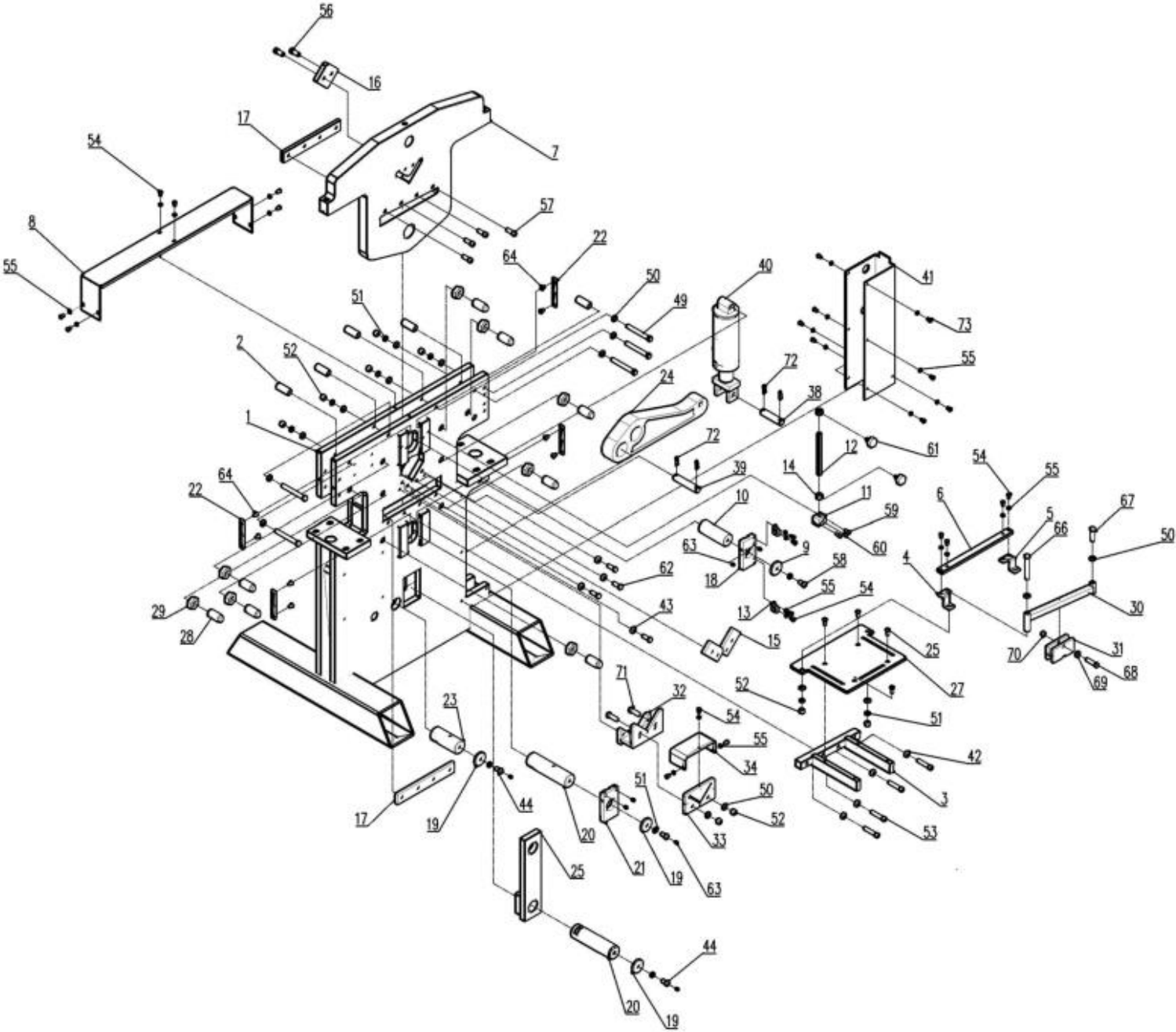

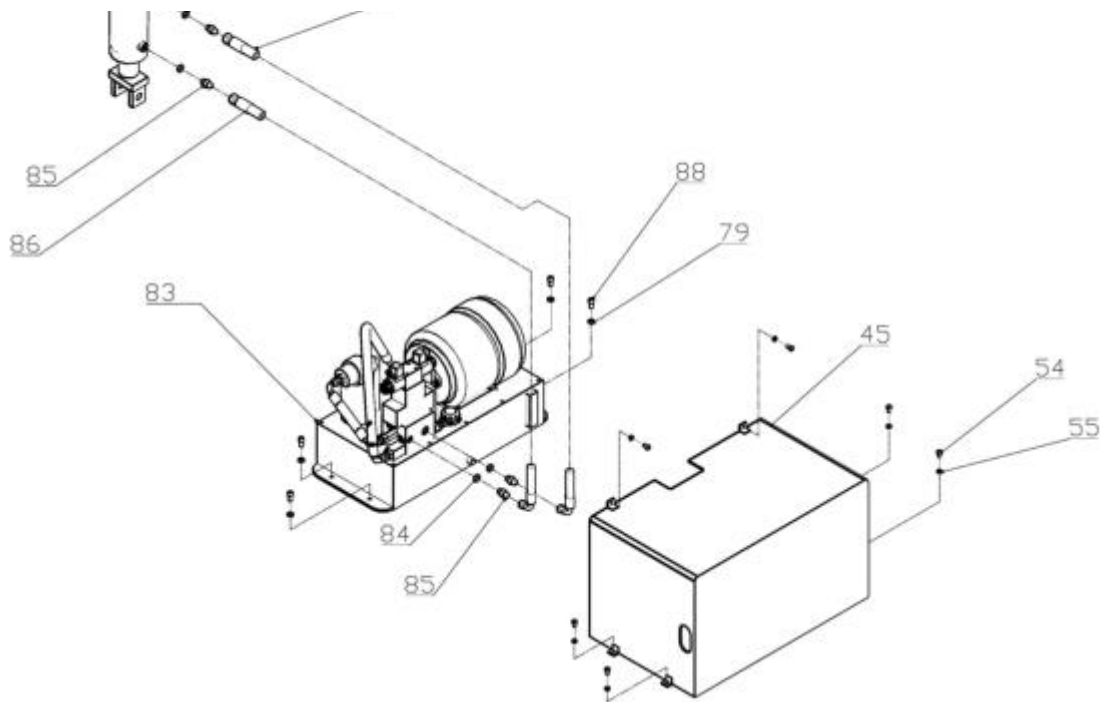
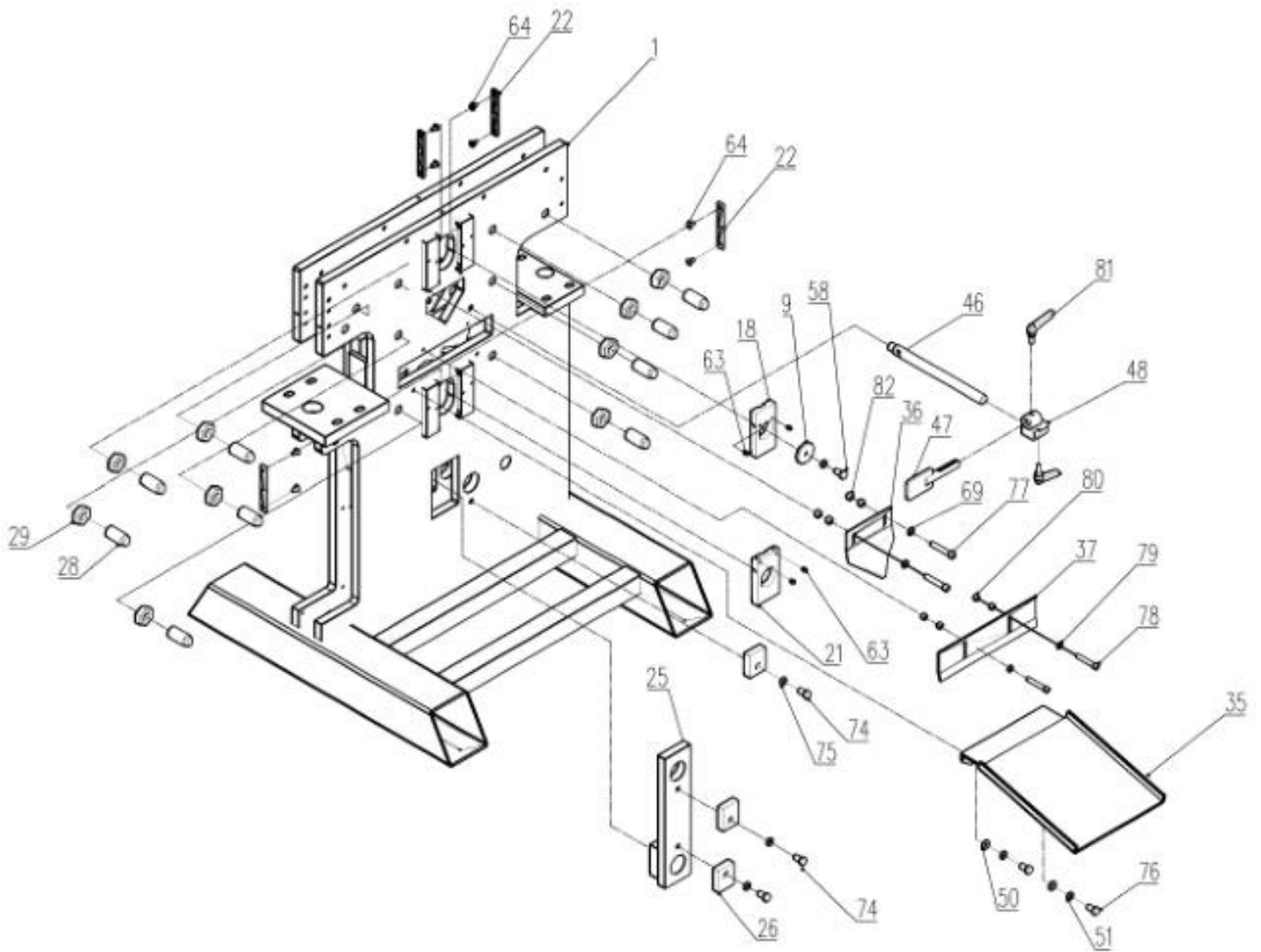

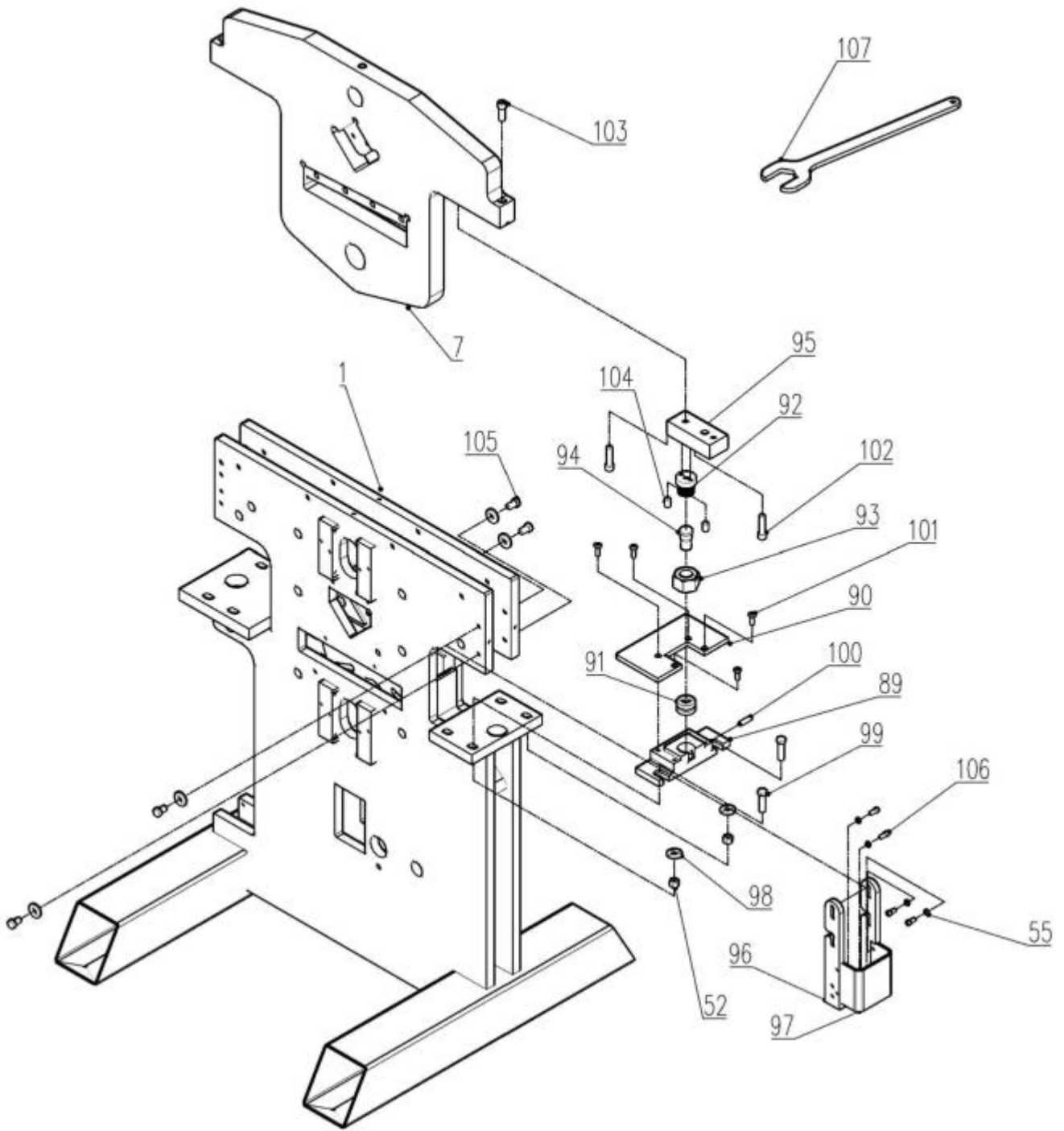

PART LIST

Item	Description	Qty	Item	Description	Qty
1	Frame	1	31	slide block	1
2	Bushing	5	32	Bracket for angle shear	1
3	Support	1	33	Fixed plate	1
4	Left stand	1	34	Guard	1
5	Right stand	1	35	Material plate	1
6	Clarity guard	1	36	V plate	1
7	Slide board	1	37	Long back plate	1
8	Top cover	1	38	Long pin shaft	1
9	Ring	2	39	Short pin shaft	1
10	Upper shaft	1	40	Cylinder	1
11	Bracket	1	41	Cylinder guard	1
12	Adjustable lead screw	1	42	Big washer	4
13	Support	2	43	Small washer	4
14	Bushing	2	44	Bolt	3
15	Lower blade	1	45	Hydraulic system guard	1
16	Upper blade	1	46	Rod	1
17	Shearing blade	2	47	Block	1
18	Upper slide block	2	48	Lock Joint	1
19	Ring	3	49	Bolt	5
20	Long shaft	2	50	Washer	18
21	Lower slide block	2	51	Spring washer	13
22	Panel	8	52	Nut	11
23	Short shaft	1	53	Bolt	4
24	Lever	1	54	Bolt	23
25	Link	1	55	Washer	39
26	Block	3	56	Bolt	2
27	Table	1	57	Bolt	4
28	Bolt	18	58	Bolt	2
29	Nut	18	59	Bolt	2
30	Hold down rod	1	60	Bolt	1

Item	Description	Qty	Item	Description	Qty
61	Star knob	2	85	Connector	4
62	Bolt	4	86	Oil hose	1
63	Oil cup	11	87	Oil hose	1
64	Bolt	16	88	Bolt	4
65	Bolt	4	89	Base	1
66	Bolt	1	90	Table	1
67	Bolt	1	91	Die	1
68	Bolt	1	92	Punch seat	1
69	Washer	4	93	Nut	1
70	Nut	1	94	Punch	1
71	Bolt	2	95	Top seat	1
72		4	96	Guard I	1
73	Bolt	8	97	Guard	1
74	Bolt	3	98	Washer	6
75	Washer	3	99	Bolt	2
76	Bolt	2	100	Bolt	1
77	Bolt	2	101	Bolt	4
78	Bolt	2	102	Bolt	2
79	Washer	6	103	Bolt	1
80	Nut	4	104	Pin	2
81	Tighten handle	2	105	Bolt	4
82	Nut	4	106	Bolt	4
83	Hydraulic system	1	107	Wrench	1
84	Washer	4			

Note: This manual is only for your reference. Owing to the continuous improvement of the machine, changes may be made at any time without obligation on notice. Please note the local voltage for operating this machine.