

# HYDRAULIC BENDING MACHINE

MODEL: HW1220X3.5, HW1830X3.5

HW2440X3.5, HW3050X3.5



***OPERATION MANUAL***

# Table of Contents

I. Structure and Use-----	2
II. Specification -----	2
III. Transportation and Installation-----	2-3
IV. Safety inspection and Safety rules during and/or before operation-----	3-4
V. Machine adjustment-----	4-6
<b>VI. Lubrication-----</b>	<b>7</b>
<b>VII. How to use back gauge-----</b>	<b>8</b>
<b>VIII. Hydraulic diagram and electric diagram-----</b>	<b>9-11</b>
<b>IX. Operation-----</b>	<b>12-13</b>
<b>X. Troubleshooting-----</b>	<b>14</b>
<b>XI. Drawing and packing list-----</b>	<b>15-23</b>

## I. Structure and Use

This machine is driven by hydraulic, smooth transmission, body, clamping beam and bending leaf adopts steel plate welded structure, with high intensity, good appearance, compact, safe and reliable. This machine is suitable for the sheet metal processing plants, electrical protection, automobile manufacturing and other thin sheet metal bending processing

## II. Specification

Model	HBB-0410	HBB-0610	HBB-0810	HBB-1010
Max. bending thickness(mm)	3.5	3.5	3.5	3.5
Max. bending width(mm)	1220	1830	2440	3050
Angle(°)	0 ~135	0 ~135	0 ~135	0 ~135
Hydraulic cylinder stroke(mm)	400	400	400	400
Hydraulic cylinder pressure (MP)	15	15	15	15
Hydraulic cylinder speed(mm/s)	50-58	50-85	50-85	50-75
Motor working pressure (Mp)	12	12	9-13	16
Motor Speed range(rpm)	<30	<30	<30	<30
Motor power(kW)	3.7	3.7	5.5	7.5
N.W./G.W.	-----	2170/2300	2850/3000	3400/3600
Packing size(cm)	205x102x170	265X102X170	325X102X170	390X102X170

## III. Transportation and Installation

Crane or forklift is recommended

To move the machine, it must slow down, especially pay attention.

The machine is lifted by crane or removed by forklift after the removal of pallet packing.

The length of fork for forklift should be at least 100mm over the center of machine.

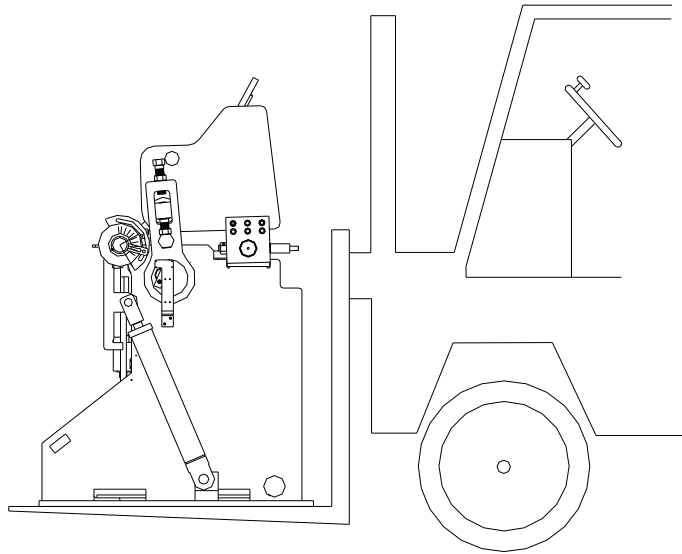

**2、 Installation:** When installing machine should be installed in a horizontal on the bottom of foundation, adjust the machine table to the horizontal lateral are within 0.3 mm / 1000 mm. According to the fuselage on one side of the machine to four, a total of eight anchor hole, completes the corresponding foundation, through the anchor bolt fix the machine tool based on the level.

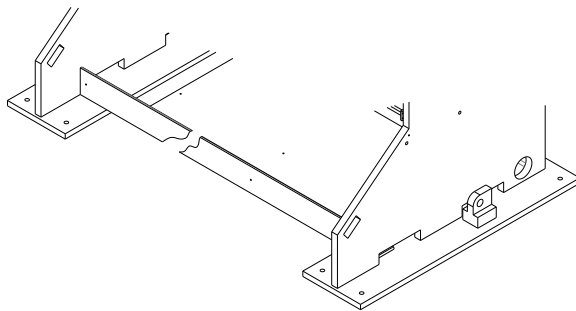

#### **IV. Safety inspection and Safety rules during and/or before operation**

**To ensure safety, it is necessary to do the following inspections for this machine after installation.**

Check if the transportation procedure has influenced the accuracy and functions of the machine.

Check if the foundation of the machine is appropriate.

Check if the machine's main power switch should have earth wiring connected.

Use the multimeter to check the stability of the three-phase voltage

Check if the control panel function and push button are functioning

Check emergency stop function.

Check if safety protection accessories are functioning well

Check if other accessories, including hydraulic and pneumatic ones, are connected well (including transformer etc.)

Check if the oil amount indicator and air pressure indicator are normal.

Make sure no obstacle is around machine and control system.

Make sure no personnel are in dangerous area.

Tools and any unnecessary items are not allowed on the machine, moving parts, or similar locations.

Before pressing/switching any button/switch always confirm that the button/switch is the correct one and never

touch a switch accidentally. Malfunction and potential danger might result.

Do not operate when wearing gloves or loose clothing. Malfunction and potential danger might result.

Do not touch switches with wet hands, an electric shock could occur.

If a work requires two or more operators, the cooperation among each operator must be well organized, every step of each operator should be clarified to avoid potential danger.

Tools should be consisting with the machine's specifications, such as dimensions, weight and types. Grip workpieces carefully to minimize movement and vibration between workpieces. Too much movement/vibration might result in injuries of personnel, or damage the machine or workpiece.

Stop the machine before replacing workpiece, and reserve sufficient distance between workpiece and machine. Safety for the electrical connection/disconnection

**Electrical connection:**

A cable with four wires is supplied to connect your machine into the 3 phase power supply. The exact power source voltage, frequency, and number of phase shall be checked according to the installation diagram and circuit diagram. The correct direction of spindle should be checked after connecting.

**Electrical disconnection:**

Be sure to disconnect this machine from power source, when you want to stop the job for maintenance or adjustment.

**Grounding**

The grounding of this model is carried out by connecting the yellow/green terminal of supply cable to the grounding terminal of power source. Be sure to ground your machine before connecting machine to power source in any situation.

**Warning!**

Do not disconnect grounding terminal before disconnecting power source!

Description for the safety function of this machine

The following safety functions are equipped with this machine. Be sure to check and ensure the correct function before you start to operate your machine:

**The emergency stop device:**

The machine is designed to be immediately stopped under emergency situation. As soon as this device is actuated, any movement will be stopped in a short time after the actuation of emergency button. Be sure to check that machine action will stop immediately after this button is pressed and will not cause any action when this button is disengaged.

## V. Machine adjustment

### CLEARANCE CHART

Before operation, please use the following formula to calculate & adjust the gap between the punch & die according to the thickness of the work piece

For the following, A=material X2, for example, if you want to process 3.5mm thickness material, the A=3.5X2=7mm.

B=thickness of material -0.5~2mm. For example, if the thickness of the material is 2.0mm, the B=1.0mm. If the thickness of the material is 3.5mm, B=2.5MM

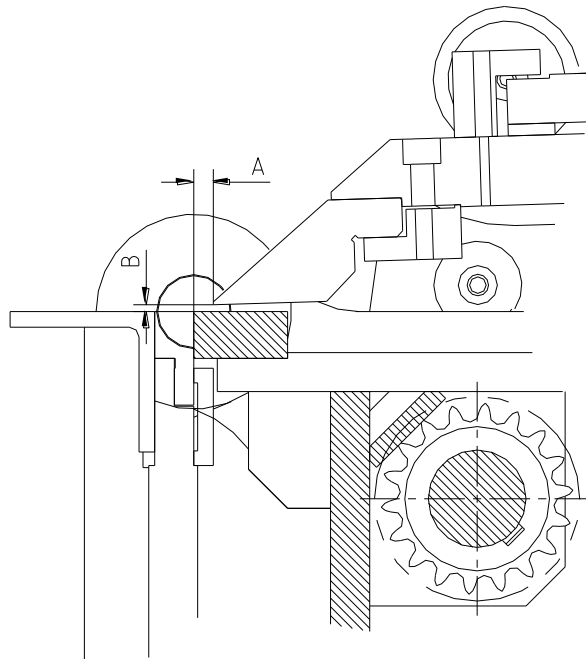

How to adjust A and B, please pay attention to the following.

- 1) Adjust A: A could be adjusted through No.3 hand wheel left and right to adjust A.
- 2) Adjust B: Loose No 2 after adjust to the right pressure then tight No.1

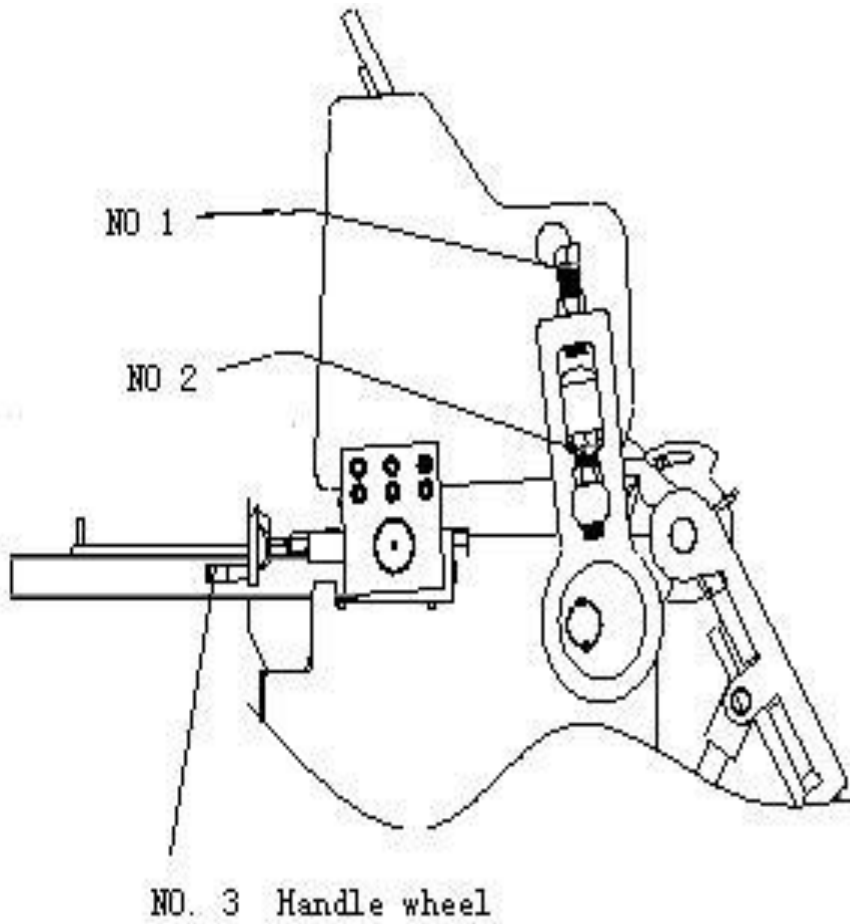

### TABLE CROWNING COMPENSATION

If the angles of work-piece two sides are both on 90 degree, but middle side only 89 degree, Micro adjusting screws at bending left and bottom beam for compensate the middle has the same angle.

- 1) Open the top beam, and then turn off the machine power
- 2) Tight screws A-G at upper beam and folding leaf, and make screw tight following different work-piece crowing situation.

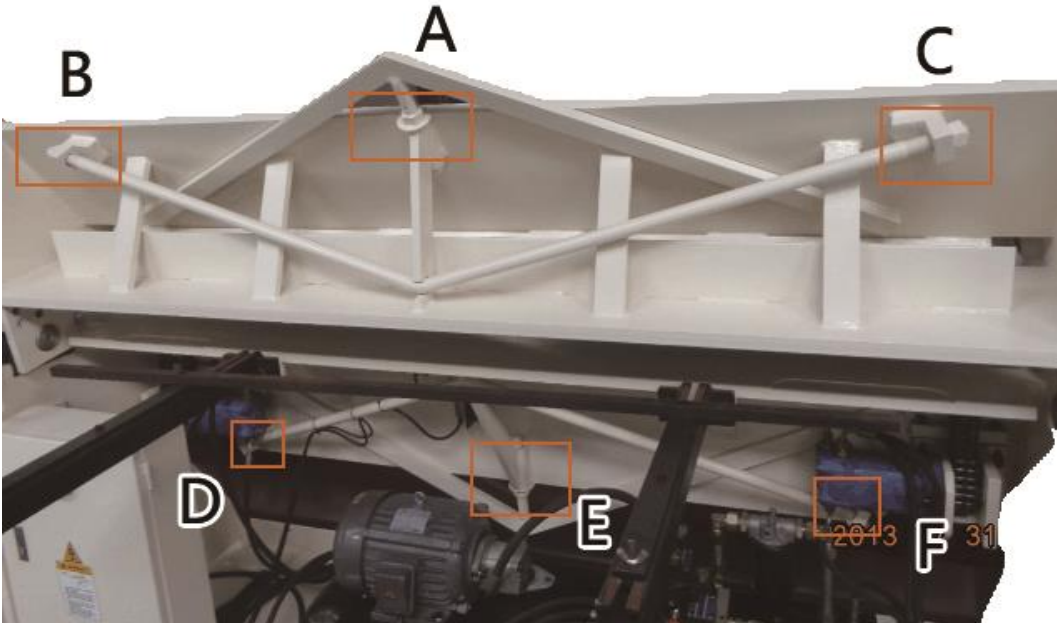

# VI. Lubrication

Please lubricate the following picture ① ② ③ ④ has four times a day.

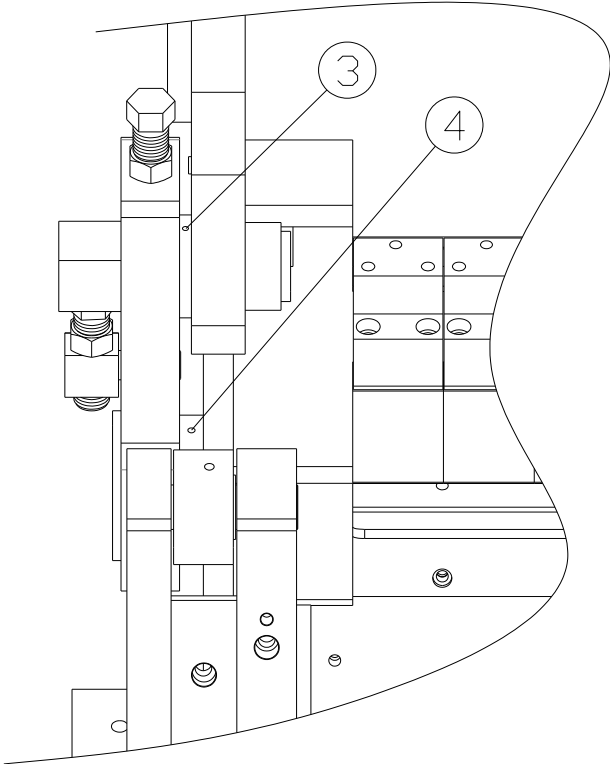
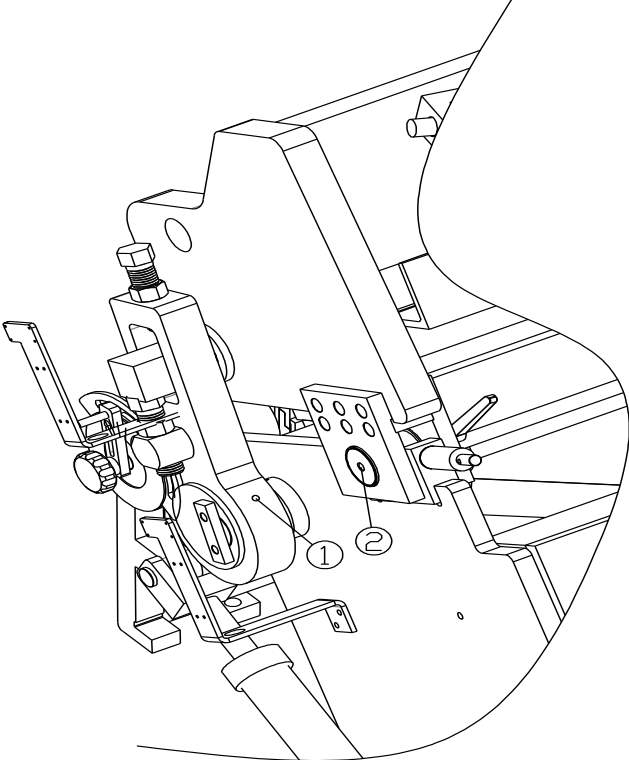



## VII. How to use back gauge

This machine is manual back gauge, before first time use, please move the back gauge plate to the down blade tightly. Back gauge fixed on the body of the machine through screw 1 and 2, back gauge square bar (6) fixed on back gauge through screw 3.

Adjust the distance of back gauge: Loosen the butterfly nut (4) and back gauge plate fixed (5), forwarder and back warder the back gauge square bar (6) to adjust the distance of the back gauge. Then tightly the screw (4)

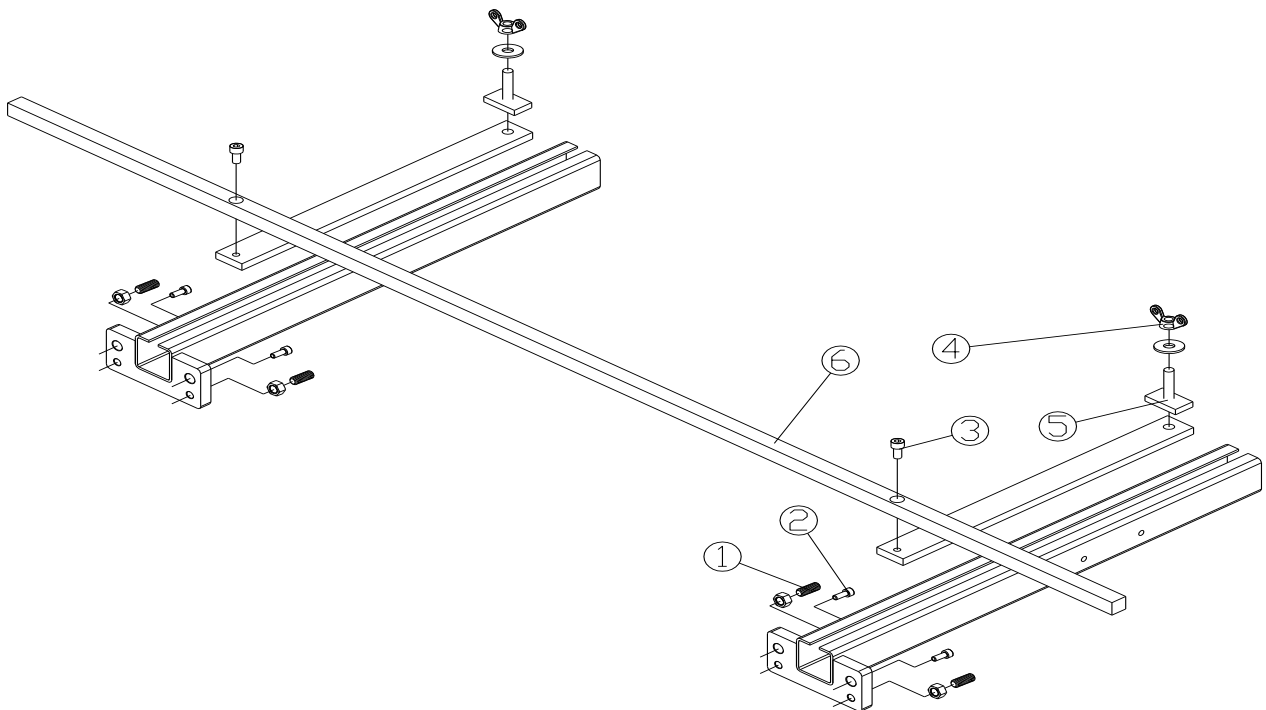
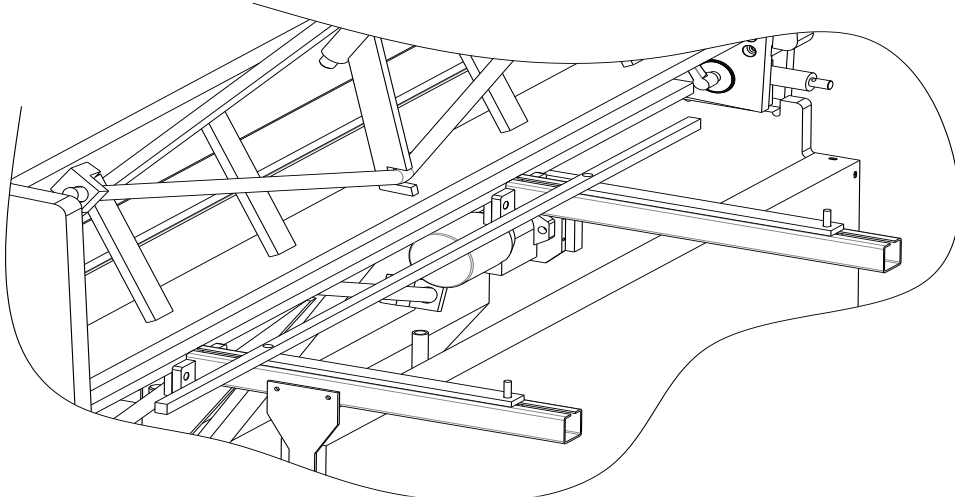

## VIII、Hydraulic diagram

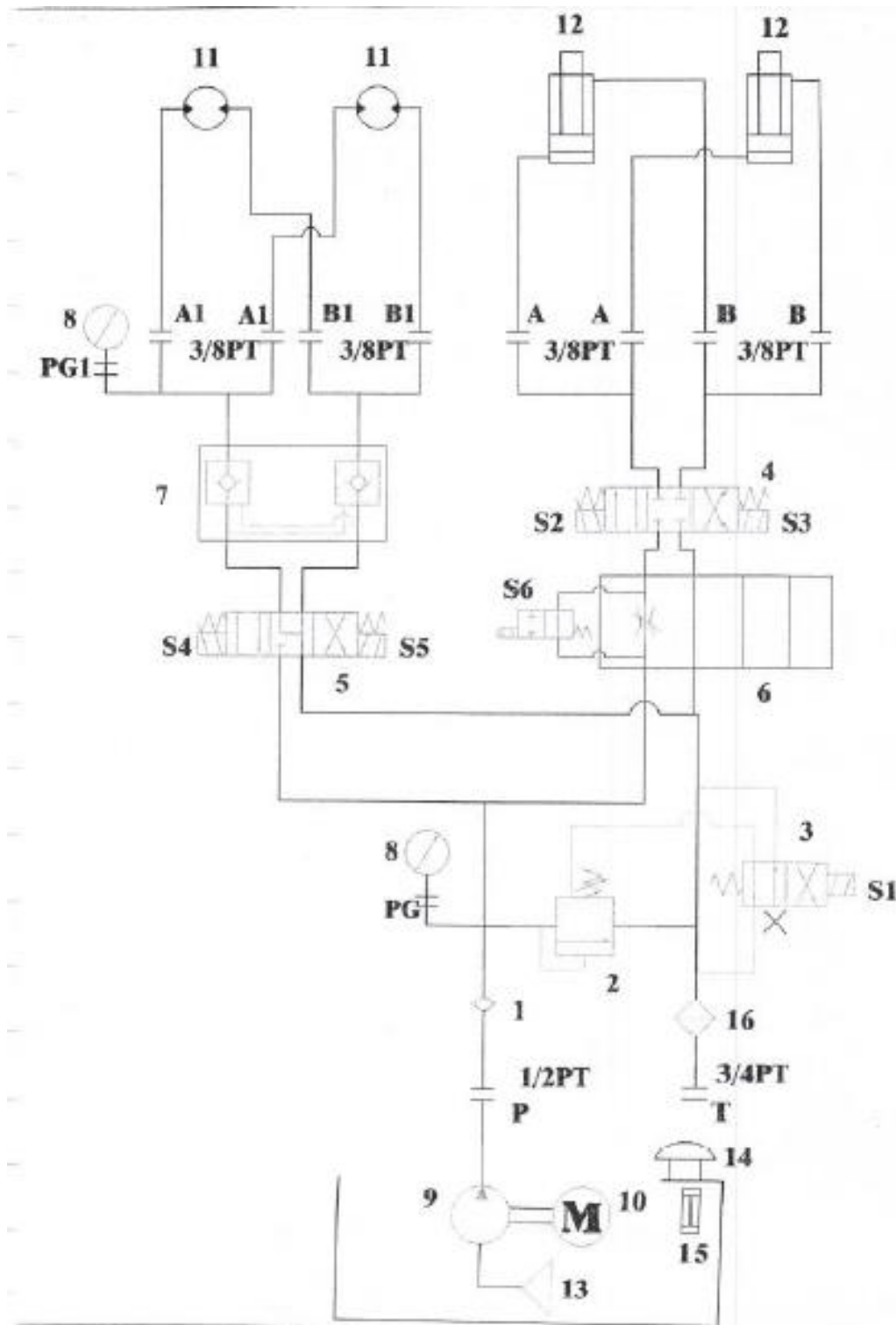

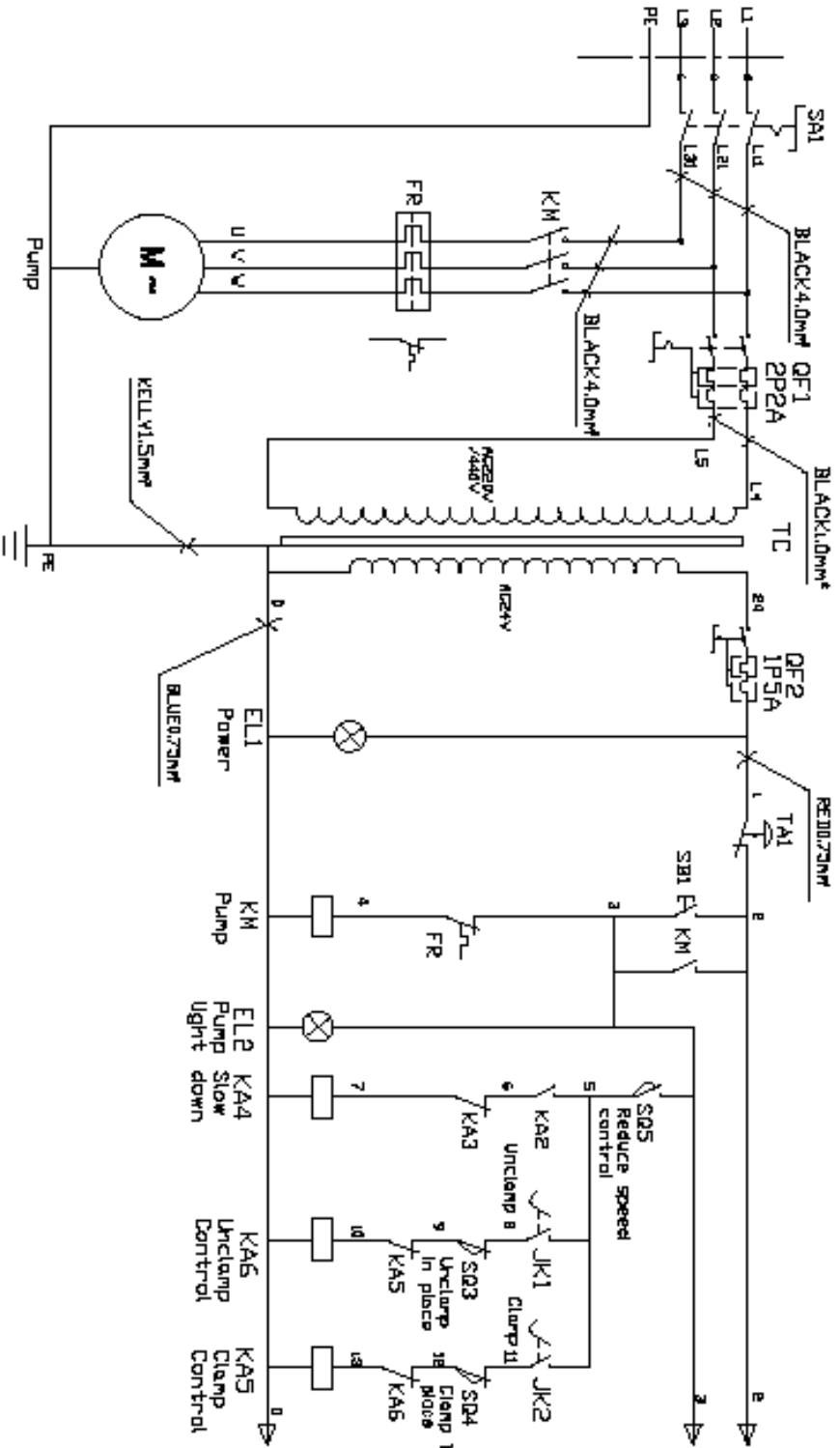

			DISARM NO.
	HYUNDAI/DAEWOO	DAEWOO	
		CHICKET	
CIRCUIT DIAGRAM 1			

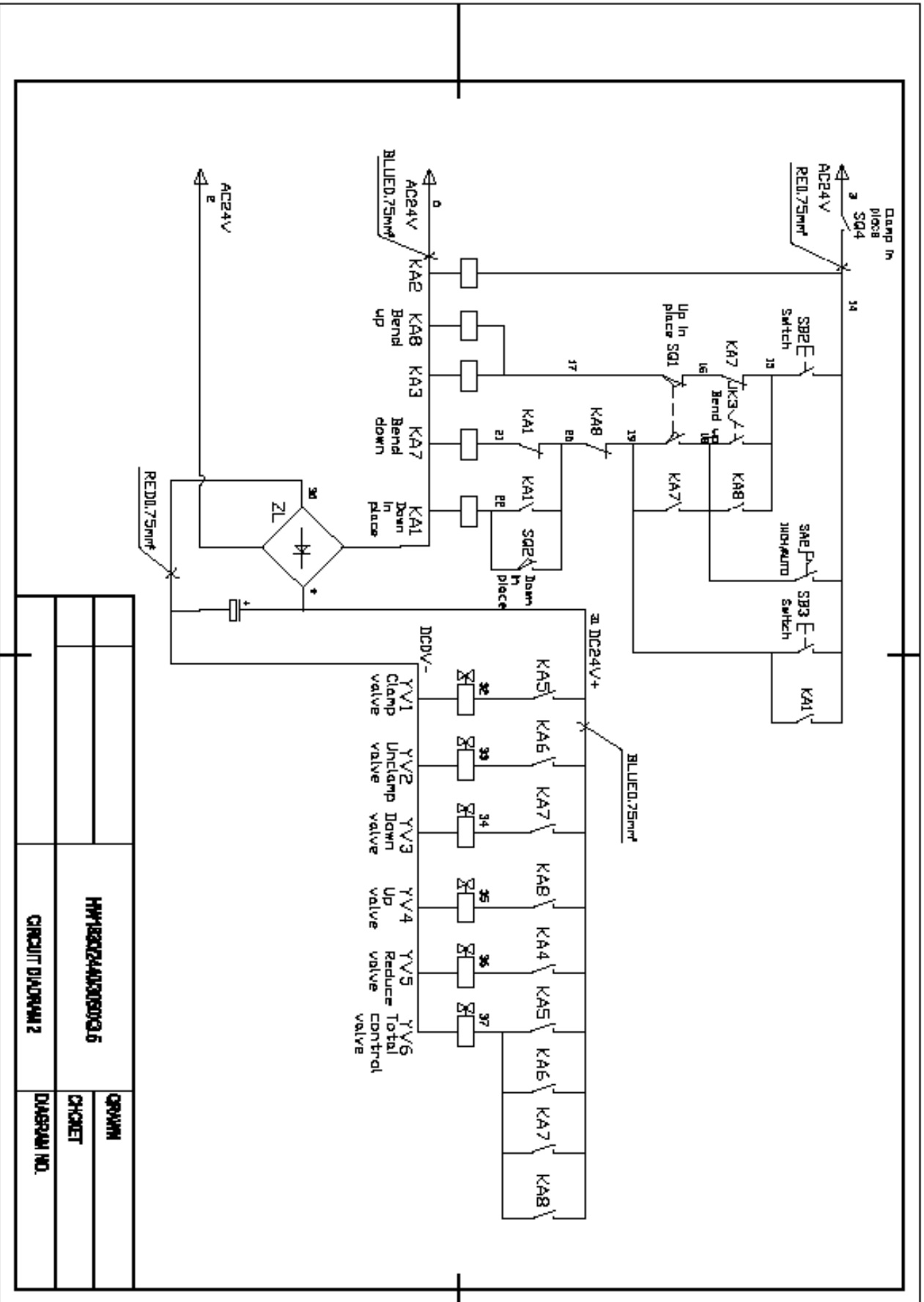

## IX.Operation

1) Turn the Switch on the electric box to "ON"



2) then power light ,clockwise E.STOP RESET and press pump start



3) Angle set: Anticlockwise the following circled handle and adjust the bending angle you need, then clockwise the handle, the bending angle is 0-135° .

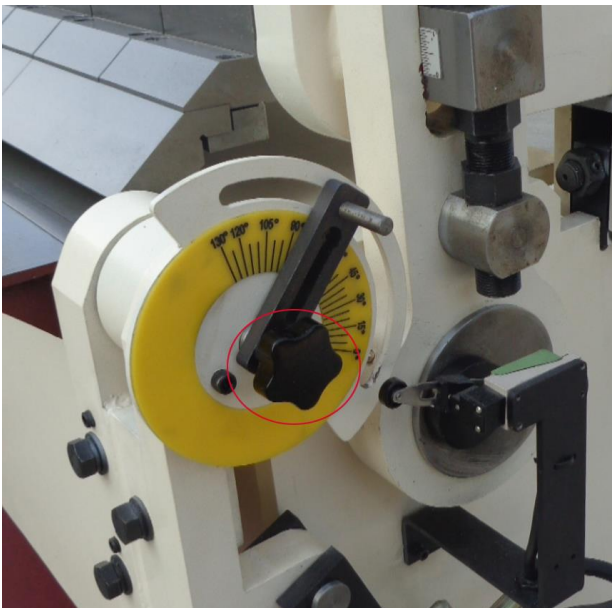

This machine has two working ways, one is for Auto, the other is inch.

#### 4)-1 Under inch working way.

Touch unclamp,the head will up,please put the material on the working table,then touch clamp.



Press the following circled button to bend position,the bending leaf will up and bend,after bending put the circled button to release position,the bending leaf will down and loose.



#### 4)-2 Under Auto working way.

Touch unclamp, the head will up, please put the material on the working table and touch clamp, then touch bend, the bending leaf will bend up and down by itself.



## X. Troubleshooting

<i>Trouble</i>	<i>Possible cause</i>	<i>Remedy</i>
Hydraulic cylinder crawling	Hydraulic or pipe has air	Start the hydraulic system and forth several times to the maximum stroke, forced exclusion of air; seal the pipeline and system.
	Somewhere a negative pressure in the hydraulic cylinder	Locate a negative pressure at the hydraulic cylinder and sealed, then exhaust the air.
Leakage of the hydraulic cylinder	Ring seal too tight	Adjustment ring, so as not to loose not tight, to ensure that the rod can be pulled back and forth by hand.
	Cylinder wall or piston surface strain, badly worn or local corrosion	Boring the cylinder bore, the piston reassignment
Leakage of the hydraulic cylinder	Cylinder bore and piston with the gap due to wear resulting in increased tolerance, rod surface damage	Repair rod damage
	Seal the edges injury or aging	Replace the seals
	Pipe joint is not seal tightly	Replace the seals
	Hydraulic cover is not seal tightly	Check the seal contact surface machining accuracy and aging, be replaced or repaired.
Sound and noise	Due to poor exhaust air temperature adiabatic compression cause local damage seals	Inspect the exhaust system, or additional exhaust, timely exhaust.
	1) hydraulic cylinder has air 2) Cylinder rod lack oil	1) Slow movement of the piston several times, each time went to the top, to exclude gas tank, you can eliminate this serious noise, but also to prevent seals burns. 2) cylinder rod oil can also cause less noise, this time should be oiled at the pole.

# XI. Drawing and packing list

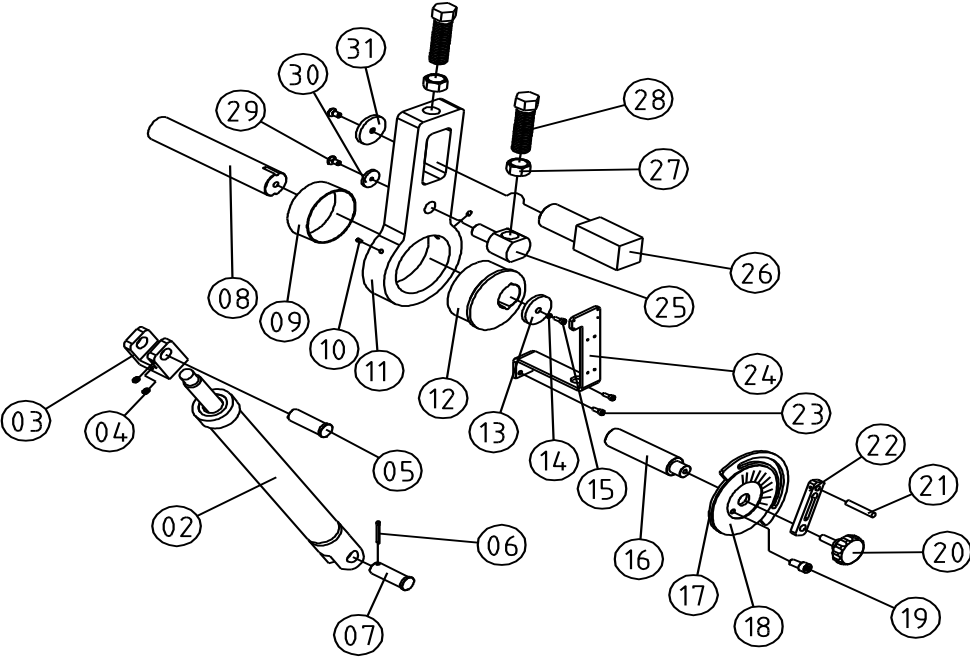



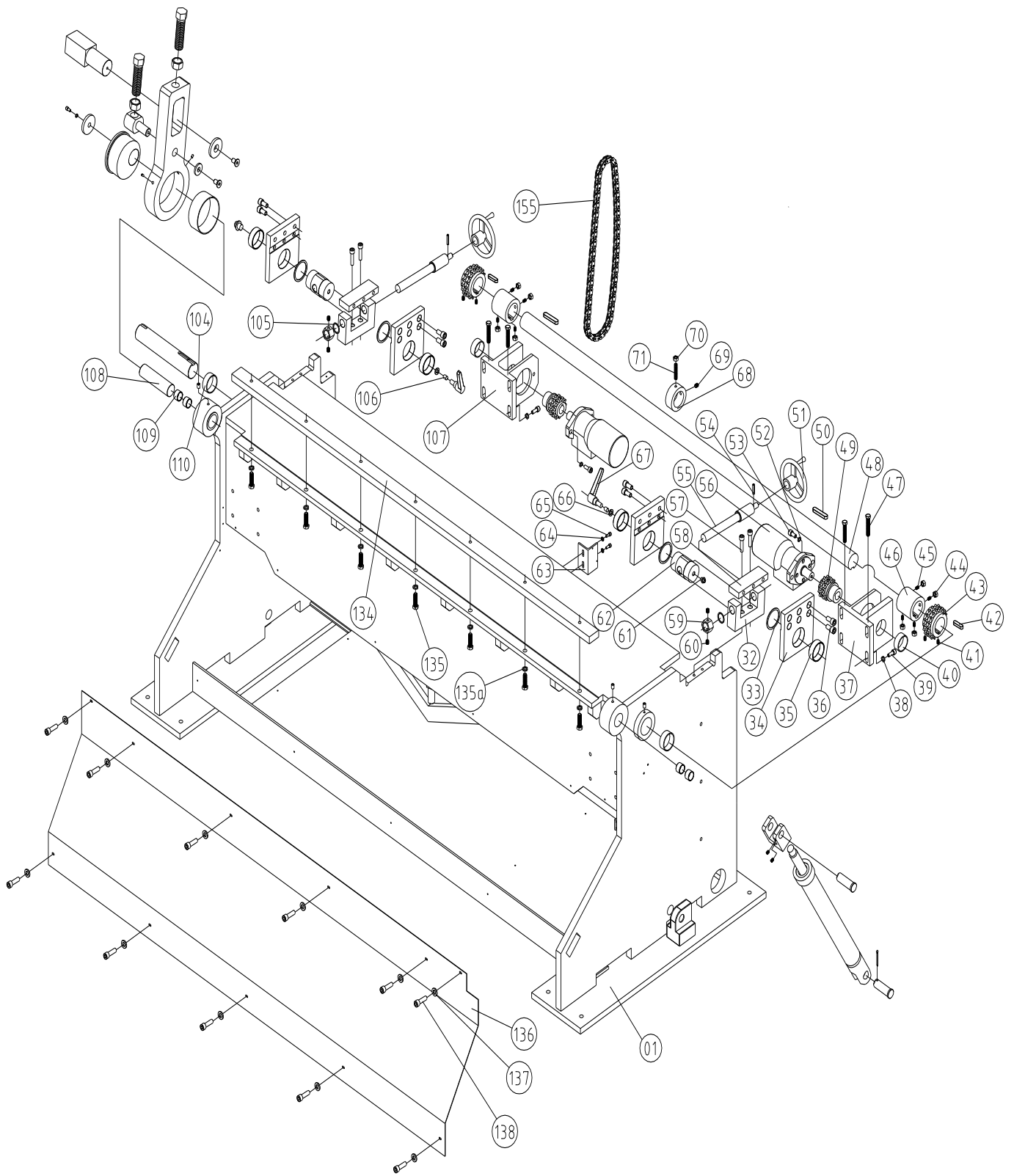

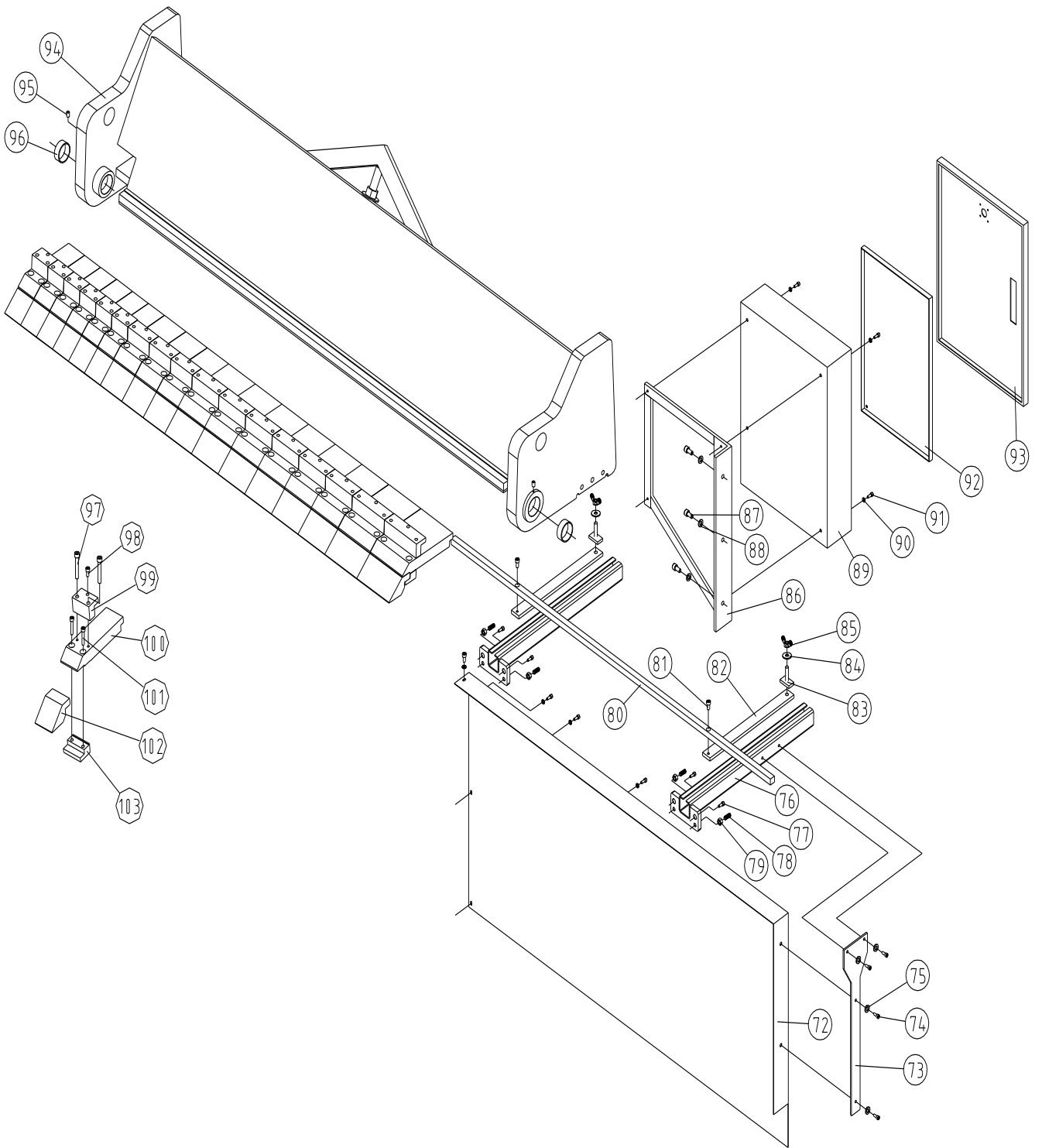

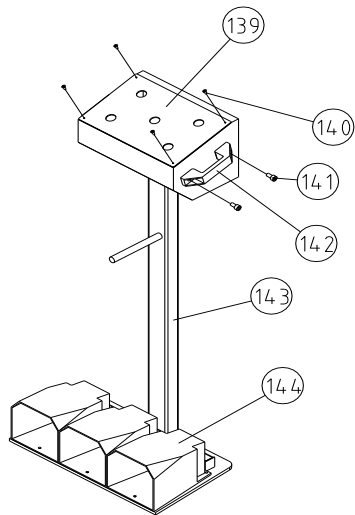
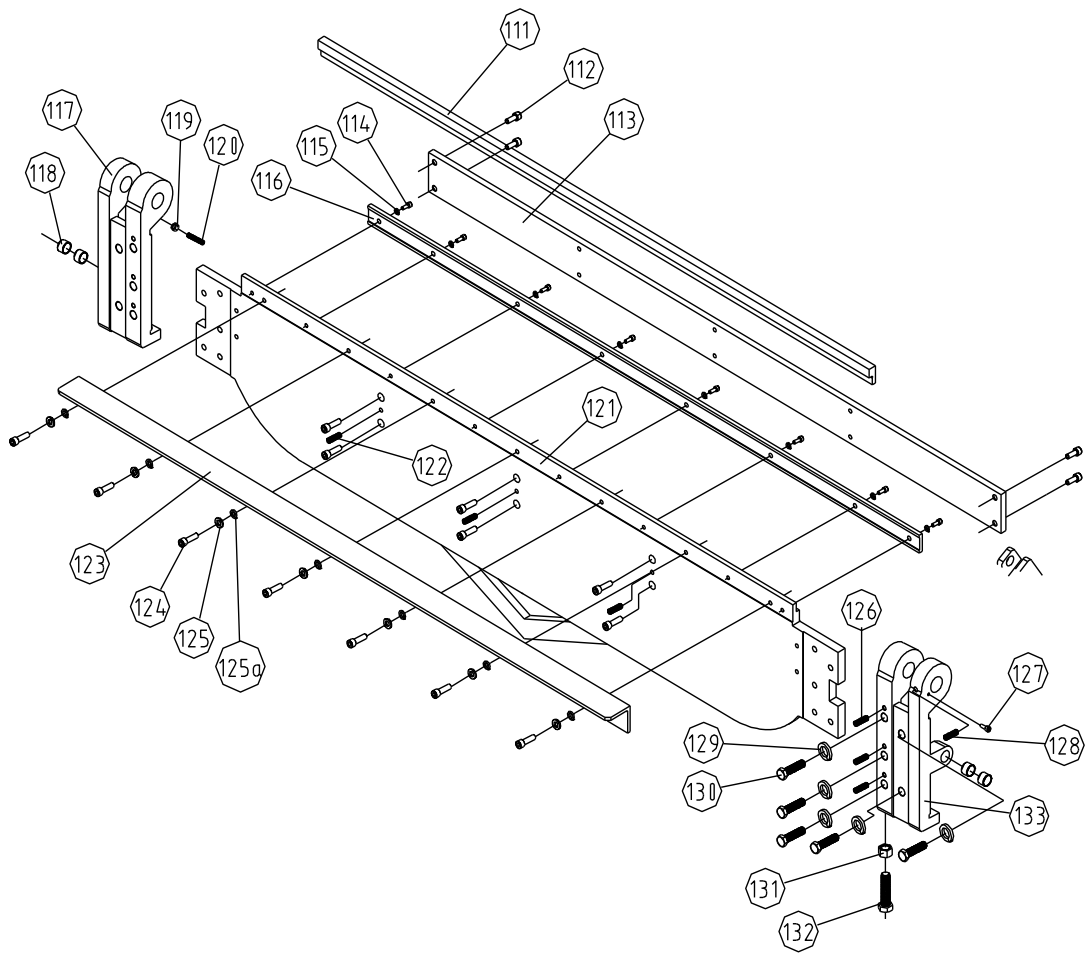

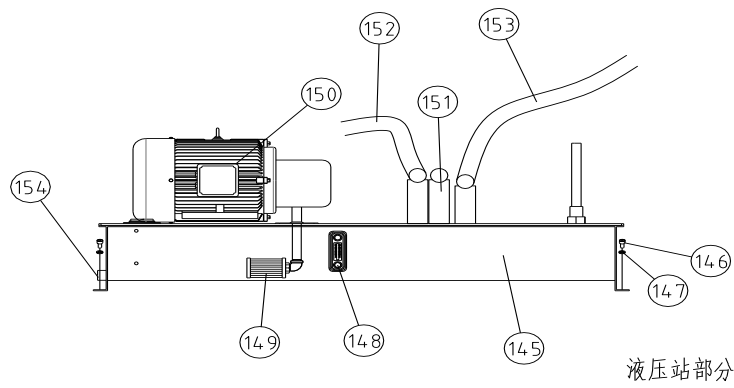

No.	Desc.		Q'ty	Note
1	Body		1	
2	Hydraulic Cylinder		2	2pcs different
3	Connecting plate on hydraulic cylinder		2	
4	Six pyramid end screw set	M8X12	4	
5	Fixed upper pole on hydraulic cylinder		2	
6	cotter	4X40	2	
7	Fixed bottom pole on hydraulic cylinder		2	
8	eccentric disk shaft		2	
9	bush	12050	2	SF-1
10	oil cup	8	4	
11	Eccentric disc holder		2	
12	Eccentric disk		2	
13	Eccentric disk fixed plate		2	
14	Spring washer	12	2	
15	hexagon socket cap screws	M12X35	2	
16	Leaf beam right rotation shaft		1	
17	Angle plate		1	
18	Angle plate		1	
19	hexagon socket cap screws	M8X40	1	
20	handle	M10X30	1	
21	Round pin	10X60	1	
22	Angle rotation boards		1	
23	hexagon socket cap screws	M6X16	2	
24	Emergency stop stand		1	

25	Bolt seat		2	
26	Head frame shaft		2	
27	Hex nut		4	
28	Hex screw		4	
29	Hexagon socket countersunk head screws	M10X25	4	
30	cover		2	
31	cover		2	
32	U-block		2	
33	Spacer		4	
34	Side plate of U-block		4	
35	Bush	5520	4	SF-1
36	Hex cylinder head screw	M12X25	24	
37	Right motor seat		1	
38	Spring washer	12	8	
39	Hex cylinder head screw	M12X40	8	
40	Bush	4520	2	SF-1
41	Hexagon socket countersunk head screws	M8X12	4	
42	key	12X45	2	
43	Large chain wheel		2	
44	Screw	M10	8	
45	Inner hexagon socket set screw	M10X20	8	
46	Driven sleeve		2	
47	Hex bolt	M10X65	4	
48	Driven shaft		1	
49	Small chain wheel		2	
50	Key	14X70	2	
51	Handle wheel	Φ16X125	2	
52	Spring washer	12	4	
53	Hex cylinder head screw	M12X40	4	
54	Spring pin	6X32	2	
55	Lead screw		2	
56	motor		2	
57	Hex cylinder head screw	M10X40	4	
58	Plate		2	
59	Nut		2	
60	Inner hexagon socket set screw	M10X40	4	
61	Oil cup	M8X1	2	
62	shaft		2	
63	Emergency seat		2	
64	Flat washer	6	4	
65	Hex cylinder head screw	M6X16	4	

66	Flat washer	12	2	
67	Adjustable handle	M12X25	2	
68	Touch off cover		1	
69	Inner hexagon socket set screw	M10X12	1	
70	Nut	M10	1	
71	Hex. socker	M10X50	1	
72	Back liner insert		1	
73	tailgate stents		1	
74	hexagon socket cap screws	M6X16	8	
75	flat gasket	6	8	
76	Keep-off stents		2	
77	hexagon socket cap screws	M12X25	4	
78	Allen flat end set screws	M10X25	4	
79	nut	M10	4	
80	Keep-off square bar		1	
81	hexagon socket cap screws	M8X16	2	
82	striker plate		2	
83	Keep-off square bar fixing parts		2	
84	big washer	10	2	
85	butterfly nut	M10	2	
86	Electric box connection frame		1	
87	hexagon socket cap screws	M10X20	3	
88	flat washer	10	3	
89	Electrical box		1	
90	flat washer	6	4	
91	hexagon socket cap screws	M6X16	4	
92	Electric plate		1	
93	Electric box door		1	
94	Top rack		1	
95	Oil cup	M8X1	2	
96	bush	5020	4	SF-1
97	hexagon socket cap screws	M10X65	34	
98	hexagon socket cap screws	M12X25	17	
99	Upper blade pressure block		1set	
100	Lower blade		1set	
101	hexagon socket cap screws	M12X50	34	
102	Upper blade		1set	
103	Lower blade pressure block		1set	
104	Oil cup	M8X1	2	
105	Copper dash		4	
106	Nylon pressure block		2	

107	Left motor seat		1	
108	folding fan left shaft		1	
109	bush	3820	4	
110	bush	5020	2	SF-1
111	Bending plate banners		1	
112	hexagon socket cap screws	M12X40	10	
113	Bending boy reinforcing plate		1	
114	Hex bolt thread	M10X25	8	
115	standard spring washer	10	8	
116	Back bending plate		1	
117	Left connecting		1	
118	bush	3820	4	SF-1
119	nut	M10	1	
120	Hex bolt thread	M10X50	1	
121	Bending body		1	
122	Hex bolt thread	M12X40	3	
123	knife edge angle iron		1	
124	Hex bolt thread	M12X30	7	
125	Flat washer	12	7	
125a	standard spring washer	12	7	
126	flat end set screws	M12X40	6	
127	hexagon socket cap screws	M8X40	1	
128	Inner hexagon socket set screw	M12X35	2	
129	standard spring washer	16	10	
130	Hex bolt thread	M16X65	10	
131	nut	M20	2	
132	Hex bolt thread	M20X75	2	
133	Right connecting		1	
134	Press block		1	
135	Hex bolt thread	M12X40	7	
135a	standard spring washer	12	7	
136	Front guard		1	
137	Flat washer	6	11	
138	hexagon socket cap screws	M6X16	11	
139	plate		1	
140	cross recess pan head screw	M4X8	4	
141	hexagon socket cap screws	M8X16	4	
142	carrying handle		2	
143	Operations support		1	
144	foot pedal		3	
145	oil cylinder		1	

146	hexagon socket cap screws	M6X16	4	
147	Flat washer	6	4	
148	Oil temperature measure		1	
149	oil absorption filter oil meter		1	
150	motor		1	
151	Hydraulic cylinder		1	
152	Motor tube		2	进 2.4 出 1.6
153	Hydraulic cylinder tube		2	进 2.6 出 1.8
154	Drain mouth matching oil plug		1	
155	double row roller chain	10A	2	各 40 节

**Note:** This manual is only for your reference. Owing to the continuous improvement of the machine, changes may be made at any time without obligation on notice. And please note the local voltage while operating this electric machine.