

KAKA Industrial®

Specifications

UB-70:

Stock No.173201

Cold bending:

Flat steel.....70 x 6 mm($2\frac{3}{4}$ "x $\frac{1}{4}$ ")

Square steel.....16 x 16 mm($\frac{5}{8}$ "x $\frac{5}{8}$ ")

Round steel.....18 mm($\frac{11}{16}$ ")

Angle steel.....60 x 8 mm($2\frac{3}{8}$ "x $\frac{5}{16}$ ")

Warm bending:

Flat steel.....70 x 10 mm($2\frac{3}{4}$ "x $\frac{3}{8}$ ")

Square steel.....18 x 18 mm($\frac{11}{16}$ "x $\frac{11}{16}$ ")

Round steel.....20 mm($\frac{3}{4}$ ")

Angle steel.....70 x 15 mm($2\frac{3}{4}$ "x $\frac{5}{8}$ ")

UB-100:

Stock No.173202

Cold bending:

Flat steel.....100 x 5 mm(4 "x $\frac{3}{16}$ ")

Square steel.....16 x 16 mm($\frac{5}{8}$ "x $\frac{5}{8}$ ")

Round steel.....18 mm($\frac{3}{4}$ ")

Angle steel.....60 x 8 mm($2\frac{3}{8}$ "x $\frac{5}{16}$ ")

Warm bending:

Flat steel.....100 x 10mm(4 "x $\frac{3}{8}$ ")

Square steel.....18 x 18 mm($\frac{11}{16}$ "x $\frac{11}{16}$ ")

Round steel.....20 mm($\frac{3}{4}$ ")

Angle steel.....100 x 12 mm(4 "x $\frac{7}{16}$ ")

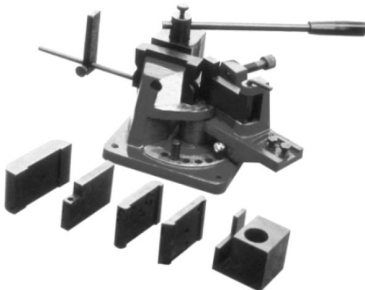

Unpacking

The UNIVERSAL BENDER UB-70 & UB-100 is shipped from the manufacture in a carefully packed Carton box.

Thoroughly inspect the product upon opening the package. After unpacking the unit, carefully inspect for any damage that may have occurred during transit.

If damage has occurred, shipping damage claims must be filed with the carrier and are the responsibility of the user.

Check for completeness. Immediately report missing parts to dealer.

▲WARNING

The warnings, cautions and instructions discussed in this instructions or situations that could occur. It must be understood by the operator that common sense and caution are factors which cannot be built into this product, but must be supplied by the operator.

SAVE THESE INSTRUCTIONS

Thank you for purchasing UNIVERSAL BENDER UB-70/UB-100. Before attempting to operate your new tool please read these instructions thoroughly. You will need these instructions for the safety warnings, precautions, assembly,

Model UB-70/UB-100

operation, maintenance procedures, parts list and diagrams. Keep your invoice number with these instructions. Write the invoice number on the inside of front cover. Keep the instructions and invoice in a safe, dry place for future reference.

SAFETY RULES

1. **Know your machine.** Read this manual carefully. Learn the machine's applications and limitations, as well as specific potential hazards peculiar to it.
2. **Keep work area clean and well lit.** Cluttered or dark work areas invite accidents.
3. **Keep Children away.** All children should be kept away from the work area. Never let a child handle a tool without strict adult supervision.
4. **Do not operate this tool if under the influence of alcohol or drugs.** Read warning labels on prescriptions to determine if your judgment or reflexes are impaired while taking drugs. If there is any doubt, do not attempt to operate.
5. **Use safety equipment.** Eye protection should be worn always when operating this machine. Use ANSI approved safety glasses. Everyday eyeglasses only have impact resistant lenses. They are NOT safety glasses. Dust mask, non-skid safety shoes, hard hat, or hearing protection should be used in appropriate conditions.
6. **Wear proper apparel.** Loose clothing, gloves, neckties, rings, bracelets, or other jewelry may present a potential hazard when operating this machine. Please keep all apparel clear of the machine.
7. **Don't overreach.** Keep proper footing and balance always when operating this product.
8. **Check for damage.** Check your tool regularly. If part of the tool is damaged it should be carefully inspected to make sure that it can perform its' intended function correctly. If in doubt, the part should be repaired. Refer all servicing to a qualified technician. Consult your dealer for advice.
9. **Keep your hands away from the die when you are working on it.**
10. **Avoid moving parts during operation.** Deep fingers and hands away from moving parts.
11. **Stay alert.** Watch what you are doing. Use common sense. Do not operate any tool when you are tired.
12. **Replacement parts and accessories.** When servicing, use only identical

KAKA Industrial®

replacement parts. Only use accessories intended for use with this tool.

13. **Store idle equipment.** When not in use, the tool should be stored in a dry location to inhibit rust. Store in an area out of reach of children.

14. **Don't force the machine or tool.** It will do the job better and more safely at the rate for which it was intended.

15. **Use the right tool.** Don't force a small tool or attachment to do the work of a larger industrial tool, Don't use a tool for a purpose for which it was not intended.

16. **Secure work.** Make sure the unit is securely mounted to a stable surface before operation.

Important:

The universal bender is coated with a protectant. To ensure proper fit and operation, remove coating. Coating is easily removed with mild solvents, such as mineral spirits, and a soft cloth. Avoid getting cleaning solution on paint or any of the rubber or plastic parts. Solvents may deteriorate these finishes. Use soap and water on paint, plastic or rubber components. After cleaning, cover all exposed surfaces with a light coating

of oil.

Assembly

▲WARNING

Before drilling the mounting holes, make sure that there is no interference with electrical conduit or water pipes.

The Universal Bender must be securely mounted to a solid surface before using. Operating the tool for certain operations will require exerting considerable force on the handle, thus it is essential that the tool be mounted to a heavy or immovable work bench or other work surface. Be certain there will be adequate clearance for the entire range of motion of the handle with no potential pinch points for the operator's hands.

1. Attach the base (#14) to a solid workbench using the 12mm mounting holes.
2. Secure the handle (#25) to the rotating body (#10) using bolts (#28), spring washer (#29), washer(#30). (See Figure 1).

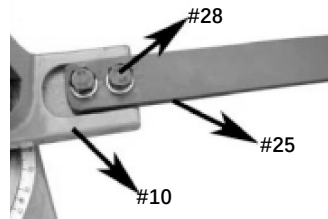

Figure 1

Model UB-70/UB-100

3.Insert screw bolt (#4) into the hole on base (#14), and then tighten set screw (#2) to make support plate (#1) fix tightly with screw bolt (#4). (refer to figure 2).

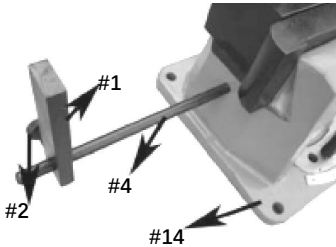

Figure 2

4.Insert crank rod (#17) with grooved surface facing up, and insert it into the hole of eccentric shaft (#16), insert screw (#2) into groove and tighten (refer to figure 3). The universal bender is now ready to use .

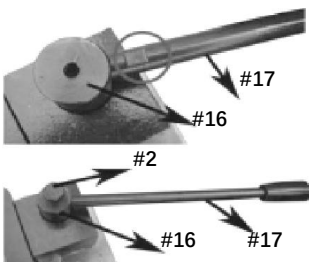

Figure 3

Operation

▲WARNING

Do not bend a stock thicker than the bender capacity. You will damage the bender. Measure the thickness before use.

The universal bender includes different bending plates and blocks, refer to figure 4. Eccentric block (#18), bending plate forming board (#3) and clamping plate (#5) are assembled on the bender. Dies can be changed as needed for different bend types.

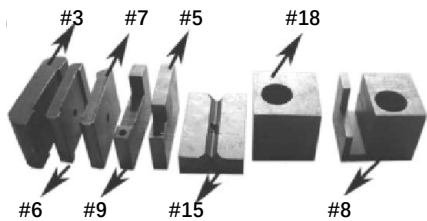

Figure 4

1.Clamp the work-piece with the dies, and move the edge of the eccentric block (#18) close to the work-piece by turning the crank rod (#17) (refer to figure 5).

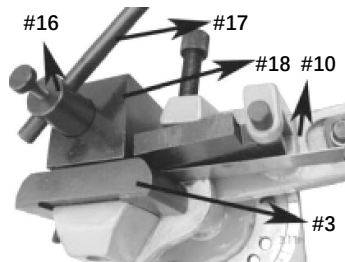
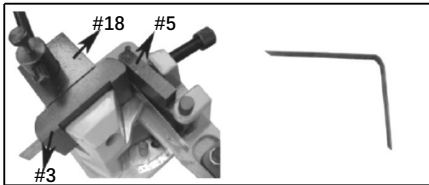

Figure 5

KAKA Industrial®

2. Turn the rotating body (#10) by using the handle (#25) to bend the work piece as desired (part #10 & #25, please refer to Figure 1).

3. Different bending functions shown below from (1) to (5).



(1)

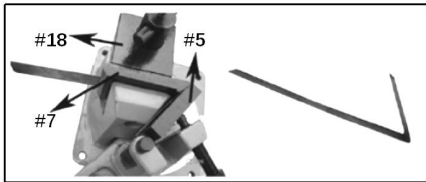

(2)

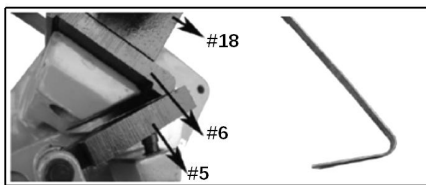

(3)

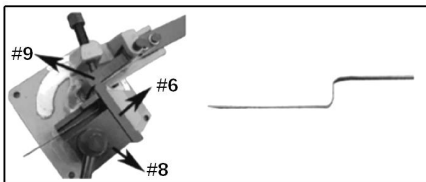

(4)

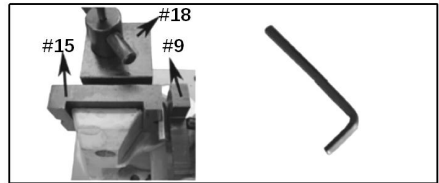

(5)

Maintenance

1. Consult manual for specific maintaining and adjusting procedures.
2. Only use soap and a damp cloth to clean your tools. Many household cleaners are harmful to plastics and other insulation. Never let liquid get inside a tool.
3. Keep tool lubricated and clean for safest operation.
4. Remove adjusting tools. Form habit of checking to see that adjusting tools are removed before using machine.
5. Keep all parts in working order. Check to determine that the guard or other parts will operate properly and perform their intended function.
6. Check for damaged parts. Check for alignment of moving parts, binding, breakage, and mounting or any other condition that may affect a tool's operation.

Model UB-70/UB-100

Parts List

PART#	DESCRIPTION	QTY	PART#	DESCRIPTION	QTY
1	Support plate	1	17	Crank rod	1
2	Screw	2	18	Eccentric block	1
3	Forming board	1	19	Pin	1
4	Bolt	1	20	Scale	1
5	Plate	1	21	Rivets 2X5	3
6	Forming board	1	22	Screw M12X35	1
7	Forming board	1	23	Screw M12X30	1
8	Eccentric block	1	24	Grip M12	1
9	Plate	1	25	Handle	1
10	Rotating body	1	26	Bolt M8X25	1
11	Bolt	1	27	Nut M8	1
12	Pin	1	28	Bolt M10X25	2
13	Shaft	1	29	Spring washer 10	2
14	Base	1	30	Washer 10	2
15	Forming board	1	31	Rubber grip	1
16	Eccentric shaft	1			

Drawing

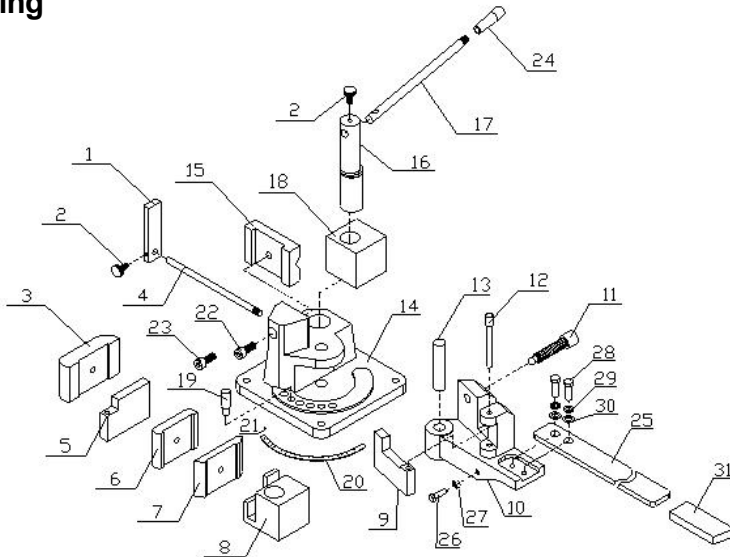

SERVICE RECORD

KAKA Industrial®

Date	Maintenance performed	Repair components require

NOTES

Stock No: 173201/173202

Edition 1 04/2018

Copyright © 2018 KAKA



If you have any questions about the use of this product, please contact the nearest one to you as below:

KAKA INDUSTRIAL LLC

Mail:

info@kakaindustrial.com

Add: 4200 Steve Reynolds
Blvd Ste 6 Norcross,
GA 30093
U.S.A.

KAKA INDUSTRIAL LTD

Mail:

echo@kakaindustrial.com

Add: 3143 Underhill Avenue
Burnaby,
B.C V5A3C8
Canada

KANG INDUSTRIAL PTY LTD

Mail:

kang@kakaindustrial.com

Add: 3 Wayne Court
Dandenong,
VIC 3175
Australia