

Modell der

Serie 54/Bauart NOHAB

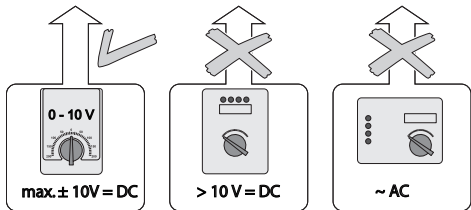

max. $\pm 10V = DC$

$> 10V = DC$

$\sim AC$

67011

67020 + 67030

67201

67271

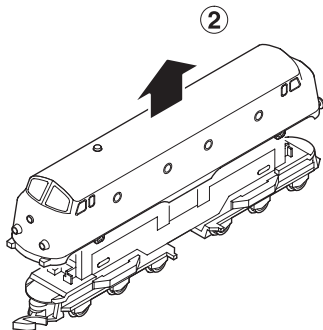
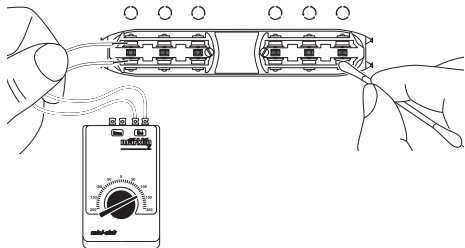
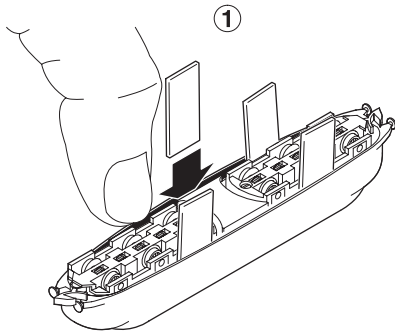

2

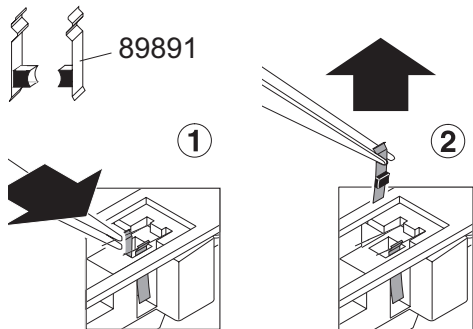
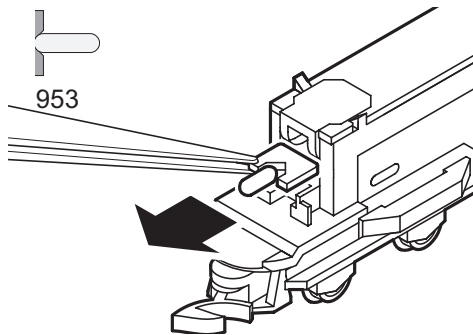
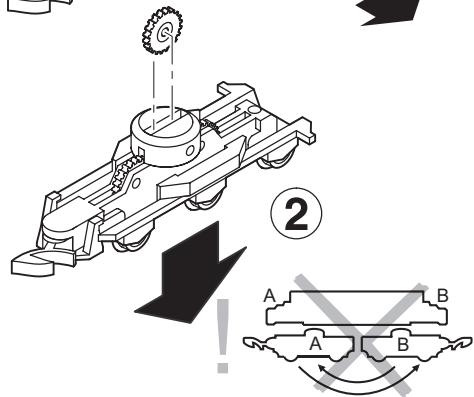
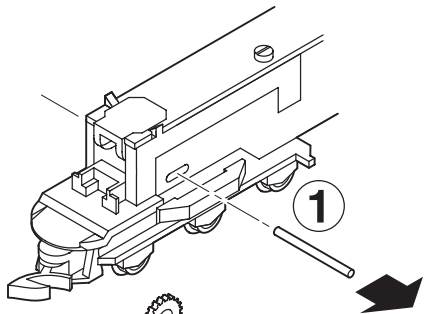

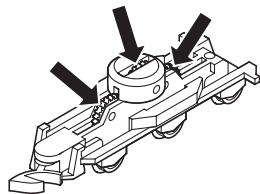
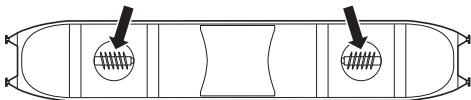
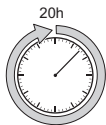

- Nur sparsam ölen (max. 1 Tropfen). Zuviel Öl führt häufig zum Verschmieren der Kollektoren und damit zur Beschädigung des Ankers.
- Oil sparingly (max. 1 drop). Too much oil frequently causes the commutator to become dirty and thereby leads to damage to the armature.

- Lubrifi ez en très petite quantité (1 goutte max.). Trop d'huile entraîne souvent l'encrassement du collecteur et à des dommages à l'induit.
- Na het aanbrengen van de oliedruppel op het motorlager het anker ronddraaien. Aansluitend met een droge doek de overvloedige olie verwijderen.

Gebr. Märklin & Cie. GmbH
Postfach 860
D-73008 Göppingen
www.maerklin.com



www.maerklin.com/api

612064/0705/SmEf
Änderungen vorbehalten
© Gebr. Märklin & Cie. GmbH