

Modell der BR 150 / E 50

**88575**

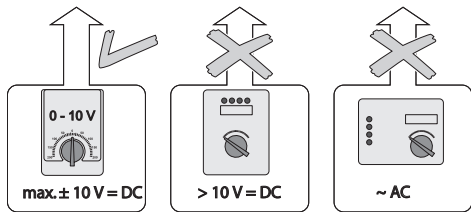

max.  $\pm 10\text{ V} = \text{DC}$   
67011  
67020 + 67030  
67201  
67271

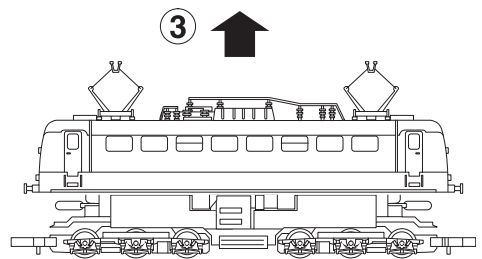
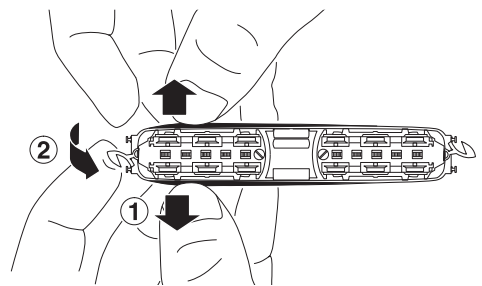

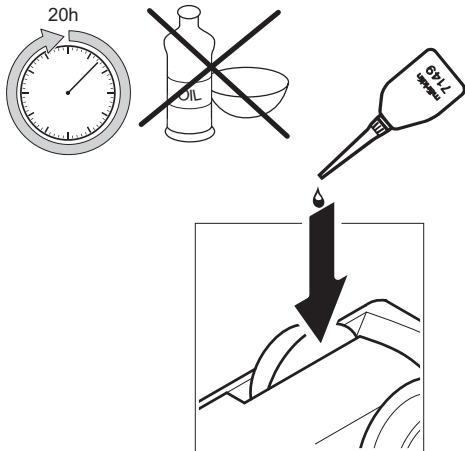

- Nur sparsam ölen (max. 1 Tropfen). Zuviel Öl führt häufig zum Verschmieren der Kollektoren und damit zur Beschädigung des Ankers.
- Oil sparingly (max. 1 drop). Too much oil frequently causes the commutator to become dirty and thereby leads to damage to the armature.
- Lubrifiez en très petite quantité (1 goutte max.). Trop d'huile entraîne souvent l'encrassement du collecteur et à des dommages à l'induit.
- Slechts spaarzaam oliën (max. 1 druppel). Te veel olie leidt vaak tot versmeren van de collector en daarmee tot beschadiging van het anker.

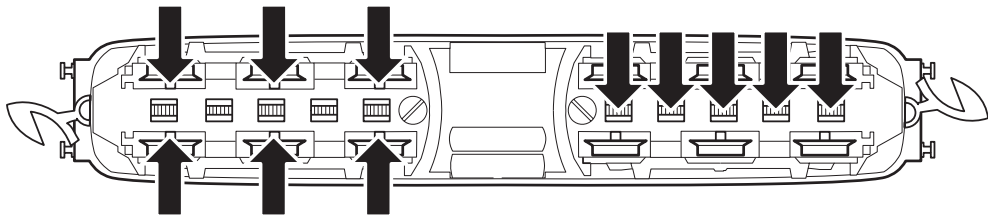

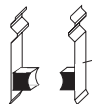
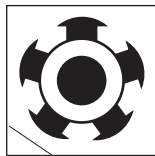

89891



8953

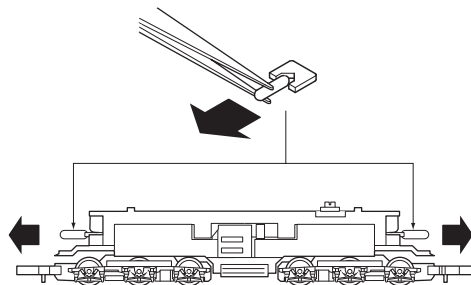
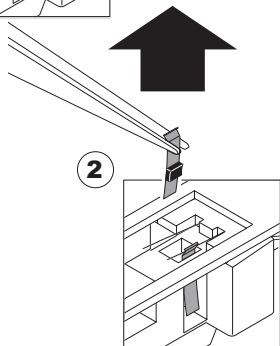
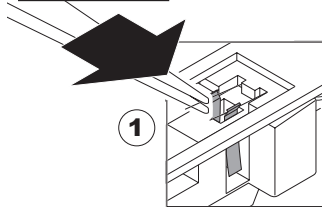

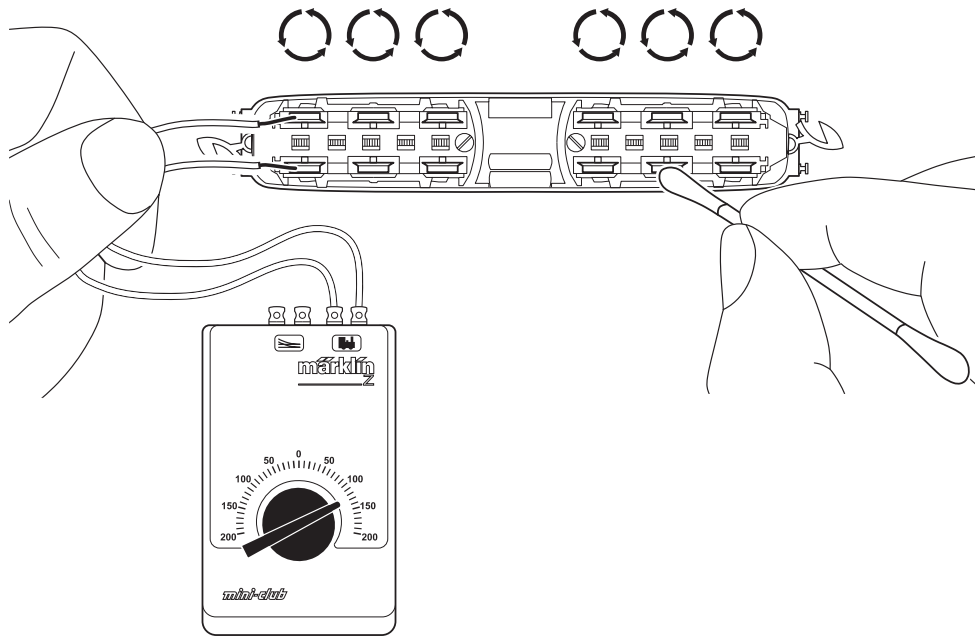

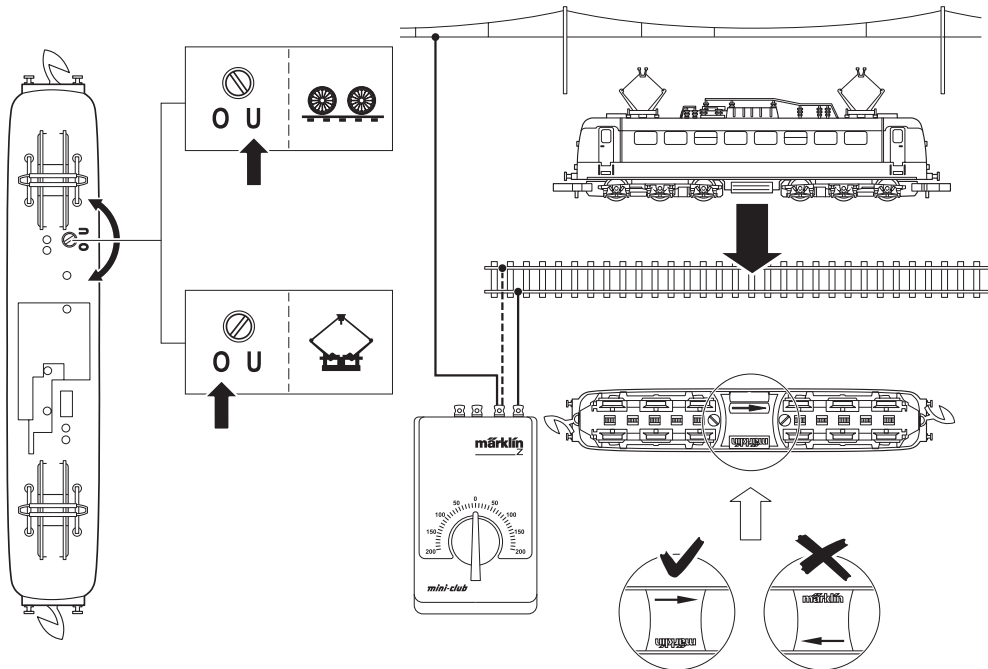

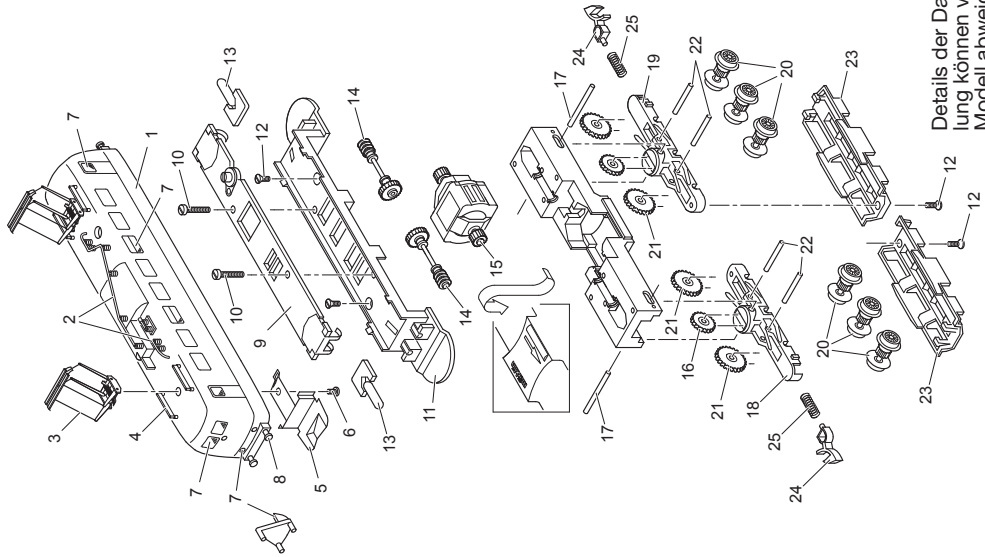

Details der Darstellung können von dem Modell abweichen

1 Aufbau	117 861
2 Dachleitungen und Isolatoren	117 882
3 Dachstromabnehmer	262 470
4 Trägerisolation	117 868
5 Abschirmblech	262 740
6 Zylinderschraube	785 150
7 Glasteile	117 883
8 Puffer	761 790
9 Leiterplatte	223 329
10 Zylinderschraube	785 190
11 Isolierung	223 332
12 Senkschraube	785 550
13 Beleuchtungseinsatz	8 953
14 Antriebswelle	262 310
15 Motor	211 903
Motorbürsten	89 891
16 Zahnrad	262 190
17 Achse	260 720
18 Getriebegehäuse vorn	262 450
19 Getriebegehäuse hinten	262 460
20 Treibradsatz	215 827
21 Zahnrad	260 730
22 Achse	262 240
23 Drehgestellrahmen	262 280
24 Kupplungshaken	704 200
25 Feder	765 680

Gebr. Märklin & Cie. GmbH  
Postfach 860  
D-73008 Göppingen  
www.maerklin.com

117881/0407/SmSk  
Änderungen vorbehalten  
© Gebr. Märklin & Cie. GmbH