

Modell der

BR E 10.3

88411

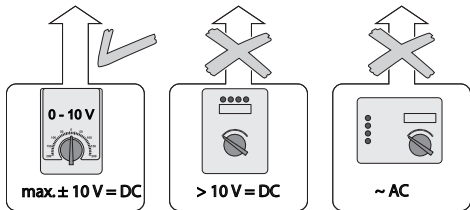

max. ± 10 V = DC

> 10 V = DC

~ AC

67011
67020 + 67030
67201
67271

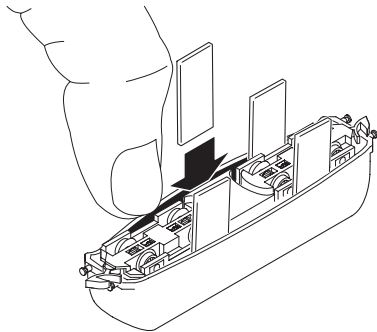

1

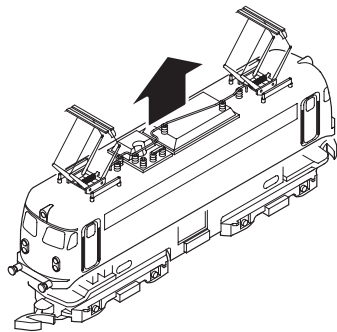

2

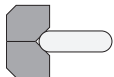

8953

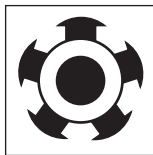
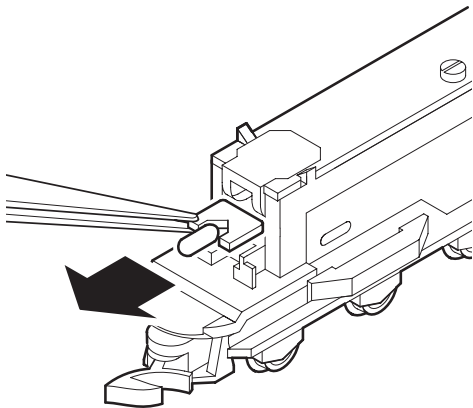

89891

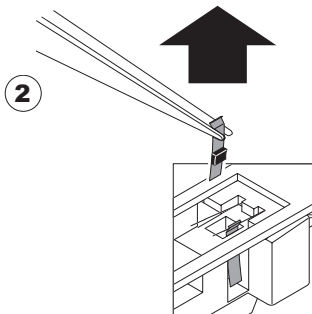
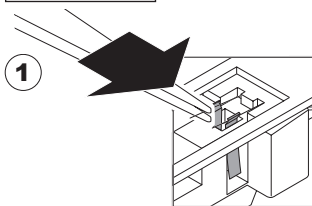

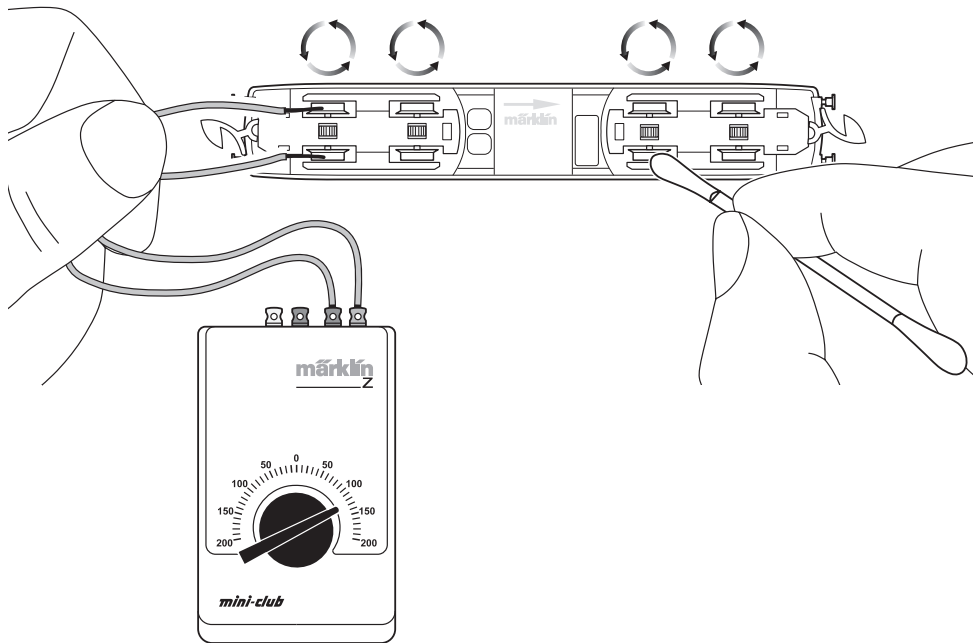

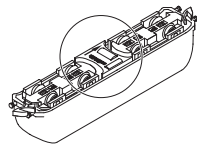
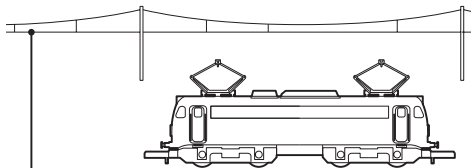
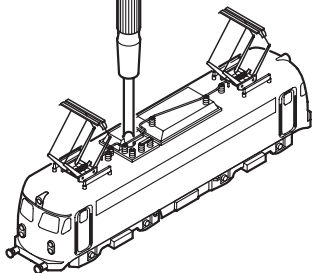
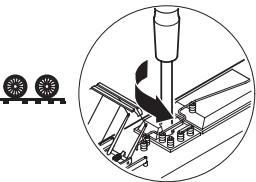
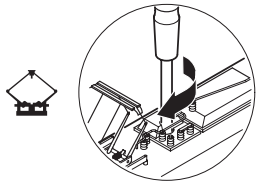

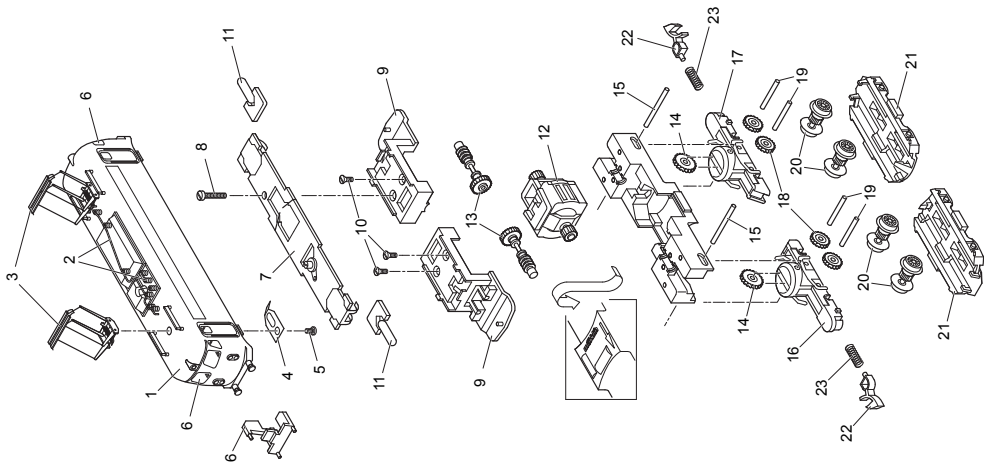

1	Aufbau komplett mit	100 876
2	Dachausrüstung	105 803
3	Dachstomabnehmer	262 470
4	Kontaktfeder	326 407
5	Zylinderschraube	785 150
6	Glasteile	105 805
7	Leiterplatte	264 480
8	Zylinderschraube	785 190
9	Isolierung	263 030
10	Senkschraube	785 550
11	Beleuchtung	8 953
12	Motor	211 903
13	Antriebswelle	263 020
14	Zahnrad	262 960
15	Achse	260 720
16	Getriebegehäuse vorn	264 450
17	Getriebegehäuse hinten	264 460
18	Zahnrad	262 190
19	Achse	262 240
20	Treibradsatz	220 183
21	Drehgestellrahmen	268 750
22	Kupplungshaken	704 200
23	Druckfeder	765 680

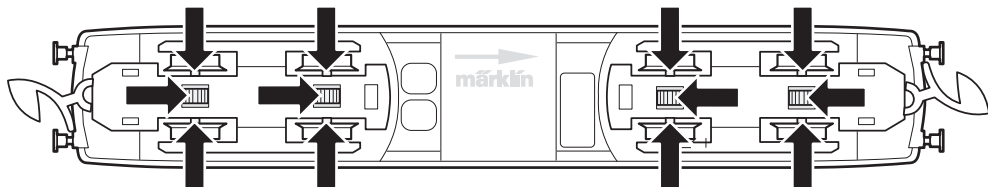
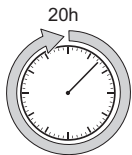

Gebr. Märklin & Cie. GmbH
Postfach 860
D-73008 Göppingen
www.maerklin.com

100878/0506/SmEf
Änderungen vorbehalten
© Gebr. Märklin & Cie. GmbH