

Modell der

BR 05

88105

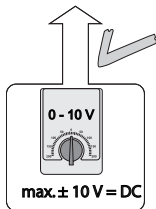

max. $\pm 10\text{ V} = \text{DC}$

67011
67020 + 67030
67201
67271

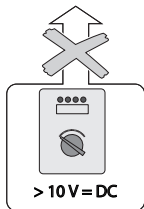

$> 10\text{ V} = \text{DC}$

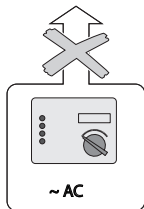

$\sim \text{AC}$

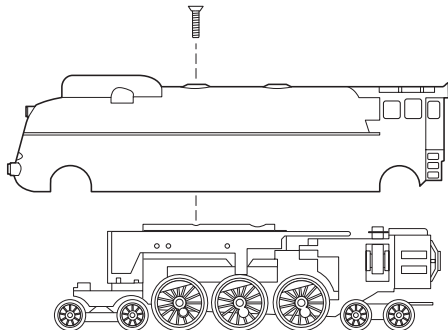

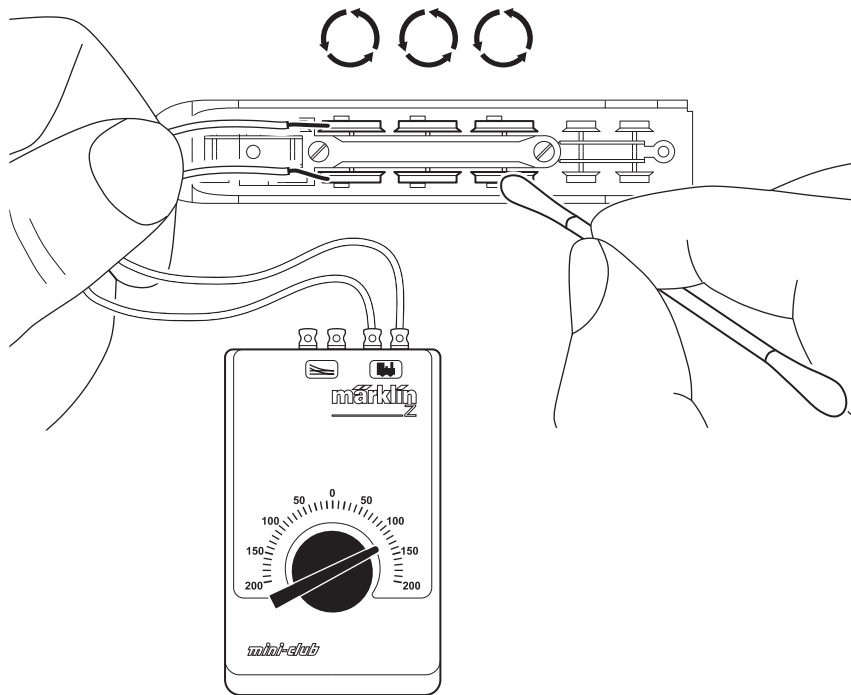

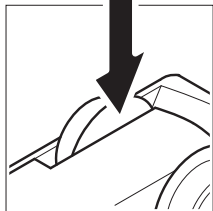
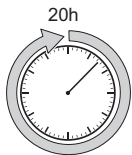

- Nur sparsam ölen (max. 1 Tropfen). Zuviel Öl führt häufig zum Verschmieren der Kollektoren und damit zur Beschädigung des Ankers.
- Oil sparingly (max. 1 drop). Too much oil frequently causes the commutator to become dirty and thereby leads to damage to the armature.
- Lubrifiez en très petite quantité (1 goutte max.). Trop d'huile entraîne souvent l'encrassement du collecteur et à des dommages à l'induit.
- Slechts spaarzaam oliën (max. 1 druppel). Te veel olie leidt vaak tot versmeren van de collector en daarmee tot beschadiging van het anker.

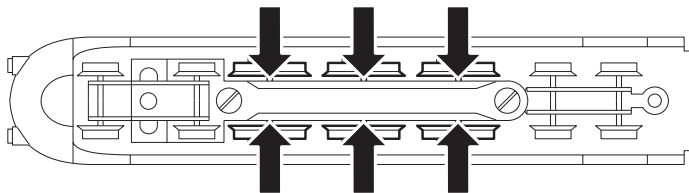

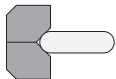

8953

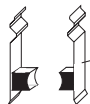
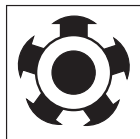
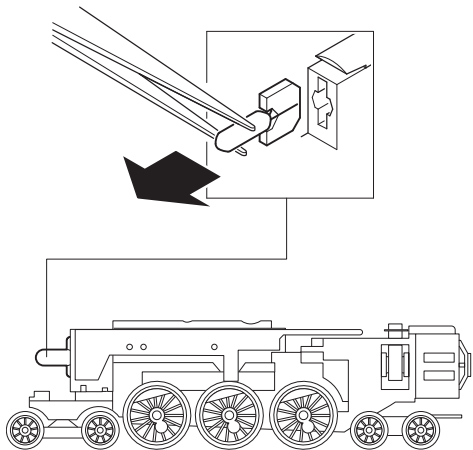

89891

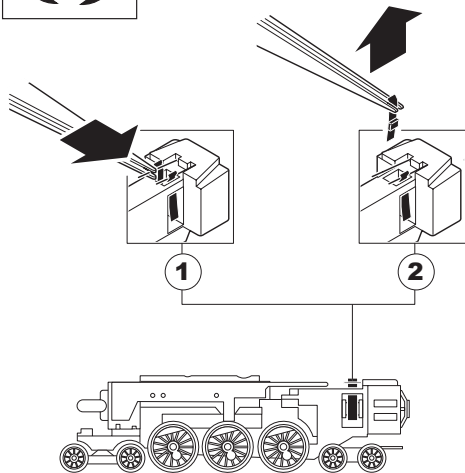

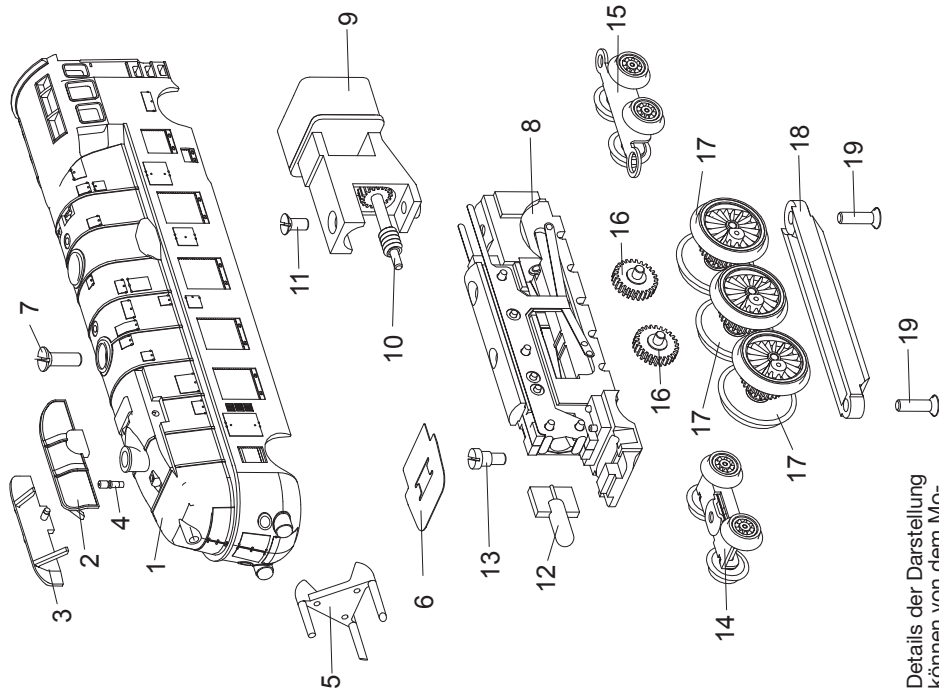

Details der Darstellung
können von dem Mo-
dell abweichen

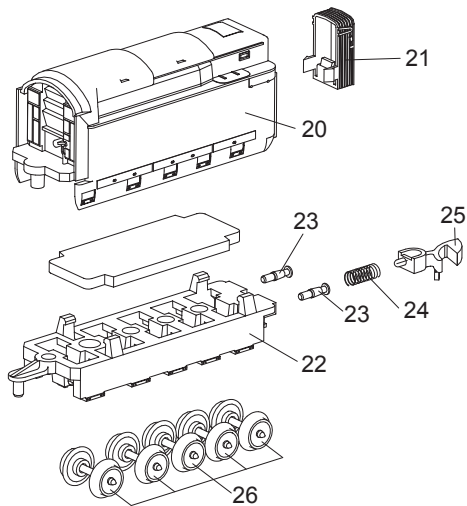

Details der Darstellung
können von dem Mo-
dell abweichen

1 Lok-Aufbau (komplett)	100 624
2 Windleitblech links	100 629
3 Windleitblech rechts	100 627
4 Pfeife	110 483
5 Lichtkörper	100 631
6 Abdeckung	450 450
7 Senkschraube	19 8327 28
8 Traggestell	100 637
9 Motor	211 909
Motorbürsten	89891
10 Antriebsschnecke	261 460
11 Senkschraube	785 550
12 Beleuchtungseinsatz	8 953
13 Zylinderansatzschraube	753 130
14 Drehgestell vorne	223 557
15 Drehgestell hinten	100 643
16 Zwischenradsatz	261 280
17 Treibradsatz	223 559
18 Abdeckung	261 050
19 Senkschraube	785 570
20 Tender-Aufbau	100 633
21 Faltenbalg	702 870
22 Boden	100 636
23 Puffer	761 450
24 Druckfeder	765 680
25 Kupplungshaken	704 200
26 Radsatz	215 721

Gebr. Märklin & Cie. GmbH
Postfach 860
D-73008 Göppingen
www.maerklin.com

105097/1006/SmEf
Änderungen vorbehalten
© Gebr. Märklin & Cie. GmbH

www.ajckids.com