

Modell der

BR 39 (P10)

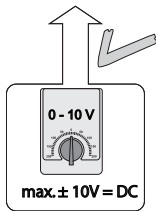
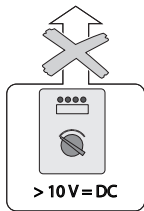

max. $\pm 10V = DC$

67011
67020 + 67030
67201
67271



$> 10V = DC$

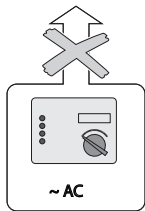

$\sim AC$

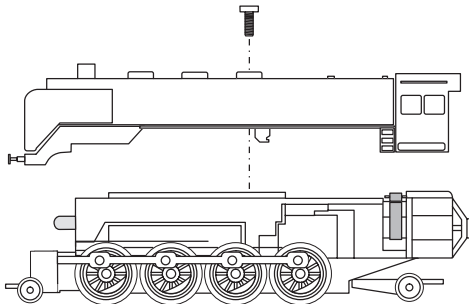
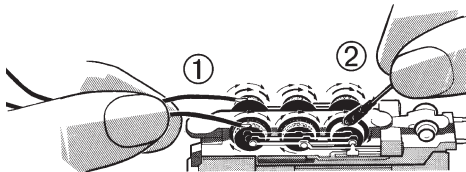
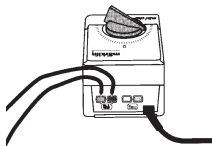

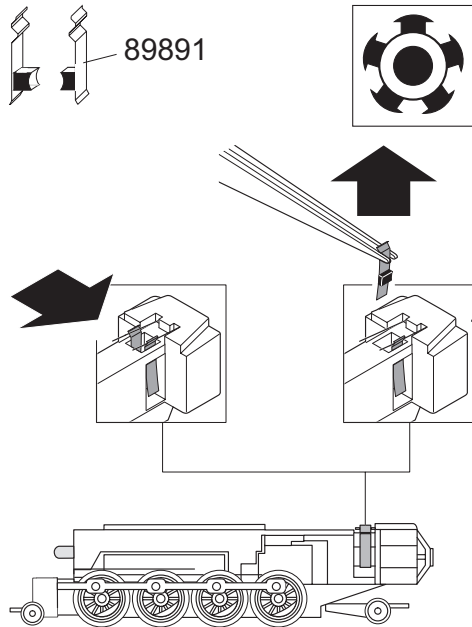
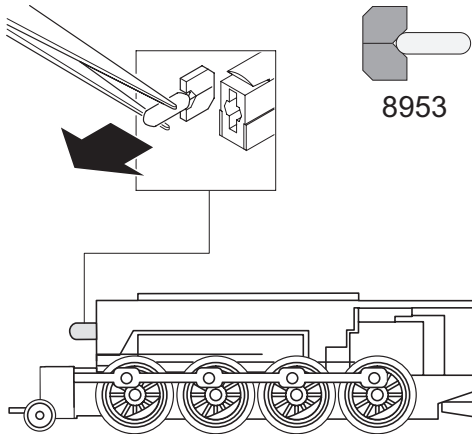

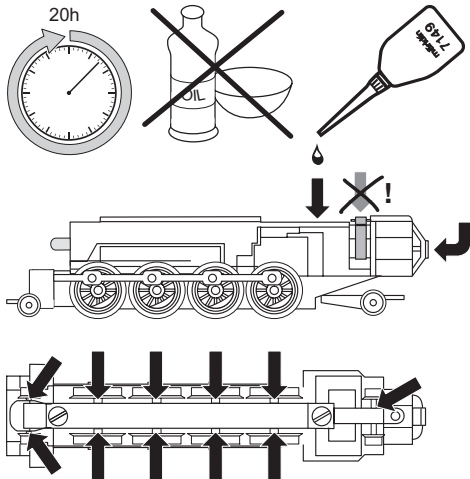

- Nur sparsam ölen (max. 1 Tropfen). Zuviel Öl führt häufig zum Verschmieren der Kollektoren und damit zur Beschädigung des Ankers.
- Oil sparingly (max. 1 drop). Too much oil frequently causes the commutator to become dirty and thereby leads to damage to the armature.
- Lubrifiez en très petite quantité (1 goutte max.). Trop d'huile entraîne souvent l'encrassement du collecteur et à des dommages à l'induit.
- Na het aanbrengen van de oliedruppel op het motorlager het anker ronddraaien. Aansluitend met een droge doek de overvloedige olie verwijderen.

Gebr. Märklin & Cie. GmbH
 Postfach 860
 D-73008 Göppingen
 www.maerklin.com



609498/0605/SmEf
 Änderungen vorbehalten
 © Gebr. Märklin & Cie. GmbH