

Modell der

BR 42.90

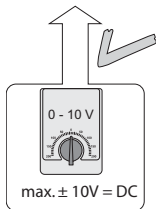

max. $\pm 10V = DC$

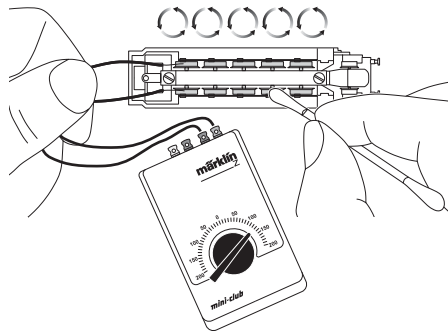
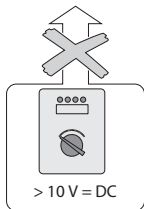

$> 10V = DC$

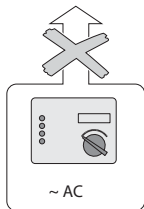

$\sim AC$

67011
67020 + 67030
67201
67271

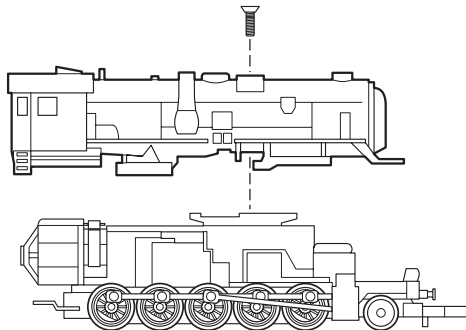

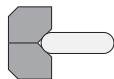
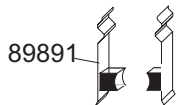

8953

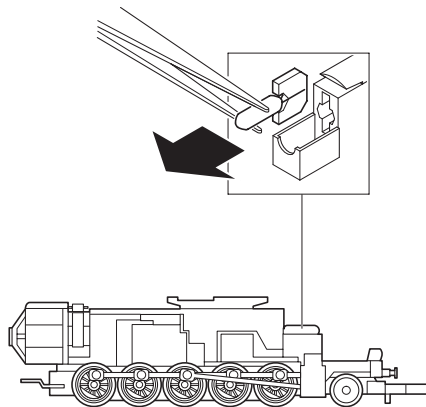
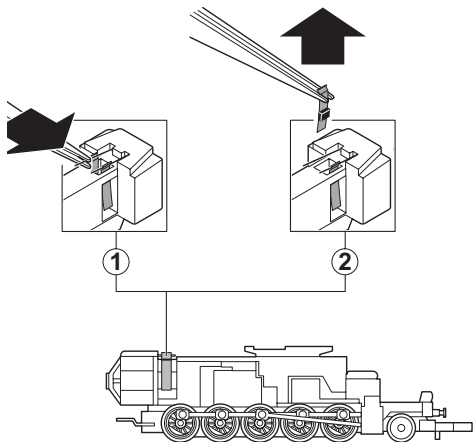

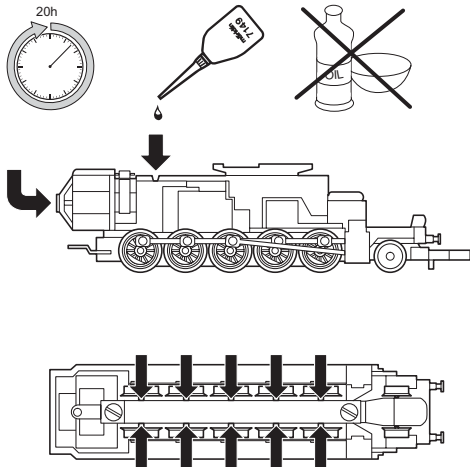

- Nur sparsam ölen (max. 1 Tropfen). Zuviel Öl führt häufig zum Verschmieren der Kollektoren und damit zur Beschädigung des Ankers.
- Oil sparingly (max. 1 drop). Too much oil frequently causes the commutator to become dirty and thereby leads to damage to the armature.
- Lubrifiez en très petite quantité (1 goutte max.). Trop d'huile entraîne souvent l'encrassement du collecteur et à des dommages à l'induit.
- Slechts spaarzaam oliën (max. 1 druppel). Te veel olie leidt vaak tot versmeren van de collector en daarmee tot beschadiging van het anker.

Gebr. Märklin & Cie. GmbH
 Postfach 860
 D-73008 Göppingen
 www.maerklin.com



608736/0205/SmNa
 Änderungen vorbehalten
 © Gebr. Märklin & Cie. GmbH