

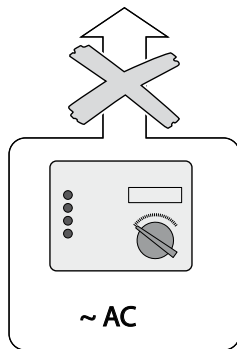

mini-club

Modell der Dampflokomotive BR 50

81864

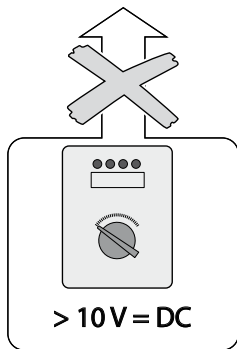
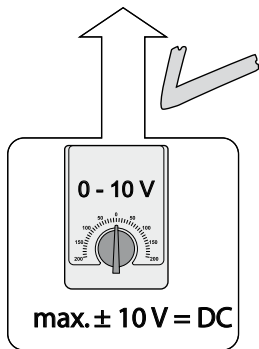

67013

67020 + 67030

67201

67271

Sicherheitshinweise

- **ACHTUNG!** Funktionsbedingte scharfe Kanten und Spitzen.
- Das verwendete Gleisanschlusskabel darf maximal 2 Meter lang sein.

Safety Notes

- **WARNING!** Sharp edges and points required for operation.
- The wire used for feeder connections to the track may only be a maximum of 2 meters / 78 inches long.

Remarques importantes sur la sécurité

- **ATTENTION !** Pointes et bords coupants lors du fonctionnement du produit.
- Le câble de raccordement à la voie utilisé ne doit en aucun cas dépasser deux mètres.

Veiligheidsvoorschriften

- **OPGEPAST!** Functionele scherpe kanten en punten.
- De gebruikte aansluitkabel mag maximaal 2 meter lang zijn.

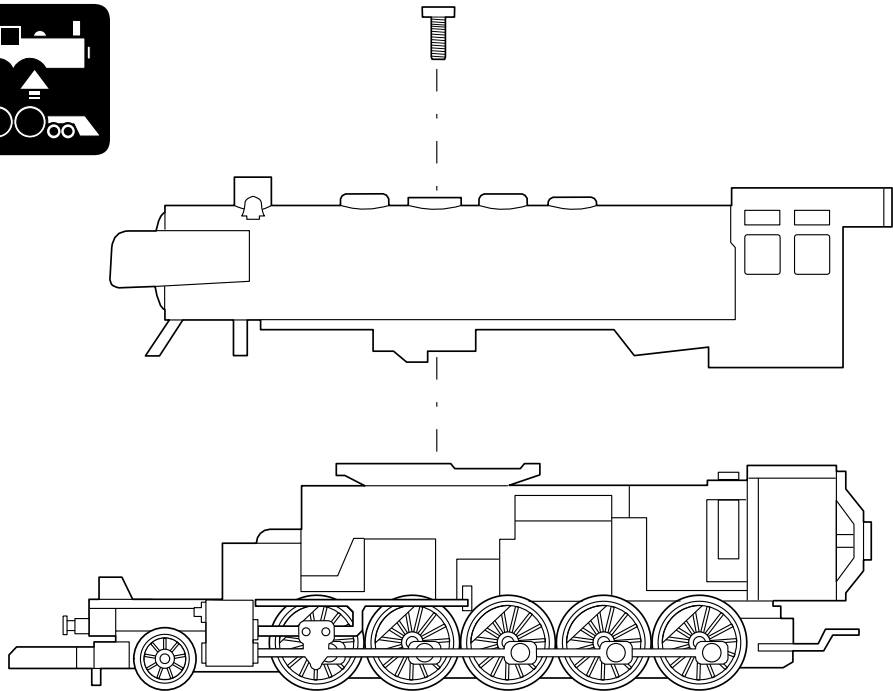

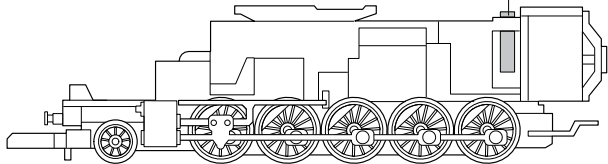
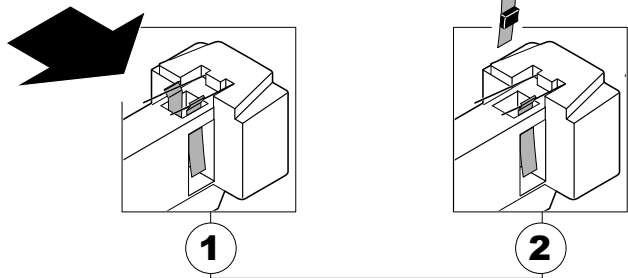
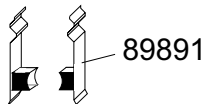
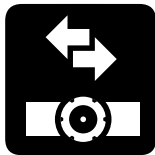

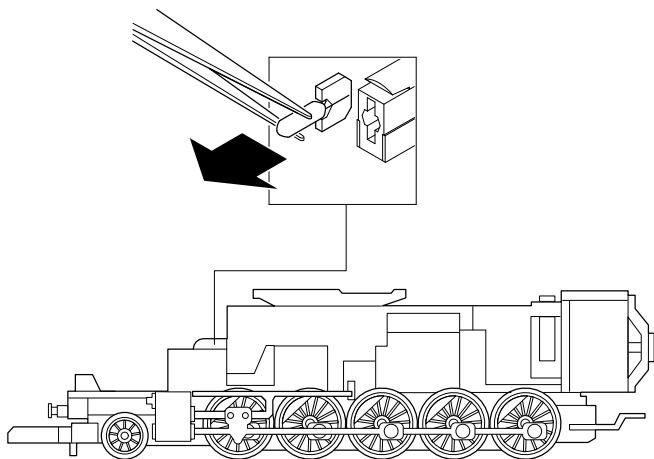
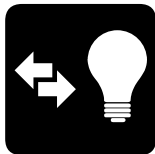

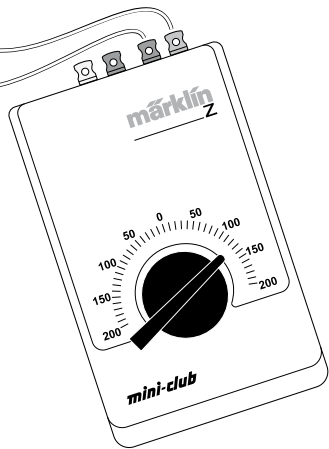
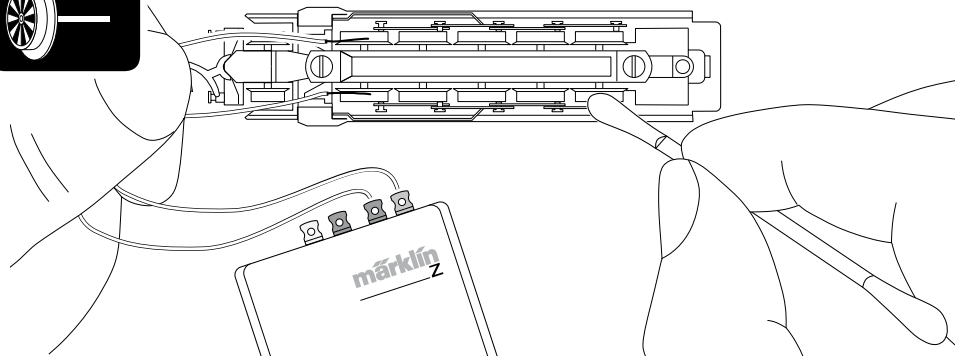
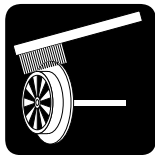



- Nur sparsam ölen (max. 1 Tropfen). Zuviel Öl führt häufig zum Verschmieren der Kollektoren und damit zur Beschädigung des Ankers.
- Oil sparingly (max. 1 drop). Too much oil frequently causes the commutator to become dirty and thereby leads to damage to the armature.

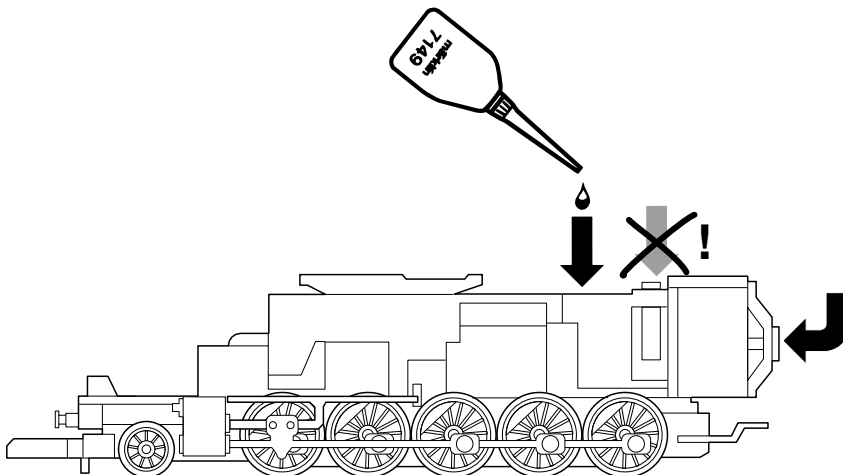

- Lubrifiez en très petite quantité (1 goutte max.). Trop d'huile entraîne souvent l'encrassement du collecteur et à des dommages à l'induit.
- Slechts spaarzaam oliën (max. 1 druppel). Te veel olie leidt vaak tot versmeren van de collector en daarmee tot beschadiging van het anker.

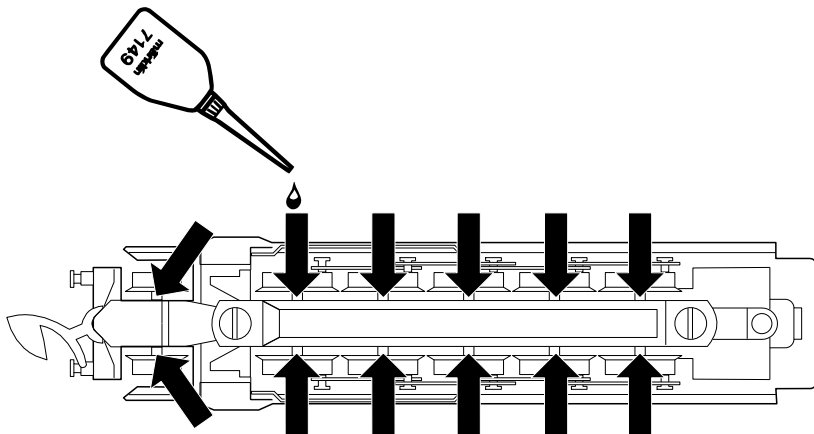

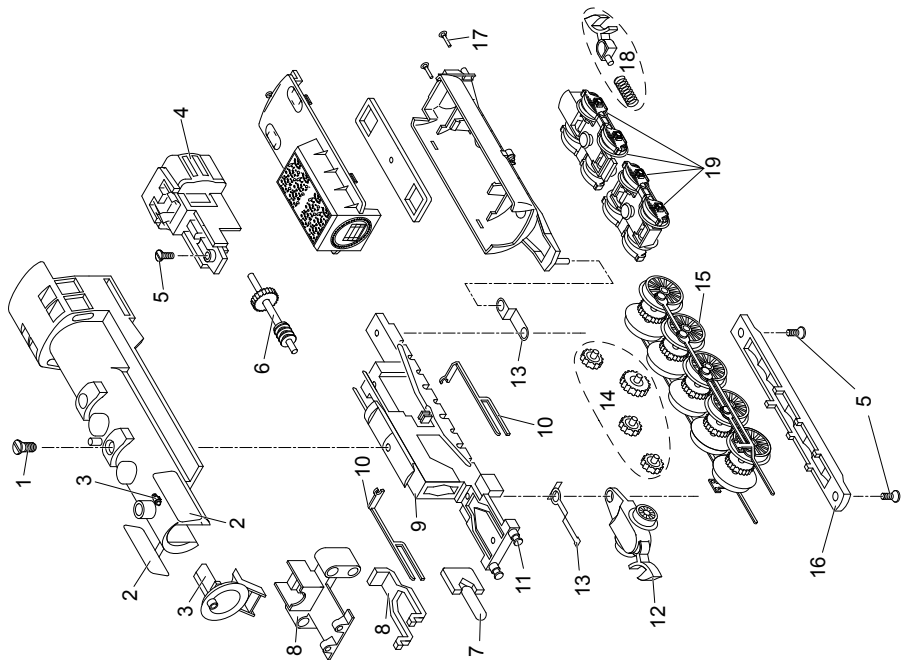



1	Schraube	E756 100
2	Windleitbleche	—
3	Steckteile Kessel	E183 068
4	Motor	E211 915
5	Schraube	E785 550
6	Antriebswelle	E226 940
7	Beleuchtungseinheit	8 953
8	Zylinderblock, Lichtkörper	E183 069
9	Traggestell	E268 860
10	Kreuzkopfführung, rechts und links	E183 070
11	Puffer	E761 480
12	Laufgestell	E225 624
13	Kuppelblech	E192 300
14	Zwischenradsätze	E183 072
15	Treibradsätze mit Gestänge	E216 122
16	Abdeckung	E267 300
17	Puffer	E761 790
18	Kupplung	E166 264
19	Radsatz	E215 721

Due to different legal requirements regarding electro-magnetic compatibility, this item may be used in the USA only after separate certification for FCC compliance and an adjustment if necessary.

Use in the USA without this certification is not permitted and absolves us of any liability. If you should want such certification to be done, please contact us – also due to the additional costs incurred for this.

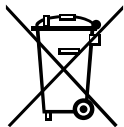
Gebr. Märklin & Cie. GmbH
Stuttgarter Str. 55 - 57
73033 Göppingen
Germany
www.maerklin.com



www.maerklin.com/en/imprint.html

188116/0414/Sm1Ef
Änderungen vorbehalten
© Gebr. Märklin & Cie. GmbH