

Modell der Schnellzug-Dampflokomotive BR 03.10

37918

Inhaltsverzeichnis:	Seite
Informationen zum Vorbild	4
Betriebshinweise	5
Sicherheitshinweise	8
Wichtige Hinweise	8
Funktionen	8
Schaltbare Funktionen	9
Parameter / Register	24
Ergänzendes Zubehör	25
Wartung und Instandhaltung	28
Ersatzteile	32

Table of Contents:	Page
Information about the prototype	4
Information about operation	5
Safety Notes	10
Important Notes	10
Functions	10
Controllable Functions	11
Parameter / Register	24
Complementary accessories	25
Service and maintenance	28
Spare Parts	32

Sommaire :	Page
Informations concernant la locomotive réelle	4
Remarques sur l'exploitation	5
Remarques importantes sur la sécurité	12
Information importante	12
Fonctionnement	12
Fonctions commutables	13
Paramètre / Registre	24
Accessoires complémentaires	25
Entretien et maintien	28
Pièces de rechange	32

Inhoudsopgave:	Pagina
Informatie van het voorbeeld	4
Opmerkingen over de werking	5
Veiligheidsvoorschriften	14
Belangrijke aanwijzing	14
Functies	14
Schakelbare functies	15
Parameter / Register	24
Aanvullende toebehoren	25
Onderhoud en handhaving	28
Onderdelen	32

Indice de contenido:	Página	Innehållsförteckning:	Sidan
Instrucciones de uso	5	Drifthanvisningar	5
Aviso de seguridad	16	Säkerhetsanvisningar	20
Notas importantes	16	Viktig information	20
Funciones	16	Funktioner	20
Funciones posibles	17	Kopplingsbara funktioner	21
Parámetro / Registro	24	Parameter / Register	24
Accesorios complementarios	25	Ytterligare tillbehör	25
El mantenimiento	28	Underhåll och reparation	28
Recambios	32	Reservdelar	32

Indice del contenido:	Página	Indholdsfortegnelse:	Side
Avvertenze per il funzionamento	5	Brugsanvisninger	5
Avvertenze per la sicurezza	18	Vink om sikkerhed	22
Avvertenze importanti	18	Vigtige bemærkninger	22
Funzioni	18	Funktioner	22
Funzioni commutabili	19	Styrbare funktioner	23
Parametro / Registro	24	Parameter / Register	24
Accessori complementari	25	Ekstra tilbehør	25
Manutenzione ed assistere	28	Service og reparation	28
Pezzi di ricambio	32	Reserve dele	32

Informationen zum Vorbild

Von den 45 Exemplaren der ehemaligen Stromlinienlokomotive BR 03.10, die nach 1945 noch vorhanden waren, befanden sich 26 im Bestand der Deutschen Bundesbahn. Mitte der 1950er-Jahre war der Zustand der Kessel bereits so schlecht, dass die DB eine umfangreiche Rekonstruktionsmaßnahme mit neuen Kesseln beschloss. Das Aussehen der Lokomotive veränderte sich dadurch erheblich und ähnelte stark dem der ebenfalls neubekesselten BR 01.10. Allerdings war die Umbaumaßnahme bei der BR 03.10 technisch nicht so gut gelungen wie bei der BR 01.10, so dass die Maschine bald in den Eilzugsdienst abwanderten. Alle waren in Hagen stationiert und wurden bis 1966 ausgemustert.

Information about the Prototype

Of the 45 units of the former class 03.10 streamlined locomotive, which were still in existence after 1945, 26 were on the roster of the German Federal Railroad. By the mid-1950s, the condition of the boilers on these units was so bad that the DB decided to undertake an extensive rebuilding program with new boilers. The appearance of the locomotives changed considerably in the process and resembled the class 01.10 units that had also been equipped with new boilers. However, the rebuilding of the class 03.10 was not so successful technically as with the class 01.10, so that the former soon ended up in fast passenger train service. All of them were stationed in Hagen and were retired by 1966.

Informations concernant la locomotive réelle

Sur les 45 unités de l'ancienne locomotive aérodynamique BR 03.10 encore disponibles après 1945, 26 se trouvaient encore en possession de la Deutsche Bundesbahn. Au milieu des années 1950, la chaudière se trouvait déjà en si mauvais état que la DB décida un vaste programme de reconstruction avec de nouvelles chaudières. La locomotive changea alors radicalement d'allure, se rapprochant énormément de la BR 01.10, également équipée d'une nouvelle chaudière. Toutefois, la transformation de la BR 03.10 n'était techniquement pas aussi réussie que pour la BR 01.10 et les machines furent bientôt affectées au service de trains directs. Toutes les locomotives étaient affectées au dépôt de Hagen et furent réformées jusqu'en 1966.

Informatie van het voorbeeld

Van de 45 exemplaren van de voormalige stroomlijnlocomotief BR 03.10, die na 1945 nog aanwezig waren, bevonden er zich 26 in het bestand van de Deutsche Bundesbahn. Midden jaren 1950 was de toestand van de ketel al zo slecht, dat de DB tot uitgebreide maatregelen wat betreft de reconstructie met nieuwe ketels besloot. Het uiterlijk van de locomotief veranderde daardoor aanzienlijk en leek sterk op de eveneens opnieuw bekotelde BR 01.10. De ombouwmaatregelen waren bij de BR 03.10 technisch niet zo goed geslaagd als bij de BR 01.10, zodat de machine al spoedig naar de snelreindienst verdween. Alle waren in Hagen gestationeerd en werden tot en met 1966 buiten dienst gesteld.

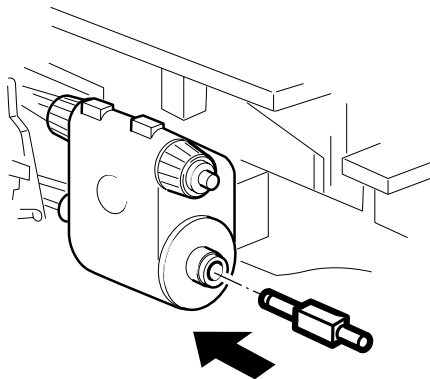
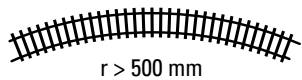
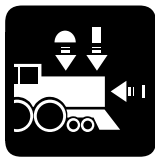
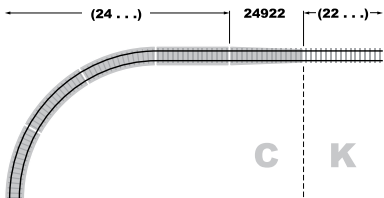
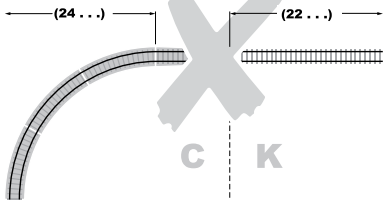

Kurzkupplung zwischen Lok und Tender verstellbar
Close coupling between locomotive and tender is adjustable
Attelage court réglable entre locomotive et tender
Kortkoppeling tussen loc en tender is verstelbaar
El enganche corto ajustable entre locomotora y tender
Aggancio corto regolabile tra locomotiva e tender
Kortkopplet mellan lok och tender kan regleras
Kortkobling mellem lok og tender indstillelig

Wichtig:

Im Fahrbetrieb ($r_{min} = 360 \text{ mm}$): Lok und Tender auf maximalen Abstand einstellen. Nur bei der Präsentation z.B. in einer Vitrine kann der Abstand zwischen Lok und Tender minimiert werden.

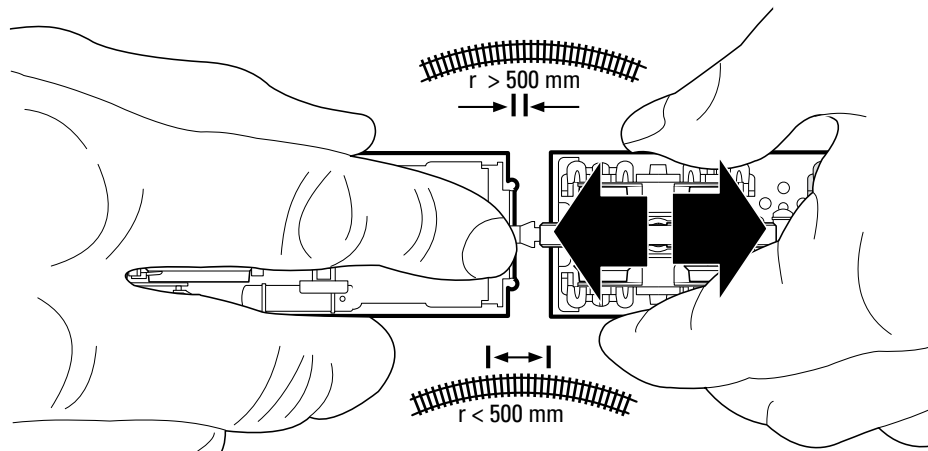

Important:

In regular layout operation (required minimum radius = 360 mm / 14-3/16"): Set the locomotive and the tender for the maximum spacing. The spacing between the locomotive and the tender can be reduced to the minimum only when the model is on display such as in a display case.

Important :

En exploitation ($r_{min} = 360 \text{ mm}$) : Régler l'écart entre locomotive et tender à la valeur maximale. Ne régler l'écart sur une valeur inférieure que pour la présentation, par exemple dans une vitrine.

Belangrijk:

In het rijbedrijf ($r_{min} = 360 \text{ mm}$): loc en tender op de maximale onderlinge afstand instellen. Alleen bij een presentatie bijv. in een vitrine kan de afstand tussen loc en tender geminimaliseerd worden.

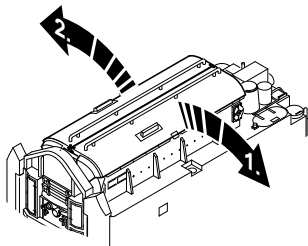
**Importante:**

En funcionamiento: ($r_{min} = 360 \text{ mm}$): regular la distancia entre la locomotora y el tender al máximo. Solo para presentaciones, p.e. en vitrinas, se puede acortar la distancia entre la locomotora y el tender.

Importante:

Nell'esercizio di marcia ($r_{min} = 360 \text{ mm}$): regolare locomotiva e tender per la massima distanza. La distanza tra locomotiva e tender può venire ridotta al minimo soltanto in caso di esposizione, ad es. in una vetrina.

Viktigt:

Ställ in loket och tendern på maximalt avstånd ($r_{min} = 360 \text{ mm}$) under körning. Endast vid presentation, t ex i ett vitrinskåp kan avståndet mellan lok och tender minimeras.

Viktigt:

I køredrift ($r_{min} = 360 \text{ mm}$): Indstil lokomotivet og tenderen til maksimal afstand. Afstanden mellem lokomotivet og tenderen kan kun minimeres ved udstilling, f.eks. i en vitrine.

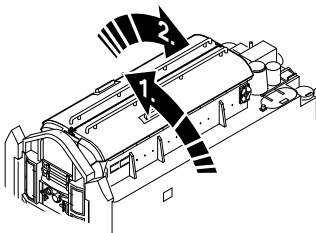

Sicherheitshinweise





- Die Lok darf nur mit einem dafür bestimmten Betriebssystem (Märklin AC, Märklin Delta, Märklin Digital oder Märklin Systems) eingesetzt werden.
- Nur Schaltnetzteile/Transformatoren verwenden, die Ihrer örtlichen Netzspannung entsprechen.
- Die Lok darf nur aus einer Leistungsquelle versorgt werden.
- Beachten Sie unbedingt die Sicherheitshinweise in der Bedienungsanleitung zu Ihrem Betriebssystem.
- Für den konventionellen Betrieb der Lok muss das Anschlussgleis entstört werden. Dazu ist das Entstörset 74046 zu verwenden. Für Digitalbetrieb ist das Entstörset nicht geeignet.
- Setzen Sie das Modell keiner direkten Sonneneinstrahlung, starken Temperaturschwankungen oder hoher Luftfeuchtigkeit aus.
- **ACHTUNG!** Funktionsbedingte scharfe Kanten und Spitzen.

Wichtige Hinweise

- Die Bedienungsanleitung und die Verpackung sind Bestandteile des Produktes und müssen deshalb aufbewahrt sowie bei Weitergabe des Produktes mitgegeben werden.
- Für Reparaturen oder Ersatzteile wenden Sie sich bitte an Ihren Märklin-Fachhändler.
- Gewährleistung und Garantie gemäß der beiliegenden Garantieurkunde.
- Entsorgung: www.maerklin.com/en/imprint.html

Funktionen

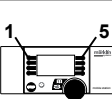
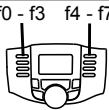
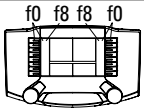
- Erkennung der Betriebsart: automatisch.
- Einstellbare Adressen:
 - 1-80** (Control Unit 6021/Mobile Station 60651/652)
 - 1-255** (Central Station 6021x/Mobile Station 60653)
- Adresse ab Werk: **03**
- Mfx-Technologie für Mobile Station / Central Station.
Name ab Werk: **DB BR 03 1012**
- Veränderbare Anfahrverzögerung (ABV).
- Veränderbare Bremsverzögerung (ABV).
- Veränderbare Höchstgeschwindigkeit.
- Einstellen der Lokparameter (Adresse, Anfahr-/Bremsverzögerung, Höchstgeschwindigkeit):
über Control Unit, Mobile Station oder Central Station.
- Fahrtrichtungsabhängige Stirnbeleuchtung.
- Rauchgenerator ab Werk eingebaut.
- Im Analogbetrieb stehen nur die Fahr- und Lichtwechselfunktionen zur Verfügung.

Schaltbare Funktionen				f0 - f3 f4 - f7 	 Digital/Systems
Spitzensignal	function/off			Funktion f0	Funktion f0
Rauchgenerator	f1	Funktion 1	Funktion 7	Funktion f1	Funktion f1
Geräusch: Betriebsgeräusch	f2	Funktion 2	Funktion 3	Funktion f2	Funktion f2
Geräusch: Lokpfeife	f3	Funktion 3	Funktion 4	Funktion f3	Funktion f3
ABV, aus	f4	Funktion 4	Funktion 2	Funktion f4	Funktion f4
Geräusch: Bremsquietschen aus	—	—	Funktion 8	Funktion f5	Funktion f5
Geräusch: Luftpumpe	—	—	Funktion 1	Funktion f6	Funktion f6
Geräusch: Rangierpiff	—	—	Funktion 5	Funktion f7	Funktion f7
Geräusch: Dampf ablassen	—	—	Funktion 6	Funktion f8	Funktion f8
Geräusch: Kohle schaufeln	—	—	—	Funktion f9	Funktion f9
Geräusch: Schüttelrost	—	—	—	Funktion f10	Funktion f10

Safety Notes





- This locomotive is to be used only with an operating system designed for it (Märklin AC, Märklin Delta, Märklin Digital or Märklin Systems).
- Use only switched mode power supply units and transformers that are designed for your local power system.
- This locomotive must never be supplied with power from more than one transformer.
- Pay close attention to the safety notes in the instructions for your operating system.
- The feeder track must be equipped to prevent interference with radio and television reception, when the locomotive is to be run in conventional operation. The 74046 interference suppression set is to be used for this purpose.
- Do not expose the model to direct sunlight, extreme changes in temperature, or high humidity.
- **WARNING!** Sharp edges and points required for operation.

Important Notes

- The operating instructions and the packaging are a component part of the product and must therefore be kept as well as transferred along with the product to others.
- Please see your authorized Märklin dealer for repairs or spare parts.
- The warranty card included with this product specifies the warranty conditions.
- Disposing: www.maerklin.com/en/imprint.html

Functions

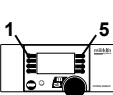
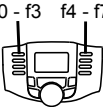
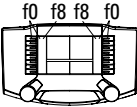
- Recognition of the mode of operation: automatic.
- Addresses that can be set:
1-80 (Control Unit 6021/Mobile Station 60651/652)
1-255 (Central Station 6021x/Mobile Station 60653)
- Address set at the factory: **03**
- Mfx technology for the Mobile Station / Central Station. Name set at the factory: **DB BR 03 1012**
- Adjustable Acceleration delay (ABV).
- Adjustable Braking delay (ABV).
- Adjustable maximum speed.
- Setting the locomotive parameters (address, acceleration/braking delay, maximum speed): with the Control Unit, Mobile Station, Central Station.
- Headlights, changing over with the direction of travel.
- Smoker generator built at the factory.
- Only the train control functions and headlight changeover feature are available in analog operation.

Controllable Functions					 Digital/Systems
Headlights	function/off			Function f0	Function f0
Smoke generator	f1	Function 1	Function 7	Function f1	Function f1
Sound effect: Operating sounds	f2	Function 2	Function 3	Function f2	Function f2
Sound effect: Locomotive whistle	f3	Function 3	Function 4	Function f3	Function f3
ABV, off	f4	Function 4	Function 2	Function f4	Function f4
Sound effect: Squealing brakes off	—	—	Function 8	Function f5	Function f5
Sound effect: Air pump	—	—	Function 1	Function f6	Function f6
Sound effect: Switching whistle	—	—	Function 5	Function f7	Function f7
Sound effect: Blowing off steam	—	—	Function 6	Function f8	Function f8
Sound effect: Coal being shoveled	—	—	—	Function f9	Function f9
Sound effect: Rocker grate	—	—	—	Function f10	Function f10

Remarques importantes sur la sécurité





- La locomotive ne peut être mise en service qu'avec un système d'exploitation adéquat (Märklin AC, Märklin Delta, Märklin Digital ou Märklin Systems).
- Utiliser uniquement des convertisseurs et transformateurs correspondant à la tension du secteur local.
- La locomotive ne peut être alimentée en courant que par une seule source de courant.
- Veuillez impérativement respecter les remarques sur la sécurité décrites dans le mode d'emploi de votre système d'exploitation.
- Pour l'exploitation de la locomotive en mode conventionnel, la voie de raccordement doit être déparasitée. A cet effet, utiliser le set de déparasitage réf. 74046. Le set de déparasitage ne convient pas pour l'exploitation en mode numérique.
- Ne pas exposer le modèle à un ensoleillement direct, à de fortes variations de température ou à un taux d'humidité important.
- **ATTENTION!** Pointes et bords coupants lors du fonctionnement du produit.

Information importante

- La notice d'utilisation et l'emballage font partie intégrante du produit ; ils doivent donc être conservés et, le cas échéant, transmis avec le produit.
- Pour toute réparation ou remplacement de pièces, adressez-vous à votre détaillant-spécialiste Märklin.
- Garantie légale et garantie contractuelle conformément au certificat de garantie ci-joint.
- Elimination : www.maerklin.com/en/imprint.html

Fonctionnement

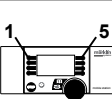
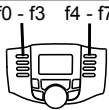
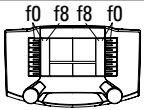
- Détection du mode d'exploitation : automatique.
- Adresses disponibles :
 - 1-80** (Control Unit 6021/Mobile Station 60651/652)
 - 1-255** (Central Station 6021x/Mobile Station 60653)
- Adresse encodée en usine : **03**
- Technologie mfx pour Mobile Station / Central Station. Nom encodée en usine : **DB BR 03 1012**
- Temporisation d'accélération réglable (ABV).
- Temporisation de freinage réglable (ABV).
- Vitesse maximale réglable.
- Réglage des paramètres de la loco (adresse, temporisation accélér.-freinage, vitesse maximale) : via Control Unit, Mobile Station ou Central Station.
- Feux de signalisation avec inversion selon sens de marche.
- Générateur de fumée intégré départ usine.
- En mode d'exploitation analogique, seules les fonctions relatives à la conduite et à l'inversion des feux sont disponibles.

Fonctions commutables				f0 - f3 f4 - f7 	 Digital/Systems
Fanal éclairage	function/off			Fonction f0	Fonction f0
Générateur de fumée	f1	Fonction 1	Fonction 7	Fonction f1	Fonction f1
Bruitage : Bruit d'exploitation	f2	Fonction 2	Fonction 3	Fonction f2	Fonction f2
Bruitage : Sifflet locomotive	f3	Fonction 3	Fonction 4	Fonction f3	Fonction f3
ABV, désactivé	f4	Fonction 4	Fonction 2	Fonction f4	Fonction f4
Bruitage : Grincement de freins désactivé	—	—	Fonction 8	Fonction f5	Fonction f5
Bruitage : Compresseur	—	—	Fonction 1	Fonction f6	Fonction f6
Bruitage : Sifflet pour manœuvre	—	—	Fonction 5	Fonction f7	Fonction f7
Bruitage : Échappement de la vapeur	—	—	Fonction 6	Fonction f8	Fonction f8
Bruitage : Pelletage du charbon	—	—	—	Fonction f9	Fonction f9
Bruitage : Grille à secousses	—	—	—	Fonction f10	Fonction f10

Veiligheidsvoorschriften





- De loc mag alleen met een daarvoor bestemd bedrijfs-systeem (Märklin AC, Märklin Delta, Märklin digitaal of Märklin Systems) gebruikt worden.
- Alleen net-adapters en transformatoren gebruiken waarvan de aangegeven netspanning overeenkomt met de netspanning ter plaatse.
- De loc mag niet vanuit meer dan een stroomvoorziening gelijktijdig gevoed worden.
- Lees ook aandachtig de veiligheidsvoorschriften in de gebruiksaanwijzing van uw bedrijfssysteem.
- Voor het conventionele bedrijf met de loc dient de aansluitrail te worden ontstoort. Hiervoor dient men de ontstoor-set 74046 te gebruiken. Voor het digitale bedrijf is deze ontstoor-set niet geschikt.
- Stel het model niet bloot aan in directe zonnestraling, sterke temperatuurwisselingen of hoge luchtvochtigheid.
- **OPGEPAST!** Functionele scherpe kanten en punten.

Belangrijke aanwijzing

- De gebruiksaanwijzing en de verpakking zijn een bestanddeel van het product en dienen derhalve bewaard en meegeleverd te worden bij het doorgeven van het product.
- Voor reparatie of onderdelen kunt u zich tot uw Märklin handelaar wenden.
- Vrijwaring en garantie overeenkomstig het bijgevoegde garantiebewijs.
- Afdanken: www.maerklin.com/en/imprint.html

Funcities

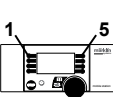
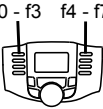
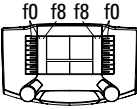
- Herkenning van het bedrijfssysteem: automatisch.
- Instelbare adressen:
 - 1-80** (Control Unit 6021/Mobile Station 60651/652)
 - 1-255** (Central Station 6021x/Mobile Station 60653)
- Vanaf de fabriek ingesteld: **03**
- Mfx-technologie voor het Mobile Station/Central Station. Naam af de fabriek: **DB BR 03 1012**
- Instelbare optrekvertraging (ABV).
- Instelbare afremvertraging (ABV).
- Instelbare maximumsnelheid.
- Instellen van de locomotiefparameters (adres, optrek-/afremvertraging, maximumsnelheid): d.m.v. Control Unit, Mobile Station of Central Station.
- Rijrichtingafhankelijke frontseinen.
- Rookgenerator is af fabriek ingebouwd.
- In analoogbedrijf zijn alleen de rij- en lichtwissel-functies beschikbaar.

Schakelbare functies					 Digital/Systems
Frontsein	function/off			Functie f0	Functie f0
Rookgenerator	f1	Functie 1	Functie 7	Functie f1	Functie f1
Geluid: bedrijfsgeluiden	f2	Functie 2	Functie 3	Functie f2	Functie f2
Geluid: locfluit	f3	Functie 3	Functie 4	Functie f3	Functie f3
ABV, uit	f4	Functie 4	Functie 2	Functie f4	Functie f4
Geluid: piepende remmen uit	—	—	Functie 8	Functie f5	Functie f5
Geluid: luchtpomp	—	—	Functie 1	Functie f6	Functie f6
Geluid: rangeerfluit	—	—	Functie 5	Functie f7	Functie f7
Geluid: stoom afblazen	—	—	Functie 6	Functie f8	Functie f8
Geluid: kolenscheppen	—	—	—	Functie f9	Functie f9
Geluid: schudrooster	—	—	—	Functie f10	Functie f10

Aviso de seguridad

- La locomotora solamente debe funcionar en un sistema de corriente propio (Märklin AC – Märklin Delta – Märklin Digital o Märklin Systems).
- Emplear únicamente fuentes de alimentación conmutadas y transformadores que sean de la tensión de red local.
- La alimentación de la locomotora deberá realizarse desde una sola fuente de suministro.
- Observe bajo todos los conceptos, las medidas de seguridad indicadas en las instrucciones de su sistema de funcionamiento.
- Para el funcionamiento convencional de la locomotora deben suprimirse las interferencias en la vía de conexión de la alimentación. Para ello debe emplearse el set supresor de interferencias 74046. El set supresor de interferencias no es adecuado para el funcionamiento en modo digital.
- No exponer el modelo en miniatura a la radiación solar directa, a oscilaciones fuertes de temperatura o a una humedad del aire elevada.
- **¡ATENCIÓN!** Esquinas y puntas afiladas condicionadas a la función.

Notas importantes





- Las instrucciones de empleo y el embalaje forman parte íntegra del producto y, por este motivo, deben guardarse y entregarse junto con el producto en el caso de venderlo o transmitirlo a otro.
- Para reparaciones o recambios contacte con su proveedor Märklin especializado.
- Responsabilidad y garantía conforme al documento de

garantía que se adjunta.

- Eliminación: www.maerklin.com/en/imprint.html

Funciones

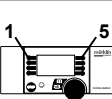
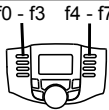
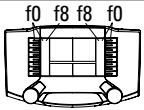
- Reconocimiento del sistema: automático.
- Códigos disponibles:
1-80 (Control Unit 6021/Mobile Station 60651/652)
1-255 (Central Station 6021x/Mobile Station 60653)
- Código de fábrica: **03**
- Tecnología mfx para la Mobile Station/Central Station.
Nombre de fábrica: **DB BR 03 1012**
- Arranque lento variable (ABV).
- Frenado lento variable (ABV).
- Velocidad máxima variable.
- Fijar parámetros de la locomotora (código, arranque y frenado, velocidad máxima):
por el Control Unit, Mobile Station o Central Station.
- Faros frontales dependientes del sentido de marcha.
- Generador de humo montado en fábrica.
- En funcionamiento en modo analógico están disponibles únicamente las funciones de tracción y de alternancia de luces.

Funciones posibles				f0 - f3 f4 - f7 	 Digital/Systems
Señal de cabeza	function/off			Función f0	Función f0
Generador de humo	f1	Función 1	Función 7	Función f1	Función f1
Ruido: ruido de explosión	f2	Función 2	Función 3	Función f2	Función f2
Ruido del silbido de la locomotora	f3	Función 3	Función 4	Función f3	Función f3
ABV, apagado	f4	Función 4	Función 2	Función f4	Función f4
Ruido: Desconectar chirrido de los frenos	—	—	Función 8	Función f5	Función f5
Ruido: Bomba de aire	—	—	Función 1	Función f6	Función f6
Ruido: Silbato de maniobras	—	—	Función 5	Función f7	Función f7
Ruido: Purgar vapor	—	—	Función 6	Función f8	Función f8
Ruido: Cargar carbón con pala	—	—	—	Función f9	Función f9
Ruido: Parrilla vibratoria	—	—	—	Función f10	Función f10

Avvertenze per la sicurezza





- Tale locomotiva deve essere impiegata soltanto con un sistema di funzionamento adeguato per questa (Märklin AC, Märklin Delta, Märklin Digital oppure Märklin Systems).
- Impiegare soltanto alimentatori "switching" e trasformatori che corrispondono alla Vostra tensione di rete locale.
- La locomotiva non deve venire alimentata nello stesso tempo con più di una sorgente di potenza.
- Vogliate prestare assolutamente attenzione alle avvertenze di sicurezza nelle istruzioni di impiego per il Vostro sistema di funzionamento.
- Per il funzionamento tradizionale della locomotiva il binario di alimentazione deve essere protetto dai disturbi. A tale scopo si deve impiegare il corredo antidisturbi 74046. Tale corredo antidisturbi non è adatto per il funzionamento Digital.
- Non esponete tale modello ad alcun irraggiamento solare diretto, a forti escursioni di temperatura oppure a elevata umidità dell'aria.
- **AVVERTENZA!** Per motivi funzionali i bordi e le punte sono spigolosi.

Avvertenze importanti

- Le istruzioni di impiego e l'imballaggio costituiscono un componente sostanziale del prodotto e devono pertanto venire conservati nonché consegnati insieme in caso di ulteriore cessione del prodotto.
- Per le riparazioni o le parti di ricambio, contrattare il rivenditore Märklin.
- Prestazioni di garanzia e garanzia in conformità all'accluso certificato di garanzia.
- Smaltimento: www.maerklin.com/en/imprint.html

Funzioni

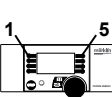
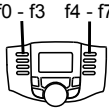
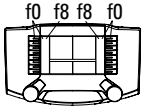
- Riconoscimento del tipo di funzionamento: automatico.
- Indirizzi impostabili:
1-80 (Control Unit 6021/Mobile Station 60651/652)
1-255 (Central Station 6021x/Mobile Station 60653)
- Indirizzo di fabbrica: **03**
- Tecnologia Mfx per Mobile Station / Central Station.
Nome di fabbrica: **DB BR 03 1012**
- Ritardo di avviamento modificabile (ABV).
- Ritardo di frenatura modificabile (ABV).
- Velocità massima modificabile.
- Regolazione dei parametri della locomotiva (indirizzo, ritardo di avviamento/frenatura, velocità massima): tramite Control Unit, Mobile Station oppure Central Station.
- Illuminazione di testa dipendente dalla direzione di marcia.
- Apparato fumogeno incorporato di fabbrica.
- Nel funzionamento analogico si hanno a disposizione solamente le funzioni di marcia e di commutazione dei fanali.

Funzioni commutabili				f0 - f3 f4 - f7 	 Digital/Systems
Segnale di testa	function/off			Funzione f0	Funzione f0
Apparato fumogeno	f1	Funzione 1	Funzione 7	Funzione f1	Funzione f1
Rumore: rumori di esercizio	f2	Funzione 2	Funzione 3	Funzione f2	Funzione f2
Rumore: fischio da locomotiva	f3	Funzione 3	Funzione 4	Funzione f3	Funzione f3
ABV, spento	f4	Funzione 4	Funzione 2	Funzione f4	Funzione f4
Rumore: stridore dei freni escluso	—	—	Funzione 8	Funzione f5	Funzione f5
Rumore: compressore dell'aria	—	—	Funzione 1	Funzione f6	Funzione f6
Rumore: fischio di manovra	—	—	Funzione 5	Funzione f7	Funzione f7
Rumore: scarico del vapore	—	—	Funzione 6	Funzione f8	Funzione f8
Rumore: spalatura del carbone	—	—	—	Funzione f9	Funzione f9
Rumore: griglia a scuotimento	—	—	—	Funzione f10	Funzione f10

Säkerhetsanvisningar





- Loket får endast köras med ett därtill avsett driftsystem (Märklin AC, Märklin Delta, Märklin Digital eller Märklin Systems).
- Använd endast nätadapterar och transformatorer anpassade för det lokala elnätet.
- Loket får inte samtidigt försörjas av mer än en kraftkälla.
- Beakta alltid säkerhetsanvisningarna i bruksanvisningen som hör till respektive driftsystemet.
- När motorvagnens lokdel ska köras med konventionell/ analog drift måste anlutningsskenan vara avstörd. Till detta använder man anslutningsgarnityr 74046 med avstörning och överbelastningsskydd. Avstörningsskyddet får inte användas vid digital körning.
- Modellen får inte utsättas för direkt solljus, häftiga temperaturväxlingar eller hög luftfuktighet.
- **WARNING!** Funktionsbetingade vassa kanter och spetsar.

Viktig information

- Bruksanvisningen och förpackningen är en del av produkten och måste därför sparas och alltid medfölja produkten.
- Kontakta din Märklinfackhandlare för reparationer och reservdelar.
- Garantivillkor framgår av bifogade garantibevis.
- Hantering som avfall: www.maerklin.com/en/imprint.html

Funktioner

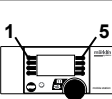
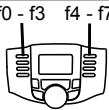
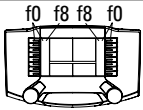
- Driftsättet igenkänns automatiskt.
- Inställbara adresser:
 - 1-80** (Control Unit 6021/Mobile Station 60651/652)
 - 1-255** (Central Station 6021x/Mobile Station 60653)
- Adress från tillverkaren: **03**
- Mfx-teknologi för Mobile Station / Central Station. Namn från tillverkaren: **DB BR 03 1012**
- Accelerationsfördröjning kan ändras (ABV).
- Bromsfördröjning kan ändras (ABV).
- Toppfart kan ändras.
- Inställning av lokparametrar (Adress, acceleration/ bromsfördröjning, toppfart):
Via Control Unit, Mobile Station eller Central Station.
- Körriktningsberoende frontbelysning.
- Lokets rökgenerator är inbyggd av fabriken.
- Vid analog körning är endast den automatiska ljusväxlingsfunktionen tillgänglig.

Kopplingsbara funktioner					 Digital/Systems
Frontstrålkastare	function/off			Funktion f0	Funktion f0
Röksats	f1	Funktion 1	Funktion 7	Funktion f1	Funktion f1
Ljud: Trafikljud	f2	Funktion 2	Funktion 3	Funktion f2	Funktion f2
Ljud: Lokvissla	f3	Funktion 3	Funktion 4	Funktion f3	Funktion f3
ABV, från	f4	Funktion 4	Funktion 2	Funktion f4	Funktion f4
Ljud: Bromsgnissel, från	—	—	Funktion 8	Funktion f5	Funktion f5
Ljud: Luftpump	—	—	Funktion 1	Funktion f6	Funktion f6
Ljud: Rangervissla	—	—	Funktion 5	Funktion f7	Funktion f7
Ljud: Ånga släpps ut	—	—	Funktion 6	Funktion f8	Funktion f8
Ljud: Kol skyfflas	—	—	—	Funktion f9	Funktion f9
Ljud: Roster skakas	—	—	—	Funktion f10	Funktion f10

Vink om sikkerhed





- Lokomotivet må kun bruges med et driftssystem (Märklin AC, Märklin Delta, Märklin Digital eller Märklin Systems), der er beregnet dertil.
- Anvend kun DC-DC-omformere og transformatorer, der passer til den lokale netspænding.
- Lokomotivet må ikke forsynes fra mere end én strømkilde ad gangen.
- Vær under alle omstændigheder opmærksom på de vink om sikkerhed, som findes i brugsanvisningen for Deres driftssystem.
- Ved konventionel drift af lokomotivet skal tilslutningssporet støjdæmpes. Dertil skal anvendes støjdæmpningssættet 74046. Støjdæmpningssættet er ikke egnet til digital drift.
- Modellen må ikke udsættes for direkte sollys, store temperaturudsving eller høj luftfugtighed.
- **ADVARSEL!** Skarpe kanter og spidser pga. funktionen.

Vigtige bemærkninger

- Betjeningsvejledning og emballage hører til produktet og skal derfor gemmes og medfølge, hvis produktet gives videre til andre.
- For reparation eller reservedele bedes De henvende Dem til Deres Märklinforhandler.
- Garanti ifølge vedlagte garantibevis.
- Bortskafning: www.maerklin.com/en/imprint.html

Funktioner

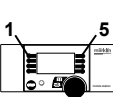
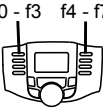
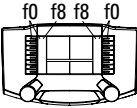
- Registrering af driftsarten: automatisk.
- Indstillelige adresser:
1-80 (Control Unit 6021/Mobile Station 60651/652)
1-255 (Central Station 6021x/Mobile Station 60653)
- Adresse af fabrik: **03**
- Mfx-teknologi til Mobile Station / Central Station.
Navn af fabrik: **DB BR 03 1012**
- Indstillelig kørselsforsinkelse (ABV).
- Indstillelig bremseforsinkelse (ABV).
- Indstillelig maksimalhastighed.
- Indstilling af lokomotivparametrene (adresse, kørsels-/bremseforsinkelse, maksimalhastighed):
Via Control Unit, Mobile Station eller Central Station.
- Køreretningsafhængig frontbelysning.
- Røggenerator indbygget fra fabrikken.
- I analogdrift er det kun køre- og lysskiftefunktionerne, der er tilgængelige.

Styrbare funktioner				f0 - f3 f4 - f7 	 Digital/Systems
Frontsignal	function/off			Funktion f0	Funktion f0
Røggenerator	f1	Funktion 1	Funktion 7	Funktion f1	Funktion f1
Lyd: Driftslyd	f2	Funktion 2	Funktion 3	Funktion f2	Funktion f2
Lyd: Lokomotivfløjte	f3	Funktion 3	Funktion 4	Funktion f3	Funktion f3
ABV, fra	f4	Funktion 4	Funktion 2	Funktion f4	Funktion f4
Lyd: Pibende bremses fra	—	—	Funktion 8	Funktion f5	Funktion f5
Lyd: Luftpumpe	—	—	Funktion 1	Funktion f6	Funktion f6
Lyd: Rangerfløjt	—	—	Funktion 5	Funktion f7	Funktion f7
Lyd: Dampudledning	—	—	Funktion 6	Funktion f8	Funktion f8
Lyd: Skovling af kul	—	—	—	Funktion f9	Funktion f9
Lyd: Rysterist	—	—	—	Funktion f10	Funktion f10

CV (Parameter) • CV (Parameter) • CV (Paramètre) • CV (Parameter) • CV (Parámetro) • CV (Parametro) • CV (Parameter) • CV (Parameter)	CV-Nr.	Wert • Value • Valeur • Waarde • Valor • Valore • Värde • Værdi
Adresse • Address • Adresse • Adres • Código • Indirizzo • Adress • Adresse	01	01 - (80)* 255
Anfahrverzögerung • Acceleration delay • Temporisation accélération • Optrekvertraging • Regulación arranque • Ritardo di avviamento • Igångsättningsreglering • Kørselsforsinkelse	03	01 - (63)* 255
Bremsverzögerung • Braking delay • Temporisation de freinage • Afremvertraging • Frenado lento • Ritardo di frenatura • Bromsfördröjning • Bremseforsinkelse	04	01 - (63)* 255
Höchstgeschwindigkeit • Maximum speed • Vitesse maximale • Maximumsneilheid • Velocidad máxima • Velocità massima • Toppfart • Maksimalhastighed	05	01 - (63)* 255
Rückstellen auf Serienwerte • Reset to series value • Remettre aux valeurs de série • Terugzetten naar serie-instellingen • Restablecer los valores de serie • Ripristinare sui valori di serie • Återställa till standardvärden • Tibagestil til serieværdien	08	08
Lautstärke • Volume • Volume haut-parleur • Volume • Volumen del sonido • Intensità del suono • Ljudstyrka • Lydstyrke	63	01 - (63)* 255

* () = Control Unit 6021 / Mobile Station 60651/60652

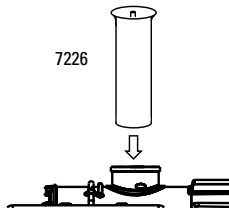

Potentielle Fehlerquellen beim Rauchgenerator

- Der Rauchgenerator darf nur maximal halb mit Rauchöl gefüllt sein.
- Im Rauchgenerator darf sich keine Luftblase befinden.
- Der Anschlussdraht an der Unterseite des Rauchgenerators muss sicheren Kontakt zur Anschlussfeder im Lokomotiv-Fahrgestell besitzen.

Potential Problems with the Smoke Generator

- The smoke generator cannot be filled any more than halfway with smoke fluid.
- There should not be any air bubbles in the smoke generator.
- The connecting wire on the underside of the smoke generator must have a clean contact with the connection field in the locomotive's frame.

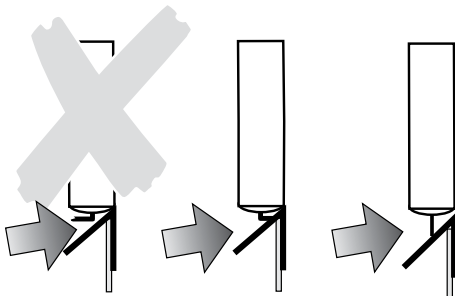
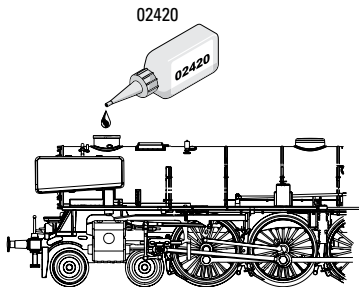

Causes d'erreurs potentielles Avec le générateur fumigène

- Le générateur fumigène ne peut pas être rempli de liquide fumigène au-delà de la moitié du tube.
- Aucune bulle d'air ne peut se trouver dans le générateur fumigène.
- Le câble de raccordement raccordé à la face inférieure du fumigène doit posséder un contact sûr avec le ressort de connexion dans le châssis de la locomotive.

Potentiële storingsoorzaken bij rookgeneratoren

- De rookgenerator mag maximaal half met rookolie gevuld worden.
- In de rookgenerator mag zich geen luchtbel bevinden.
- De aansluitdraad aan de onderzijde van de rookgenerator moet een betrouwbaar contact maken met de contactveer in het locomotief onderstel.

Instrucciones importantes para el buen uso del fumígeno

- Llenar el cartucho solamente hasta la mitad con líquido fumígeno.
- Prestar atención que no se forme una burbuja de aire en el cartucho.
- El hilo tomacorriente de la base debe tener un buen contacto con el resorte que está en el bastidor de la locomotora. Si fuera necesario, ajustar el hilo tomacorriente según la ilustración.

Potenziali origini di guasti nel caso dell'apparato fumogeno

- L'apparato fumogeno come massimo deve essere riempito solamente a metà di olio vaporizzabile.
- Nell'apparato fumogeno non deve trovarsi alcuna bolla d'aria.
- Il conduttore di alimentazione sulla faccia inferiore dell'apparato fumogeno deve possedere un sicuro contatto verso la molla di connessione nel telaio della locomotiva.

Potentiella felkällor på rökgeneratören

- Rökgeneratören får maximalt fyllas till hälften med rökvätska.
- I rökgeneratören får inte finnas någon luftblåsa.
- Anslutningstråden på rökgeneratörens undersida måste ha en säker kontakt med anslutningsfjädern i lokets chassi. I nödfall måste anslutningstråden justeras enligt teckningen bredvid.

Potentielle fejkilder ved røggeneratoren

- Røggeneratoren må maksimalt være halvt fyldt med røgolie.
- Der må ikke være nogen luftbobler i røggeneratoren.
- Der skal være en god og sikker kontakt mellem tilslutningstråden på undersiden af røggeneratoren og tilslutningsfjederen i lokomotivets understel.

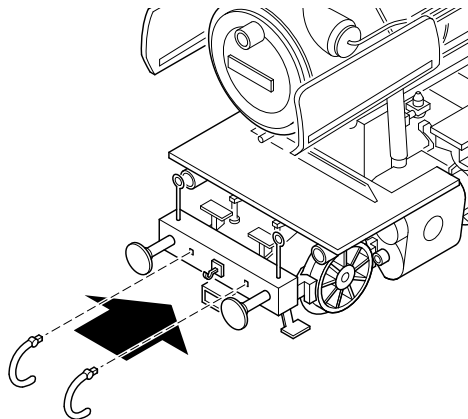
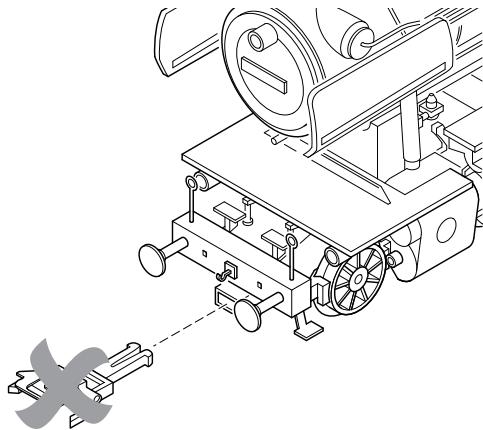

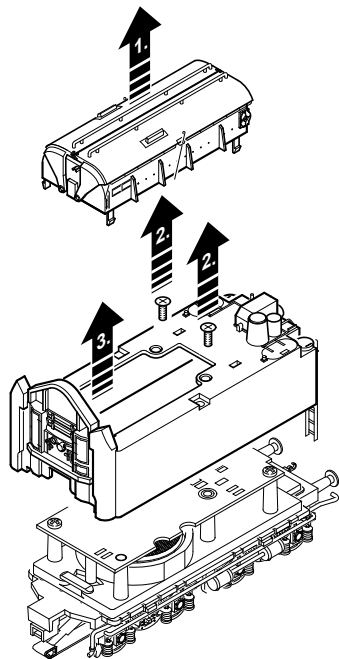
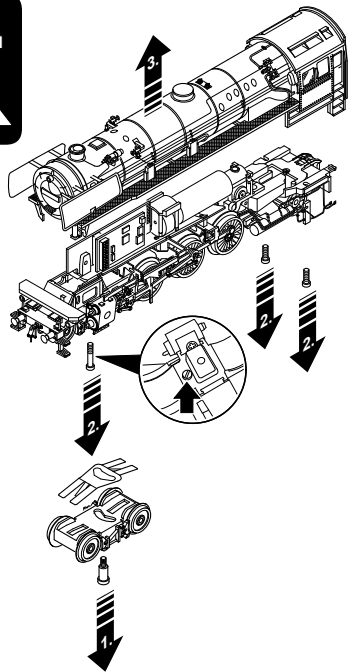

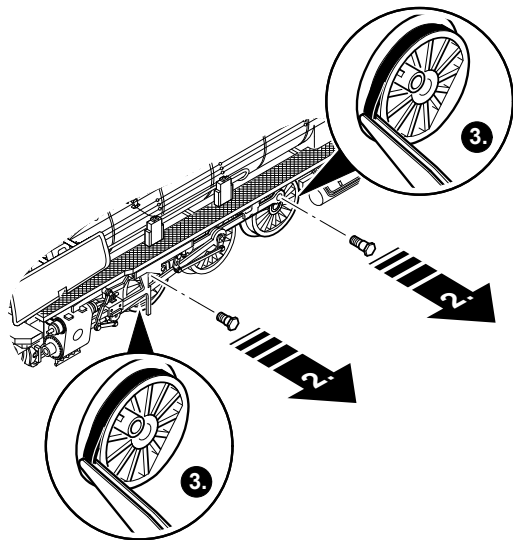
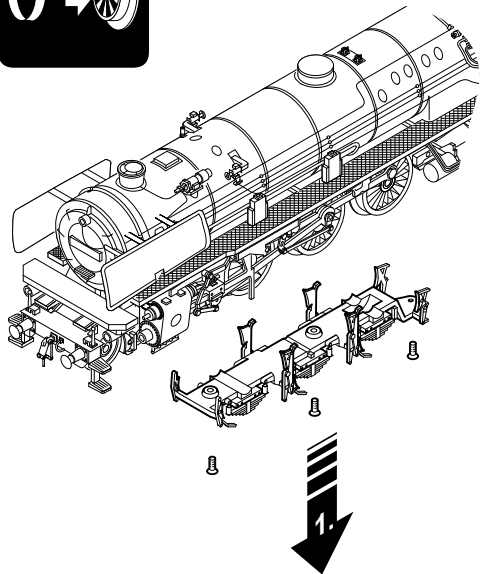
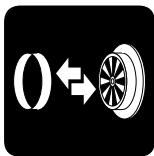

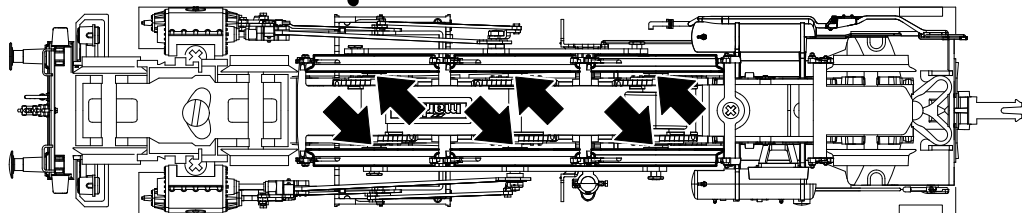
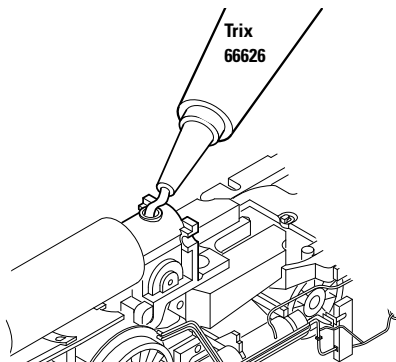

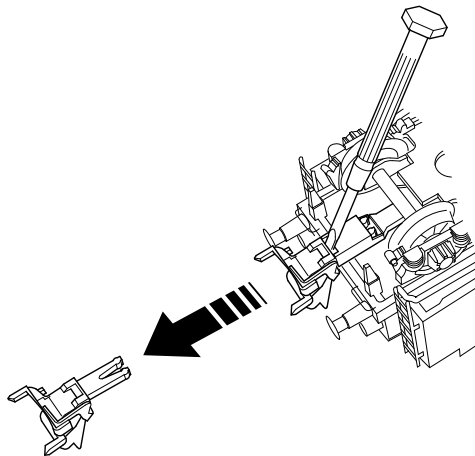
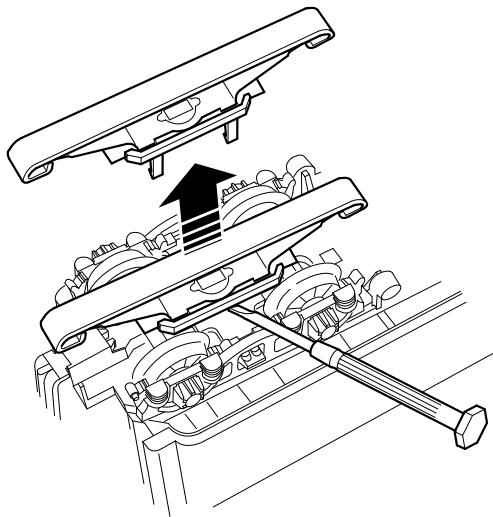
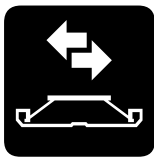

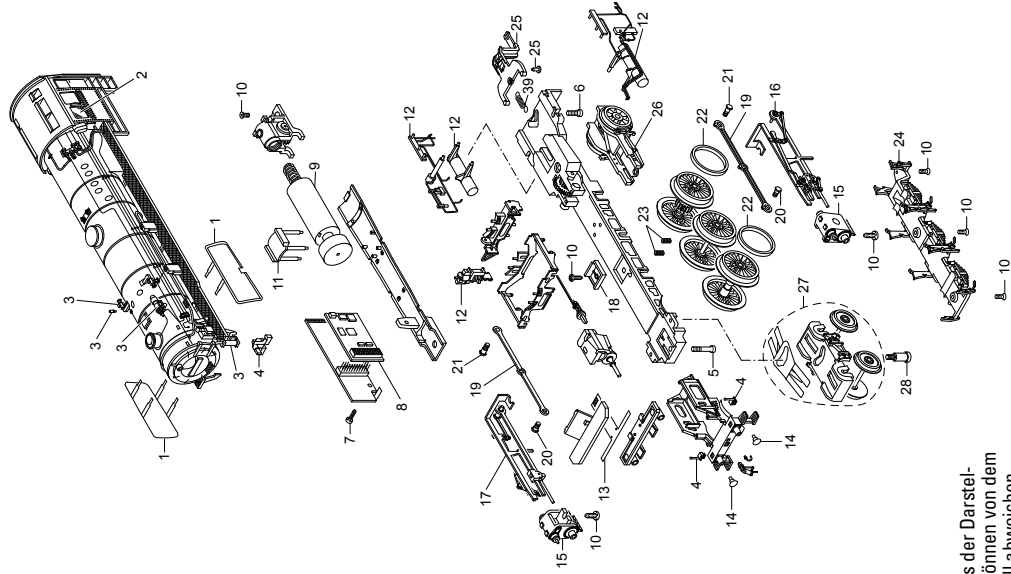

Details der Darstellung können von dem Modell abweichen.

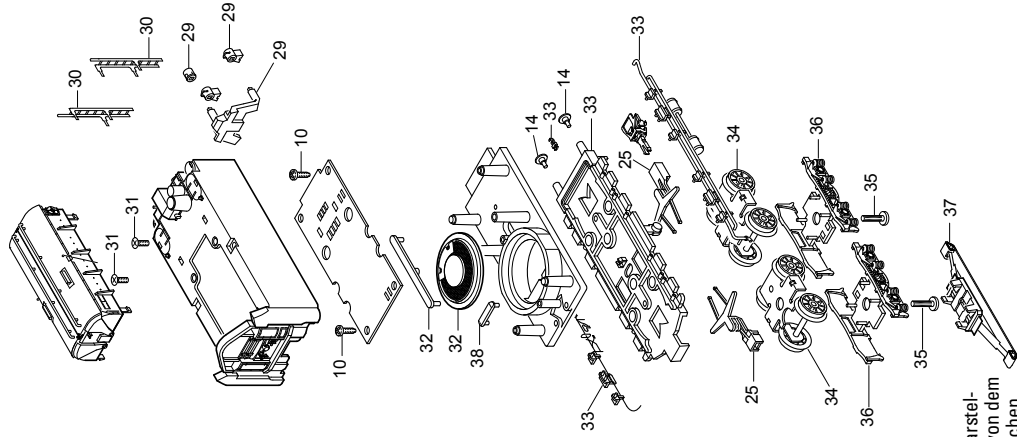

Details der Darstellung können von dem Modell abweichen.

1 Windleitbleche	E178 852	32 Lautsprecher	E180 731
2 Fenster	E162 174	33 Boden	E162 179
3 Steckteile Kessel	E162 173	34 Drehgestell	E163 029
4 Laternen, Lichtkörper	E190 761	35 Schraube	E750 230
5 Schraube	E785 200	36 Drehgestellrahmen	E109 208
6 Schraube	E19 7086 28	37 Schleifer	E206 370
7 Schraube	E786 341	38 Haltebügel	E209 442
8 Decoder	199 071	39 Schaltschieberfeder	7 194
9 Motor	E163 818	Kurzkupplung	E701 630
10 Schraube	E786 750	Bremsleitung	E12 5149 00
11 Abdeckung	E151 211	Kolbenstangenschutzrohr	E219 599
12 Kessel, Leitungen	E162 175		
13 Leiterplatte Stirnbeleuchtung	E151 812		
14 Puffer	E180 625		
15 Zylinder	E180 624		
16 Gestänge links	E150 610		
17 Gestänge rechts	E150 609		
18 Isolierplatte	E253 600		
19 Kuppelstange	E206 133		
20 Schraube	E223 431		
21 Schraube	E499 840		
22 Haftreifen	E656 520		
23 Druckfeder	E214 330		
24 Bremsattrappe	E109 179		
25 Deichsel, Zugstange	E190 762		
26 Laufgestell	E151 210		
27 Drehgestell komplett	E186 081		
28 Schraube	E753 000		
29 Laternen Tender	E162 177		
30 Steckteile Tender	E162 178		
31 Schraube	E786 790		

Hinweis: Einige Teile werden nur ohne oder mit anderer Farbgebung angeboten. Teile, die hier nicht aufgeführt sind, können nur im Rahmen einer Reparatur im Märklin-Reparatur-Service repariert werden.

Due to different legal requirements regarding electro-magnetic compatibility, this item may be used in the USA only after separate certification for FCC compliance and an adjustment if necessary.

Use in the USA without this certification is not permitted and absolves us of any liability. If you should want such certification to be done, please contact us – also due to the additional costs incurred for this.



Gebr. Märklin & Cie. GmbH
Stuttgarter Straße 55 - 57
73033 Göppingen
Germany
www.maerklin.com

www.maerklin.com/en/imprint.html

199562/0813/Ak1Ef
Änderungen vorbehalten
© Gebr. Märklin & Cie. GmbH