



Modell der Serie 1200 NS
37128

Inhaltsverzeichnis:

	Seite
Informationen zum Vorbild	4
Sicherheitshinweise	6
Wichtige Hinweise	6
Funktionen	6
Schaltbare Funktionen	7
Parameter / Register	22
Betriebshinweise	23
Wartung und Instandhaltung	24
Ersatzteile	30

Table of Contents:

	Page
Information about the prototype	4
Safety Notes	8
Important Notes	8
Functions	8
Controllable Functions	9
Parameter / Register	22
Information about operation	23
Service and maintenance	24
Spare Parts	30

Sommaire :

	Page
Informations concernant la locomotive réelle	5
Remarques importantes sur la sécurité	10
Information importante	10
Fonctionnement	10
Fonctions commutables	11
Paramètre / Registre	22
Remarques sur l'exploitation	23
Entretien et maintien	24
Pièces de rechange	30

Inhoudsopgave:

	Pagina
Informatie van het voorbeeld	5
Veiligheidsvoorschriften	12
Belangrijke aanwijzing	12
Functies	12
Schakelbare functies	13
Parameter / Register	22
Opmerkingen over de werking	23
Onderhoud en handhaving	24
Onderdelen	30

Indice de contenido:

	Página
Aviso de seguridad	14
Notas importantes	14
Funciones	14
Funciones posibles	15
Parámetro / Registro	22
Instrucciones de uso	23
El mantenimiento	24
Recambios	30

Indice del contenuto:

	Pagina
Avvertenze per la sicurezza	16
Avvertenze importanti	16
Funzioni	16
Funzioni commutabili	17
Parametro / Registro	22
Avvertenze per il funzionamento	23
Manutenzione ed assistere	24
Pezzi di ricambio	30

Innehållsförteckning:

	Sidan
Säkerhetsanvisningar	18
Viktig information	18
Funktioner	18
Kopplingsbara funktioner	19
Parameter / Register	22
Drifthanvisningar	23
Underhåll och reparation	24
Reservdelar	30

Indholdsfortegnelse:

	Side
Vink om sikkerhed	20
Vigtige bemærkninger	20
Funktioner	20
Styrbare funktioner	21
Parameter / Register	22
Brugsanvisninger	23
Service og reparation	24
Reserve dele	30

Informationen zum Vorbild:

Ab 1951 wurde die von der amerikanischen Firma Baldwin / Westinghouse entwickelte Elektro-Lokomotive der Serie 1200 von Werkspoor in Amsterdam für die niederländischen Eisenbahnen (NS) hergestellt. Mit einer Leistung von 2.200 kW (3.000 PS) und einer Höchstgeschwindigkeit von 135 km/h war diese Lok sowohl vor Personen- als auch vor Güterzügen anzutreffen. Während ihrer Dienstzeit war dieser Loktyp in sehr unterschiedlichen Farbschemen gestaltet. Schon bei der Erstablieferung wurde im Produktionslos die Farbgebung geändert. Eingesetzt wurde die Serie 1200 bis 1998 bei der NS. Nach der Ausmusterung setzten einige Modelle ihren Dienst unter privater Leitung fort.

Information about the Prototype:

The class 1200 electric locomotive developed by the American firms Baldwin / Westinghouse was built starting in 1951 by Werkspoor in Amsterdam for the Dutch State Railways (NS). With a power output of 2,200 kilowatts or 3,000 horsepower and a maximum speed of 135 km/h or 84 mph, this locomotive was used for both passenger and freight trains. During its service life this class of locomotive was painted in very different color schemes. The color scheme was already being changed during the first production run. The class 1200 was used on the NS until 1998. After being retired from the NS, several units continued to work in private service.

Informations concernant la locomotive réelle :

La locomotive électrique de la série 1200, conçue par la firme américaine Baldwin / Westinghouse, fut construite à partir de 1951 pour les chemins de fer néerlandais (NS) par Werkspoor à Amsterdam. Avec une puissance de 2 200 kW (3000 ch) et une vitesse maximale de 135 km/h, cette locomotive remorquait aussi bien des trains voyageurs que des trains marchandises. Ce type de locomotive connut des livrées diverses et variées tout au long de son service. Dès la première livraison, la couleur fut déjà modifiée dans le lot de production. La série 1200 fut utilisée par les NS jusqu'en 1998. Après leur réforme, quelques unités poursuivirent leur service dans le secteur privé.

Informatie van het voorbeeld:

Vanaf 1951 werd de elektrische locomotief serie 1200 die door de Amerikaanse firma Baldwin / Westinghouse ontwikkeld was, door Werkspoor in Amsterdam voor de Nederlandse Spoorwegen (NS) gefabriceerd. Met een vermogen van 2.200 kW (3.000 pk) en een maximumsnelheid van 135 km/h was deze loc zowel voor reizigers- als goederentreinen aan te treffen. Gedurende hun diensttijd was dit loctype in diverse kleurenschema's uitgevoerd. Reeds bij de eerste aflevering werd de kleurstelling in de verschillende delen van de productie veranderd. De serie 1200 werd bij de NS tot 1998 ingezet. Na de buitendienststelling zetten enkele exemplaren hun dienst bij particuliere maatschappijen voort.

Sicherheitshinweise









- Die Lok darf nur mit einem dafür bestimmten Betriebssystem (Märklin Wechselstrom, Märklin Delta, Märklin Digital oder Märklin Systems) eingesetzt werden.
- Nur Schaltnetzteile/Transformatoren verwenden, die Ihrer örtlichen Netzspannung entsprechen.
- Die Lok darf nur aus einer Leistungsquelle versorgt werden.
- Beachten Sie unbedingt die Sicherheitshinweise in der Bedienungsanleitung zu Ihrem Betriebssystem.
- Für den konventionellen Betrieb der Lok muss das Anschlussgleis entstört werden. Dazu ist das Entstörset 74046 zu verwenden. Für Digitalbetrieb ist das Entstörset nicht geeignet.
- **ACHTUNG!** Funktionsbedingte scharfe Kanten und Spitzen.
- Setzen Sie das Modell keiner direkten Sonneneinstrahlung, starken Temperaturschwankungen oder hoher Luftfeuchtigkeit aus.

Wichtige Hinweise

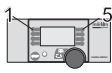
- Die Bedienungsanleitung und die Verpackung sind Bestandteile des Produktes und müssen deshalb aufbewahrt sowie bei Weitergabe des Produktes mitgegeben werden.
- Für Reparaturen oder Ersatzteile wenden Sie sich bitte an Ihren Märklin-Fachhändler.
- Gewährleistung und Garantie gemäß der beiliegenden Garantieurkunde.
- <http://www.maerklin.com/en/imprint.html>

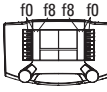
Funktionen

- Erkennung der Betriebsart: automatisch.
- Einstellbare Adressen:
 - 1-80** (Control Unit 6021/Mobile Station 60651/652)
 - 1-255** (Central Station 6021x/Mobile Station 60653)
- Adresse ab Werk: **12**
- Mfx-Technologie für Mobile Station / Central Station.
Name ab Werk: **Serie 1252 EETC**
- Veränderbare Anfahrverzögerung (ABV).
- Veränderbare Bremsverzögerung (ABV).
- Veränderbare Höchstgeschwindigkeit.
- Einstellen der Lokparameter (Adresse, Anfahr-/Bremsverzögerung, Höchstgeschwindigkeit): über Control Unit, Mobile Station oder Central Station.
- Fahrtrichtungsabhängige Stirnbeleuchtung.
- Im Analogbetrieb stehen nur die Fahr- und Lichtwechselfunktionen zur Verfügung.

Schaltbare Funktionen					 Digital/Systems
Spitzensignal	function/off			Funktion f0	Funktion f0
Geräusch: Bahnofsansage	f1	Funktion 1	Funktion 3	Funktion f1	Funktion f1
Betriebsgeräusch	f2	Funktion 2	Funktion 2	Funktion f2	Funktion f2
Geräusch: Signalhorn 1 lang	f3	Funktion 3	Funktion 6	Funktion f3	Funktion f3
ABV, aus	f4	Funktion 4	Funktion 4	Funktion f4	Funktion f4
Geräusch: Bremsenquietschen aus	—	—	Funktion 5	Funktion f5	Funktion f5
Spitzensignal Führerstand 2 aus*	—	—	Funktion 1	Funktion f6	Funktion f6
Geräusch: Schaffnerpfeif	—	—	Funktion 7	Funktion f7	Funktion f7
Spitzensignal Führerstand 1 aus*	—	—	Funktion 8	Funktion f8	Funktion f8
Geräusch: Kompressor	—	—	—	Funktion f9	Funktion f9
Geräusch: Lüfter	—	—	—	Funktion f10	Funktion f10
Geräusch: Signalhorn 2	—	—	—	Funktion f11	Funktion f11
Rangiergang	—	—	—	Funktion f12	Funktion f12
Rangierlicht doppel A	—	—	 + f1 + f8	f0 + f6 + f8	f0 + f6 + f8

* nur in Verbindung mit Spitzensignal

Safety Notes









- This locomotive is to be used only with an operating system designed for it (Märklin AC, Märklin Delta, Märklin Digital or Märklin Systems).
- Use only switched mode power supply units and transformers that are designed for your local power system.
- This locomotive must never be supplied with power from more than one transformer.
- Pay close attention to the safety notes in the instructions for your operating system.
- The feeder track must be equipped to prevent interference with radio and television reception, when the locomotive is to be run in conventional operation. The 74046 interference suppression set is to be used for this purpose.
- **WARNING!** Sharp edges and points required for operation.
- Do not expose the model to direct sunlight, extreme changes in temperature, or high humidity.

Important Notes

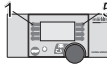
- The operating instructions and the packaging are a component part of the product and must therefore be kept as well as transferred along with the product to others.
- Please see your authorized Märklin dealer for repairs or spare parts.
- The warranty card included with this product specifies the warranty conditions.
- <http://www.maerklin.com/en/imprint.html>

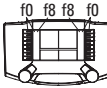
Functions

- Recognition of the mode of operation: automatic.
- Addresses that can be set:
 - 1-80** (Control Unit 6021/Mobile Station 60651/652)
 - 1-255** (Central Station 6021x/Mobile Station 60653)
- Address set at the factory: **12**
- Mfx technology for the Mobile Station / Central Station. Name set at the factory: **Serie 1252 EETC**
- Adjustable Acceleration delay (ABV).
- Adjustable Braking delay (ABV).
- Adjustable maximum speed.
- Setting the locomotive parameters (address, acceleration/braking delay, maximum speed): with the Control Unit, Mobile Station, Central Station.
- Headlights, changing over with the direction of travel.
- Only the train control functions and headlight changeover feature are available in analog operation.

Controllable Functions					 Digital/Systems
Headlights	function/off			Function f0	Function f0
Sound effect: Station announcements	f1	Function 1	Function 3	Function f1	Function f1
Locomotive operating sounds	f2	Function 2	Function 2	Function f2	Function f2
Sound effect: Long horn blast 1	f3	Function 3	Function 6	Function f3	Function f3
ABV, off	f4	Function 4	Function 4	Function f4	Function f4
Sound effect: Squealing brakes off	—	—	Function 5	Function f5	Function f5
Headlights Engineer's Cab 2 off*	—	—	Function 1	Function f6	Function f6
Sound effect: Conductor whistle	—	—	Function 7	Function f7	Function f7
Headlights Engineer's Cab 1 off*	—	—	Function 8	Function f8	Function f8
Sound effect: compressor	—	—	—	Function f9	Function f9
Sound effect: Blower	—	—	—	Function f10	Function f10
Sound effect: Horn 2	—	—	—	Function f11	Function f11
Low speed switching range	—	—	—	Function f12	Function f12
Double A switching light	—	—	 + f1 + f8	f0 + f6 + f8	f0 + f6 + f8

* only in conjunction with Headlights/marker lights

Remarques importantes sur la sécurité

- La locomotive ne peut être mise en service qu'avec un système d'exploitation adéquat (Märklin AC, Märklin Delta, Märklin Digital ou Märklin Systems).
- Utiliser uniquement des convertisseurs et transformateurs correspondant à la tension du secteur local.
- La locomotive ne peut être alimentée en courant que par une seule source de courant.
- Veuillez impérativement respecter les remarques sur la sécurité décrites dans le mode d'emploi de votre système d'exploitation.
- Pour l'exploitation de la locomotive en mode conventionnel, la voie de raccordement doit être déparasitée. A cet effet, utiliser le set de déparasitage réf. 74046. Le set de déparasitage ne convient pas pour l'exploitation en mode numérique.
- **ATTENTION!** Pointes et bords coupants lors du fonctionnement du produit.
- Ne pas exposer le modèle à un ensoleillement direct, à de fortes variations de température ou à un taux d'humidité important.









Information importante

- La notice d'utilisation et l'emballage font partie intégrante du produit ; ils doivent donc être conservés et, le cas échéant, transmis avec le produit.
- Pour toute réparation ou remplacement de pièces, adressez-vous à votre détaillant-spécialiste Märklin.

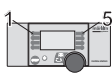
- Garantie légale et garantie contractuelle conformément au certificat de garantie ci-joint.
- <http://www.maerklin.com/en/imprint.html>

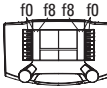
Fonctionnement

- Détection du mode d'exploitation : automatique.
- Adresses disponibles :
 - 1-80** (Control Unit 6021/Mobile Station 60651/652)
 - 1-255** (Central Station 6021x/Mobile Station 60653)
- Adresse encodée en usine : **12**
- Technologie mfx pour Mobile Station / Central Station.
Nom encodée en usine : **Serie 1252 EETC**
- Temporisation d'accélération réglable (ABV).
- Temporisation de freinage réglable (ABV).
- Vitesse maximale réglable.
- Réglage des paramètres de la loco (adresse, temporisation accélér.-freinage, vitesse maximale) : via Control Unit, Mobile Station ou Central Station.
- Feux de signalisation avec inversion selon sens de marche.
- En mode d'exploitation analogique, seules les fonctions relatives à la conduite et à l'inversion des feux sont disponibles.

Fonctions commutables					 Digital/Systems
Fanal éclairage	function/off			Fonction f0	Fonction f0
Bruitage : Annonce en gare	f1	Fonction 1	Fonction 3	Fonction f1	Fonction f1
Bruit de roulement	f2	Fonction 2	Fonction 2	Fonction f2	Fonction f2
Bruitage : trompe 1, signal long	f3	Fonction 3	Fonction 6	Fonction f3	Fonction f3
ABV, désactivé	f4	Fonction 4	Fonction 4	Fonction f4	Fonction f4
Bruitage : Grincement de freins désactivé	—	—	Fonction 5	Fonction f5	Fonction f5
Fanal cabine de conduite 2 éteint*	—	—	Fonction 1	Fonction f6	Fonction f6
Bruitage : Sifflet Contrôleur	—	—	Fonction 7	Fonction f7	Fonction f7
Fanal cabine de conduite 1 éteint*	—	—	Fonction 8	Fonction f8	Fonction f8
Bruitage : Compresseur	—	—	—	Fonction f9	Fonction f9
Bruitage : ventilateur	—	—	—	Fonction f10	Fonction f10
Bruitage : trompe 2, signal	—	—	—	Fonction f11	Fonction f11
Vitesse de manœuvre	—	—	—	Fonction f12	Fonction f12
Feu de manœuvre double A	—	—	 + f1 + f8	f0 + f6 + f8	f0 + f6 + f8

* Uniquement en combinaison avec Fanal éclairage

Veiligheidsvoorschriften









- De loc mag alleen met een daarvoor bestemd bedrijfs-systeem (Märklin AC, Märklin Delta, Märklin digitaal of Märklin Systems) gebruikt worden.
- Alleen net-adapters en transformatoren gebruiken waarvan de aangegeven netspanning overeenkomt met de netspanning ter plaatse.
- De loc mag niet vanuit meer dan één stroomvoorziening gelijktijdig gevoed worden.
- Lees ook aandachtig de veiligheidsvoorschriften in de gebruiksaanwijzing van uw bedrijfssysteem.
- Voor het conventionele bedrijf met de loc dient de aansluitrail te worden ontstoort. Hiervoor dient men de ontstoor-set 74046 te gebruiken. Voor het digitale bedrijf is deze ontstoor-set niet geschikt.
- **OPGEPAST!** Functionele scherpe kanten en punten.
- Stel het model niet bloot aan in directe zonnestraling, sterke temperatuurwisselingen of hoge luchtvochtigheid.

Belangrijke aanwijzing

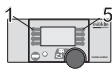
- De gebruiksaanwijzing en de verpakking zijn een bestanddeel van het product en dienen derhalve bewaard en meegeleverd te worden bij het doorgeven van het product.
- Voor reparatie of onderdelen kunt u zich tot uw Märklin handelaar wenden.
- Vrijwaring en garantie overeenkomstig het bijgevoegde-garantiebewijs.
- <http://www.maerklin.com/en/imprint.html>

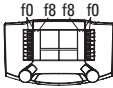
Funcities

- Herkenning van het bedrijfssysteem: automatisch.
- Instelbare adressen:
1-80 (Control Unit 6021/Mobile Station 60651/652)
1-255 (Central Station 6021x/Mobile Station 60653)
- Vanaf de fabriek ingesteld: **12**
- Mfx-technologie voor het Mobile Station/Central Station. Naam af de fabriek: **Serie 1252 EETC**
- Instelbare optrekvertraging (ABV).
- Instelbare afremvertraging (ABV).
- Instelbare maximumsnelheid.
- Instellen van de locomotiefparameters (adres, optrek-/afremvertraging, maximumsnelheid): d.m.v. Control Unit, Mobile Station of Central Station.
- Rijrichtingafhankelijke frontseinen.
- In analoogbedrijf zijn alleen de rij- en lichtwissel-functies beschikbaar.

Schakelbare functies					 Digital/Systems
Frontsein	function/off			Functie f0	Functie f0
Geluid: stationsomroep	f1	Functie 1	Functie 3	Functie f1	Functie f1
Rijgeluiden	f2	Functie 2	Functie 2	Functie f2	Functie f2
Geluid: signaalhoorn 1 lang	f3	Functie 3	Functie 6	Functie f3	Functie f3
ABV, uit	f4	Functie 4	Functie 4	Functie f4	Functie f4
Geluid: piepende remmen uit	—	—	Functie 5	Functie f5	Functie f5
Frontsein cabine 2 uit*	—	—	Functie 1	Functie f6	Functie f6
Geluid: conducteurfluit	—	—	Functie 7	Functie f7	Functie f7
Frontsein cabine 1 uit*	—	—	Functie 8	Functie f8	Functie f8
Geluid: compressor	—	—	—	Functie f9	Functie f9
Geluid: ventilator	—	—	—	Functie f10	Functie f10
Geluid: signaalhoorn 2	—	—	—	Functie f11	Functie f11
Rangeerstand	—	—	—	Functie f12	Functie f12
Rangeerlicht dubbel A	—	—	 + f1 + f8	f0 + f6 + f8	f0 + f6 + f8

* alleen in combinatie met Frontsein

Aviso de seguridad

- La locomotora solamente debe funcionar en un sistema de corriente propio (Märklin AC – Märklin Delta – Märklin Digital o Märklin Systems).
- Emplear únicamente fuentes de alimentación conmutadas y transformadores que sean de la tensión de red local.
- La alimentación de la locomotora deberá realizarse desde una sola fuente de suministro.
- Observe bajo todos los conceptos, las medidas de seguridad indicadas en las instrucciones de su sistema de funcionamiento.
- Para el funcionamiento convencional de la locomotora deben suprimirse las interferencias en la vía de conexión de la alimentación. Para ello debe emplearse el set supresor de interferencias 74046. El set supresor de interferencias no es adecuado para el funcionamiento en modo digital.
- ¡**ATENCIÓN!** Esquinas y puntas afiladas condicionadas a la función.
- No exponer el modelo en miniatura a la radiación solar directa, a oscilaciones fuertes de temperatura o a una humedad del aire elevada.









Notas importantes

- Las instrucciones de empleo y el embalaje forman parte íntegra del producto y, por este motivo, deben guardarse y entregarse junto con el producto en el caso de venderlo o transmitirlo a otro.

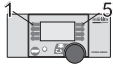
- Para reparaciones o recambios contacte con su proveedor Märklin especializado.
- Responsabilidad y garantía conforme al documento de garantía que se adjunta.
- <http://www.maerklin.com/en/imprint.html>

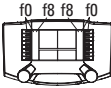
Funciones

- Reconocimiento del sistema: automático.
- Códigos disponibles:
 - 1-80** (Control Unit 6021/Mobile Station 60651/652)
 - 1-255** (Central Station 6021x/Mobile Station 60653)
- Código de fábrica: **12**
- Tecnología mfx para la Mobile Station/Central Station.
Nombre de fábrica: **Serie 1252 EETC**
- Arranque lento variable (ABV).
- Frenado lento variable (ABV).
- Velocidad máxima variable.
- Fijar parámetros de la locomotora (código, arranque y frenado, velocidad máxima): por el Control Unit, Mobile Station o Central Station.
- Faros frontales dependientes del sentido de marcha.
- En funcionamiento en modo analógico están disponibles únicamente las funciones de tracción y de alternancia de luces.

Funciones posibles					 Digital/Systems
Señal de cabeza	function/off			Función f0	Función f0
Ruido: Locución hablada en estaciones	f1	Función 1	Función 3	Función f1	Función f1
Ruido de marcha	f2	Función 2	Función 2	Función f2	Función f2
Ruido: Bocina de aviso 1, señal larga	f3	Función 3	Función 6	Función f3	Función f3
ABV, apagado	f4	Función 4	Función 4	Función f4	Función f4
Ruido: Desconectar chirrido de los frenos	—	—	Función 5	Función f5	Función f5
Señal de cabeza cabina de conducción 2 apagada*	—	—	Función 1	Función f6	Función f6
Ruido: Silbato de Revisor	—	—	Función 7	Función f7	Función f7
Señal de cabeza cabina de conducción 1 apagada*	—	—	Función 8	Función f8	Función f8
Ruido: Compresor	—	—	—	Función f9	Función f9
Ruido: Ventilador	—	—	—	Función f10	Función f10
Ruido: Bocina de aviso 2	—	—	—	Función f11	Función f11
Maniobrar (velocidad lenta)	—	—	—	Función f12	Función f12
Luces de maniobra doble A	—	—	 + f1 + f8	f0 + f6 + f8	f0 + f6 + f8

* Sólo junto con Señal de cabeza

Avvertenze per la sicurezza

- Tale locomotiva deve essere impiegata soltanto con un sistema di funzionamento adeguato per questa (Märklin AC, Märklin Delta, Märklin Digital oppure Märklin Systems).
- Impiegare soltanto alimentatori “switching” e trasformatori che corrispondono alla Vostra tensione di rete locale.
- La locomotiva non deve venire alimentata nello stesso tempo con più di una sorgente di potenza.
- Vogliate prestare assolutamente attenzione alle avvertenze di sicurezza nelle istruzioni di impiego per il Vostro sistema di funzionamento.
- Per il funzionamento tradizionale della locomotiva binario di alimentazione deve essere protetto dai disturbi. A tale scopo si deve impiegare il corredo antidisturbi 74046. Tale corredo antidisturbi non è adatto per il funzionamento Digital.
- **AVVERTENZA!** Per motivi funzionali i bordi e le punte sono spigolosi.
- Non esponete tale modello ad alcun irraggiamento solare diretto, a forti escursioni di temperatura oppure a elevata umidità dell'aria.

Avvertenze importanti

- Le istruzioni di impiego e l'imballaggio costituiscono un componente sostanziale del prodotto e devono pertanto venire conservati nonché consegnati insieme in caso di ulteriore cessione del prodotto.

- Per le riparazioni o le parti di ricambio, contrattare il rivenditore Märklin.
- Prestazioni di garanzia e garanzia in conformità all'accluso certificato di garanzia.
- <http://www.maerklin.com/en/imprint.html>

Funzioni

- Riconoscimento del tipo di funzionamento: automatico.
- Indirizzi impostabili:
 - 1-80** (Control Unit 6021/Mobile Station 60651/652)
 - 1-255** (Central Station 6021x/Mobile Station 60653)
- Indirizzo di fabbrica: **12**
- Tecnologia Mfx per Mobile Station / Central Station.
Nome di fabbrica: **Serie 1252 EETC**
- Ritardo di avviamento modificabile (ABV).
- Ritardo di frenatura modificabile (ABV).
- Velocità massima modificabile.
- Regolazione dei parametri della locomotiva (indirizzo, ritardo di avviamento/frenatura, velocità massima): tramite Control Unit, Mobile Station oppure Central Station.
- Illuminazione di testa dipendente dalla direzione di marcia.
- Nel funzionamento analogico si hanno a disposizione solamente le funzioni di marcia e di commutazione dei fanali.

Funzioni commutabili					 Digital/Systems
Segnale di testa	function/off			Funzione f0	Funzione f0
Rumore: annuncio di stazione	f1	Funzione 1	Funzione 3	Funzione f1	Funzione f1
Rumore di marcia	f2	Funzione 2	Funzione 2	Funzione f2	Funzione f2
Rumore: tromba di segnalazione 1 lunga	f3	Funzione 3	Funzione 6	Funzione f3	Funzione f3
ABV, spento	f4	Funzione 4	Funzione 4	Funzione f4	Funzione f4
Rumore: stridore dei freni escluso	—	—	Funzione 5	Funzione f5	Funzione f5
Segnale di testa cabina di guida 2 spento*	—	—	Funzione 1	Funzione f6	Funzione f6
Rumore: fischio di capotreno	—	—	Funzione 7	Funzione f7	Funzione f7
Segnale di testa cabina di guida 1 spento*	—	—	Funzione 8	Funzione f8	Funzione f8
Rumore: compressore	—	—	—	Funzione f9	Funzione f9
Rumore: ventilatori	—	—	—	Funzione f10	Funzione f10
Rumore: tromba di segnalazione 2	—	—	—	Funzione f11	Funzione f11
Andatura da manovra	—	—	—	Funzione f12	Funzione f12
Fanale di manovra a doppia A	—	—	 + f1 + f8	f0 + f6 + f8	f0 + f6 + f8

* soltanto in abbinamento con Segnale di testa

Säkerhetsanvisningar









- Loket får endast köras med ett därtill avsett driftsystem (Märklin AC, Märklin Delta, Märklin Digital eller Märklin Systems).
- Använd endast nätadapterar och transformatorer anpassade för det lokala elnätet.
- Loket får inte samtidigt försörjas av mer än en kraftkälla.
- Beakta alltid säkerhetsanvisningarna i bruksanvisningen som hör till respektive driftsystemet.
- När motorvagnens lokdel ska köras med konventionell/ analog drift måste anslutningsskenan vara avstörd. Till detta använder man anslutningsgarnityr 74046 med avstörning och överbelastningsskydd. Avstörningsskyddet får inte användas vid digital körning.
- **WARNING!** Funktionsbetingade vassa kanter och spetsar.
- Modellen får inte utsättas för direkt solljus, häftiga temperaturväxlingar eller hög luftfuktighet.

Viktig information

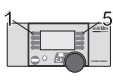
- Bruksanvisningen och förpackningen är en del av produkten och måste därför sparas och alltid medfölja produkten.
- Kontakta din Märklinfackhandlare för reparationer och reservdelar.
- Garantivillkor framgår av bifogade garantibevis.
- <http://www.maerklin.com/en/imprint.html>

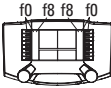
Funktioner

- Driftsättet igenkänns automatiskt.
- Inställbara adresser:
1-80 (Control Unit 6021/Mobile Station 60651/652)
1-255 (Central Station 6021x/Mobile Station 60653)
- Adress från tillverkaren: **12**
- Mfx-teknologi för Mobile Station / Central Station.
Namn från tillverkaren: **Serie 1252 EETC**
- Accelerationsfördröjning kan ändras (ABV).
- Bromsfördröjning kan ändras (ABV).
- Toppfart kan ändras.
- Inställning av lokparametrar (Adress, acceleration/ bromsfördröjning, toppfart): Via Control Unit, Mobile Station eller Central Station.
- Körriktningsberoende frontbelysning.
- Vid analog körning är endast den automatiska ljusväxlingsfunktionen tillgänglig.

Kopplingsbara funktioner					 Digital/Systems
Frontstrålkastare	function/off			Funktion f0	Funktion f0
Ljud: Stationsutrop	f1	Funktion 1	Funktion 3	Funktion f1	Funktion f1
Körljud	f2	Funktion 2	Funktion 2	Funktion f2	Funktion f2
Ljud: Signalhorn 1 långt	f3	Funktion 3	Funktion 6	Funktion f3	Funktion f3
ABV, från	f4	Funktion 4	Funktion 4	Funktion f4	Funktion f4
Ljud: Bromsgnissel, från	—	—	Funktion 5	Funktion f5	Funktion f5
Frontstrålkastare Förrarhytt 2 släckta*	—	—	Funktion 1	Funktion f6	Funktion f6
Ljud: Konduktörvissla	—	—	Funktion 7	Funktion f7	Funktion f7
Frontstrålkastare Förrarhytt 1 släckta*	—	—	Funktion 8	Funktion f8	Funktion f8
Ljud: Kompressor	—	—	—	Funktion f9	Funktion f9
Ljud: Fläktar	—	—	—	Funktion f10	Funktion f10
Ljud: Signalhorn 2	—	—	—	Funktion f11	Funktion f11
Rangerkörning	—	—	—	Funktion f12	Funktion f12
Rangerljus dubbel A	—	—	 + f1 + f8	f0 + f6 + f8	f0 + f6 + f8

* Endast tillsammans med Frontstrålkastare

Vink om sikkerhed









- Lokomotivet må kun bruges med et driftssystem (Märklin AC, Märklin Delta, Märklin Digital eller Märklin Systems), der er beregnet dertil.
- Anvend kun DC-DC-omformere og transformatorer, der passer til den lokale netspænding.
- Lokomotivet må ikke forsynes fra mere end én strømkilde ad gangen.
- Vær under alle omstændigheder opmærksom på de vink om sikkerhed, som findes i brugsanvisningen for Deres driftssystem.
- Ved konventionel drift af lokomotivet skal tilslutningsspolet støjdamper. Dertil skal anvendes støjdemperingssættet 74046. Støjdemperingssættet er ikke egnet til digital drift.
- **ADVARSEL!** Skarpe kanter og spidser pga. funktionen.
- Modellen må ikke udsættes for direkte sollys, store temperaturudsving eller høj luftfugtighed.

Vigtige bemærkninger

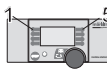
- Betjeningsvejledning og emballage hører til produktet og skal derfor gemmes og medfølge, hvis produktet gives videre til andre.
- For reparation eller reservedele bedes De henvende Dem til Deres Märklinforhandler.
- Garanti ifølge vedlagte garantibevis.
- <http://www.maerklin.com/en/imprint.html>

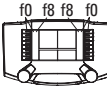
Funktioner

- Registrering af driftsarten: automatisk.
- Indstillelige adresser:
1-80 (Control Unit 6021/Mobile Station 60651/652)
1-255 (Central Station 6021x/Mobile Station 60653)
- Adresse af fabrik: **12**
- Mfx-teknologi til Mobile Station / Central Station.
Navn af fabrik: **Serie 1252 EETC**
- Indstillelig kørselsforsinkelse (ABV).
- Indstillelig bremseforsinkelse (ABV).
- Indstillelig maksimalhastighed.
- Indstilling af lokomotivparametrene (adresse, kørsels-/bremseforsinkelse, maksimalhastighed): Via Control Unit, Mobile Station eller Central Station.
- Køreretningsafhængig frontbelysning.
- I analogdrift er det kun køre- og lyskiftefunktionerne, der er tilgængelige.

Styrbare funktioner					 Digital/Systems
Frontsignal	function/off			Funktion f0	Funktion f0
Lyd: Banegårdsmeddelelse	f1	Funktion 1	Funktion 3	Funktion f1	Funktion f1
Kørelyd	f2	Funktion 2	Funktion 2	Funktion f2	Funktion f2
Lyd: Signalhorn 1 langt	f3	Funktion 3	Funktion 6	Funktion f3	Funktion f3
ABV, fra	f4	Funktion 4	Funktion 4	Funktion f4	Funktion f4
Lyd: Pibende bremses fra	—	—	Funktion 5	Funktion f5	Funktion f5
Frontsignal, førerstand 2 slukket*	—	—	Funktion 1	Funktion f6	Funktion f6
Lyd: Billetkontrollørflygt	—	—	Funktion 7	Funktion f7	Funktion f7
Frontsignal, førerstand 1 slukket*	—	—	Funktion 8	Funktion f8	Funktion f8
Lyd: Kompressor	—	—	—	Funktion f9	Funktion f9
Lyd: Blæser	—	—	—	Funktion f10	Funktion f10
Lyd: Signalhorn 2	—	—	—	Funktion f11	Funktion f11
Rangergear	—	—	—	Funktion f12	Funktion f12
Rangerlys dobbelt A	—	—	 + f1 + f8	f0 + f6 + f8	f0 + f6 + f8

* kun i forbindelse med Frontsignal

CV (Parameter) • CV (Parameter) • CV (Paramètre) • CV (Parameter) • CV (Parámetro) • CV (Parametro) • CV (Parameter) • CV (Parameter)	CV-Nr.	Wert • Value • Valeur • Waarde • Valor • Valore • Värde • Værdi
Adresse • Address • Adresse • Adres • Código • Indirizzo • Adress • Adresse	01	01 - (80)* 255
Anfahrverzögerung • Acceleration delay • Temporisation accélération • Optrekvertraging • Regulación arranque • Ritardo di avviamento • Igångsättningsreglering • Kørselsforsinkelse	03	01 - (63)* 255
Bremsverzögerung • Braking delay • Temporisation de freinage • Afremvertraging • Frenado lento • Ritardo di frenatura • Bromsfördröjning • Bremseforsinkelse	04	01 - (63)* 255
Höchstgeschwindigkeit • Maximum speed • Vitesse maximale • Maximumsneilheid • Velocidad máxima • Velocità massima • Toppfart • Maksimalhastighed	05	01 - (63)* 255
Rückstellen auf Serienwerte • Reset to series value • Remettre aux valeurs de série • Terugzetten naar serie-instellingen • Restablecer los valores de serie • Ripristinare sui valori di serie • Återställa till standardvärden • Tibagestil til serieværdien	08	08
Lautstärke • Volume • Volume haut-parleur • Volume • Volumen del sonido • Intensità del suono • Ljudstyrka • Lydstyrke	63	01 - (63)* 255

* () Control Unit 6021 / Mobile Station 60651/60652

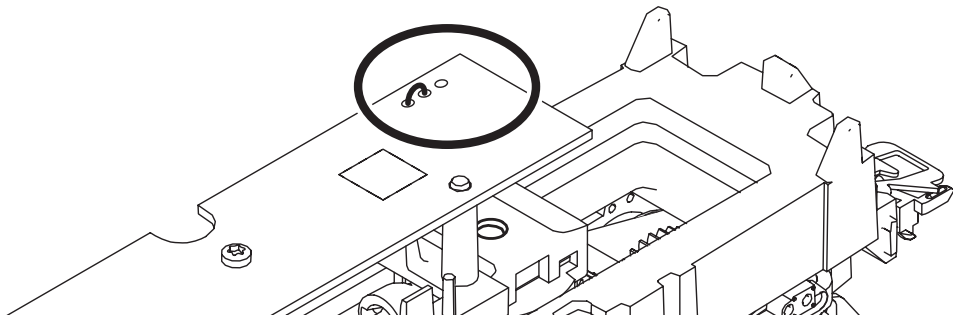
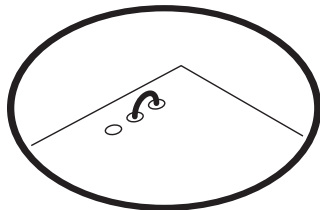
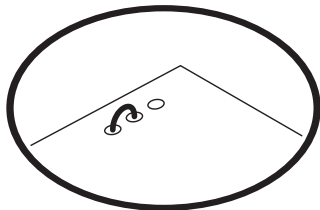

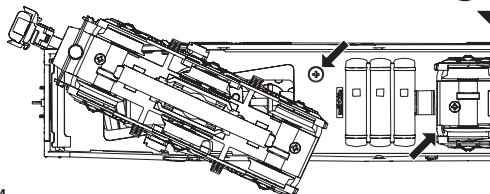
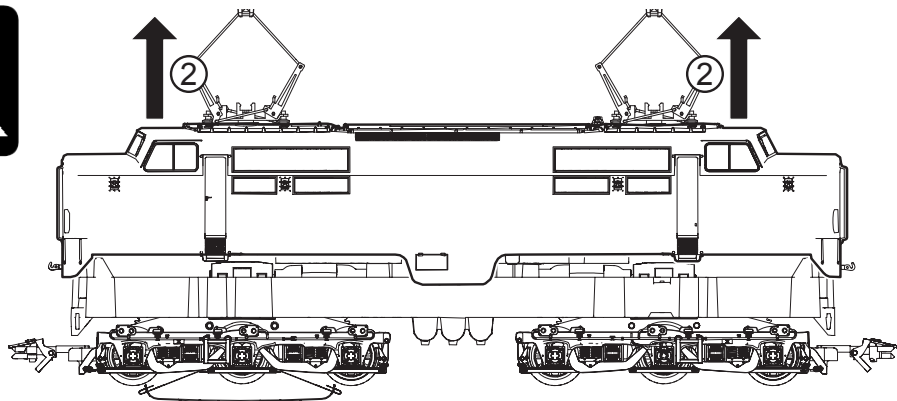

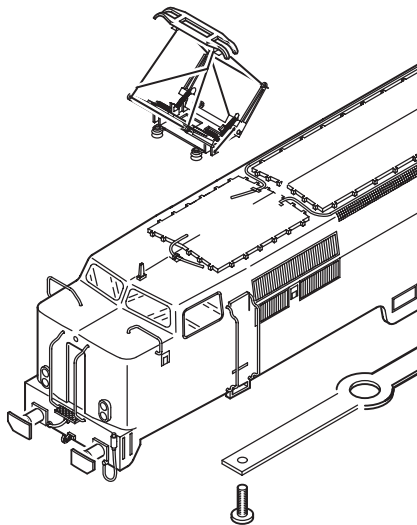
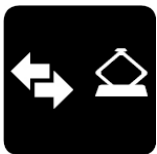

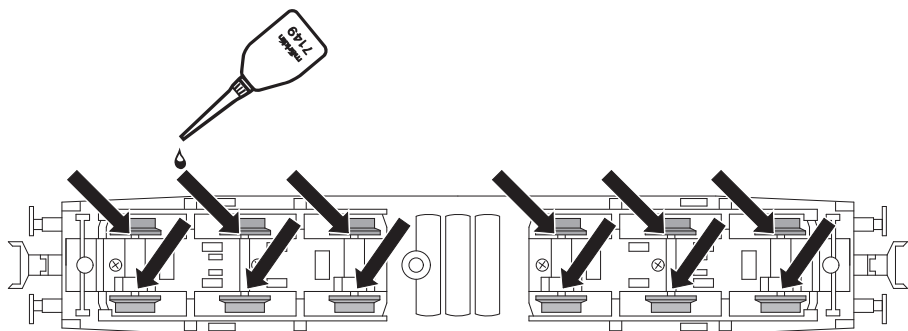



Trix 66626

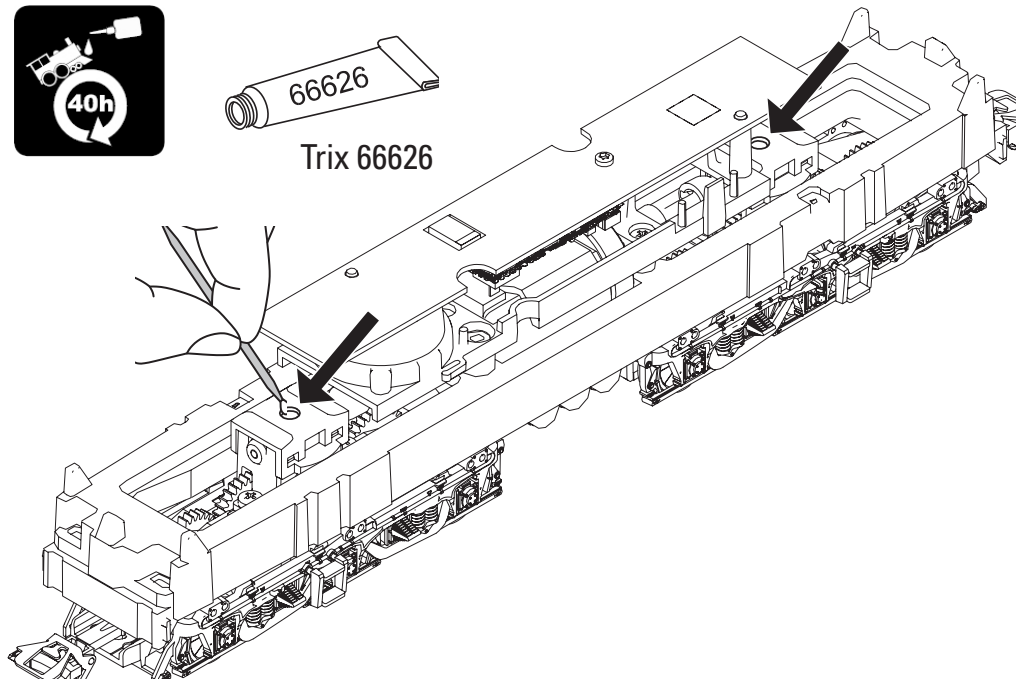

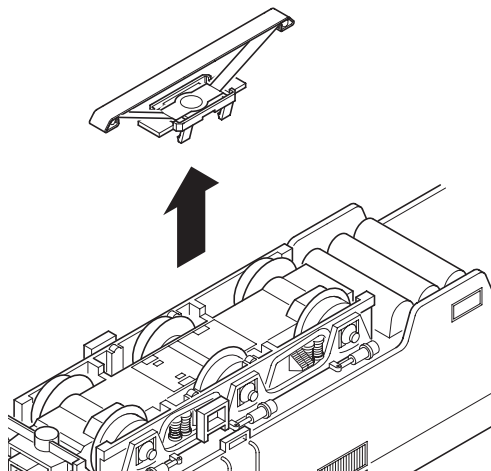

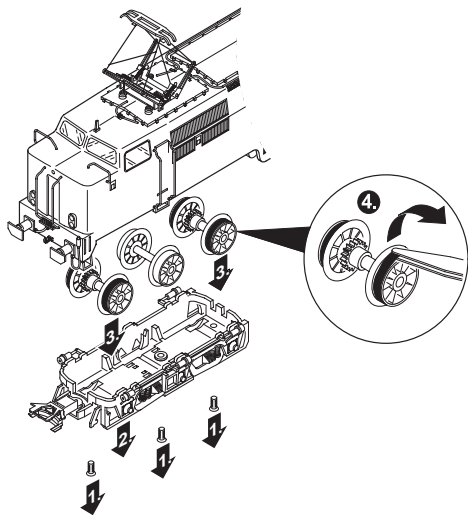
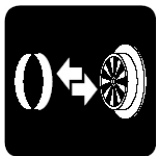

NEM 362

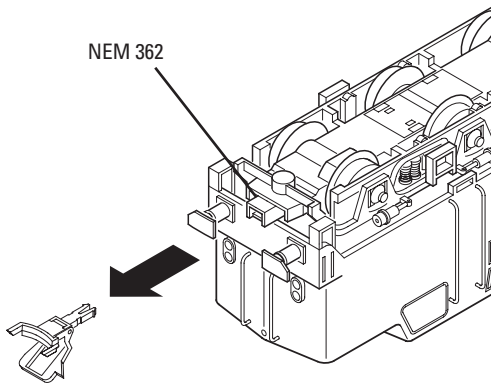

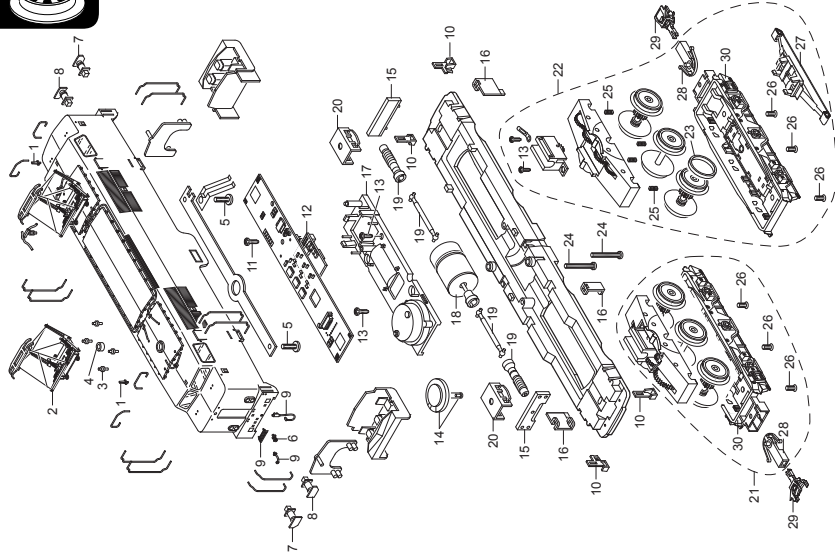

Details der Darstellung können von dem Modell abweichen.

1 Antenne	E243 534
2 Stromabnehmer	E662 450
3 Isolator	E662 500
4 Abstandshülse	E277 970
5 Schraube	E750 200
6 Haken	E282 390
7 Puffer rechts	E229 949
8 Puffer links	E229 951
9 Schläuche, Tritt	E245 161
10 Trittstufen	E182 630
11 Schraube	E786 341
12 Decoder	243 551
13 Schraube	E786 750
14 Lautsprecher	E182 576
15 Beleuchtungseinheit	E245 683
16 Haltestücke	E192 539
17 Halteplatte	E104 431
18 Motor	E246 923
19 Wellen	E245 162
20 Halteklammer	E230 561
21 Treibgestell	E245 163
22 Treibgestell	E245 164
23 Haftreifen	7 154
24 Schraube	E756 290
25 Druckfeder	E765 690
26 Schraube	E786 790
27 Schleifer	E138 079
28 Kupplungsdeichsel	E216 694
29 Kurzkupplung	E701 630
30 Drehgestellrahmen	E245 165
Bremsleitung	E12 514 900

Hinweis: Einige Teile werden nur ohne oder mit anderer Farbgebung angeboten.

Teile, die hier nicht aufgeführt sind, können nur im Rahmen einer Reparatur im Märklin-Reparatur-Service repariert werden.

Due to different legal requirements regarding electro-magnetic compatibility, this item may be used in the USA only after separate certification for FCC compliance and an adjustment if necessary.

Use in the USA without this certification is not permitted and absolves us of any liability. If you should want such certification to be done, please contact us – also due to the additional costs incurred for this.



Gebr. Märklin & Cie. GmbH
Stuttgarter Straße 55 - 57
73033 Göppingen
Germany
www.maerklin.com

www.maerklin.com/en/imprint.html

244441/1014/Ha2Ef
Änderungen vorbehalten
© Gebr. Märklin & Cie. GmbH