



Modell der E 10.12, Rheinpfail  
**37014**

<b>Inhaltsverzeichnis</b>	<b>Seite</b>	<b>Sommaire</b>	<b>Page</b>
Informationen zum Vorbild	4	Informations concernant la locomotive réelle	5
Sicherheitshinweise	6	Remarques importantes sur la sécurité	10
Wichtige Hinweise	6	Information importante	10
Funktionen	6	Fonctionnement	10
Schaltbare Funktionen	7	Fonctions commutables	11
Parameter / Register	22	Paramètre / Registre	22
Betriebshinweise	23	Remarques sur l'exploitation	23
Wartung und Instandhaltung	24	Entretien et maintien	24
Ersatzteile	30	Pièces de rechange	30

<b>Table of Contents</b>	<b>Page</b>	<b>Inhoudsopgave</b>	<b>Pagina</b>
Information about the prototype	4	Informatie van het voorbeeld	5
Safety Notes	8	Veiligheidsvoorschriften	12
Important Notes	8	Belangrijke aanwijzing	12
Functions	8	Functies	12
Controllable Functions	9	Schakelbare functies	13
Parameter / Register	22	Parameter / Register	22
Information about operation	23	Opmerkingen over de werking	23
Service and maintenance	24	Onderhoud en handhaving	24
Spare Parts	30	Onderdelen	30

<b>Indice de contenido</b>	<b>Página</b>	<b>Innehållsförteckning</b>	<b>Sida</b>
Aviso de seguridad	14	Säkerhetsanvisningar	18
Notas importantes	14	Viktig information	18
Funciones	14	Funktioner	18
Funciones posibles	15	Kopplingsbara funktioner	19
Parámetro / Registro	22	Parameter / Register	22
Instrucciones de uso	23	Driftanvisningar	23
El mantenimiento	24	Underhåll och reparation	24
Recambios	30	Reservdelar	30

<b>Indice del contenido</b>	<b>Página</b>	<b>Indholdsfortegnelse:</b>	<b>Side</b>
Avvertenze per la sicurezza	16	Vink om sikkerhed	20
Avvertenze importanti	16	Vigtige bemærkninger	20
Funzioni	16	Funktioner	20
Funzioni commutabili	17	Styrbare funktioner	21
Parametro / Registro	22	Parameter / Register	22
Avvertenze per il funzionamento	23		23
Manutenzione ed assistere	24	Service og reparation	24
Pezzi di ricambio	30	Reservedele	30

## Information zum Vorbild

Nach der Gründung der Deutschen Bundesbahn war es das wichtigste Ziel des jungen Unternehmens, den veralteten Fuhrpark zu erneuern.

Für den Schnellzugdienst einigte man sich nach intensiver Erprobung mit 5 Vorserienlokomotiven der Baureihe E 10.0 auf die Baureihe E 10.1 bis E 10.3, die ab 1956 in mehreren Serien 379 mal von den Firmen Krauss-Maffei, Krupp, Henschel-Werke (mechanischer Teil) sowie SSW (Siemens-Schuckert-Werke), AEG und BBC (elektrischer Teil) an die Bundesbahn ausgeliefert werden sollte. Ein geschweißter Kastenaufbau mit Einfach-, später Doppellampen und Lüftergittern ruhte auf geschweißten Drehgestellen in Kastenbauweise mit Drehzapfen. Ab der E 10 288 wurde der elegantere „Bügelalten“-Lokkasten der E 10.12 auch bei den normalen E 10 verwendet, die dann als BR E 10.3 eingereiht wurden. Die E 10 erhielt auch den, bei den Vorserienlokomotiven bewährten, Gummiringfeder-Antrieb und vier 14-polige Fahrmotoren des Typs WB 372, die bei späteren Baureihen wie z.B. der BR 111 und BR 151 Verwendung fanden. Die Transformatoren, bei denen das erste Mal in Deutschland serienmäßig eine Hochspannungssteuerung verwendet wurde, sind mit Öl gekühlt, an denen ein Schaltwerk mit 28 Fahrstufen angeschlossen ist. Die 85 t schwere, 16.490 mm lange und maximal 150 km/h schnelle Lok hat eine Dauerleistung von 3.700 kW.

In den ersten Jahren war die E 10 das Rückgrat des Schnellzugverkehrs, bis schnellere, stärkere Loks wie die BR E 03/103 und dann die BR 101 ihr den Rang abliefen. Heute sind die restlichen verbliebenen Maschinen mehrheitlich im Regionaldienst unterwegs.

## Information about the Prototype

After the founding of the German Federal Railroad, the most important goal for the new firm was to renew the worn out motive power roster.

After intensive testing with 5 pre-production class E 10.0 locomotives, the class E 10.1 to E 10.3 was selected for express train service. A total of 379 units were to be delivered to the German Federal Railroad and were built starting in 1956 in several production runs by the firms Krauss-Maffei, Krupp, Henschel-Werke (mechanical part) as well as SSW (Siemens-Schuckert-Werke), AEG, and BBC (electrical part). A welded box-style body with simple, later double lamps, and vent grills rested on welded trucks of box-style construction with truck center pins. Starting with road number E 10 288, the elegant “pant’s crease” locomotive body of the E 10.12 was also used with the standard E 10, which was then designated as the class E 10.3. The E 10 was also equipped with the rubber ring spring propulsion proven on the pre-production locomotives and four type WB 372 14-pole traction motors, which were used on later locomotive classes such as the class 111 and class 151. The transformers were the first regular production units in Germany to have high voltage control and were cooled with oil. A relay system with 28 speed steps was connected to the transformers. These locomotives weighed 85 metric tons, measured 16,490 mm / 54 feet 1-3/16” in length, had a maximum speed of 150 km/h / 93 mph, and had a continuous performance rating of 3,700 kilowatts / 4,961.78 horsepower.

In the first years the E 10 was the backbone of the express train service until faster, more powerful locomotives such as the class E 03/103 and then the class 101 supplanted them. Currently, the majority of the remaining units are used in regional service.

## Informations concernant la locomotive réelle

Après la création de la Deutsche Bundesbahn, la principale ambition de la jeune entreprise était de renouveler le parc de véhicules devenu obsolète.

Pour le service de trains rapides, on se décida – après des essais intensifs avec 5 locomotives de pré-série (série E 10.0) pour la série E 10.1 à E 10.3, dont 379 unités devaient être livrées à partir de 1956 à la Bundesbahn en plusieurs lots par les firmes Krauss-Maffei, Krupp, Henschel-Werke (pour la partie mécanique) ainsi que SSW (Siemens-Schuckert-Werke), AEG et BBC (pour la partie électrique). Une caisse soudée avec un, puis deux feux et des grilles d'aération reposait sur des bogies soudés en forme de caisson avec un pivot. A partir de la E 10 288, l'élégante caisse à «pli» de la E 10.12 fut également utilisée pour les E 10 normales, immatriculées alors dans la série BR E 10.3. La E 10 fut également dotée de la transmission à ressorts et courroies en caoutchouc – qui avait fait ses preuves sur les locomotives de pré-série – ainsi que de quatre moteurs à 14 pôles du type WB 372, également utilisés sur des séries ultérieures telles que la BR 111 et la BR 151. Les transformateurs, sur lesquels fut utilisée pour la première fois de série en Allemagne une commande à haute tension, sont dotés de radiateurs à huile, et un dispositif de commutation avec 28 crans de marche y est relié. Cette locomotive pesant 85 t, mesurant 16 490 mm de long et pouvant atteindre une vitesse de 150 km/h, affiche une puissance continue de 3700 kW.

Au cours des premières années, la E 10 représentait l'épine dorsale du trafic de trains rapides jusqu'à ce que des locomotives plus rapides et plus puissantes, telles que la BR E 03/103, puis la BR 101 lui volent la place. Aujourd'hui, les machines restantes sont pour la plupart affectées au trafic régional.

## Informatie van het voorbeeld

Na de stichting van de Deutsche Bundesbahn was het belangrijkste doel van de jonge onderneming het verouderde tractiepark te vernieuwen.

Voor de sneltreindienst accordeerde men na intensieve proeven tot 5 voorserielocomotieven van de serie E 10.0 tot de serie E 10.1 tot E 10.3, die vanaf 1956 in meerdere series 379 maal door de firma's Krauss-Maffei, Krupp, Henschel-Werke (mechanische deel) en SSW (Siemens-Schuckert-Werke), AEG en BBC (elektrische deel) aan de Bundesbahn geleverd moesten worden. Een gelaste bakopbouw met enkelvoudige, later dubbele lampen en ventilatorroosters rustte op gelaste draaistellen in een bakconstructie met draaitappen. Vanaf de E 10 288 werd de elegantere "Bügefalten"-locbak van de E 10.12 ook bij de normale E 10 gebruikt, die vervolgens als BR E 10.3 ingedeeld werd. De E 10 kreeg ook de bij de voorserielocomotieven beproefde Gummiringfeder-aandrijving en vier 14-polige tractiemotoren van het type WB 372, die bij latere series zoals de BR 111 en BR 151 toepassing vonden. De transformatoren, waarbij voor het eerst in Duitsland standaard een hoogspanningsregeling gebruikt werd, zijn met olie gekoeld, waaraan een schakelmechanisme met 28 rijtrappen aangesloten is. De 85 t zware, 16.490 mm lange en maximaal 150 km/h snelle loc heeft een continu vermogen van 3.700 kW.

In het eerste jaar was de E 10 de ruggengraat van het sneltreinverkeer tot snellere, sterkere locs, zoals de BR E 03/103 en daarna de BR 101 hen de loef afstaken. Tegenwoordig zijn de resterende machines in meerderheid in de regionale dienst onderweg.

## Sicherheitshinweise









- Die Lok darf nur mit einem dafür bestimmten Betriebssystem (Märklin Wechselstrom, Märklin Delta, Märklin Digital oder Märklin Systems) eingesetzt werden.
- Nur Schaltnetzteile/Transformatoren verwenden, die Ihrer örtlichen Netzspannung entsprechen.
- Die Lok darf nur aus einer Leistungsquelle versorgt werden.
- Beachten Sie unbedingt die Sicherheitshinweise in der Bedienungsanleitung zu Ihrem Betriebssystem.
- Für den konventionellen Betrieb der Lok muss das Anschlussgleis entstört werden. Dazu ist das Entstörset 74046 zu verwenden. Für Digitalbetrieb ist das Entstörset nicht geeignet.
- **ACHTUNG!** Funktionsbedingte scharfe Kanten und Spitzen.
- Setzen Sie das Modell keiner direkten Sonneneinstrahlung, starken Temperaturschwankungen oder hoher Luftfeuchtigkeit aus.
- Wartung, Instandhaltung und Reparaturen dürfen nur durch Erwachsene durchgeführt werden.

## Wichtige Hinweise

- Die Bedienungsanleitung und die Verpackung sind Bestandteile des Produktes und müssen deshalb aufbewahrt sowie bei Weitergabe des Produktes mitgegeben werden.
- Für Reparaturen oder Ersatzteile wenden Sie sich bitte an Ihren Märklin-Fachhändler.
- Gewährleistung und Garantie gemäß der beiliegenden Garantieurkunde.
- <http://www.maerklin.com/en/imprint.html>

## Funktionen

- Erkennung der Betriebsart: automatisch.
- Einstellbare Adressen:  
**1-80** (Control Unit 6021/Mobile Station 60651/652)  
**1-255** (Central Station 6021x/Mobile Station 60653)
- Adresse ab Werk: **10**
- Mfx-Technologie für Mobile Station / Central Station.  
Name ab Werk: **E10 1309 DB**
- Veränderbare Anfahrverzögerung (ABV).
- Veränderbare Bremsverzögerung (ABV).
- Veränderbare Höchstgeschwindigkeit.
- Einstellen der Lokparameter (Adresse, Anfahr-/Bremsverzögerung, Höchstgeschwindigkeit): über Control Unit, Mobile Station oder Central Station.
- Fahrtrichtungsabhängige Stirnbeleuchtung.
- Im Analogbetrieb stehen nur die Fahr- und Lichtwechselfunktionen zur Verfügung.

Schaltbare Funktionen					 Digital / Systems
Spitzensignal	function/off			Funktion f0	Funktion f0
Geräusch: Bahnofsansage	f1	Funktion 1	Funktion 5	Funktion f1	Funktion f1
Geräusch: Betriebsgeräusch	f2	Funktion 2	Funktion 3	Funktion f2	Funktion f2
Geräusch: Lokpfeife	f3	Funktion 3	Funktion 4	Funktion f3	Funktion f3
ABV aus	f4	Funktion 4	Funktion 2	Funktion f4	Funktion f4
Geräusch: Bremsenquietschen aus	—	—	Funktion 6	Funktion f5	Funktion f5
Stirnbeleuchtung Führerstand 2 aus	—	—	Funktion 1	Funktion f6	Funktion f6
Geräusch: Schaffnerpiff	—	—	Funktion 7	Funktion f7	Funktion f7
Stirnbeleuchtung Führerstand 1 aus	—	—	Funktion 8	Funktion f8	Funktion f8
Geräusch: Kompressor	—	—	—	Funktion f9	Funktion f9
Geräusch: Druckluft ablassen	—	—	—	Funktion f10	Funktion f10
Rangierlicht Doppel A	—	—	 + 1 + 8	f0 + f6 + f8	f0 + f6 + f8

## Safety Notes

- This locomotive is to be used only with an operating system designed for it (Märklin AC, Märklin Delta, Märklin Digital or Märklin Systems).
- Use only switched mode power supply units and transformers that are designed for your local power system.
- This locomotive must never be supplied with power from more than one transformer.
- Pay close attention to the safety notes in the instructions for your operating system.
- The feeder track must be equipped to prevent interference with radio and television reception, when the locomotive is to be run in conventional operation. The 74046 interference suppression set is to be used for this purpose.
- **WARNING!** Sharp edges and points required for operation.
- Do not expose the model to direct sunlight, extreme changes in temperature, or high humidity.
- Maintenance, servicing, and repairs may only be done by adults.









## Important Notes

- The operating instructions and the packaging are a component part of the product and must therefore be kept as well as transferred along with the product to others.
- Please see your authorized Märklin dealer for repairs or spare parts.
- The warranty card included with this product specifies the warranty conditions.
- <http://www.maerklin.com/en/imprint.html>

## Functions

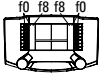
- Recognition of the mode of operation: automatic.
- Addresses that can be set:  
**1-80** (Control Unit 6021/Mobile Station 60651/652)  
**1-255** (Central Station 6021x/Mobile Station 60653)
- Address set at the factory: **10**
- Mfx technology for the Mobile Station / Central Station.  
Name set at the factory: **E10 1309 DB**
- Adjustable Acceleration delay (ABV).
- Adjustable Braking delay (ABV).
- Adjustable maximum speed.
- Setting the locomotive parameters (address, acceleration/braking delay, maximum speed): with the Control Unit, Mobile Station, Central Station.
- Headlights, changing over with the direction of travel.
- Only the train control functions and headlight changeover feature are available in analog operation.



Controllable Functions					 Digital / Systems
Headlights/marker lights	function/off			Function f0	Function f0
Sound effect: Station announcements	f1	Function 1	Function 5	Function f1	Function f1
Sound effect: Operating sounds	f2	Function 2	Function 3	Function f2	Function f2
Sound effects: Locomotive whistle	f3	Function 3	Function 4	Function f3	Function f3
ABV off	f4	Function 4	Function 2	Function f4	Function f4
Sound effect: Squealing brakes off	—	—	Function 6	Function f5	Function f5
Headlights at engineer's cab 2 off	—	—	Function 1	Function f6	Function f6
Sound effect: Conductor whistle	—	—	Function 7	Function f7	Function f7
Headlights at engineer's cab 1 off	—	—	Function 8	Function f8	Function f8
Sound effect: compressor	—	—	—	Function f9	Function f9
Sound effect: Letting off air	—	—	—	Function f10	Function f10
Double A switching light	—	—	 + 1 + 8	f0 + f6 + f8	f0 + f6 + f8

### Remarques importantes sur la sécurité

- La locomotive ne peut être mise en service qu'avec un système d'exploitation adéquat (Märklin AC, Märklin Delta, Märklin Digital ou Märklin Systems).
- Utiliser uniquement des convertisseurs et transformateurs correspondant à la tension du secteur local.
- La locomotive ne peut être alimentée en courant que par une seule source de courant.
- Veuillez impérativement respecter les remarques sur la sécurité décrites dans le mode d'emploi de votre système d'exploitation.
- Pour l'exploitation de la locomotive en mode conventionnel, la voie de raccordement doit être déparasitée. A cet effet, utiliser le set de déparasitage réf. 74046. Le set de déparasitage ne convient pas pour l'exploitation en mode numérique.
- **ATTENTION!** Pointes et bords coupants lors du fonctionnement du produit.
- Ne pas exposer le modèle à un ensoleillement direct, à de fortes variations de température ou à un taux d'humidité important.
- Seules des personnes adultes sont habilitées pour l'entretien, la maintenance et les réparations.









### Information importante

- La notice d'utilisation et l'emballage font partie intégrante du produit ; ils doivent donc être conservés et, le cas échéant, transmis avec le produit.
- Pour toute réparation ou remplacement de pièces, adressez-vous à votre détaillant-spécialiste Märklin.
- Garantie légale et garantie contractuelle conformément au certificat de garantie ci-joint.

- <http://www.maerklin.com/en/imprint.html>

### Fonctionnement

- Détection du mode d'exploitation : automatique.
- Adresses disponibles :  
**1-80** (Control Unit 6021/Mobile Station 60651/652)  
**1-255** (Central Station 6021x/Mobile Station 60653)
- Adresse encodée en usine : **10**
- Technologie mfx pour Mobile Station / Central Station.  
Nom encodée en usine : **E10 1309 DB**
- Temporisation d'accélération réglable (ABV).
- Temporisation de freinage réglable (ABV).
- Vitesse maximale réglable.
- Réglage des paramètres de la loco (adresse, temporisation accélér.-freinage, vitesse maximale) : via Control Unit, Mobile Station ou Central Station.
- Feux de signalisation avec inversion selon sens de marche.
- En mode d'exploitation analogique, seules les fonctions relatives à la conduite et à l'inversion des feux sont disponibles.

Fonctions commutables					 Digital / Systems
Fanal	function/off			Fonction f0	Fonction f0
Bruitage : Annonce en gare	f1	Fonction 1	Fonction 5	Fonction f1	Fonction f1
Bruitage : Bruit d'exploitation	f2	Fonction 2	Fonction 3	Fonction f2	Fonction f2
Bruitage : Sifflet locomotive	f3	Fonction 3	Fonction 4	Fonction f3	Fonction f3
ABV désactivé	f4	Fonction 4	Fonction 2	Fonction f4	Fonction f4
Bruitage : Grincement de freins désactivé	—	—	Fonction 6	Fonction f5	Fonction f5
Fanal de la cabine de conduite 2 éteint	—	—	Fonction 1	Fonction f6	Fonction f6
Bruitage : Sifflet Contrôleur	—	—	Fonction 7	Fonction f7	Fonction f7
Fanal de la cabine de conduite 1 éteint	—	—	Fonction 8	Fonction f8	Fonction f8
Bruitage : Compresseur	—	—	—	Fonction f9	Fonction f9
Bruitage : Échappement de l'air comprimé	—	—	—	Fonction f10	Fonction f10
Feu de manœuvre double A	—	—	 + 1 + 8	f0 + f6 + f8	f0 + f6 + f8

## Veiligheidsvoorschriften









- De loc mag alleen met een daarvoor bestemd bedrijfssysteem (Märklin AC, Märklin Delta, Märklin digitaal of Märklin Systems) gebruikt worden.
- Alleen net-adapters en transformatoren gebruiken waarvan de aangegeven netspanning overeenkomt met de netspanning ter plaatse.
- De loc mag niet vanuit meer dan een stroomvoorziening gelijktijdig gevoed worden.
- Lees ook aandachtig de veiligheidsvoorschriften in de gebruiksaanwijzing van uw bedrijfssysteem.
- Voor het conventionele bedrijf met de loc dient de aansluitrail te worden ontstoort. Hiervoor dient men de ontstoor-set 74046 te gebruiken. Voor het digitale bedrijf is deze ontstoor-set niet geschikt.
- **OPGEPAST!** Functionele scherpe kanten en punten.
- Stel het model niet bloot aan in directe zonnestraling, sterke temperatuurwisselingen of hoge luchtvochtigheid.
- Onderhoud, herstellingen en reparaties mogen alleen door volwassenen uitgevoerd worden.

## Belangrijke aanwijzing

- De gebruiksaanwijzing en de verpakking zijn een bestanddeel van het product en dienen derhalve bewaard en meegeleverd te worden bij het doorgeven van het product.
- Voor reparatie of onderdelen kunt u zich tot uw Märklin handelaar wenden.
- Vrijwaring en garantie overeenkomstig het bijgevoegde garantiebewijs.
- <http://www.maerklin.com/en/imprint.html>

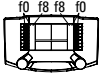
## Funcities

- Herkenning van het bedrijfssysteem: automatisch.
- Instelbare adressen:  
**1-80** (Control Unit 6021/Mobile Station 60651/652)  
**1-255** (Central Station 6021x/Mobile Station 60653)
- Vanaf de fabriek ingesteld: **10**
- Mfx-technologie voor het Mobile Station/Central Station. Naam af de fabriek: **E10 1309 DB**
- Instelbare optrekvertraging (ABV).
- Instelbare afremvertraging (ABV).
- Instelbare maximumsnelheid.
- Instellen van de locomotiefparameters (adres, optrek-/afremvertraging, maximumsnelheid): d.m.v. Control Unit, Mobile Station of Central Station.
- Rijrichtingafhankelijke frontseinen.
- In analoogbedrijf zijn alleen de rij- en lichtwissel-functies beschikbaar.

Schakelbare functies					 Digital / Systems
Frontverlichting	function/off			Functie f0	Functie f0
Geluid: stationsomroep	f1	Functie 1	Functie 5	Functie f1	Functie f1
Geluid: bedrijfsgeluiden	f2	Functie 2	Functie 3	Functie f2	Functie f2
Geluid: locfluit	f3	Functie 3	Functie 4	Functie f3	Functie f3
ABV uit	f4	Functie 4	Functie 2	Functie f4	Functie f4
Geluid: piepende remmen uit	—	—	Functie 6	Functie f5	Functie f5
Frontverlichting Cabine 2 uit	—	—	Functie 1	Functie f6	Functie f6
Geluid: conducteurfluit	—	—	Functie 7	Functie f7	Functie f7
Frontverlichting Cabine 1 uit	—	—	Functie 8	Functie f8	Functie f8
Geluid: compressor	—	—	—	Functie f9	Functie f9
Geluid: perslucht afblazen	—	—	—	Functie f10	Functie f10
Rangerlicht dubbel A	—	—	 + 1 + 8	f0 + f6 + f8	f0 + f6 + f8

## Aviso de seguridad

- La locomotora solamente debe funcionar en un sistema de corriente propio (Märklin AC – Märklin Delta – Märklin Digital o Märklin Systems).
- Emplear únicamente fuentes de alimentación conmutadas y transformadores que sean de la tensión de red local.
- La alimentación de la locomotora deberá realizarse desde una sola fuente de suministro.
- Observe bajo todos los conceptos, las medidas de seguridad indicadas en las instrucciones de su sistema de funcionamiento.
- Para el funcionamiento convencional de la locomotora deben suprimirse las interferencias en la vía de conexión de la alimentación. Para ello debe emplearse el set supresor de interferencias 74046. El set supresor de interferencias no es adecuado para el funcionamiento en modo digital.
- **¡ATENCIÓN!** Esquinas y puntas afiladas condicionadas a la función.
- No exponer el modelo en miniatura a la radiación solar directa, a oscilaciones fuertes de temperatura o a una humedad del aire elevada.
- El mantenimiento, la conservación y las reparaciones deben ser realizadas siempre por adultos.

## Notas importantes









- Las instrucciones de empleo y el embalaje forman parte íntegra del producto y, por este motivo, deben guardarse y entregarse junto con el producto en el caso de venderlo o transmitirlo a otro.
- Para reparaciones o recambios contacte con su proveedor

de Märklin especializado.

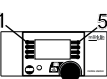
- Responsabilidad y garantía conforme al documento de garantía que se adjunta.
- <http://www.maerklin.com/en/imprint.html>

## Funciones

- Reconocimiento del sistema: automático.
- Códigos disponibles:
  - 1-80** (Control Unit 6021/Mobile Station 60651/652)
  - 1-255** (Central Station 6021x/Mobile Station 60653)
- Código de fábrica: **10**
- Tecnología mfx para la Mobile Station/Central Station.  
Nombre de fábrica: **E10 1309 DB**
- Arranque lento variable (ABV).
- Frenado lento variable (ABV).
- Velocidad máxima variable.
- Fijar parámetros de la locomotora (código, arranque y frenado, velocidad máxima): por el Control Unit, Mobile Station o Central Station.
- Faros frontales dependientes del sentido de marcha.
- En funcionamiento en modo analógico están disponibles únicamente las funciones de tracción y de alternancia de luces.

Funciones posibles					 Digital / Systems
Faros frontales	function/off			Función f0	Función f0
Ruido: Locución hablada en estaciones	f1	Función 1	Función 5	Función f1	Función f1
Ruido: ruido de explotación	f2	Función 2	Función 3	Función f2	Función f2
Ruido del silbido de la locomotora	f3	Función 3	Función 4	Función f3	Función f3
ABV, apagado	f4	Función 4	Función 2	Función f4	Función f4
Ruido: Desconectar chirrido de los frenos	—	—	Función 6	Función f5	Función f5
Faros frontales a la cabina 2 de enganche	—	—	Función 1	Función f6	Función f6
Ruido: Silbato de Revisor	—	—	Función 7	Función f7	Función f7
Faros frontales a la cabina 1 de enganche	—	—	Función 8	Función f8	Función f8
Ruido: Compresor	—	—	—	Función f9	Función f9
Ruido: Purgar aire comprimido	—	—	—	Función f10	Función f10
Luces de maniobra doble A	—	—	 + 1 + 8	f0 + f6 + f8	f0 + f6 + f8

### Avvertenze per la sicurezza

- Tale locomotiva deve essere impiegata soltanto con un sistema di funzionamento adeguato per questa (Märklin AC, Märklin Delta, Märklin Digital oppure Märklin Systems).
- Impiegare soltanto alimentatori "switching" e trasformatori che corrispondono alla Vostra tensione di rete locale.
- La locomotiva non deve venire alimentata nello stesso tempo con più di una sorgente di potenza.
- Vogliate prestare assolutamente attenzione alle avvertenze di sicurezza nelle istruzioni di impiego per il Vostro sistema di funzionamento.
- Per il funzionamento tradizionale della locomotiva il binario di alimentazione deve essere protetto dai disturbi. A tale scopo si deve impiegare il corredo antidisturbi 74046. Tale corredo antidisturbi non è adatto per il funzionamento Digital.
- **AVVERTENZA!** Per motivi funzionali i bordi e le punte sono spigolosi.
- Non esponete tale modello ad alcun irraggiamento solare diretto, a forti escursioni di temperatura oppure a elevata umidità dell'aria.
- Manutenzione, tenuta in efficienza e riparazioni possono venire eseguite soltanto da parte di adulti.

### Avvertenze importanti









- Le istruzioni di impiego e l'imballaggio costituiscono un componente sostanziale del prodotto e devono pertanto venire conservati nonché consegnati insieme in caso di ulteriore cessione del prodotto.
- Per le riparazioni o le parti di ricambio, contrattare il rivenditore Märklin.

- Prestazioni di garanzia e garanzia in conformità all'accluso certificato di garanzia.
- <http://www.maerklin.com/en/imprint.html>

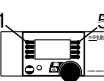
### Funzioni

- Riconoscimento del tipo di funzionamento: automatico.
- Indirizzi impostabili:  
**1-80** (Control Unit 6021/Mobile Station 60651/652)  
**1-255** (Central Station 6021x/Mobile Station 60653)
- Indirizzo di fabbrica: **10**
- Tecnologia Mfx per Mobile Station / Central Station.  
Nome di fabbrica: **E10 1309 DB**
- Ritardo di avviamento modificabile (ABV).
- Ritardo di frenatura modificabile (ABV).
- Velocità massima modificabile.
- Regolazione dei parametri della locomotiva (indirizzo, ritardo di avviamento/frenatura, velocità massima): tramite Control Unit, Mobile Station oppure Central Station.
- Illuminazione di testa dipendente dalla direzione di marcia.
- Nel funzionamento analogico si hanno a disposizione solamente le funzioni di marcia e di commutazione dei fanali.



Funzioni commutabili					 Digital / Systems
Illuminazione di testa	function/off			Funzione f0	Funzione f0
Rumore: annuncio di stazione	f1	Funzione 1	Funzione 5	Funzione f1	Funzione f1
Rumore: rumori di esercizio	f2	Funzione 2	Funzione 3	Funzione f2	Funzione f2
Rumore: fischio da locomotiva	f3	Funzione 3	Funzione 4	Funzione f3	Funzione f3
ABV, spento	f4	Funzione 4	Funzione 2	Funzione f4	Funzione f4
Rumore: stridore dei freni escluso	—	—	Funzione 6	Funzione f5	Funzione f5
Illuminazione di testa della cabina 2 spento	—	—	Funzione 1	Funzione f6	Funzione f6
Rumore: fischio di capotreno	—	—	Funzione 7	Funzione f7	Funzione f7
Illuminazione di testa della cabina 1 spento	—	—	Funzione 8	Funzione f8	Funzione f8
Rumore: compressore	—	—	—	Funzione f9	Funzione f9
Rumore: scarico dell'aria compressa	—	—	—	Funzione f10	Funzione f10
Fanale di manovra a doppia A	—	—	 + 1 + 8	f0 + f6 + f8	f0 + f6 + f8

## Säkerhetsanvisningar









- Loket får endast köras med ett därtill avsett driftsystem (Märklin AC, Märklin Delta, Märklin Digital eller Märklin Systems).
- Använd endast nätadapterar och transformatorer anpassade för det lokala elnätet.
- Loket får inte samtidigt försörjas av mer än en kraftkälla.
- Beakta alltid säkerhetsanvisningarna i bruksanvisningen som hör till respektive driftsystemet.
- När motorvagnens lokdel ska köras med konventionell/ analog drift måste anlutningsskenan vara avstörd. Till detta använder man anslutningsgarnityr 74046 med avstörning och överbelastningsskydd. Avstörningsskyddet får inte användas vid digital körning.
- **WARNING!** Funktionsbetingade vassa kanter och spetsar.
- Modellen får inte utsättas för direkt solljus, häftiga temperaturväxlingar eller hög luftfuktighet.
- Underhåll, service och reparationer får endast utföras av vuxna personer.

## Viktig information

- Bruksanvisningen och förpackningen är en del av produkten och måste därför sparas och alltid medfölja produkten.
- Kontakta din Märklinfackhandlare för reparationer och reservdelar.
- Garantivillkor framgår av bifogade garantibevis.
- <http://www.maerklin.com/en/imprint.html>

## Funktioner

- Driftsättet igenkänns automatiskt.
- Inställbara adresser:  
**1-80** (Control Unit 6021/Mobile Station 60651/652)  
**1-255** (Central Station 6021x/Mobile Station 60653)
- Adress från tillverkaren: **10**
- Mfx-teknologi för Mobile Station / Central Station. Namn från tillverkaren: **E10 1309 DB**
- Accelerationsfördröjning kan ändras (ABV).
- Bromsfördröjning kan ändras (ABV).
- Toppfart kan ändras.
- Inställning av lokparametrar (Adress, acceleration/ bromsfördröjning, toppfart): Via Control Unit, Mobile Station eller Central Station.
- Körriktningsberoende frontbelysning.
- Vid analog körning är endast den automatiska ljusväxlingsfunktionen tillgänglig.

Kopplingsbara funktioner					 Digital / Systems
Frontstrålkastare	function/off			Funktion f0	Funktion f0
Ljud: Stationsutrop	f1	Funktion 1	Funktion 5	Funktion f1	Funktion f1
Ljud: Trafikljud	f2	Funktion 2	Funktion 3	Funktion f2	Funktion f2
Ljud: Lokvissla	f3	Funktion 3	Funktion 4	Funktion f3	Funktion f3
ABV, från	f4	Funktion 4	Funktion 2	Funktion f4	Funktion f4
Ljud: Bromsgnissel, från	—	—	Funktion 6	Funktion f5	Funktion f5
Frontstrålkastare Förrarhytt 2 från	—	—	Funktion 1	Funktion f6	Funktion f6
Ljud: Konduktörvissla	—	—	Funktion 7	Funktion f7	Funktion f7
Frontstrålkastare Förrarhytt 1 från	—	—	Funktion 8	Funktion f8	Funktion f8
Ljud: Kompressor	—	—	—	Funktion f9	Funktion f9
Ljud: Tryckluftutsläpp	—	—	—	Funktion f10	Funktion f10
Rangerljus dubbel A	—	—	 + 1 + 8	f0 + f6 + f8	f0 + f6 + f8

## Vink om sikkerhed









- Lokomotivet må kun bruges med et driftssystem (Märklin AC, Märklin Delta, Märklin Digital eller Märklin Systems), der er beregnet dertil.
- Anvend kun DC-DC-omformere og transformatorer, der passer til den lokale netspænding.
- Lokomotivet må ikke forsynes fra mere end én strømkilde ad gangen.
- Vær under alle omstændigheder opmærksom på de vink om sikkerhed, som findes i brugsanvisningen for Deres driftssystem.
- Ved konventionel drift af lokomotivet skal tilslutningssporet støjdæmpes. Dertil skal anvendes støjdæmpningssættet 74046. Støjdæmpningssættet er ikke egnet til digital drift.
- **ADVARSEL!** Skarpe kanter og spidser pga. funktionen.
- Modellen må ikke udsættes for direkte sollys, store temperaturudsving eller høj luftfugtighed.
- Service, vedligeholdelse og reparationer må kun udføres af voksne.

## Vigtige bemærkninger

- Betjeningsvejledning og emballage hører til produktet og skal derfor gemmes og medfølge, hvis produktet gives videre til andre.
- For reparation eller reservedele bedes De henvende Dem til Deres Märklinforhandler.
- Garanti ifølge vedlagte garantibevis.
- <http://www.maerklin.com/en/imprint.html>

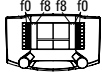
## Funktioner

- Registrering af driftsarten: automatisk.
- Indstillelige adresser:  
**1-80** (Control Unit 6021/Mobile Station 60651/652)  
**1-255** (Central Station 6021x/Mobile Station 60653)
- Adresse af fabrik: **10**
- Mfx-teknologi til Mobile Station / Central Station.  
Navn af fabrik: **E10 1309 DB**
- Indstillelig kørselsforsinkelse (ABV).
- Indstillelig bremseforsinkelse (ABV).
- Indstillelig maksimalhastighed.
- Indstilling af lokomotivparametrene (adresse, kørsels-/bremseforsinkelse, maksimalhastighed):  
Via Control Unit, Mobile Station eller Central Station.
- Køreretningsafhængig frontbelysning.
- I analogdrift er det kun køre- og lysskiftefunktionerne, der er tilgængelige.

Styrbare funktioner					 Digital / Systems
Frontbelysning	function/off			Funktion f0	Funktion f0
Lyd: Banegårdsmeddelelse	f1	Funktion 1	Funktion 5	Funktion f1	Funktion f1
Lyd: Driftslyd	f2	Funktion 2	Funktion 3	Funktion f2	Funktion f2
Lyd: Lokomotivfløjte	f3	Funktion 3	Funktion 4	Funktion f3	Funktion f3
ABV, fra	f4	Funktion 4	Funktion 2	Funktion f4	Funktion f4
Lyd: Pibende bremses fra	—	—	Funktion 6	Funktion f5	Funktion f5
Frontbelysning Kabine 2 fra	—	—	Funktion 1	Funktion f6	Funktion f6
Lyd: Billetkontrollørfløjt	—	—	Funktion 7	Funktion f7	Funktion f7
Frontbelysning Kabine 1 fra	—	—	Funktion 8	Funktion f8	Funktion f8
Lyd: Kompressor	—	—	—	Funktion f9	Funktion f9
Lyd: Udlledning af trykluft	—	—	—	Funktion f10	Funktion f10
Rangerlys dobbelt A	—	—	 + 1 + 8	f0 + f6 + f8	f0 + f6 + f8

<b>CV (Parameter) • CV (Parameter) • CV (Paramètre) • CV (Parameter) • CV (Parámetro) • CV (Parametro) • CV (Parameter) • CV (Parameter)</b>	<b>CV-Nr.</b>	<b>Wert • Value • Valeur • Waarde • Valor • Valore • Värde • Værði</b>
Adresse • Address • Adresse • Adres • Código • Indirizzo • Adress • Adresse	01	01 - (80)* 255
Anfahrverzögerung • Acceleration delay • Temporisation accélération • Optrekvertraging • Regulación arranque • Ritardo di avviamento • Igångsättningsreglering • Kørselsforsinkelse	03	01 - (63)* 255
Bremsverzögerung • Braking delay • Temporisation de freinage • Afremvertraging • Frenado lento • Ritardo di frenatura • Bromsfördröjning • Bremseforsinkelse	04	01 - (63)* 255
Höchstgeschwindigkeit • Maximum speed • Vitesse maximale • Maximumsneilheid • Velocidad máxima • Velocità massima • Toppfart • Maksimalhastighed	05	01 - (63)* 255
Rückstellen auf Serienwerte • Reset to series value • Remettre aux valeurs de série • Terugzetten naar serie-instellingen • Restablecer los valores de serie • Ripristinare sui valori di serie • Återställa till standardvärden • Tibagestil til serieværdien	08	08
Lautstärke • Volume • Volume haut-parleur • Volume • Volumen del sonido • Intensità del suono • Ljudstyrka • Lydstyrke	63	01 - (63)* 255

\* () = Control Unit 6021 / Mobile Station 60651/60652

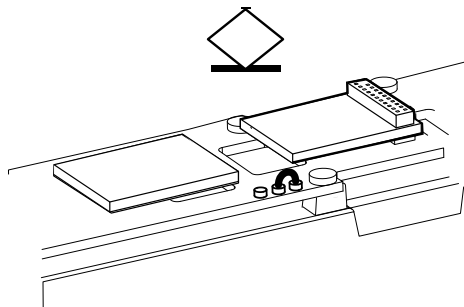
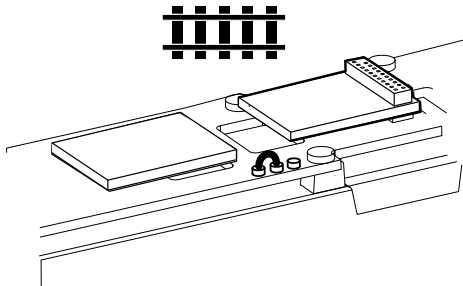
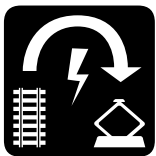

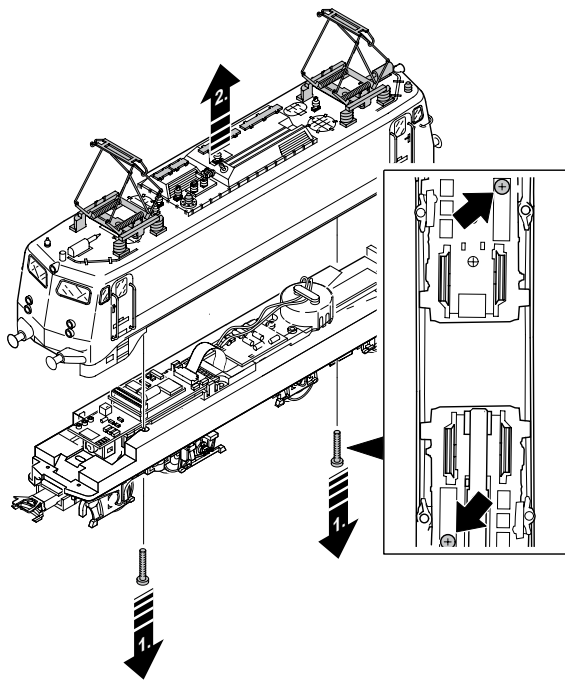



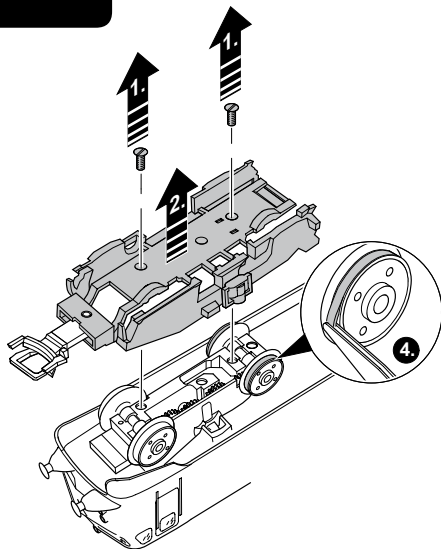
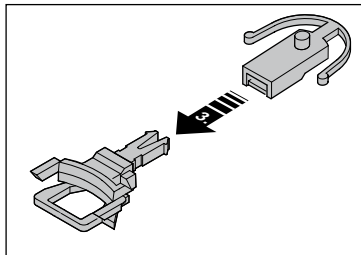
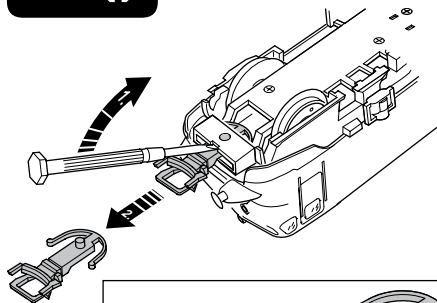

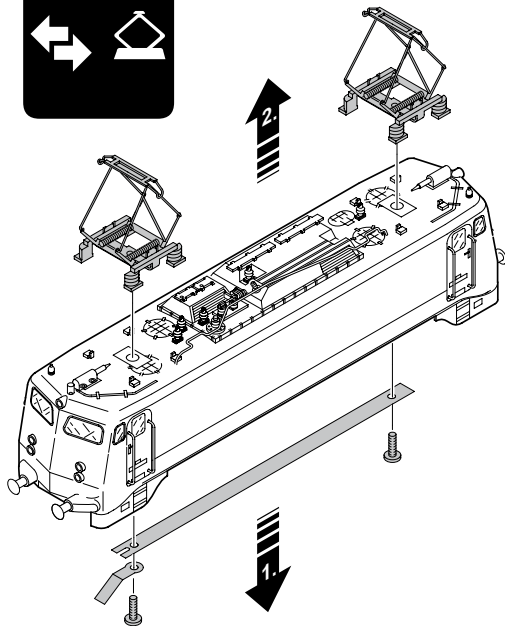
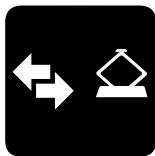
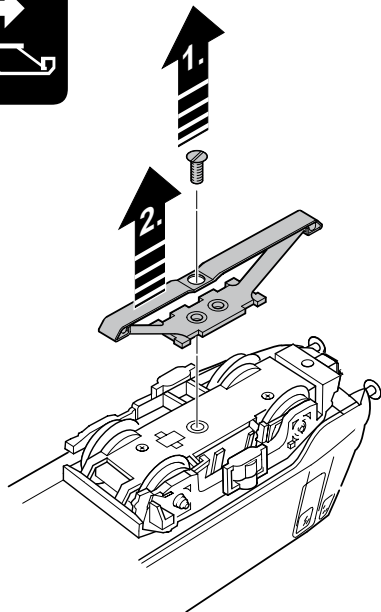
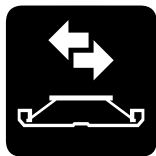

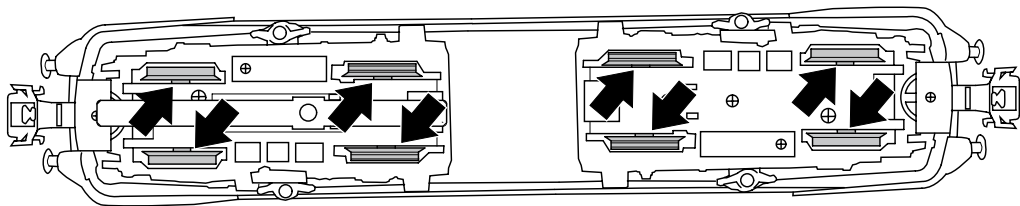

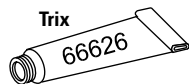
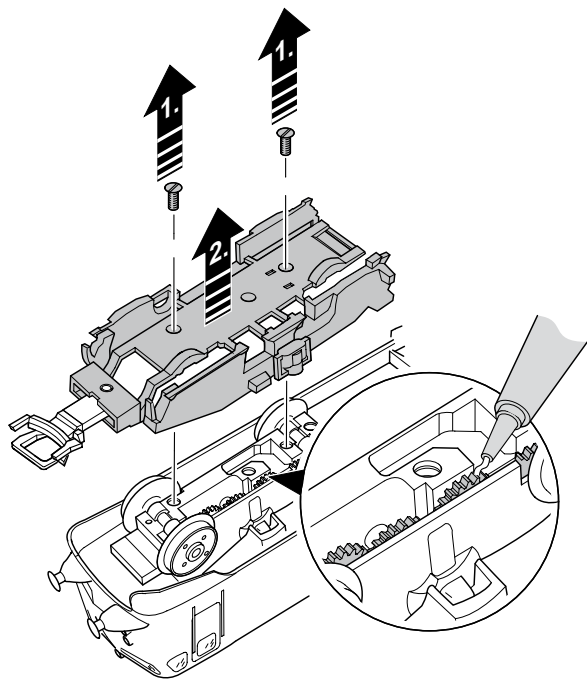

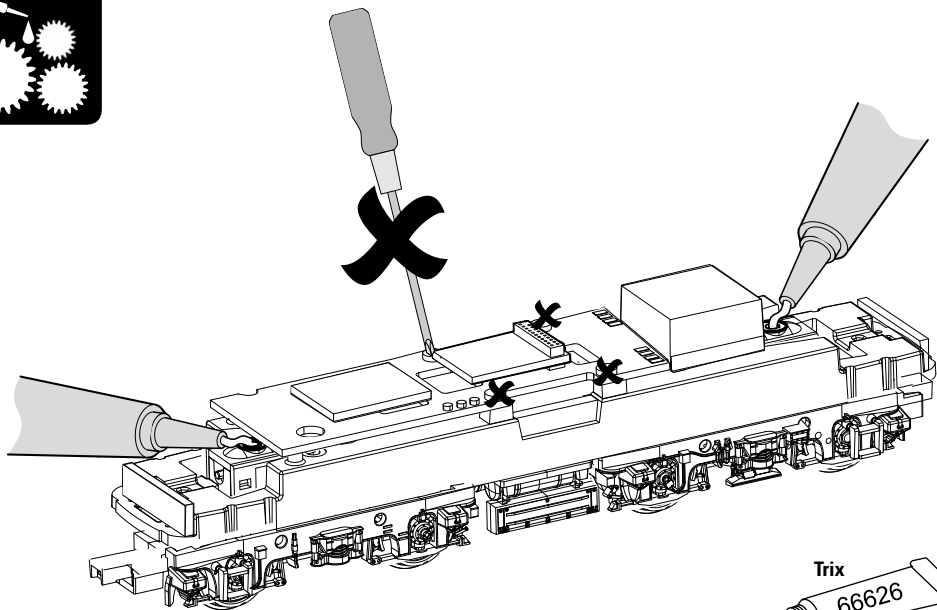

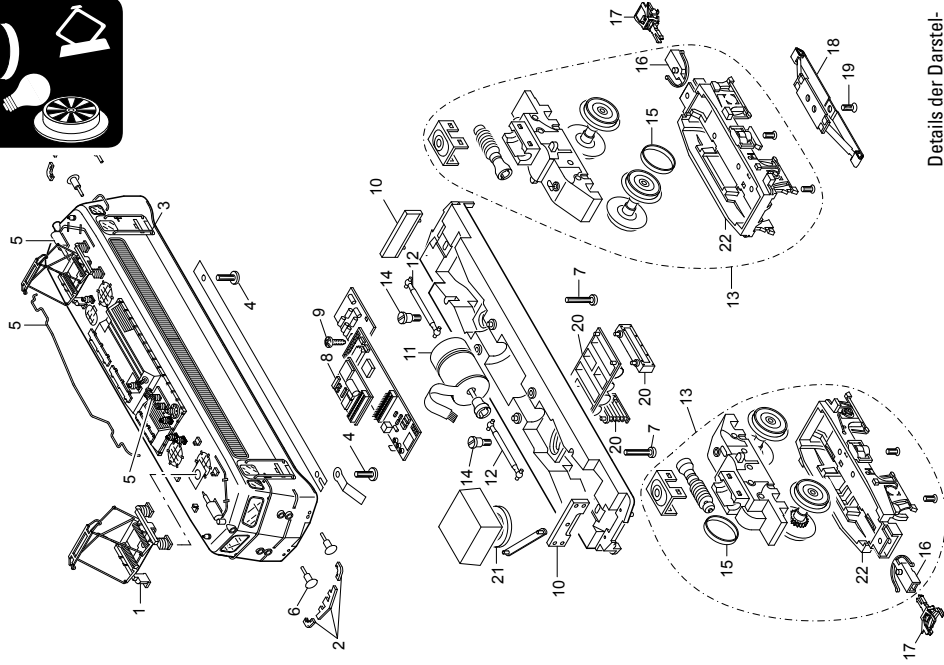

Details der Darstellung können von dem Modell abweichen.

1 Scherenstromabnehmer	E220 433
2 Tritte	E112 163
3 Griffstange	E211 110
4 Schraube	E785 340
5 Dachausrüstung	E111 664
6 Puffer	E198 544
7 Schraube	E786 870
8 Decoder	190 823
9 Schraube	E786 750
10 Beleuchtungseinheit	E132 288
11 Motor	E154 000
12 Kardanwelle	E411 243
13 Antriebseinheit	E165 570
14 Schraube	E753 030
15 Haftreifen	7 153
16 Kupplungsdeichsel	E101 975
17 Kurzkupplung	E701 630
18 Schleifer	7 185
19 Schraube	E786 790
20 Attrappe, Kühler, Batteriekasten	E182 577
21 Lautsprecher	E182 576
22 Drehgestellblenden	E199 056

Hinweis: Einige Teile werden nur ohne oder mit anderer Farbgebung angeboten.

Teile, die hier nicht aufgeführt sind, können nur im Rahmen einer Reparatur im Märklin-Reparatur-Service repariert werden.

Due to different legal requirements regarding electro-magnetic compatibility, this item may be used in the USA only after separate certification for FCC compliance and an adjustment if necessary. Use in the USA without this certification is not permitted and absolves us of any liability. If you should want such certification to be done, please contact us – also due to the additional costs incurred for this.

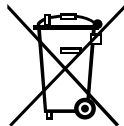

Gebr. Märklin & Cie. GmbH  
Stuttgarter Str. 55 - 57  
73033 Göppingen  
Germany  
[www.maerklin.com](http://www.maerklin.com)

  
[www.maerklin.com/en/imprint.html](http://www.maerklin.com/en/imprint.html)

190822/0113/Sm2Ef  
Änderungen vorbehalten  
© by Gebr. Märklin & Cie. GmbH