

RÜBENVERLADUNG MIT LAGERSCHUPPEN



BEET DUMP WITH STORAGE SHED

CHARGEMENT DE BETTERAVES AVEC ENTREPÔT

LAAD- EN LOSPLAATS VOOR BIETEN MET OPSLAGLOODS

Art. Nr. 130184

D

Vor Beginn des Bastelns sollten Sie sich mit den Spritzlingen und der Anleitung vertraut machen. Sollte es einmal vorkommen, dass ein Teil im Bausatz fehlt, kreuzen Sie bitte das fehlende Teil in der Anleitung an und schicken Sie diese bitte an Fa. Gebr. FALLER GmbH, Abt. Kundendienst, kundendienst@faller.de, Kreuzstraße 9, 78148 Gütenbach. Sie erhalten dann umgehend Ersatz. Es kann vorkommen, dass bei einem Bausatz Einzelteile übrig sind.

GB

Before beginning with the assembly please familiarize yourself with the parts and read the instructions carefully. In case of missing parts please indicate these on the instructions leaflet with a circle and return the leaflet to Gebr. FALLER GmbH, kundendienst@faller.de, Kreuzstraße 9, D-78148 Gütenbach, Germany. You will receive the replacement by return. It may happen in a kit that some parts are not required.

F

Avant de commencer le montage de votre maquette bien lire la notice et repérer les grappes. Si une pièce manque dans une boîte, cochez la pièce correspondante sur la notice et renvoyez-la-nous à Gebr. FALLER GmbH, kundendienst@faller.de, Kreuzstraße 9, D-78148 Gütenbach (R.F.A.). Nous vous ferons parvenir la pièce par retour. Dans certains kits, il est possible que certaines pièces ne soient pas utilisées.

NL

Vóór het bouwen zou men de gietstukken en de handleiding moeten bestuderen. Indien onverhoopt een onderdeel aan het bouwpakket ontbreekt, gelieve men het ontbrekende deel in de handleiding aan te kruisen en deze te zenden aan Gebr. FALLER GmbH, kundendienst@faller.de, Kreuzstraße 9, D-78148 Gütenbach. U ontvangt dan omgaand en gratis het ontbrekende onderdeel. Het kan voorkomen dat u bij bepaalde bouwdozen onderdelen overhoudt.

Für den Zusammenbau des Modells empfehlen wir folgende FALLER-Artikel (sind nicht im Bausatz enthalten):

For the assembly of the kit we recommend following FALLER products (not included in the kit):

Pour l'assemblage du modèle, nous vous recommandons les articles FALLER suivants (non inclus dans le kit):

Om dit model te bouwen adviseren wij de volgende FALLER producten (maken geen deel uit van deze bouwset):



Art. Nr. 170492
FALLER-EXPERT

Flüssigkleber in Plastikflasche mit Spezialkanüle für feinste Klebstoffdosierung.

Liquid cement in plastic bottle with canule for very fine dosage.

Celle liquide en bouteille plastique avec bec verseur pour un dosage précis.

Vloeibare lijm in plastic-flescon met doseerbuisje om nauwkeurig te lijmen.



Art. Nr. 170688
SPEZIAL-SEITENSCHNEIDER

zum geratfreien Abtrennen von feinsten Spitzteilen.
Nur für Polystyrol geeignet.

Special side cutter for cutting off ultra-fine moulded parts without burrs. Only suitable for polystyrene.

Pince coupante spéciale pour couper sans bavure les pièces miniatures moulées par injection. Convient uniquement au polystyrène.

Speciale zijknijptang voor het braamloos afknippen van de fijnste gietstukdelen. Alleen geschikt voor polystyrol.

ajckids.com
plans & models for mobiles

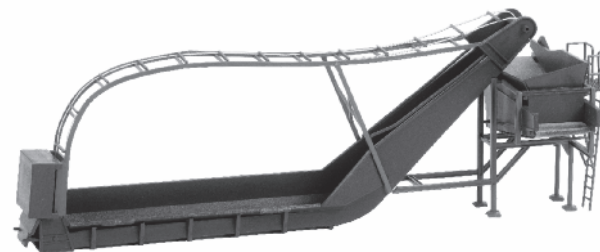
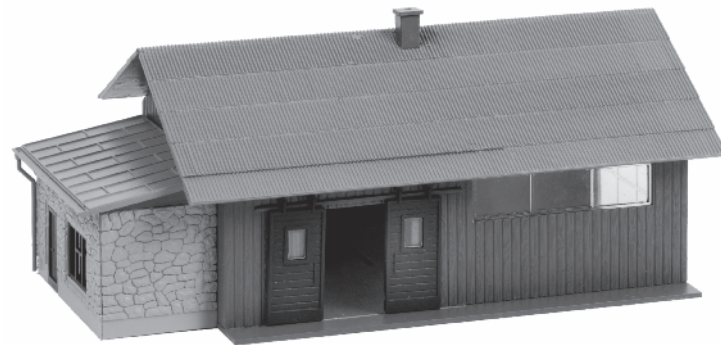

Inhalt	Spritzlinge	1 A	1 x	4	1 x	1	1 x
Contents	Sprues	2 B	1 x	5	1 x	2	1 x
Contenu	Moulages	3	1 x	6	1 x	D 2	1 x
Inhoud	Gietstukken						

Sa. Nr. 130 184 1

2

3/1

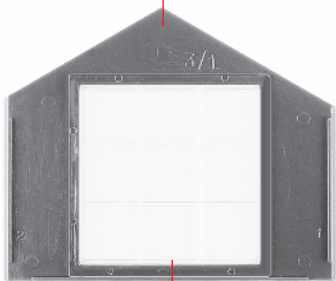

(A)

6/1

6/4

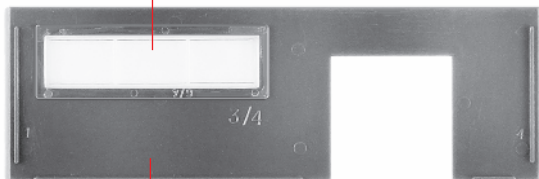

(B)

3/4

6/2

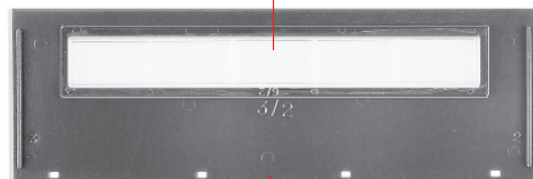

(C)

3/2

3/3

(C)

(A)

(B)

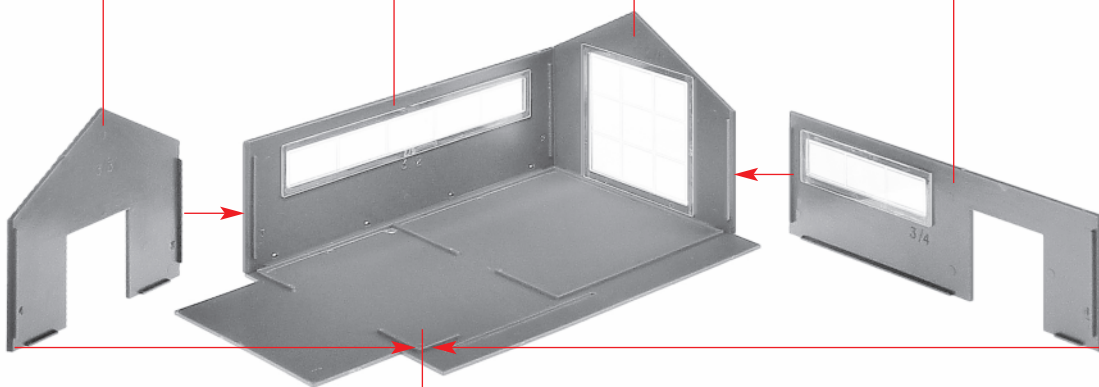

(D)

1/1

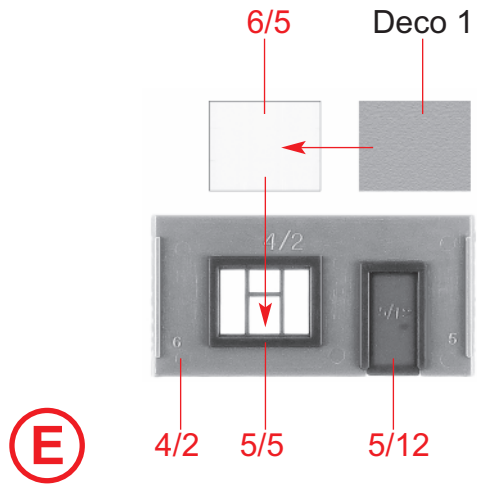

E

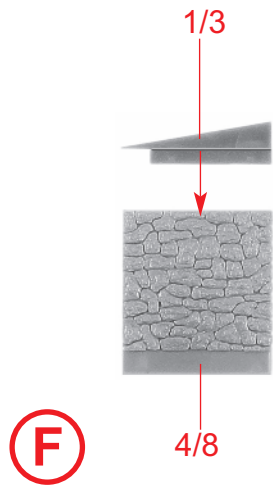

F

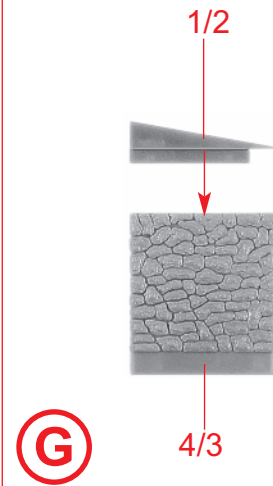

G

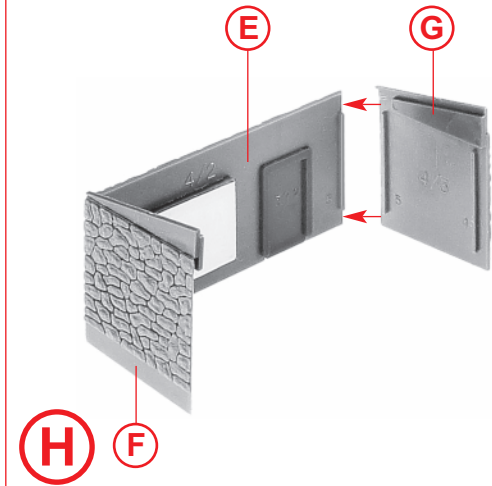

H

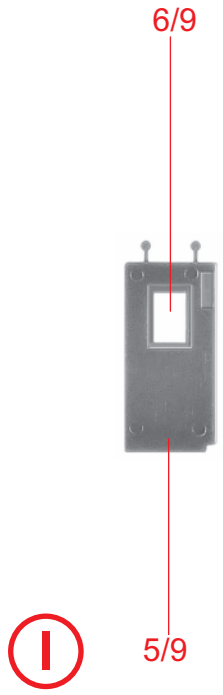

I

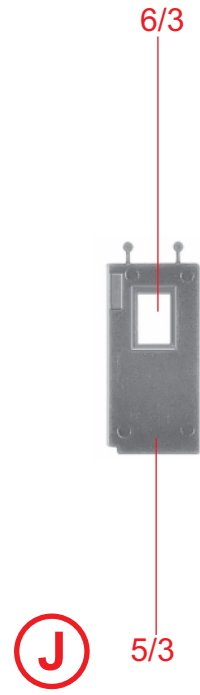

J

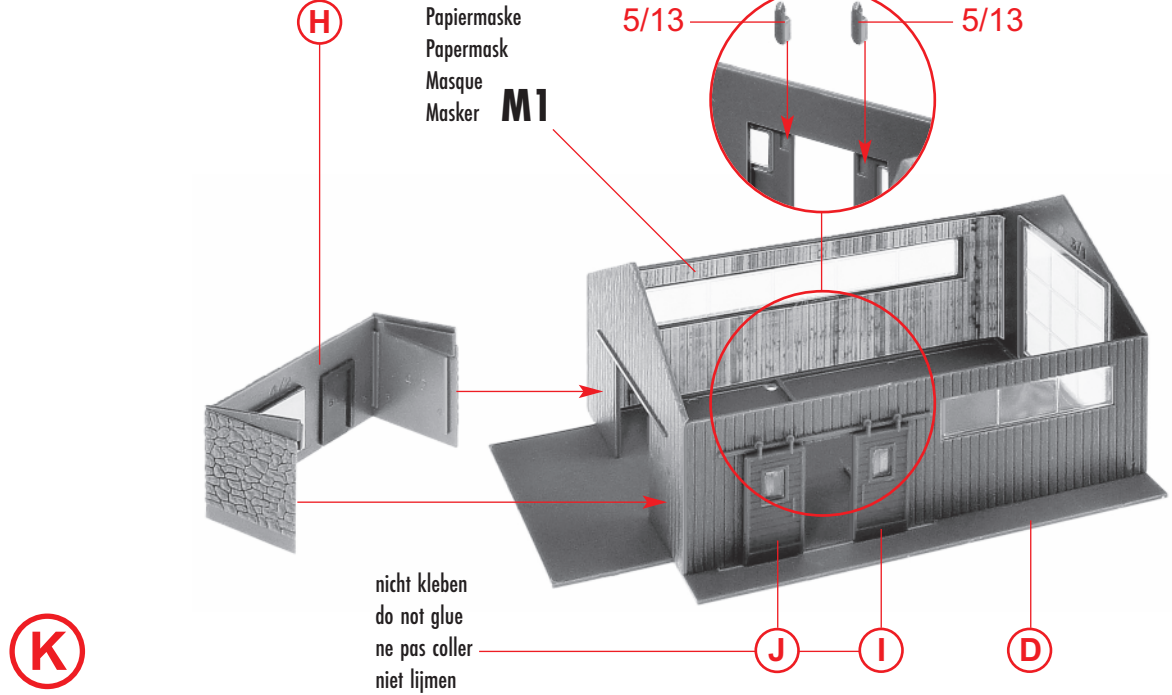

K

4

(K)

Papiermaske
Papermask
Masque
Masker **M2**

2/18

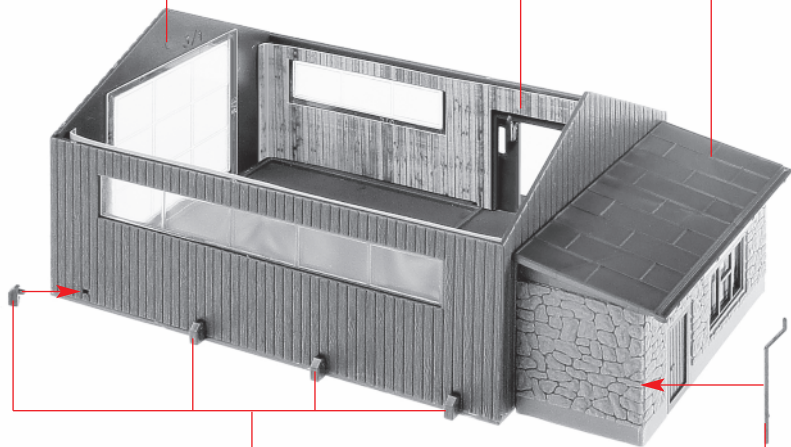

(L)

1/4

2/23

Papiermaske
Papermask
Masque
Masker **M3**

Papiermaske
Papermask
Masque
Masker **M4**

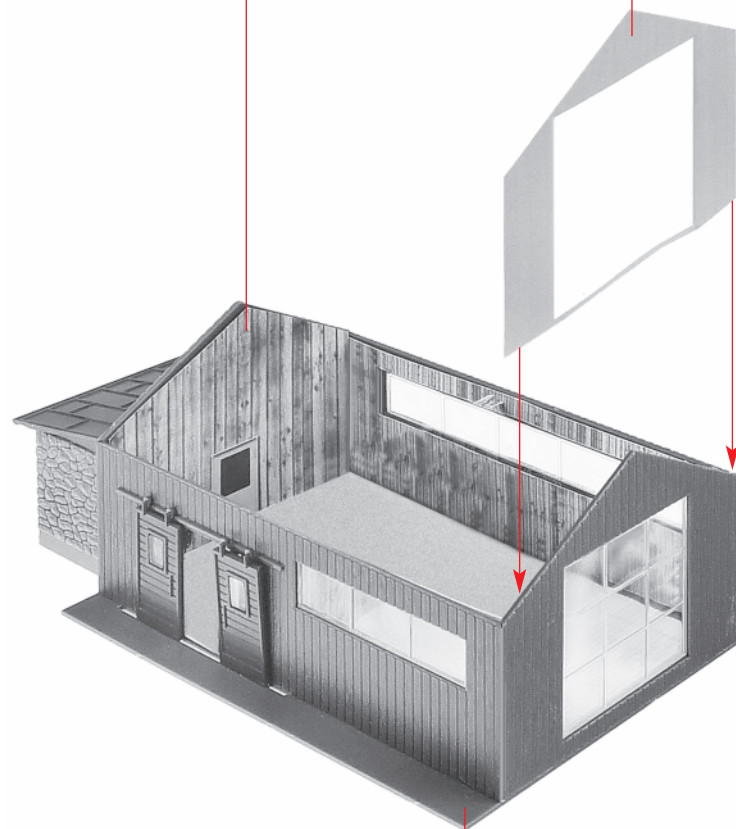

(M)

(L)

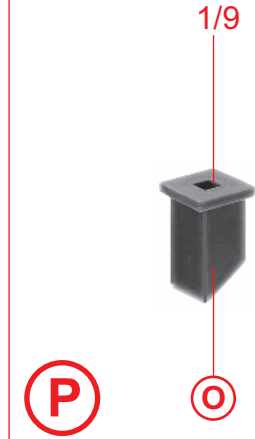
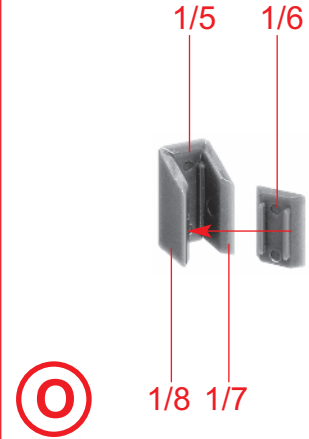
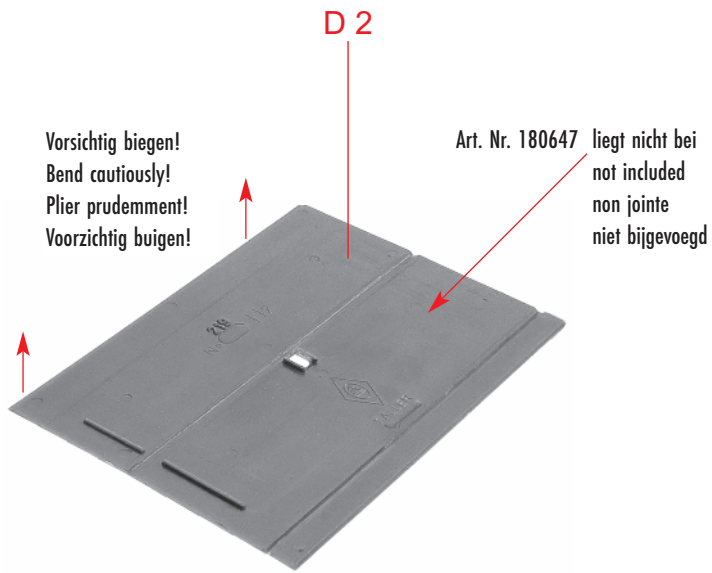

Ⓞ

Ⓟ

Ⓞ

M 1:1



Ⓝ

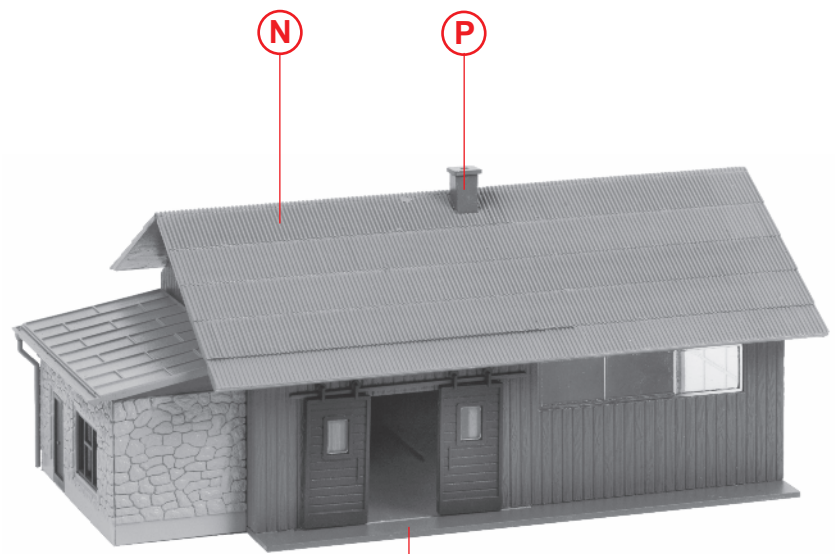

Ⓞ

Ⓜ

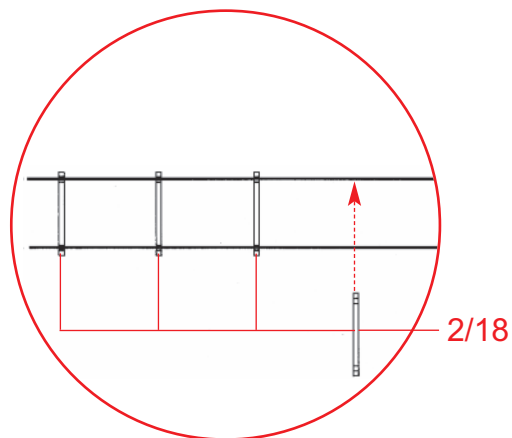

- (D)** Montage Transportband
Fäden mit Klebeband auf der Skizze fixieren. Sprossen 2/18 unter die Fäden schieben und von oben mit Sekundenkleber festkleben.
Vorsicht: Fäden nicht auf die Anleitung kleben!

- (GB)** Conveyor belt mounting
Fix threads with adhesive tape to sketch. Slide rungs 2/18 under the threads and fix them from above with split-second cement.
Make sure that the threads are not fixed to the surface on which the mounting instructions are printed.

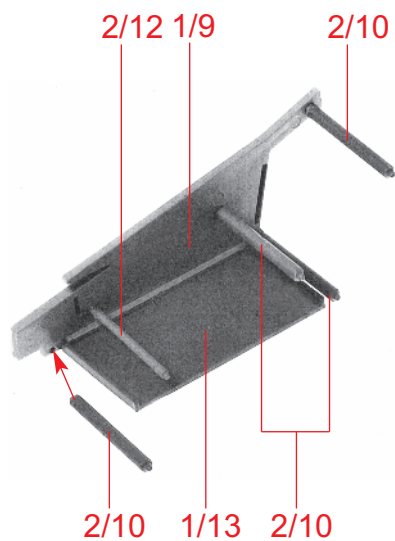
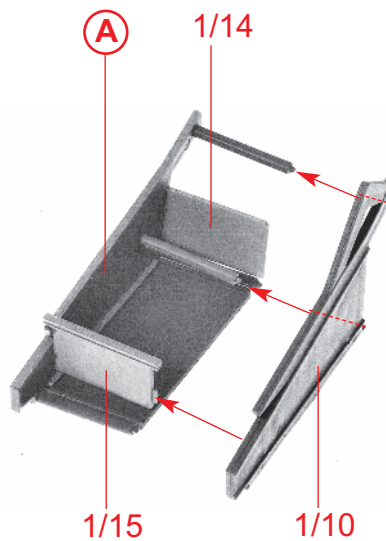
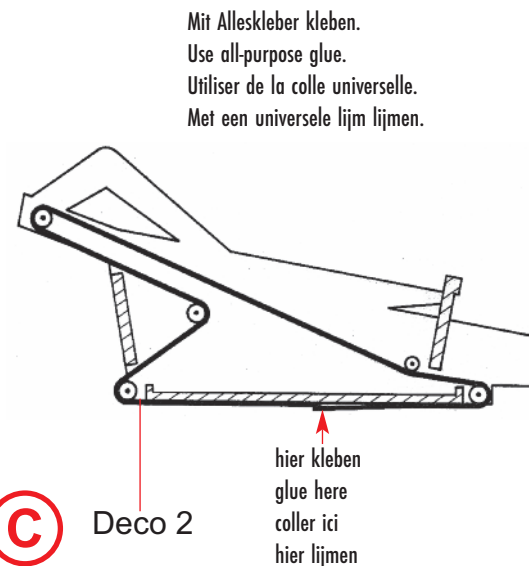
**(A)****(B)****(C)**

Mit Alleskleber kleben.
Use all-purpose glue.
Utiliser de la colle universelle.
Met een universele lijm lijmen.

- (F)** Montage bande de transport
 Fixer les fils sur le croquis avec le ruban adhésif. Glisser les barreaux 2/18 sous le fils et les coller du haut avec la colle rapide.
 Attention: Ne pas coller les fils sur les instructions montage.

- (NL)** Montage van de transportband
 Draden met plakband op de tekening vastplakken. Sporten 2/18 onder de draden schuiven en van bovenaf met secondelijm vastlijmen.
 Pas op: draden niet op de handleiding plakken.

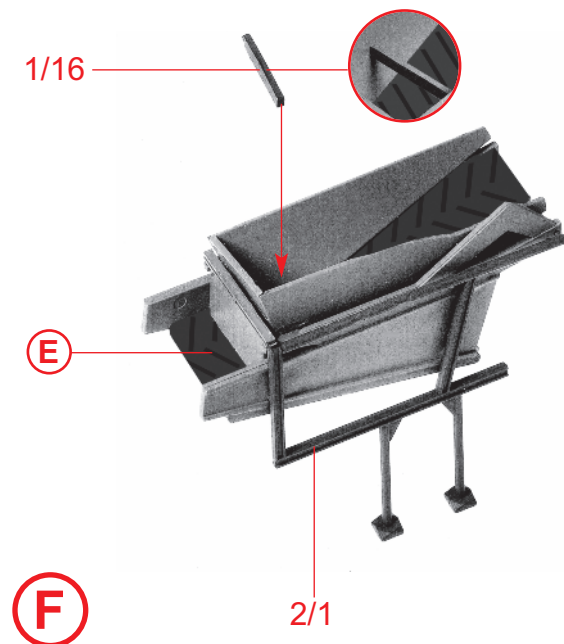
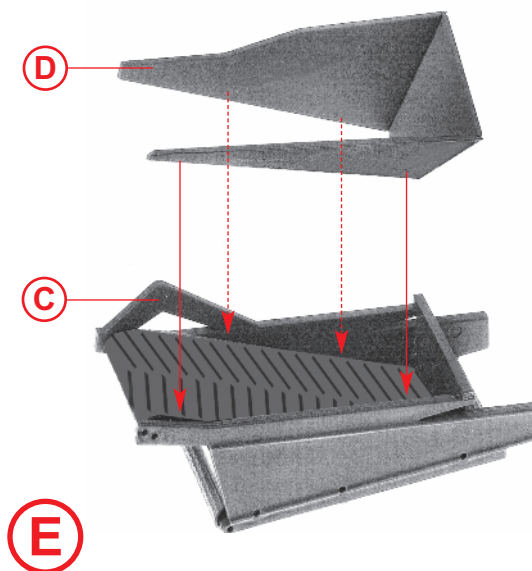
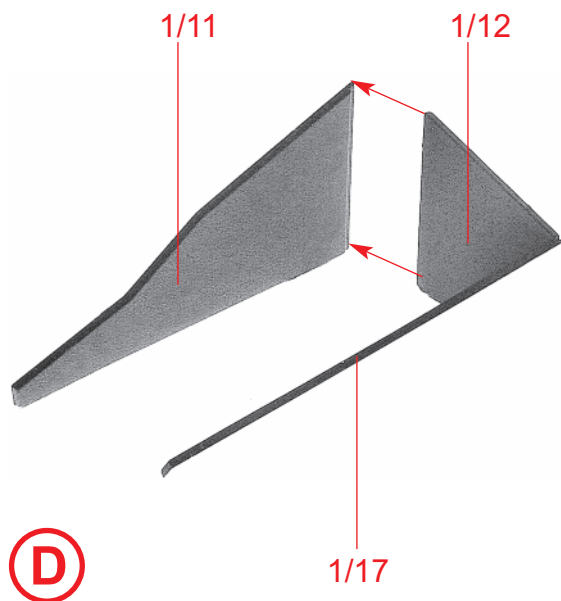

8

F

2/2

2/4

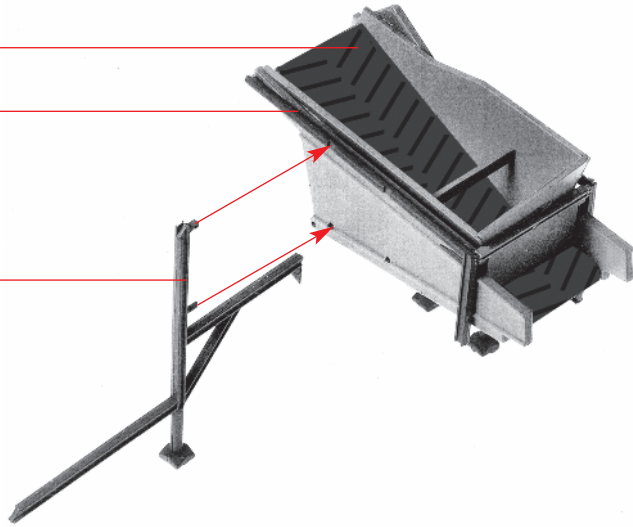

G

2/5

2/9

H

2/11

2/3

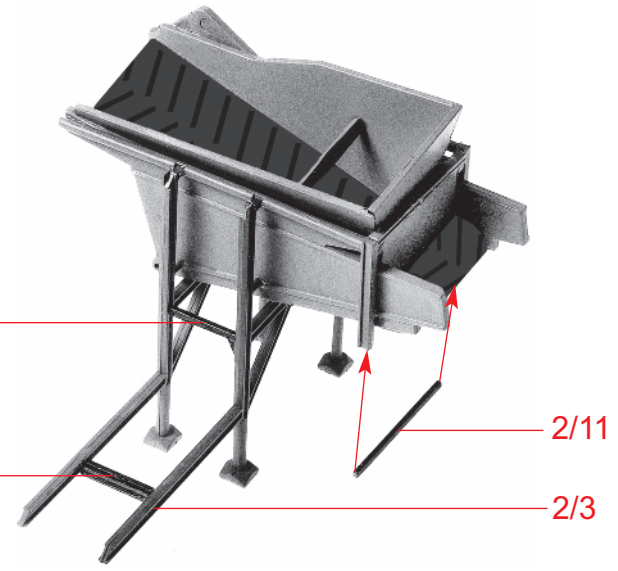

2/7

2/7

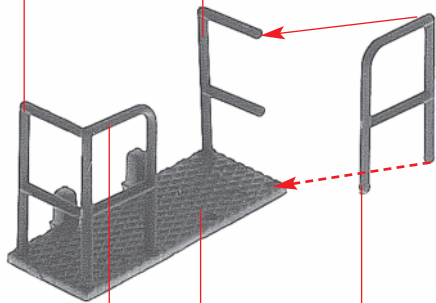

2/6

1/8

2/6

I

H

I

2/8

2/13

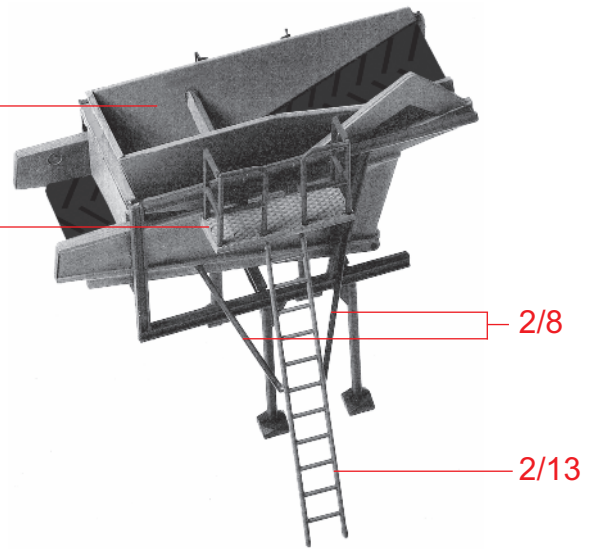

J

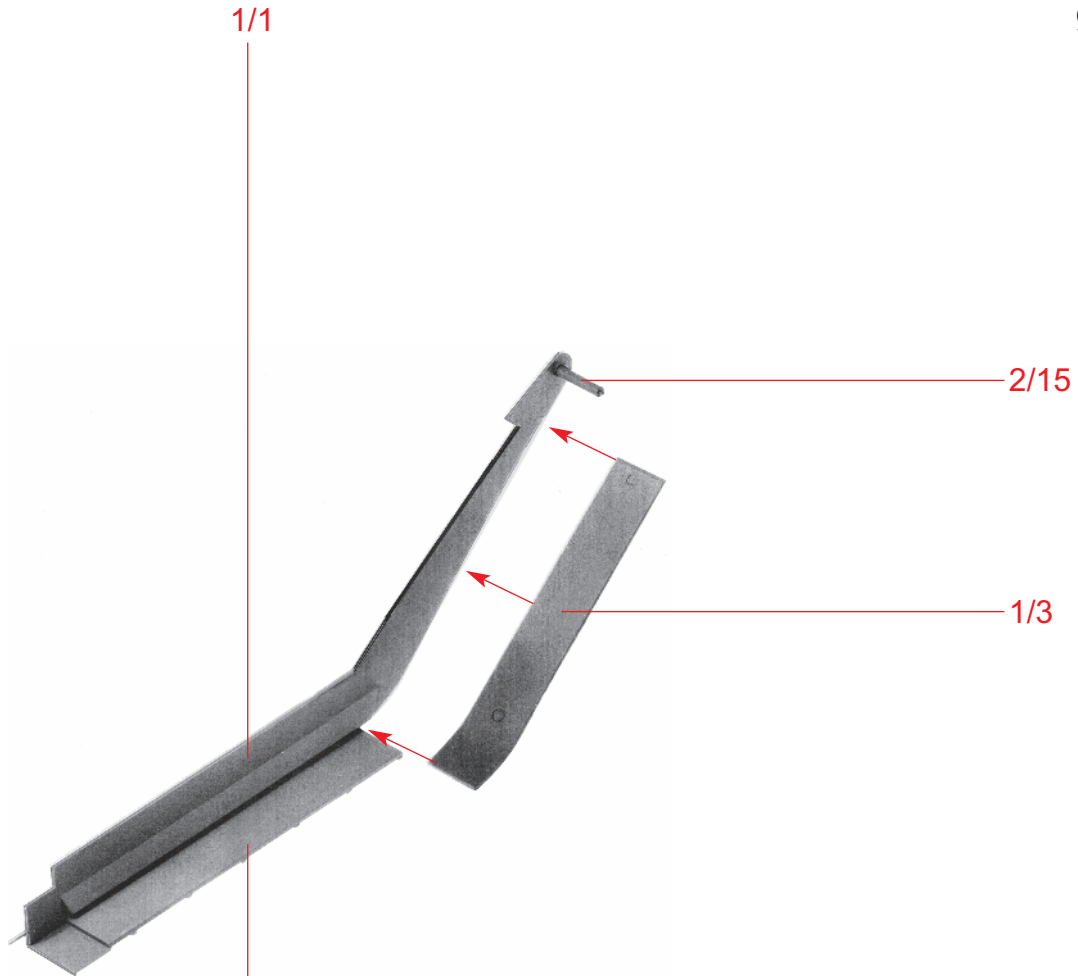

1/1

2/15

1/3

1/2



10

K

Montage Transportband

Conveyor belt mounting

Montage bande de transport

Montage van de transportband



hier kleben
glue here
coller ici
hier lijmen

1/5

2/17

Vorsichtig biegen!
Bend cautiously!
Plier prudemment!
Voorzichtig buigen!

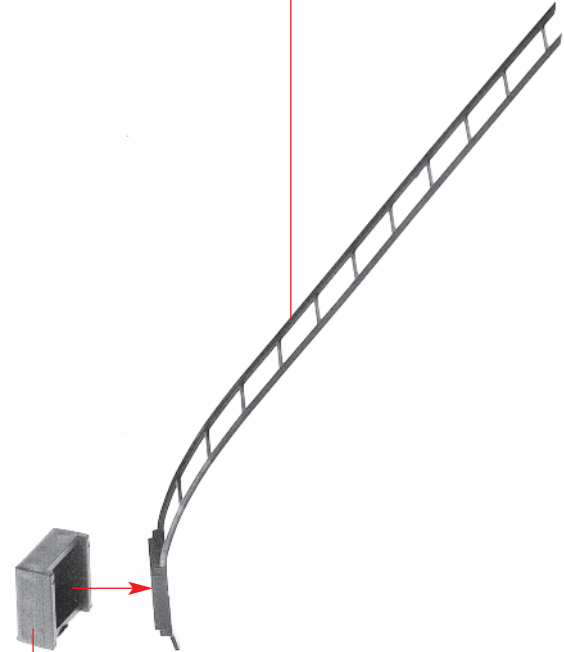

M

1/7

L

M

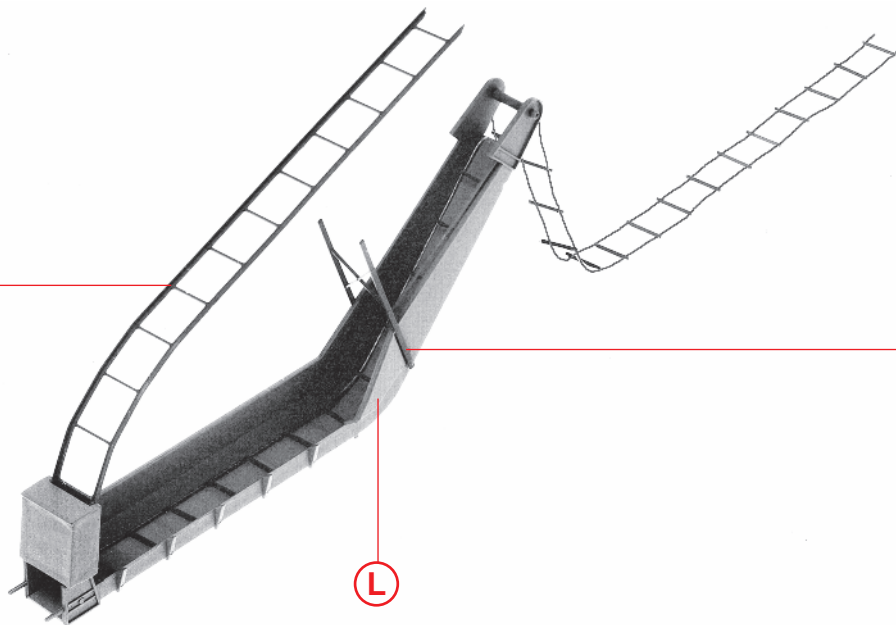

2/14

N

L

hier kleben
glue here
coller ici
hier lijmen

O

1/4

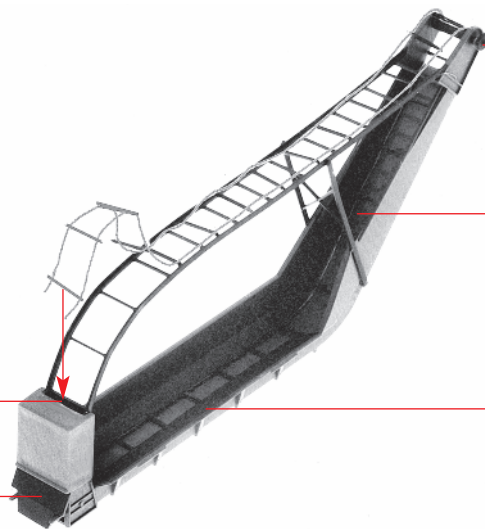

2/16

N

1/6

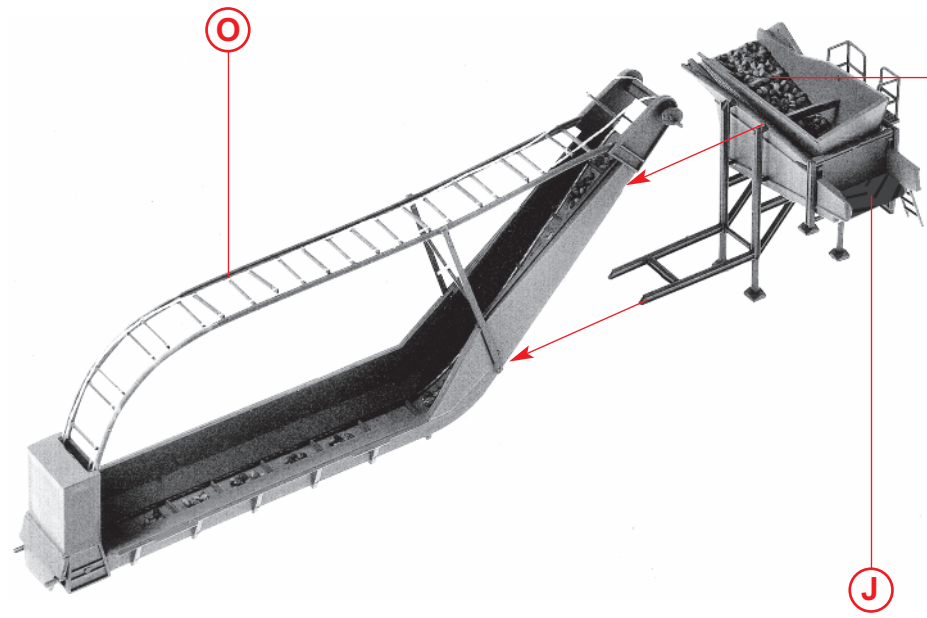

Inhalt	Tüte	Contents	bag
Contenu	sachet	Inhoud	zakje

P

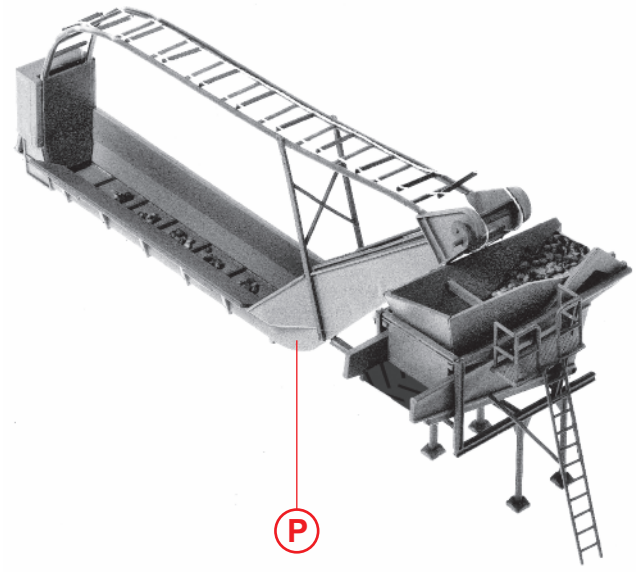

Q