

GROSSBEKOHLUNGSANLAGE

COALING STATION

GRAND CHARGEUR DE CHARBON

GROTE BEKOLINGSINSTALLATIE



Art. Nr. 120148

D

Vor Beginn des Bastelns sollten Sie sich mit den Spritzlingen und der Anleitung vertraut machen. Sollte es einmal vorkommen, dass ein Teil im Bausatz fehlt, kreuzen Sie bitte das fehlende Teil in der Anleitung an und schicken Sie diese bitte an Fa. Gebr. FALLER GmbH, Abt. Kundendienst, kundendienst@faller.de, Kreuzstraße 9, 78148 Gütenbach. Sie erhalten dann umgehend Ersatz.

GB

Before beginning with the assembly please familiarize yourself with the parts and read the instructions carefully. In case of missing parts please indicate these on the instructions leaflet with a circle and return the leaflet to Gebr. FALLER GmbH, kundendienst@faller.de, Kreuzstraße 9, D-78148 Gütenbach, Germany. You will receive the replacement by return.

F

Avant de commencer le montage de votre maquette bien lire la notice et repérer les grappes. Si une pièce manque dans une boîte, cochez la pièce correspondante sur la notice et renvoyez-la-nous à Gebr. FALLER GmbH, kundendienst@faller.de, Kreuzstraße 9, D-78148 Gütenbach (R.F.A.). Nous vous ferons parvenir la pièce par retour.

NL

Vóór het bouwen zou men de gietsstukken en de handleiding moeten bestuderen. Indien onverhoopt een onderdeel aan het bouwpakket ontbreekt, gelieve men het ontbrekende deel in de handleiding aan te kruisen en deze te zenden aan Gebr. FALLER GmbH, kundendienst@faller.de, Kreuzstraße 9, D-78148 Gütenbach. U ontvangt dan omgaand en gratis het ontbrekende onderdeel.

Für den Zusammenbau des Modells empfehlen wir folgende FALLER-Artikel (sind nicht im Bausatz enthalten):
For the assembly of the kit we recommend following FALLER products (not included in the kit):
Pour l'assemblage du modèle, nous vous recommandons les articles FALLER suivants (non inclus dans le kit):
Om dit model te bouwen adviseren wij de volgende FALLER producten (maken geen deel uit van deze bouwset):



Art. Nr. 170492
FALLER-EXPERT
Flüssigkleber in Plastikflasche mit Spezialkanüle für Feinste Klebstoffdosierung.
Liquid cement in plastic bottle with canule for very fine dosage.
Colle liquide en bouteille plastique avec bec verseur pour un dosage précis.
Vloeibare lijm in plastic-flescon met doseerbuisje om nauwkeurig te lijmen.



Art. Nr. 170688
SPEZIAL-SEITENSCHNEIDER
zum gratfreien Abtrennen von feinsten Spritzteilen.
Nur für Polystyrol geeignet.
Special side cutter for cutting off ultra-fine moulded parts without burrs.
Only suitable for polystyrene.
Pince coupante spéciale pour couper sans bavure les pièces miniatures moulées par injection. Convient uniquement au polystyrène.
Speciale zijkniptang voor het braamloos afknippen van de fijnste gietsukdelen. Alleen geschikt voor polystyrol.



Inhalt	Spritzlinge	1	1 x	4	1 x	7	2 x	10	2 x
Contents	Sprues	2	1 x	5	1 x	8	1 x	11	1 x
Contenu	Moulages	3	1 x	6	1 x	9	1 x		
Inhoud	Gietsstukken								

Sa. Nr. 144 720 0

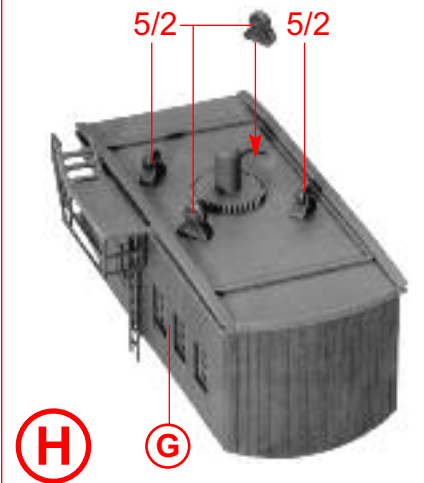
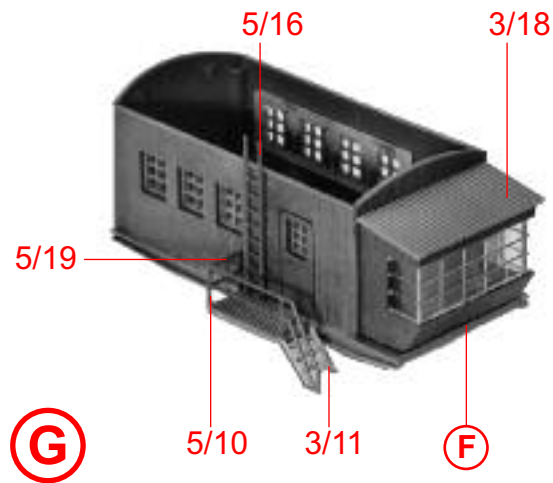
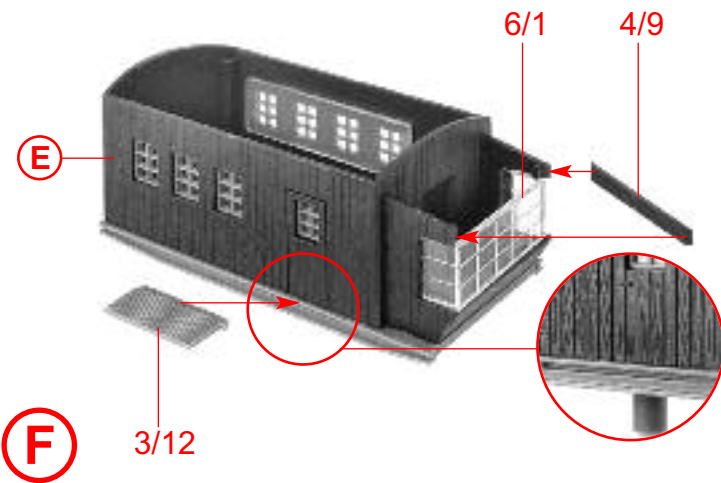
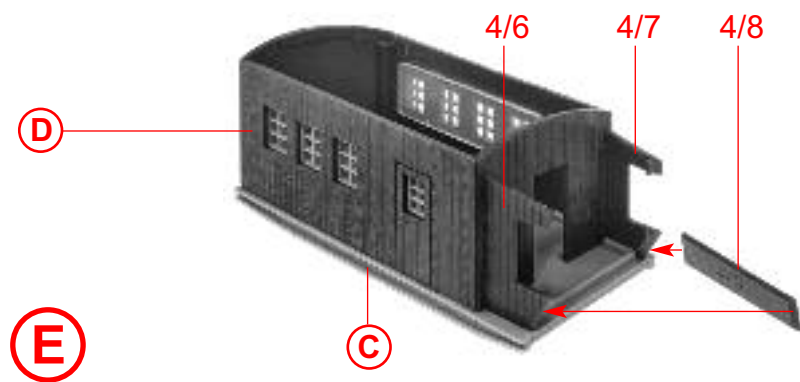
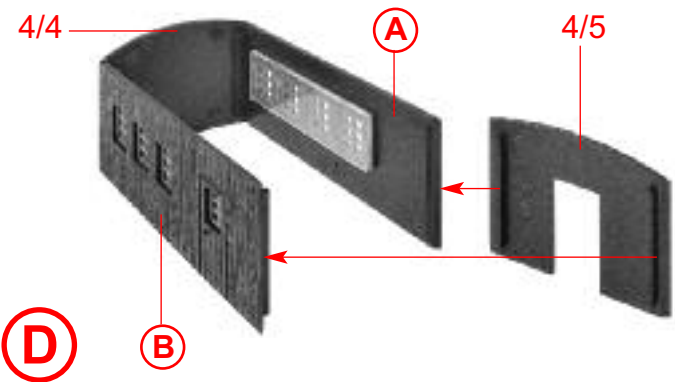
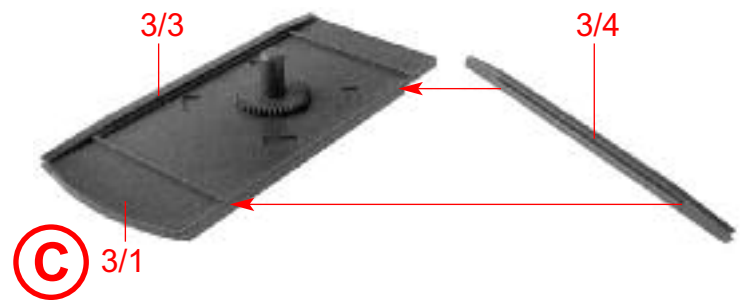
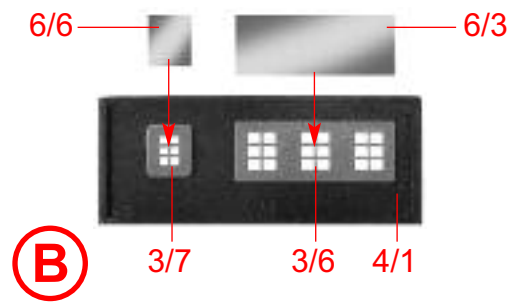
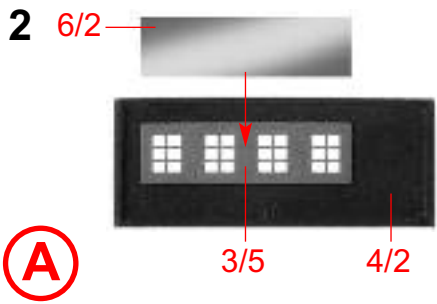

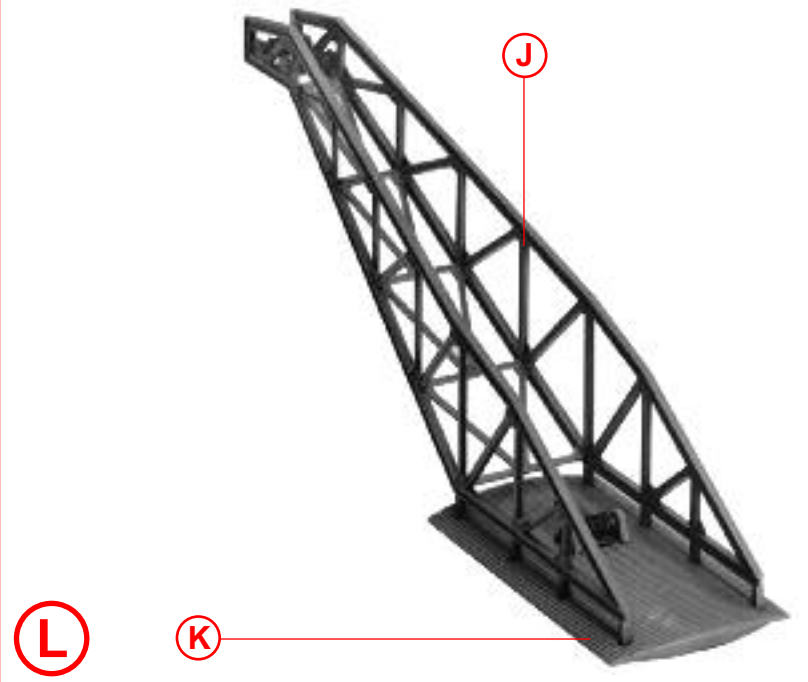
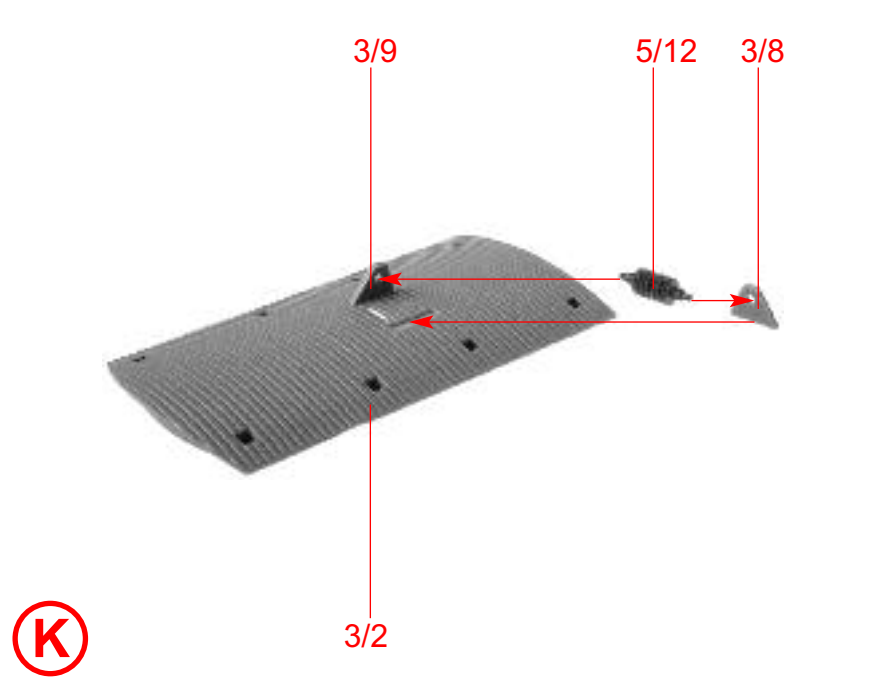
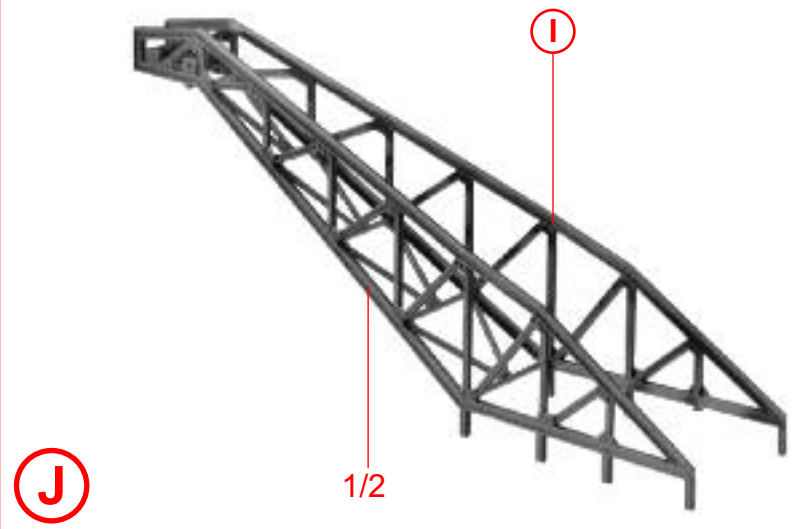
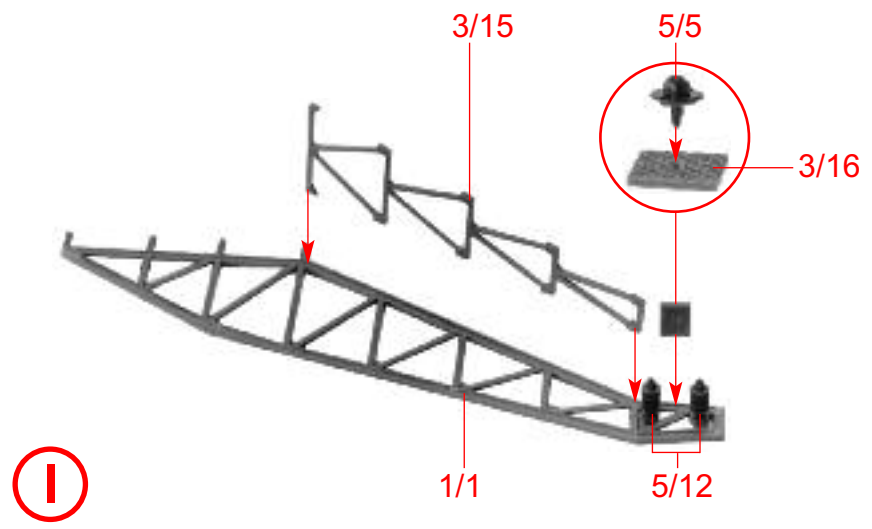

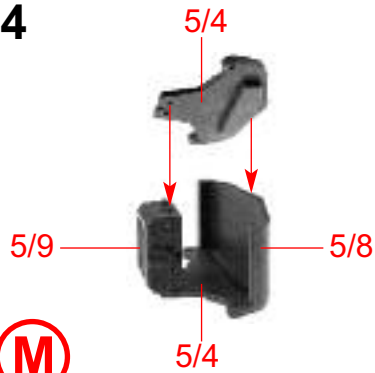
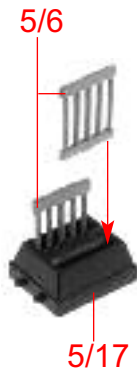
4**(M)****(N)**

Faden liegt nicht bei
4 x 350 mm.
Cord not included.
Aiguillée non jointe.
Garen niet bijgevoegd.

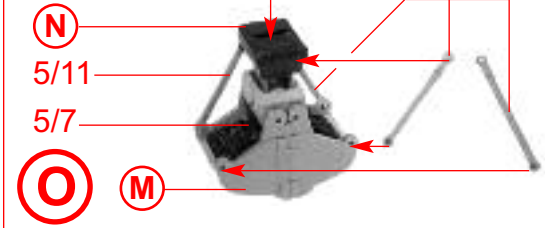
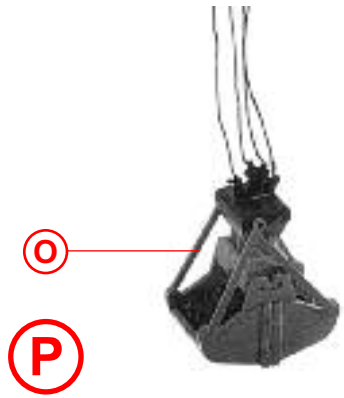
**(O)****(P)**

Sekundenkleber (FALLER EXPERT rapid 170500) verwenden.
Use instant modelling cement (FALLER EXPERT rapid 170500).
Utilisez la colle rapide (FALLER EXPERT rapid 170500).
Gebruik secondenlijm (FALLER EXPERT rapid 170500).

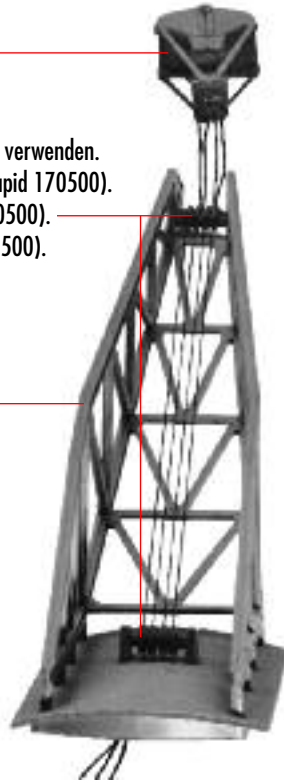
(L)**(Q)****(Q)**

Sekundenkleber (FALLER EXPERT rapid 170500) verwenden.
Use instant modelling cement (FALLER EXPERT rapid 170500).
Utilisez la colle rapide (FALLER EXPERT rapid 170500).
Gebruik secondenlijm (FALLER EXPERT rapid 170500).

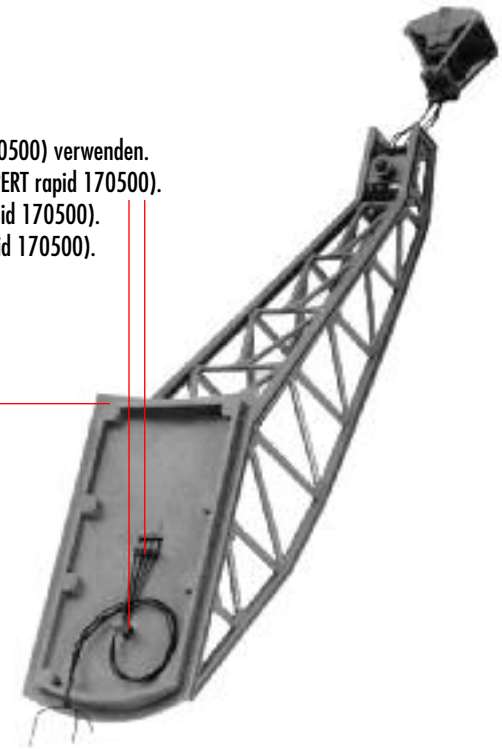
(R)

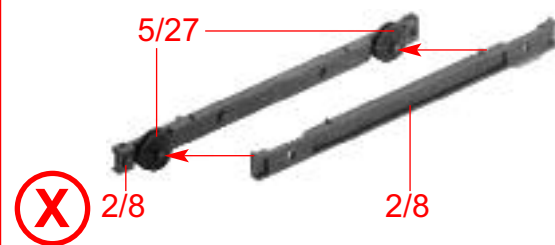
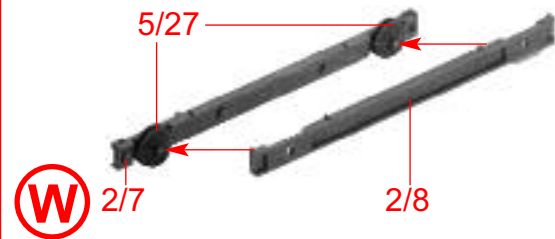
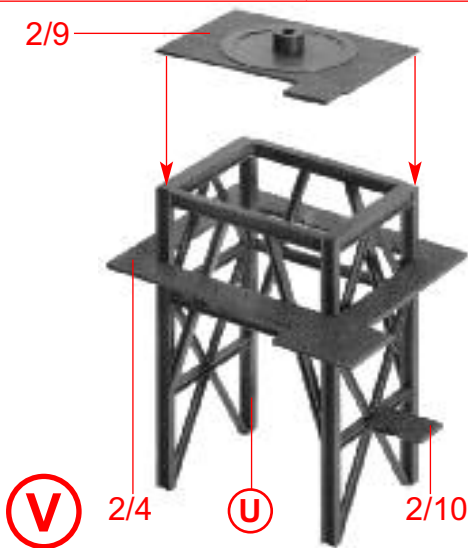
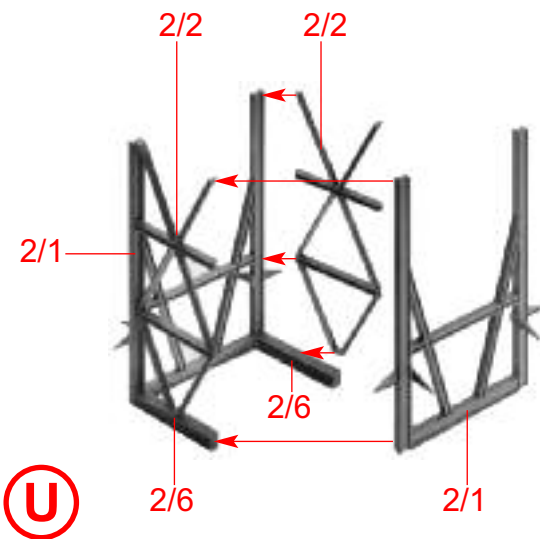
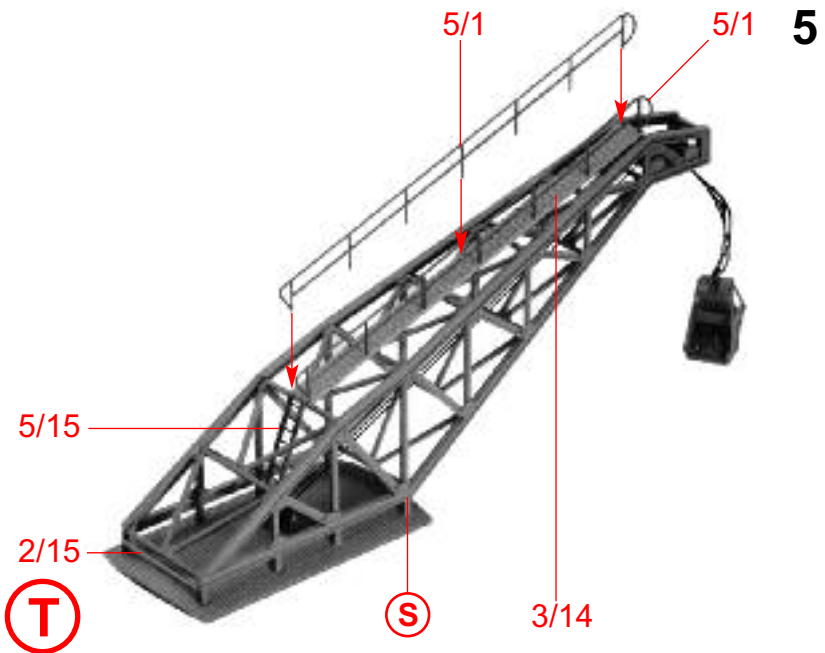
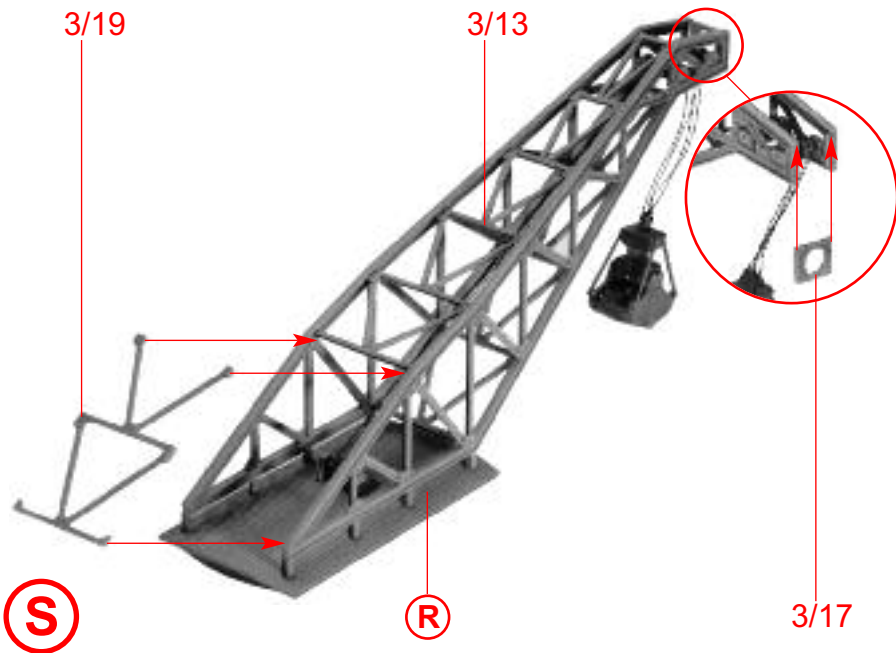

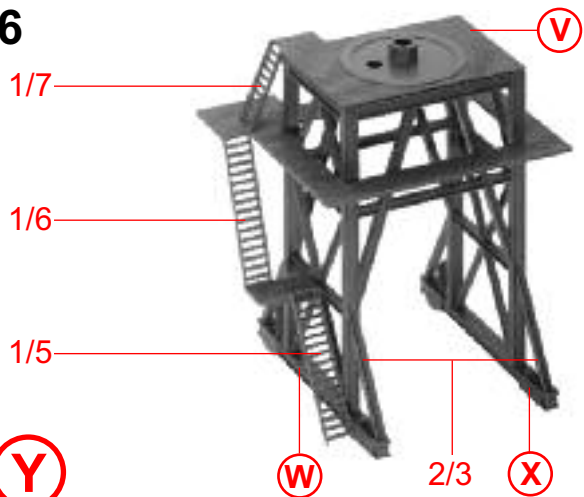
6

Einbaumöglichkeit für
Motor 180629 siehe Seite 7.

Possibilities to install
motor 180629 see page 7.

Possibilités de montage pour
le moteur 180629, voir page 7.

Inbouwmogelijkheid voor
motor 180629, zie blz. 7.

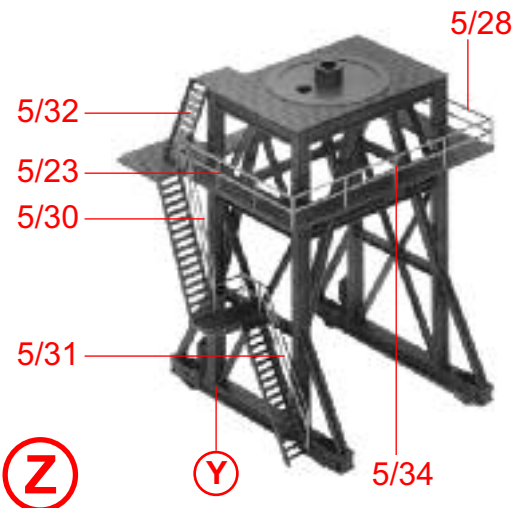

5/25

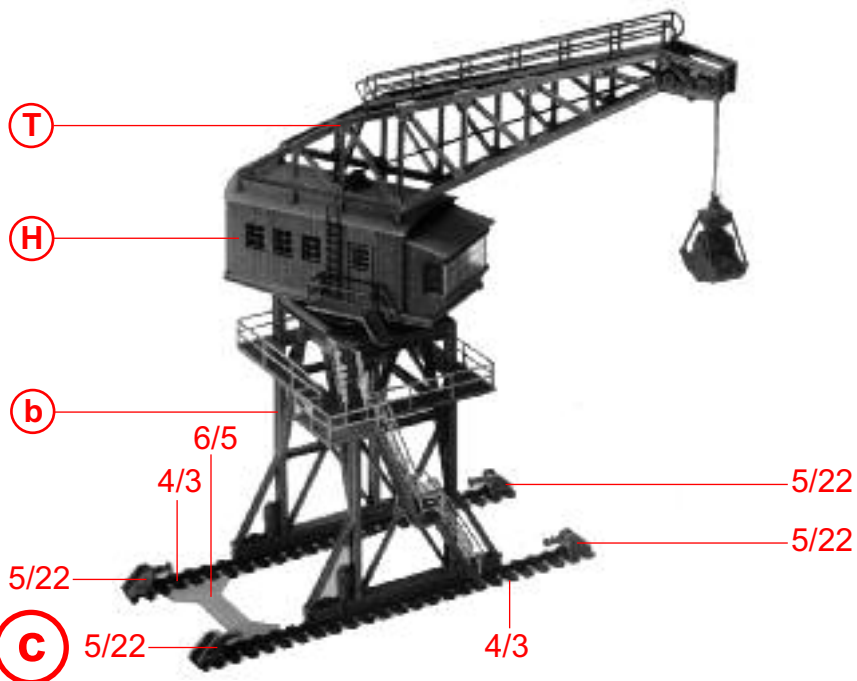
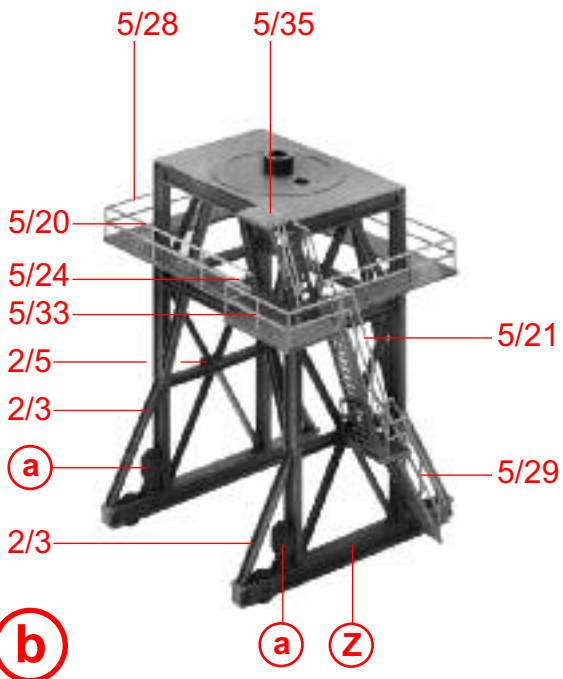

a 2 x 5/26

b

c

Motordrehrichtung

1. Der Motor kann durch den Schalter (Teil 1) auf Links- oder Rechtslauf geschaltet werden.
 2. Durch entfernen der Teile 1 und 2 läuft der Motor unkontrolliert links oder rechts herum an.
- In beiden Fällen kann der Motor durch Drucktaster oder Fernschalter betätigt werden.

Direction of rotation of motor

1. By means of part 1 (switch) the direction of rotation can be fixed.
 2. By removing parts 1 and 2 the motor will rotate uncontrolled.
- In both instance, the motor can be operated by means of a push-button panel or by remote-control.

Sens de rotation du moteur

1. Le moteur peut tourner vers la droite ou vers la gauche à l'aide du contact, pièce 1.
 2. En écartant les pièces 1 et 2 le moteur tourne indifféremment à droite ou à gauche sans contrôle.
- Dans les deux cas le moteur peut être commandé par un interrupteur ou par une commande à distance.

Draairichting van de motor

1. De motor kan met de schakelaar (deel 1) op links of rechts draaiend worden ingesteld.
 2. Door verwijdering van de delen 1 en 2 draait de motor as ongecontroleerd naar links of rechts.
- In beide gevallen kan de motor met en drukknop schakelaar of relais worden ingeschakeld.

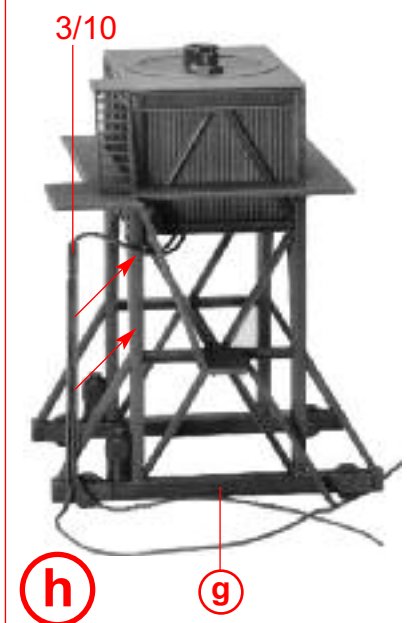
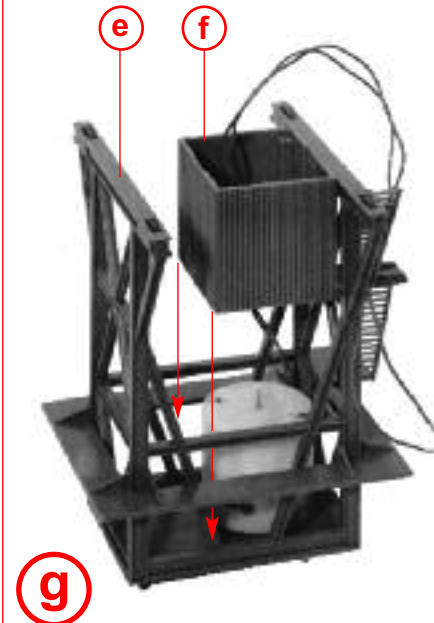
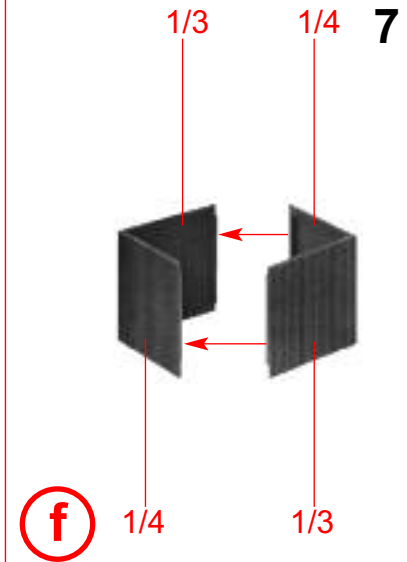
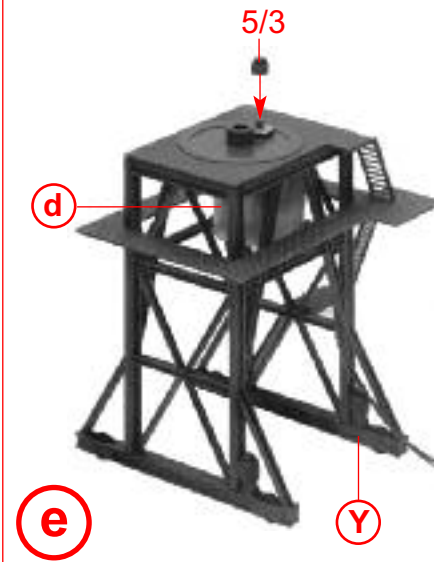

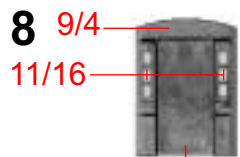

i

11/12

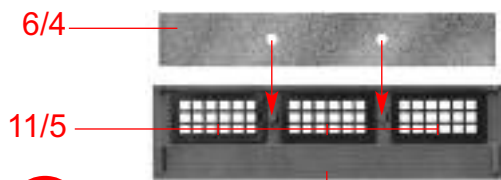

j 2 x

9/3

k



8/2

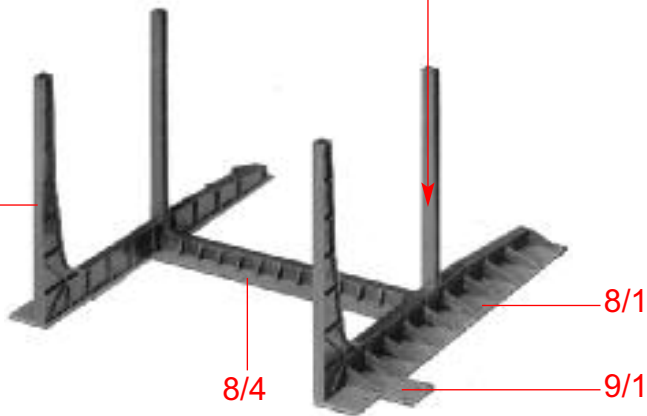

l

8/4

8/1

9/1

8/3

l

m

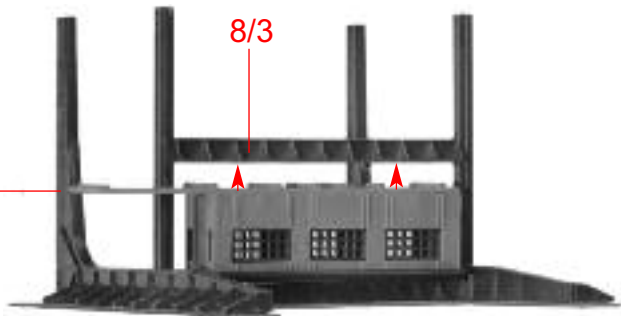

k

j

9/5

n

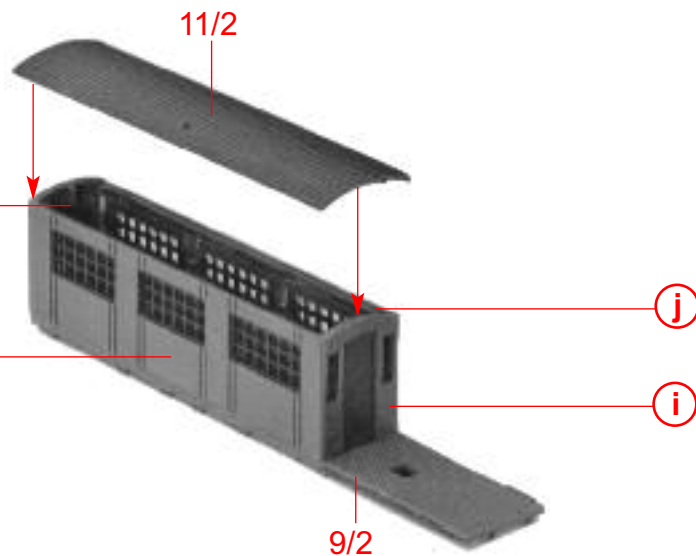

11/2

j

i

9/2

11/6

11/8

9/10

9/9

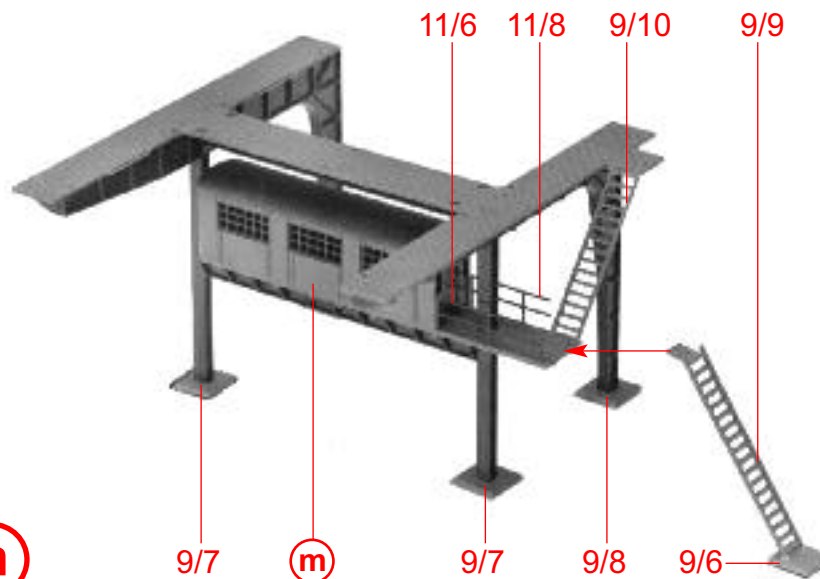

9/7

m

9/7

9/8

9/6

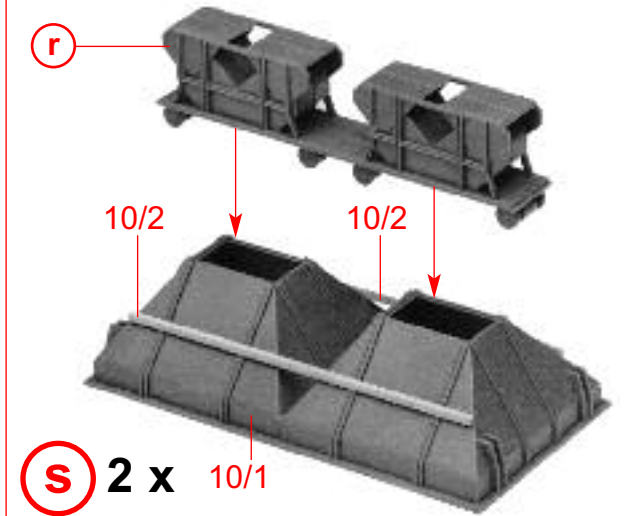
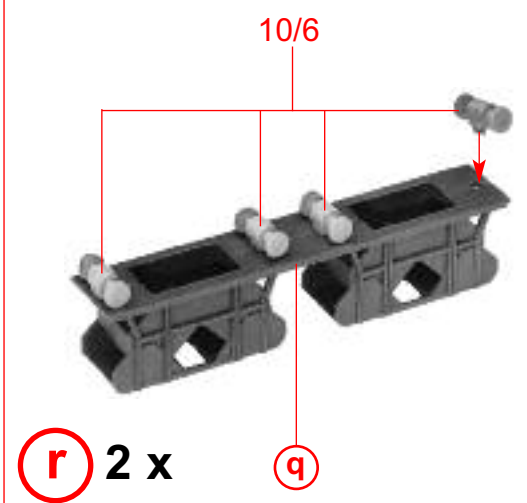
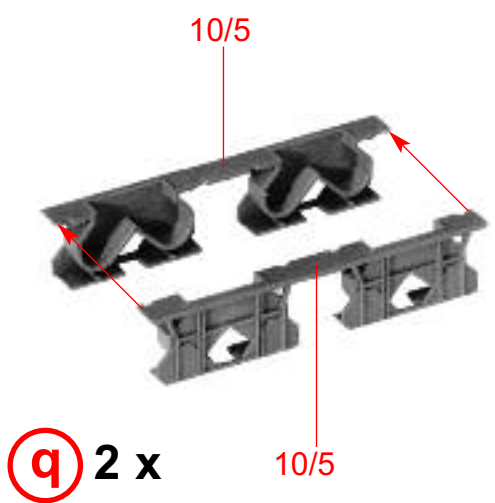
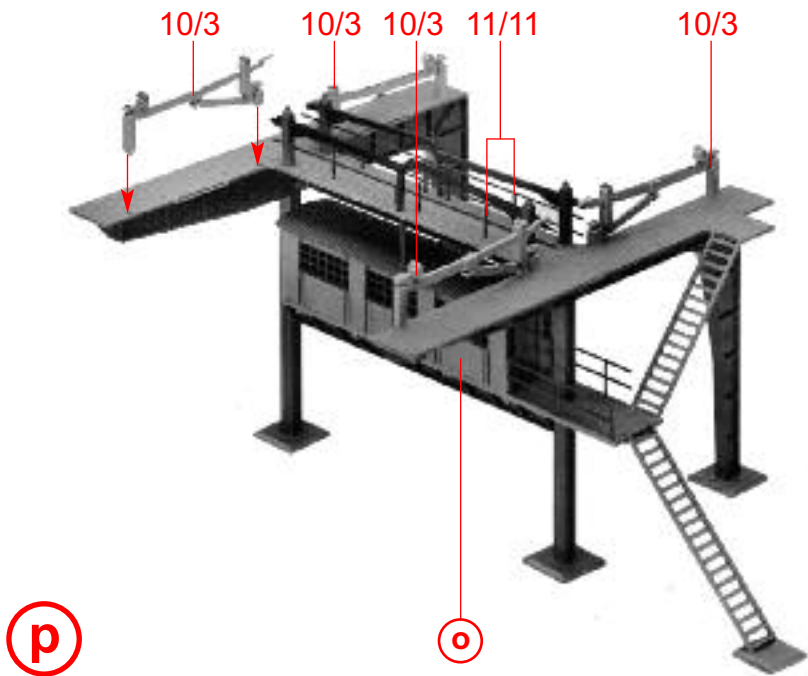
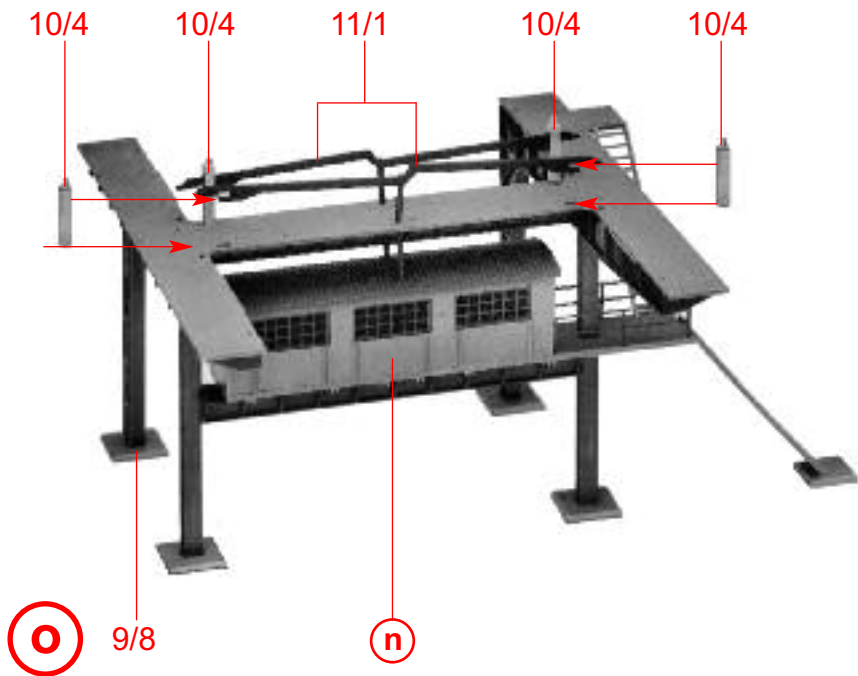

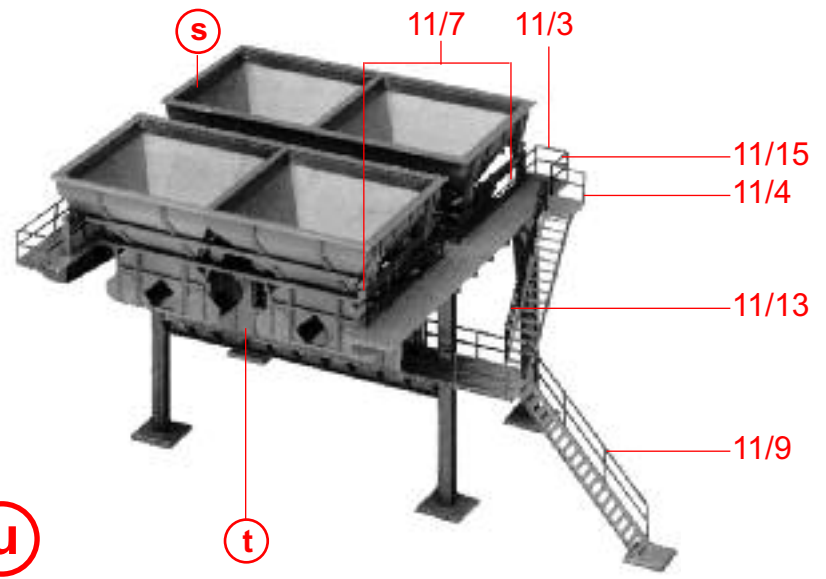
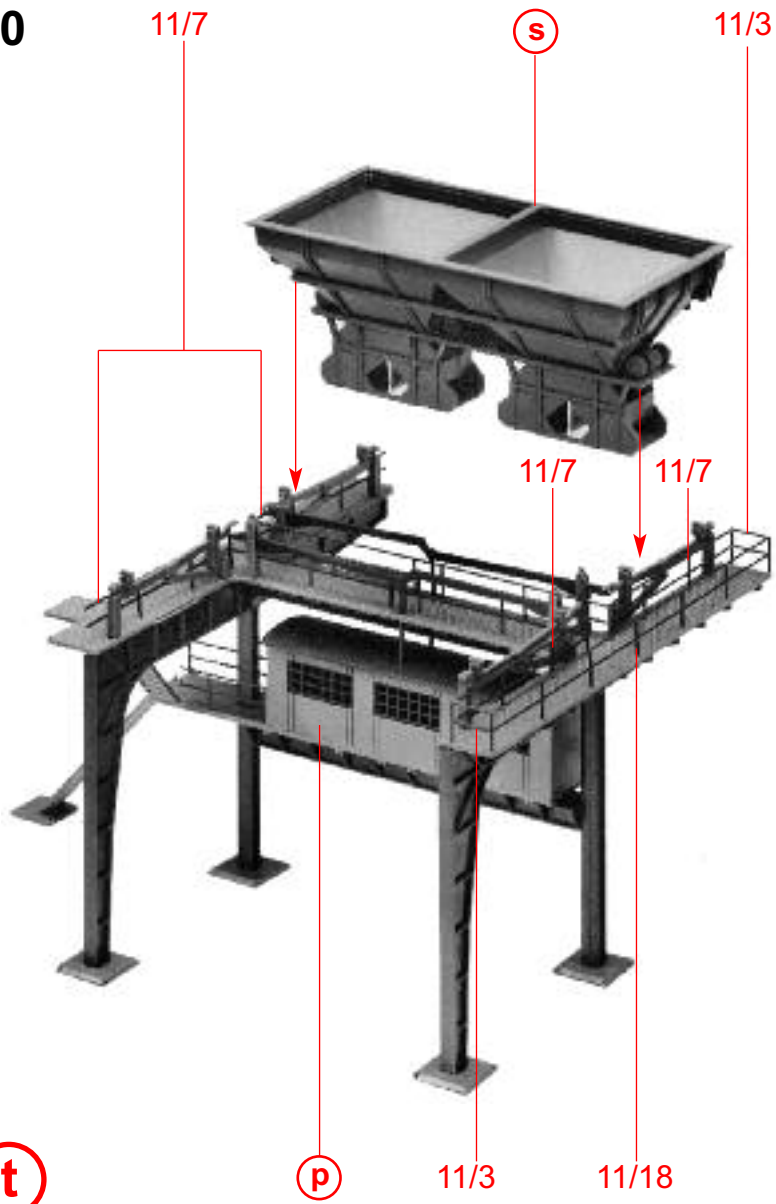
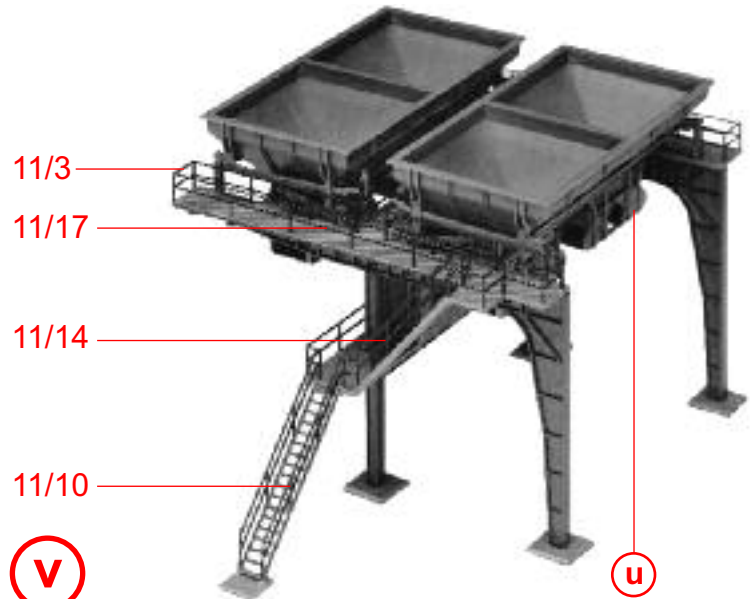
10**u****v****u**

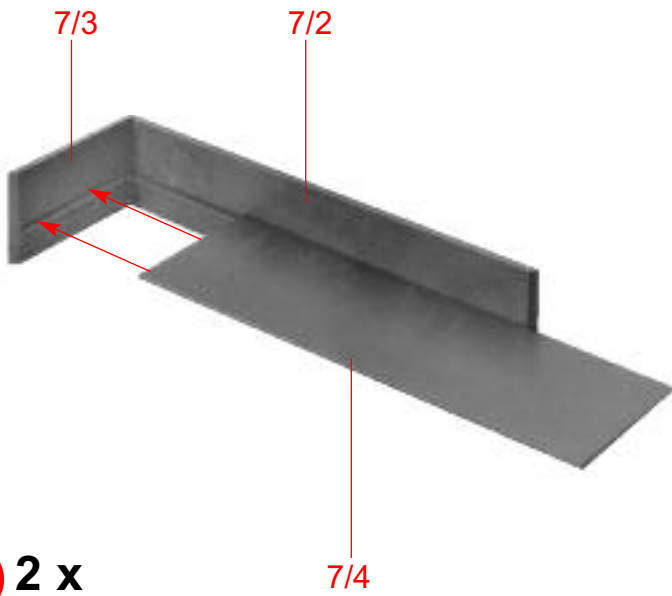

W 2 x

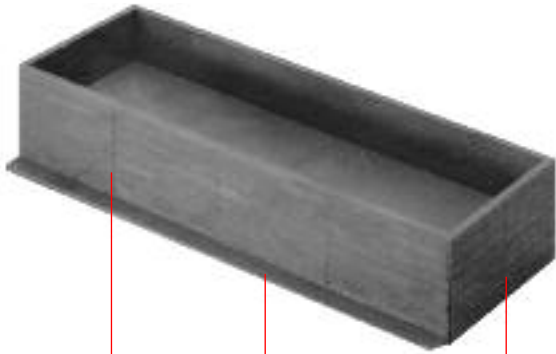

X 2 x

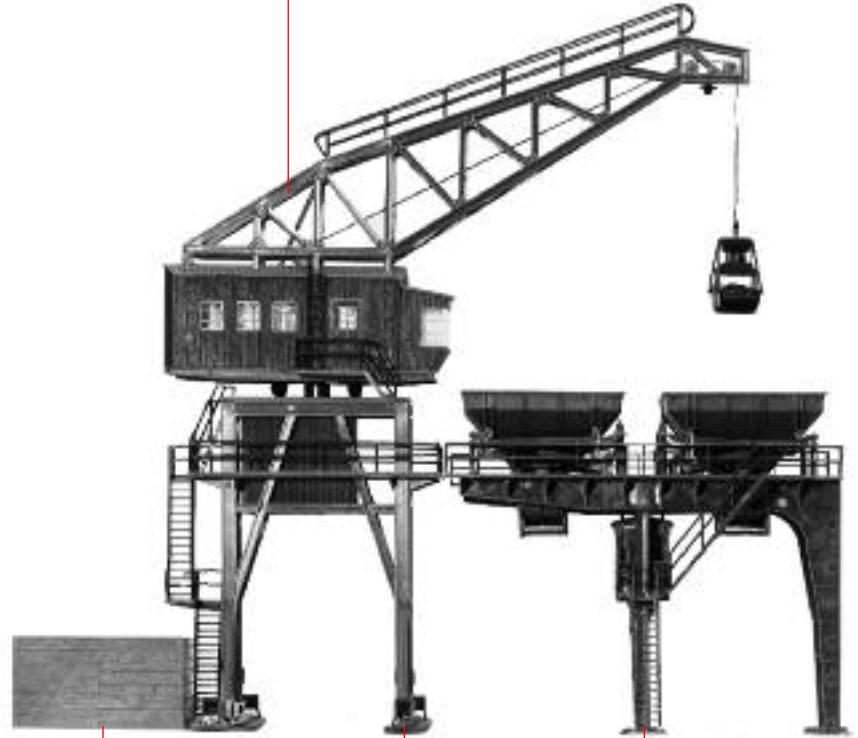

Y **X**

C

V

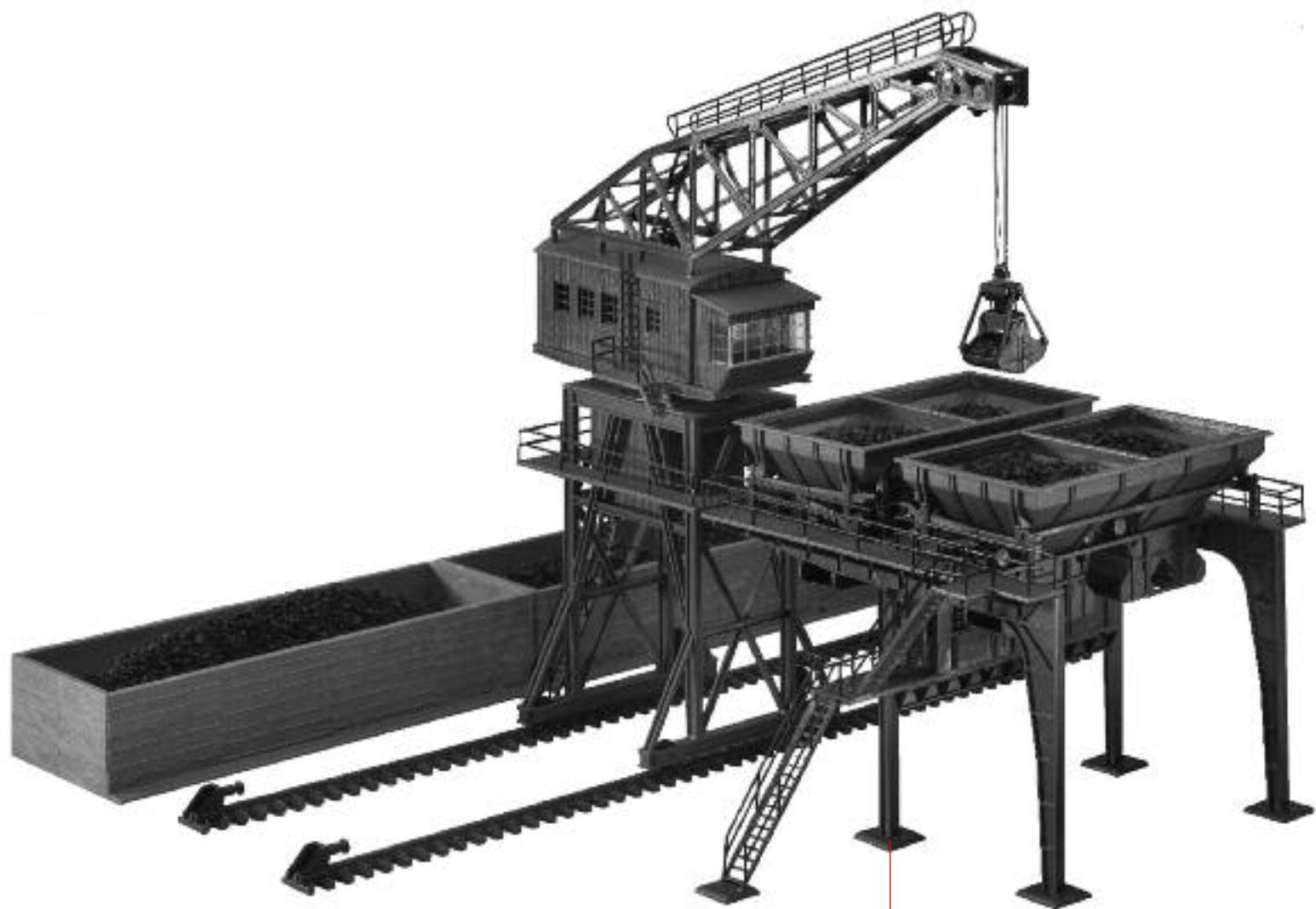

z

y