

# INSTRUCTION BOOK

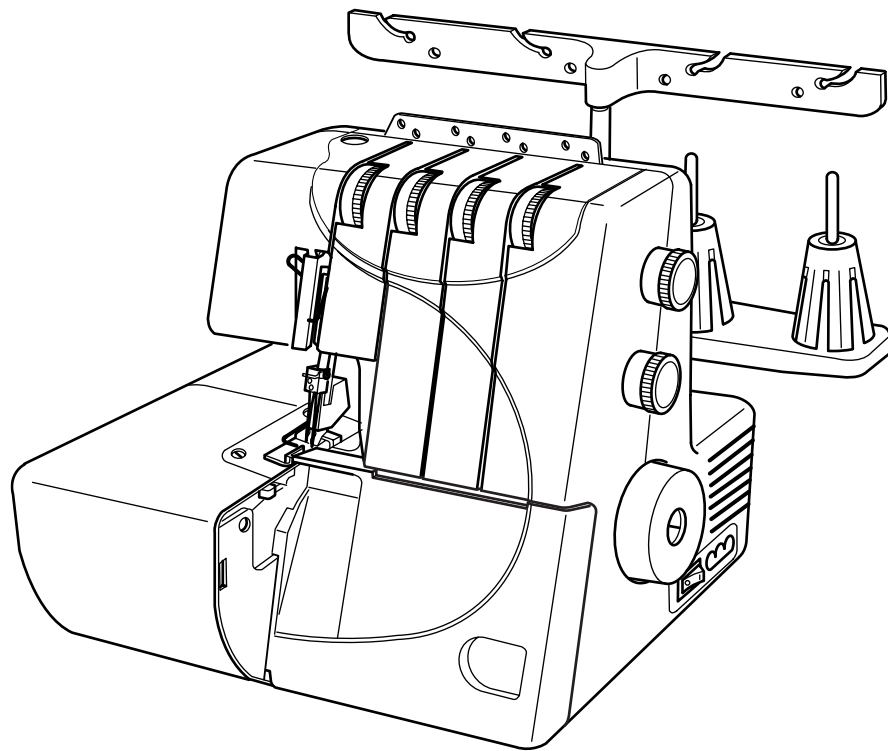

# TABLE OF CONTENTS

## PREPARATION

Names of Parts .....	8
Standard Accessories .....	8
Connecting the Machine to the Power Supply .....	10
Controlling Sewing Speed .....	10
For Your Safety .....	10
How to Turn the Handwheel .....	12
Opening and Closing the Side Cover .....	12
Opening and Closing the Looper Cover .....	12
The Position of Thread Guide Bar .....	14
Attaching the Spool Holder Cap and Net .....	14
Changing Needle .....	16
Raising or Lowering the Presser Foot .....	16
Removing the Presser Foot .....	18
Attaching the Presser Foot .....	18
Adjustment of Foot Pressure .....	18
Adjustment of Stitch Length .....	20
Adjustment of Differential Feed Ratio .....	20
To Deactivate the Upper Knife .....	22
To Activate the Upper Knife .....	22
Adjustment of Cutting Width .....	24
Adjustment of Needle Plate Setting Knob .....	26
Threading the Machine .....	28~46
• Threading the Lower Looper .....	30
• Threading the Upper Looper .....	36
• Threading the Needle on the Right .....	40
• Threading the Needle on the Left .....	44

## TEST STITCHING

Starting Sewing .....	48
Finishing Sewing .....	48
Sewing Continuously .....	48
How to use Guide Lines .....	48
Securing Ends .....	50
Thread Tension (4 threads) .....	52
Threading the Machine (3 threads) .....	56
Thread Tension (3 threads) .....	58
Thread and Needle Chart .....	60

## ROLLED HEMMING, PICOT EDGING AND NARROW HEMMING

Machine Setting and Thread, Fabric and Range of the Tension Dial .....	62
Thread Tension .....	66
For Better Results .....	68

## DECORATIVE OVEREDGING

Thread and Fabric .....	70
Machine Setting .....	70

## GATHERING

Thread and Fabric .....	70
Machine Setting .....	70

## PIN TUCKING

Thread and Fabric .....	72
Machine Setting .....	72
Sewing .....	72

## CARE OF YOUR MACHINE

Replacing the Upper Knife .....	74
Cleaning Upper Knife Area .....	74
Replacing the Light Bulb .....	76
Cleaning the Feed Dog .....	76
Oiling the Machine .....	78
Carrying the Machine .....	78
Troubleshooting .....	80

## OPTIONAL PARTS .....

## PREPARATION

### Names of Parts

- ① Left needle thread tension dial
- ② Right needle thread tension dial
- ③ Upper looper thread tension dial
- ④ Lower looper thread tension dial
- ⑤ Side cover
- ⑥ Looper cover
- ⑦ Handwheel
- ⑧ Power switch
- ⑨ Machine socket
- ⑩ Differential feed dial
- ⑪ Stitch length dial
- ⑫ Spool stand
- ⑬ Spool holder
- ⑭ Spool pin
- ⑮ Thread guide bar
- ⑯ Thread guide
- ⑰ Pressure adjusting screw
- ⑱ Presser foot
- ⑲ Needle plate setting knob
- ⑳ Thread cutter
- ㉑ Presser foot lifter
- ㉒ Needle plate
- ㉓ Upper knife release knob
- ㉔ Cutting width adjusting dial
- ㉕ Upper looper
- ㉖ Lower looper
- ㉗ Upper knife
- ㉘ Lower knife

### Standard Accessories

- ① Screwdrivers
- ② Tweezers
- ③ Set of needles

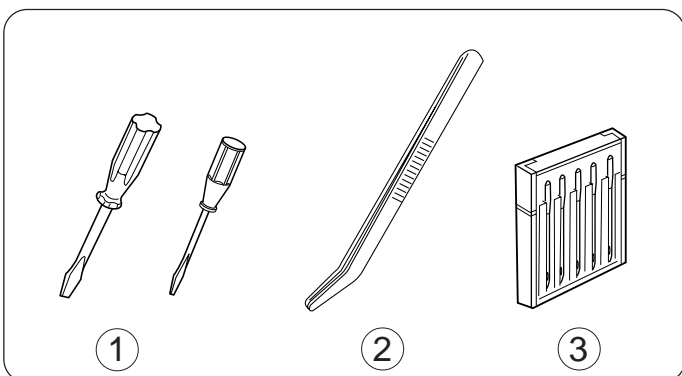
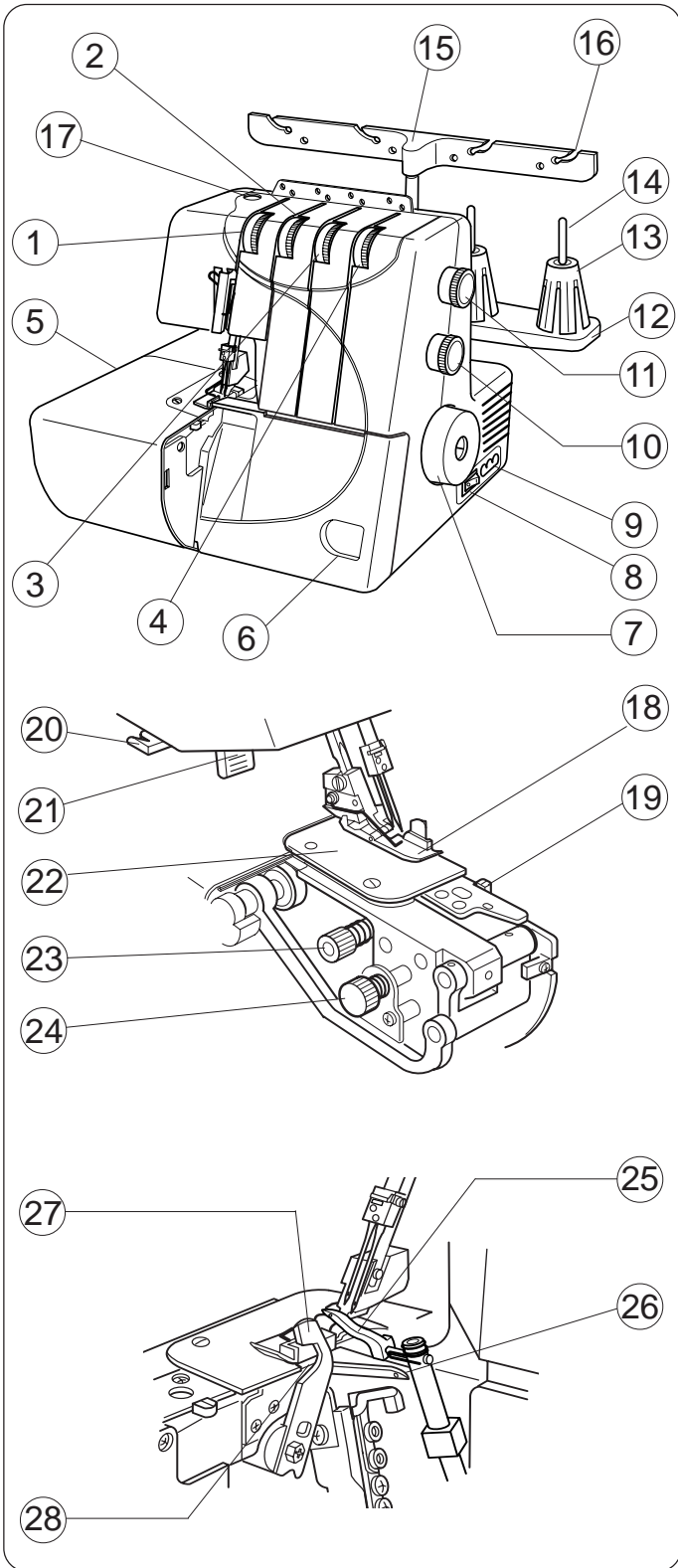

## Connecting the Machine to the Power Supply

Before connecting the machine to the power supply, make sure the voltage and frequency shown on the machine conform to your electrical power.

1. Turn off the power switch, and connect the machine plug to the machine socket.
2. Connect the power supply plug to your power supply.
3. Turn on the power switch.

- ① Power switch
- ② Machine plug
- ③ Machine socket
- ④ Power supply plug
- ⑤ Power supply
- ⑥ Speed controller

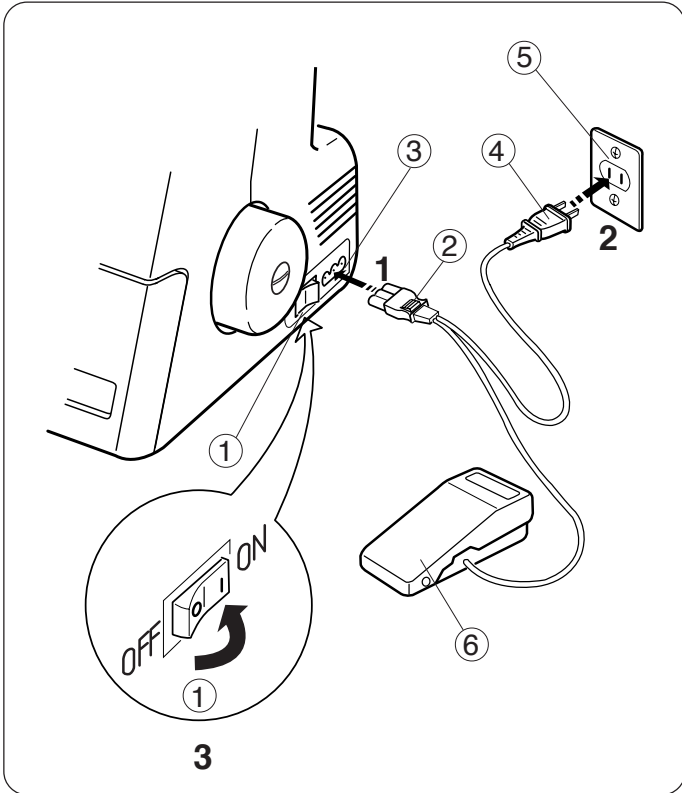

## Controlling Sewing Speed

Sewing speed can be varied by the speed controller. The harder you press on the controller, the faster the machine runs.

Step on the speed controller with the presser foot lifter up, and practice controlling the speed.

- ① Speed controller

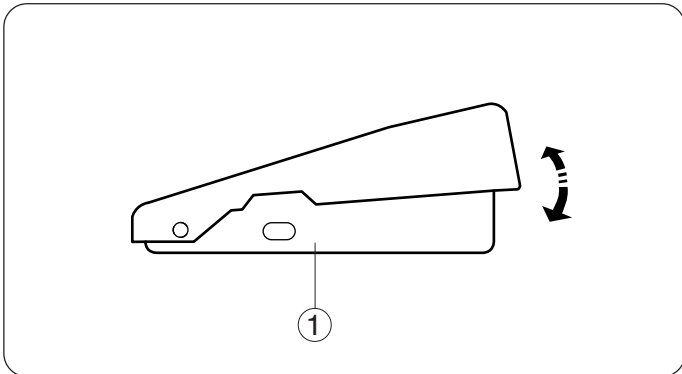

## Operating Instructions

(for U.S.A. and Canada only):

The symbol "O" of a switch indicates the "off" position of the switch.

For an appliance with a polarized plug (one blade wider than the other):

To reduce the risk of electrical shock, this plug is intended to fit in a polarized outlet only one way.

If it does not fit fully in the outlet, reverse the plug.

If it still does not fit, contact a qualified electrician to install the proper outlet. Do not modify the plug in any way.

The foot controller Model YC-482J or YC-482J-EC is used with this sewing machine

## For Your Safety:

- \* While in operation, always keep your eye on the sewing area, and do not touch any moving parts such as the thread take-up lever, loopers, handwheel, needle or knives.
- \* Always disconnect the machine from the power supply:
  - when leaving the machine unattended.
  - when attaching or removing parts.
  - when threading or cleaning the machine.
- \* Do not place anything on the foot control, otherwise the machine will start inadvertently.

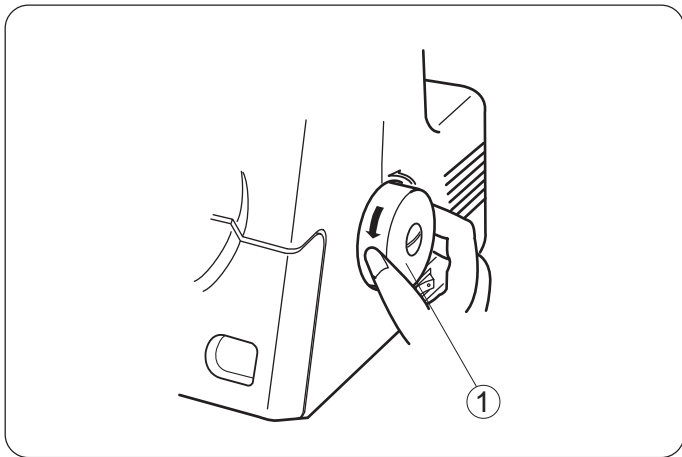

### How to Turn the Handwheel

Always turn the handwheel toward you (Counter-clockwise).

- ① Handwheel

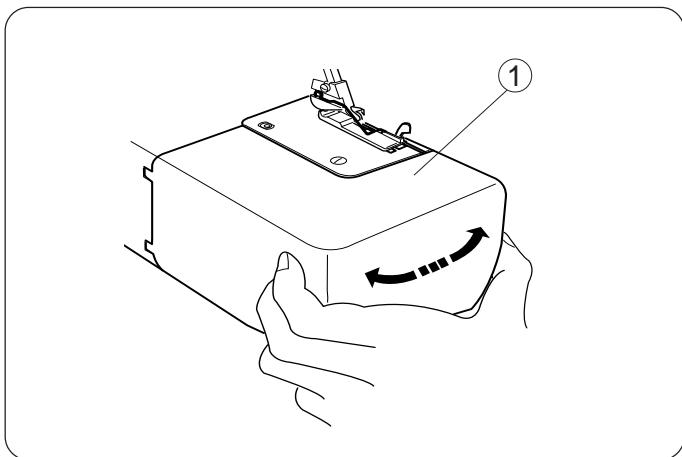

### Opening and Closing the Side Cover

To open:

Push the side cover to the left.

To close:

Push the side cover to the right.

- ① Side cover

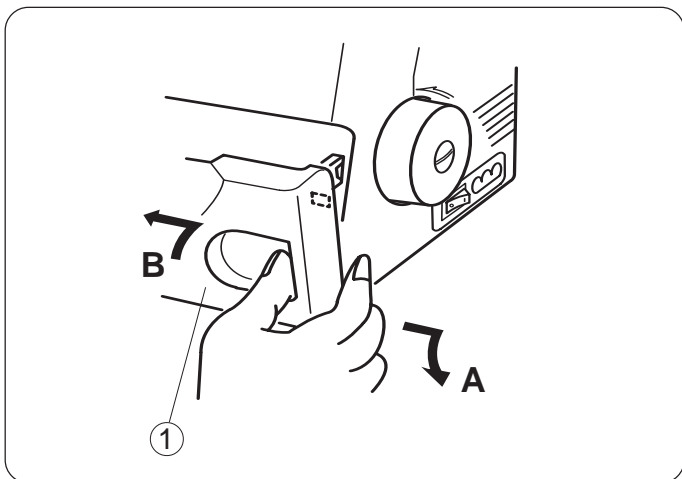

### Opening and Closing the Looper Cover

To open: **A**

While pushing with the thumb to the right as far as it will go, pull the looper cover toward you.

To close: **B**

Lift the looper cover and push it against the machine. The looper cover snaps into its position automatically.

- ① Looper cover

### NOTE:

Always close both side cover and looper cover when the machine is in use.

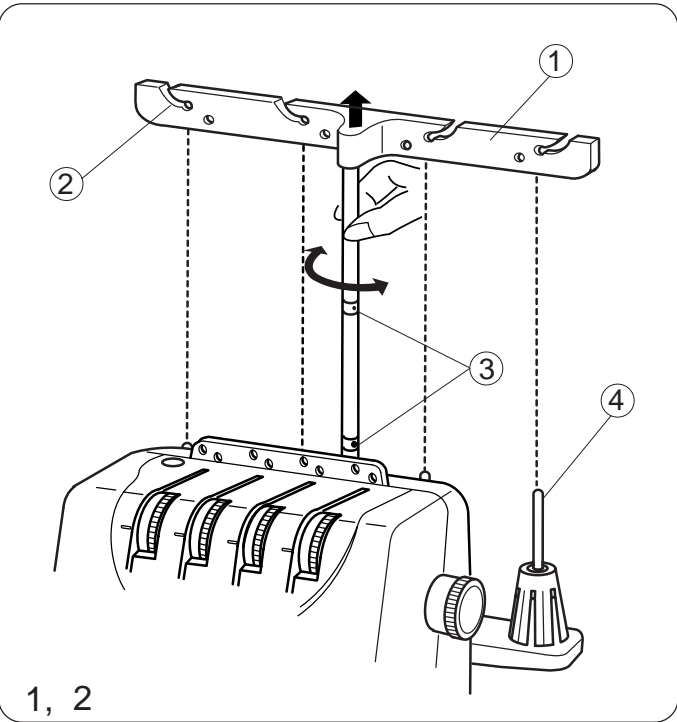

### The Position of Thread Guide Bar

1. Pull the thread guide bar up as far as it will go.
2. Turn the thread guide bar so that the thread guides are right above the spool pins.

- ① Thread guide bar
- ② Thread guide
- ③ Stoppers
- ④ Spool pin

\* Make sure to lock the thread guide of guide pole in the correct position with the two stoppers.

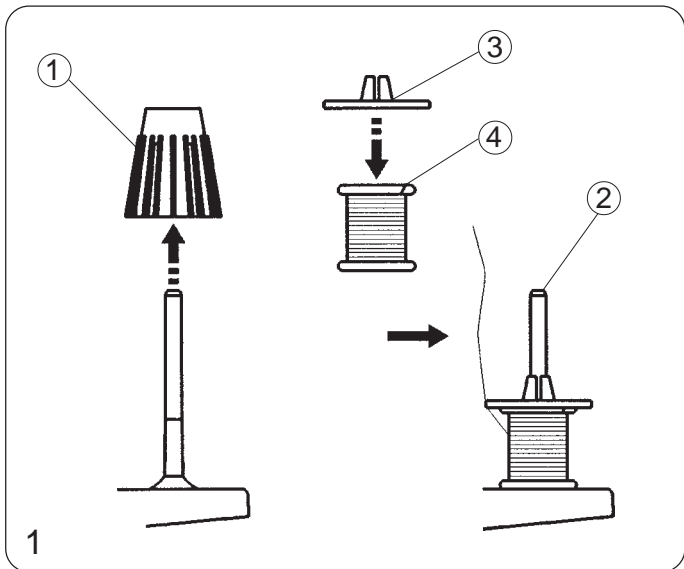

### Attaching the Spool Holder Cap and Net

1. When you use a small thread spool, pull out the spool holder from the spool pin. Then place the spool with its slit side up, and put the spool holder cap on top of it.

- ① Spool holder
- ② Spool pin
- ③ Spool holder cap
- ④ Slit

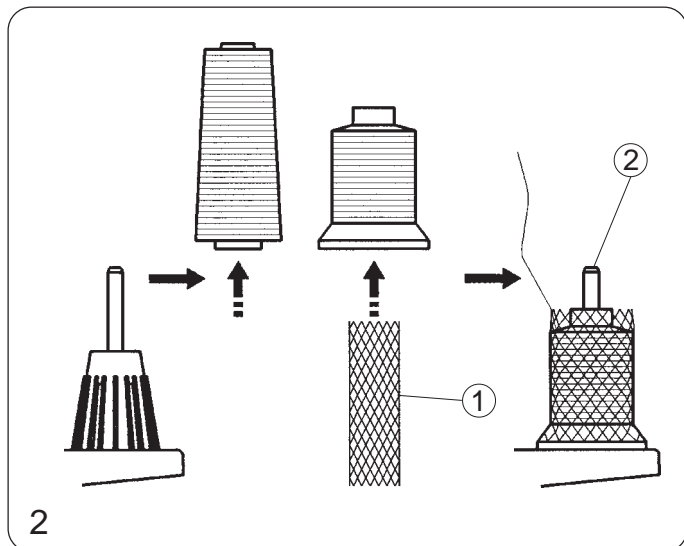

2. If the thread slips down from the spool during threading and/or sewing, put a net on the spool as illustrated to prevent jamming.

\* The spool holder cap and net are optional accessories.

- ① Net
- ② Spool pin

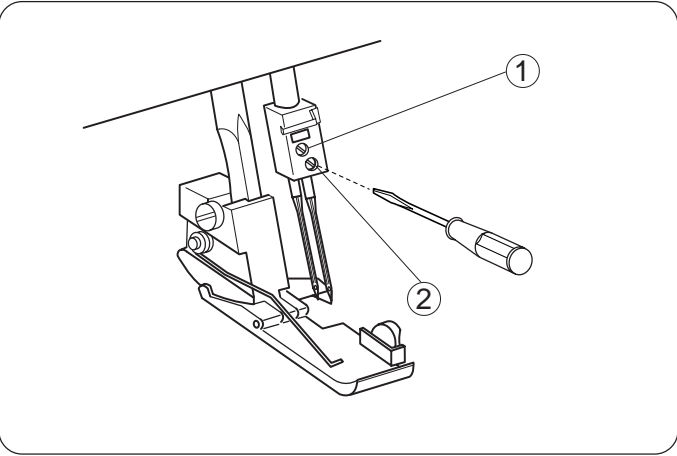

### Changing Needle

Turn off the power switch and unplug the machine.  
Raise the needle to its highest position.

Then loosen the left or right needle clamp screw for the needle you are going to remove.

- ① Needle clamp screw on the left
- ② Needle clamp screw on the right

\* Use HA-1SP #14 Needle or #11.

To attach the needle on the right :

Insert a new needle into the needle clamp with the flat side to the back until the top of the needle touches the stopper pin, then tighten the needle clamp screw on the right.

To attach the needle on the left :

Insert a new needle into the needle clamp with the flat side to the back until the top of the needle touches the edge of the needle bar, then tighten the needle clamp screw on the left.

\* When the needles are set correctly, the left needle is higher than the right one.

\* Use HA-1SP #14 Needle or #11.

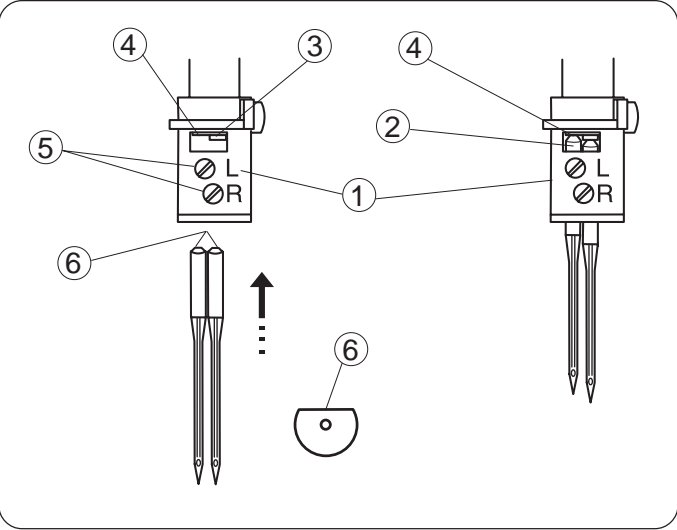

- ① Needle clamp
- ② Needle
- ③ Needle stopper pin
- ④ Edge of needle bar
- ⑤ Needle clamp screws
- ⑥ Flat side to the back

\* Do not use any needle which is bent or blunt.

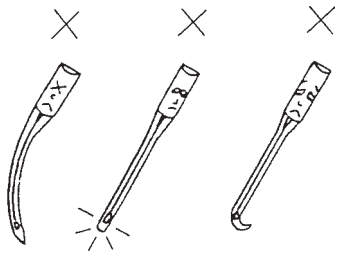

### Raising or Lowering the Presser Foot

By raising or lowering the presser foot lifter, the presser foot goes up or down.

\* While in operation, keep the presser foot lowered except when threading the machine or test running without threads.

Thread tension will be released when the presser foot lifter is raised.

- ① Presser foot
- ② Presser foot lifter

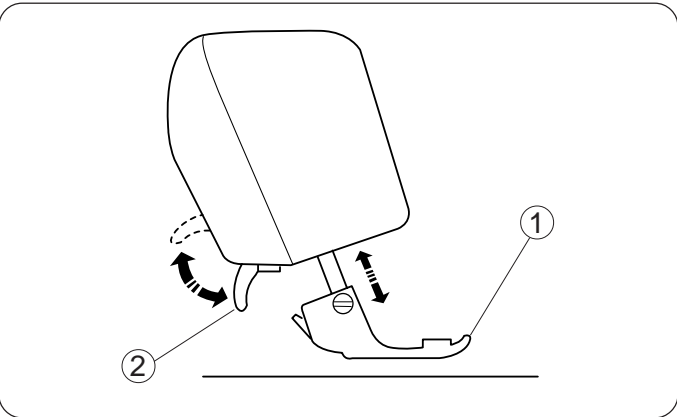

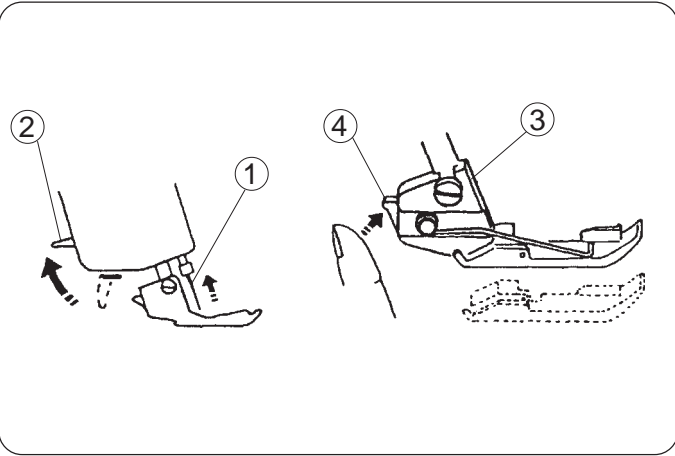

## Removing the Presser Foot

1. Turn off the power switch and unplug the machine.
2. Raise the needle and the presser foot.
3. Press the lever located on the back of the foot holder. The presser foot will drop off.

- ① Needle
- ② Presser foot lifter
- ③ Foot holder
- ④ Lever

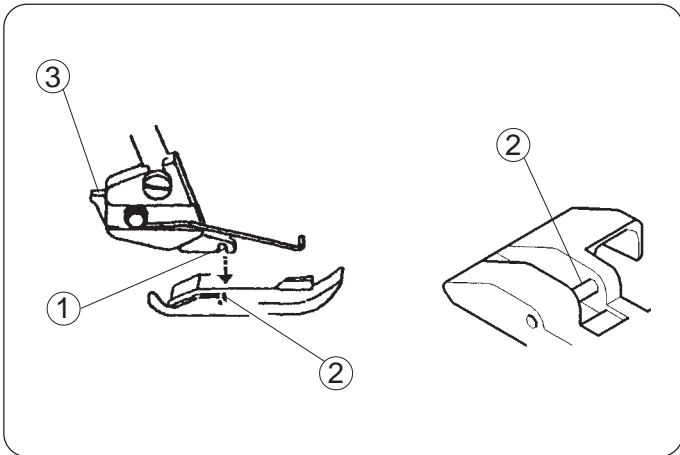

## Attaching the Presser Foot

1. Turn off the power switch and unplug the machine.
2. Place the presser foot so that the pin on the foot lies just under the groove of the foot holder.
3. Lower the foot holder to lock the foot into place.
4. Raise the presser foot lifter to check that the presser foot is secure.

- ① Groove
- ② Pin
- ③ Lever

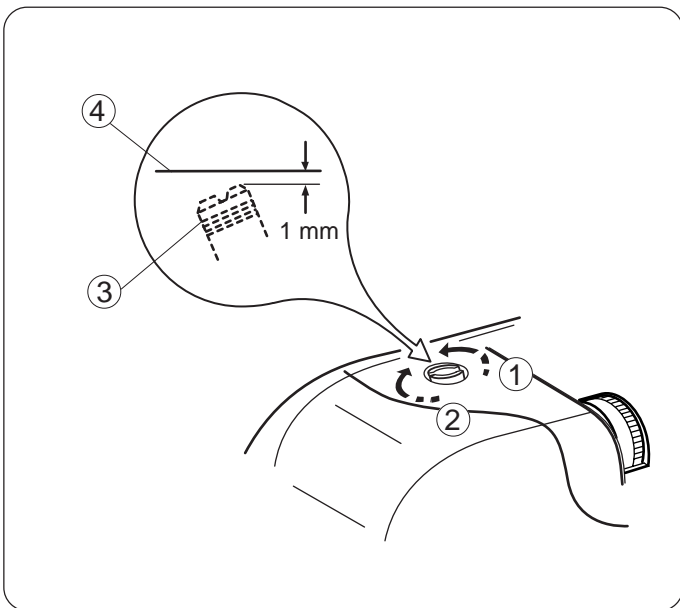

## Adjustment of Foot Pressure

It is not necessary to adjust the presser foot's pressure for normal sewing.

When you sew heavy or lightweight fabrics, turn the adjusting screw:

- clockwise for heavyweight fabric.
- counterclockwise for lightweight fabric.

\* For normal sewing, set the adjusting screw so that it sits 1mm below the top of the machine.

- ① To decrease
- ② To increase
- ③ Adjusting screw
- ④ Top of the machine



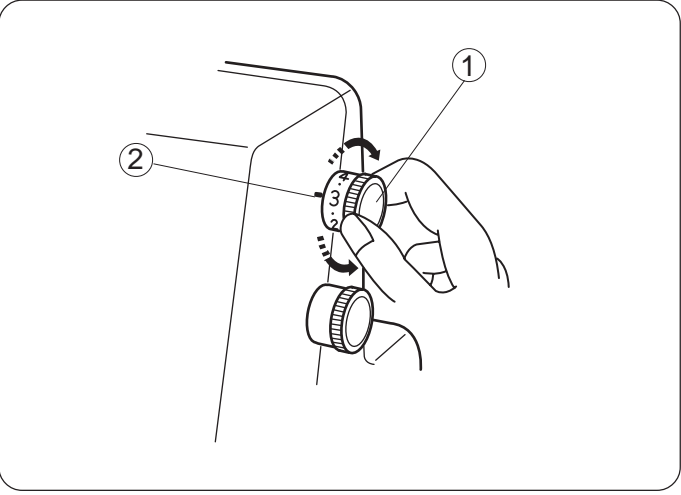

**Adjustment of Stitch Length**

To select stitch length, turn the dial.  
 The larger the number, the longer the stitch.  
 The stitch length can be adjusted from 1 to 4 mm.  
 Position “R” is for rolled and narrow hemmings.

- ① Stitch length dial
- ② Setting mark

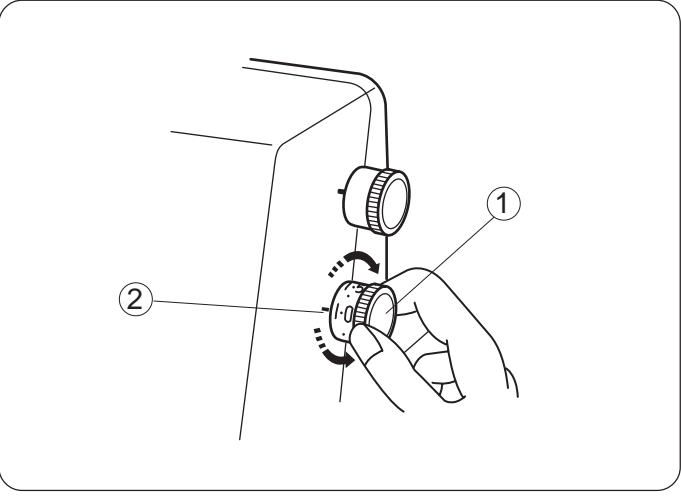

**Adjustment of Differential Feed Ratio**

The differential feed ratio can be altered by turning the dial.  
 The number on the dial indicates the ratio between the main and the sub feed motion.  
 1.0 indicates the neutral position.

- ① Differential feed dial
- ② Setting mark

**How to adjust**

- If the sewn fabric is stretched, turn the dial counterclockwise (toward 2.2).
- If the sewn fabric is gathered, turn the dial clockwise (toward 0.5).

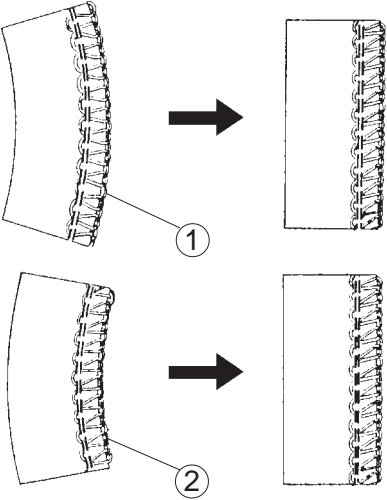

- ① Stretched
- ② Gathered

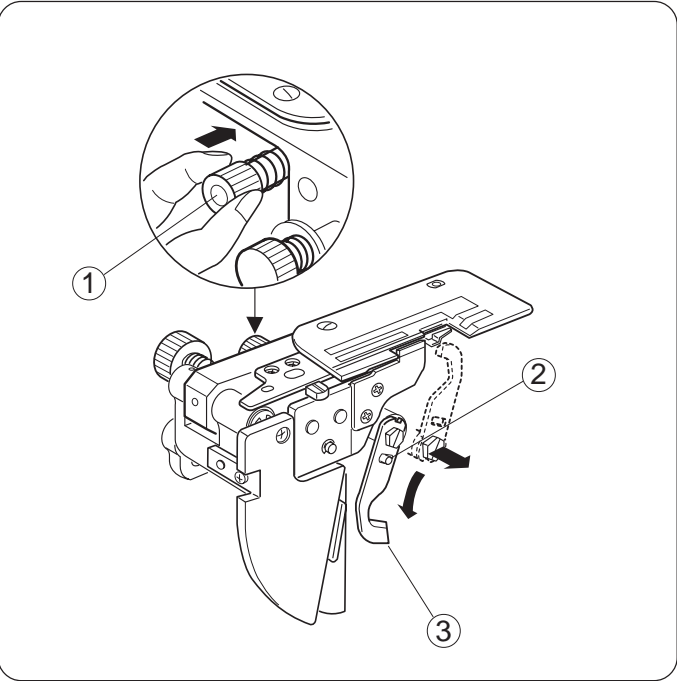

**To Deactivate the Upper Knife**

1. Turn off the power switch and unplug the machine.
2. Open both the looper cover and side cover.
3. Turn the upper knife release knob toward you while pushing it to the right, then guide the hole on the upper knife to the pin to lock the upper knife in the down position.
4. Close the looper cover and side cover.

- ① Upper knife release knob
- ② Stopper pin
- ③ Upper Knife

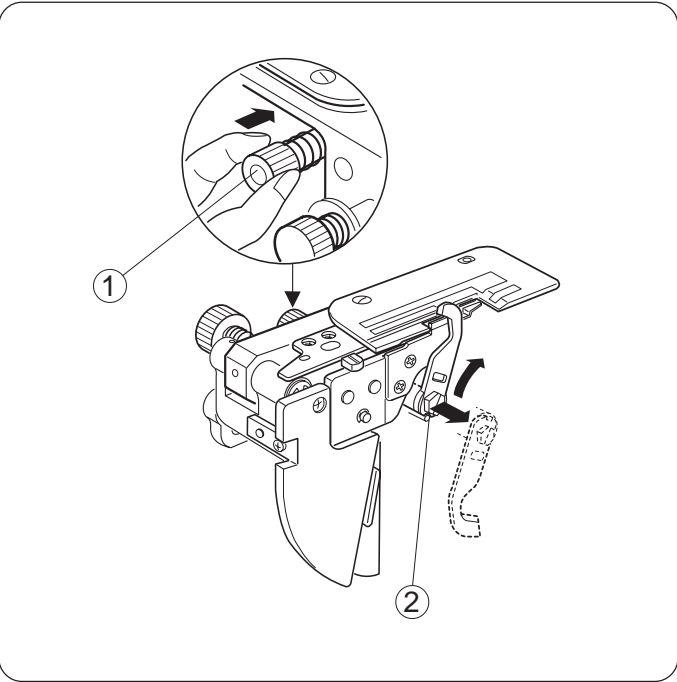

**To Activate the Upper Knife**

1. Turn off the power switch and unplug the machine.
2. Open both the looper cover and side cover.
3. Turn the upper knife release knob away from you while pushing it to the right, then guide the groove on the upper knife to the pin to lock the upper knife in the up position.
4. Close the looper cover and side cover.

- ① Upper knife release knob
- ② Stopper pin

## Adjustment of Cutting Width

When cutting width is too narrow or too wide against seam width, adjust it as follows.

1. Turn off the power switch and unplug the machine.
2. Open the looper cover and side cover.
3. Set the upper knife to down position

4. Turn the cutting width adjusting dial to get desired position of lower knife.

- ① Cutting width adjusting dial
- ② Lower knife
- ③ Standard setting

\* The cutting width of this model can be adjusted approximately 3.0 to 5.0 mm from the right needle position depending upon your sewing needs or the fabric being used.  
(The cutting width should be adjusted to get the same results as in drawing ④.)

When cutting width is too narrow.

Turn cutting width adjusting dial clockwise (A).  
Lower knife will move to right.

When cutting width is too wide.

Turn the cutting width adjusting dial counterclockwise (B).  
Lower knife will move to left.

5. Set the upper knife to up position.

6. Close the looper cover and side cover.

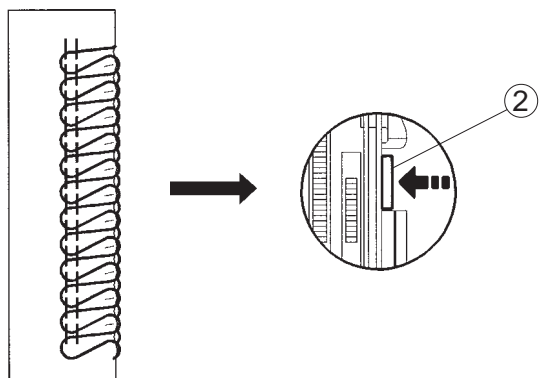
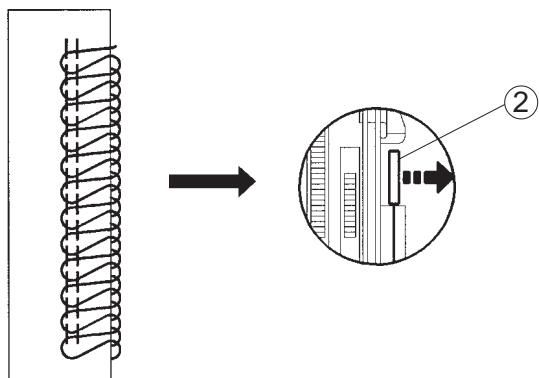
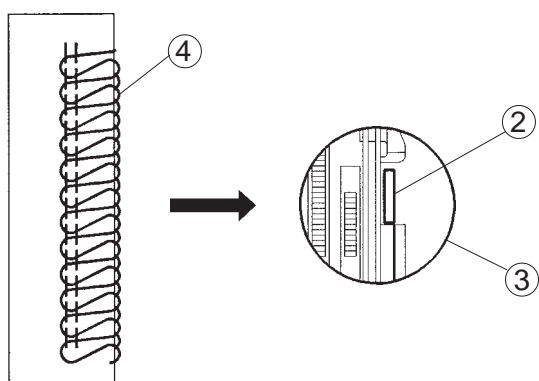
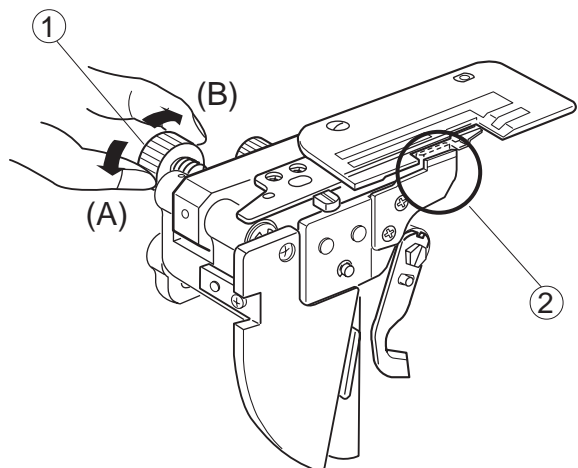

## Adjustment of Needle Plate Setting Knob (Changing to Standard Serging or Rolled Hemming)

1. Turn off the power switch and unplug the machine.
2. Open the looper cover and side cover.
3. Deactivate the upper knife.
4. Push the cutting width adjusting dial to the right as far as it will go, then, move the needle plate setting knob to the guide line of S (for Standard Serging) or R (for Rolled Hemming). Release the cutting width adjusting dial to the left gently.
5. Set the upper knife to up position.
6. Close the looper cover and side cover.

- ① Chaining finger
- ② Guide line
- ③ Cutting width adjusting dial
- ④ Upper knife
- ⑤ Needle plate setting knob

(A)

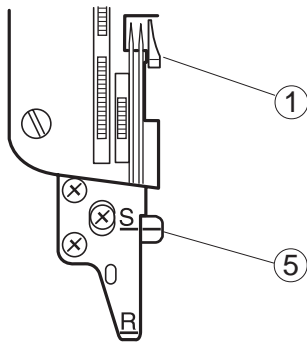

(A) Standard Serging

- \* The chaining finger is located beside the needle plate as shown in diagram (A) for guiding the flat edge of the fabric for overlock sewing.

(B)

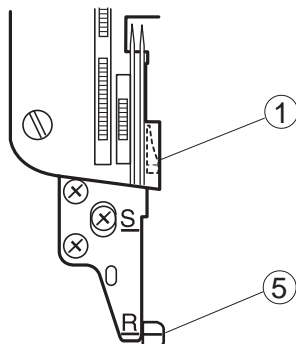

(B) Rolled Hemming

- \* Pull the needle plate setting knob from "S" to "R" position, so that the fabric edge will be rolled for hemming, picot edging and narrow hemming.

## Threading the Machine

The left illustration shows the completed threading conditions of four threads.

- ① Lower looper thread
- ② Upper looper thread
- ③ Right needle thread
- ④ Left needle thread
- ⑤ Thread guide
- ⑥ Thread guide plate
- ⑦ Threading chart

The machine is pre-threaded to make threading easier.

Tie the end of a new thread to one of the pre-set threads, and pull it to draw the new thread through the machine, following the steps below.

\* Turn off the power switch before threading the machine.

1. Pull the threads from the spools and draw them through the thread guides, then tie the thread ends together.
2. Raise the presser foot, draw the threads until the knots are coming out from under the back of the presser foot.
3. However, stop drawing the needle threads when the knots reach just before the needle eye. Cut the knots and thread the needle eye.
4. Before starting sewing, clear the needle threads from under the presser foot to make sure they are not caught below the needle plate.

(Draw the needle threads in the direction A)  
Then pull out the threads to the back approximately 10 cm (4") away from the presser foot.  
Lower the presser foot, and you are now ready to sew.

- ① Thread guide
- ② Needle
- ③ Needle thread
- ④ Presser foot
- ⑤ Needle plate

- For re-threading the machine easily, start from the lower looper, upper looper, right needle and left needle threads.  
Make sure to clear the needle threads out from below the needle plate and draw them to the back and under the presser foot about 10 cm (4").

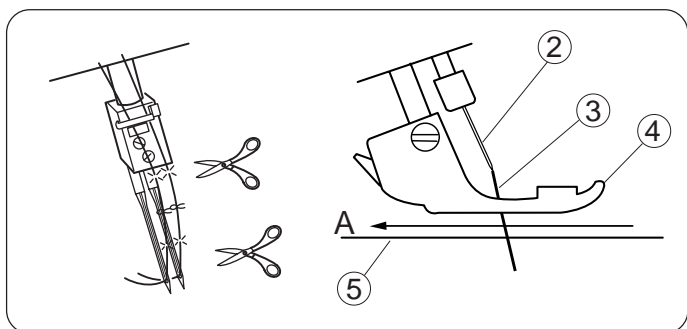
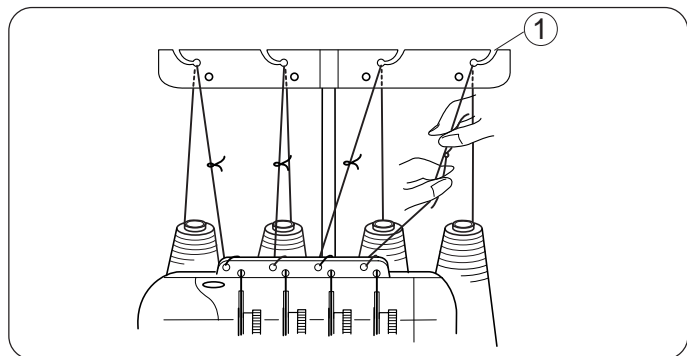
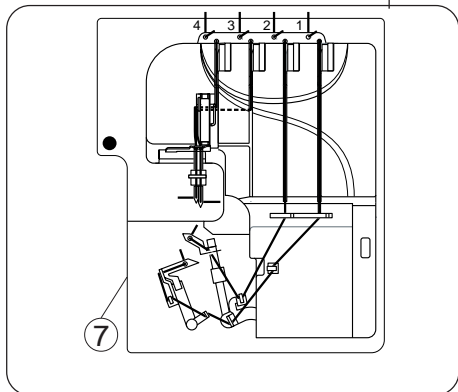
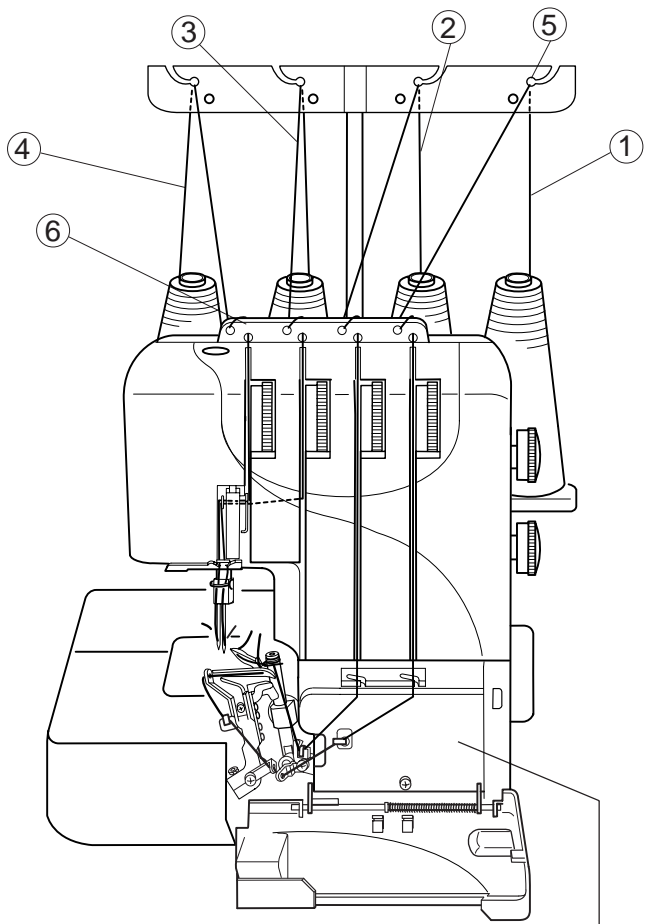

**• Threading the Lower Looper**

Open the looper cover and side cover.  
Place the spool of thread on the right side spool pin.

- \* The points to thread for lower looper are marked in green.
- \* A convenient threading chart is placed on the machine body inside the looper cover.

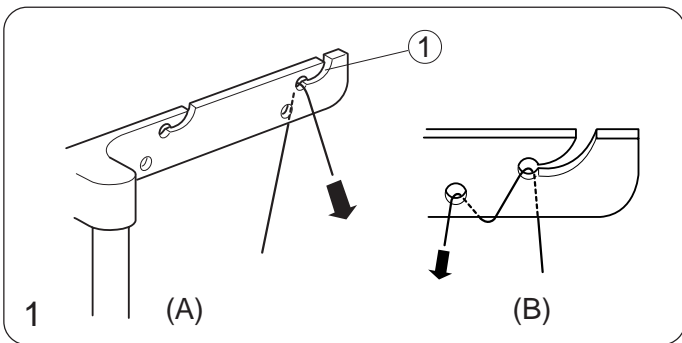
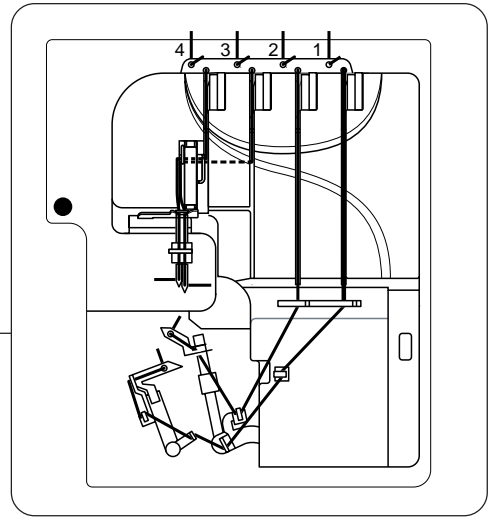
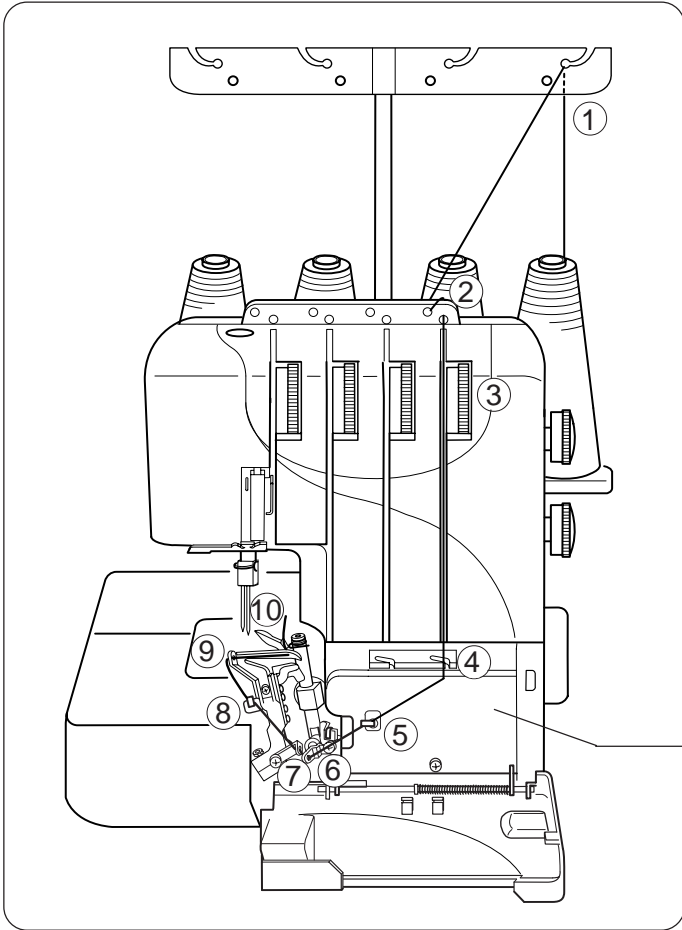

1. Draw the thread through the right side thread guide from back to front: (A)

- \* If the thread is coming out from the thread guide groove, pass the thread through the thread guide hole again as shown: (B)

① Thread guide

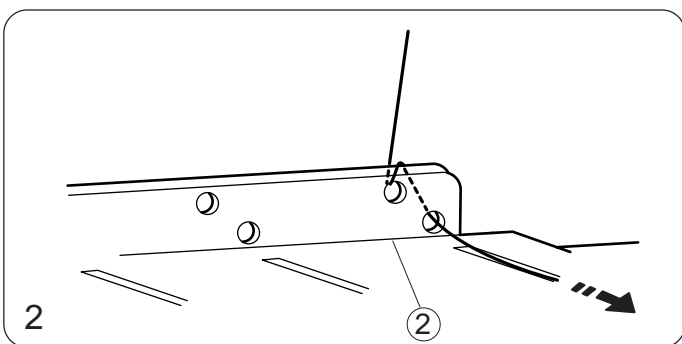

2. Pass the thread through the holes on the right side of the thread guide plate as illustrated.

② Thread guide plate

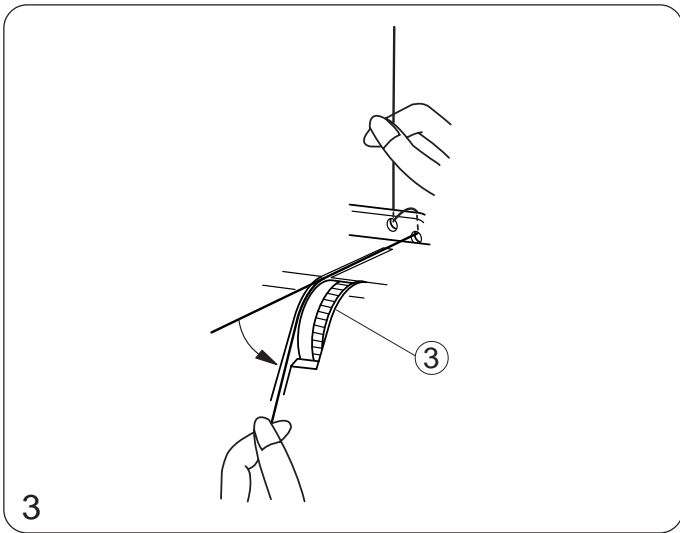

3. Hold the thread at both ends and tug gently to ensure the thread is correctly inserted between the tension discs. (If the presser foot lifter is raised, the thread easily inserts between the tension discs.)

③ Lower looper thread tension dial

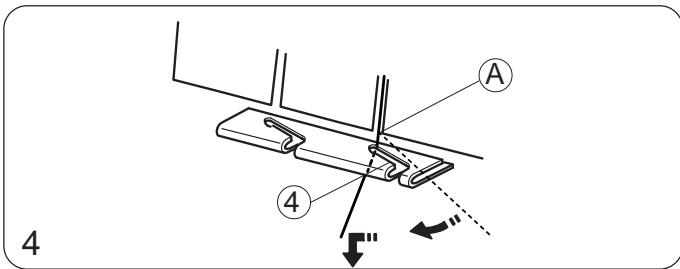

4. Hook the thread on the corner (A), and then pass the thread through the looper thread guide.

④ Looper thread guide

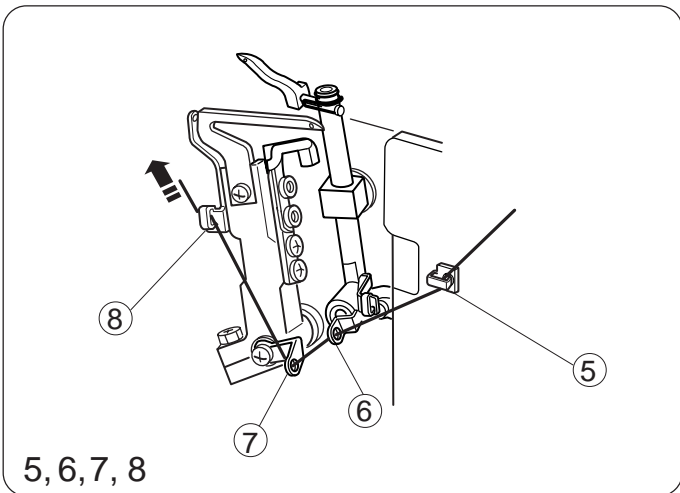

5. Pass the thread through lower looper thread guide (1).

6. Pass the thread through the looper thread take-up lever (lower).

7. Pass the thread through lower looper thread guide (2).

8. Pass the thread through lower looper thread guide (3).

⑤ Lower looper thread guide (1)

⑥ Looper thread take-up lever (lower)

⑦ Lower looper thread guide (2)

⑧ Lower looper thread guide (3)

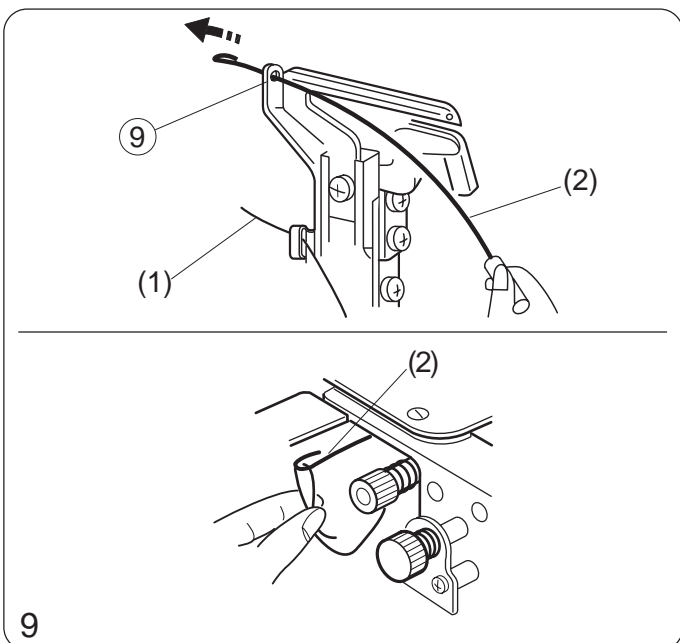

9. Turn the handwheel toward you until the lower looper comes to the right, and pass the threader through the hole on lower looper thread guide (4).

Hook the end of the thread on the threader.

\* Looper threader is optional.

\* If you don't have the looper threader, turn the handwheel towards you until the lower looper comes to its most left position. Thread lower looper thread guide (4) from the left side with a pair of tweezers. Then, turn the handwheel towards you to move the lower looper to the right position.

⑨ Lower looper thread guide (4)

(1) Lower looper thread

(2) Looper threader

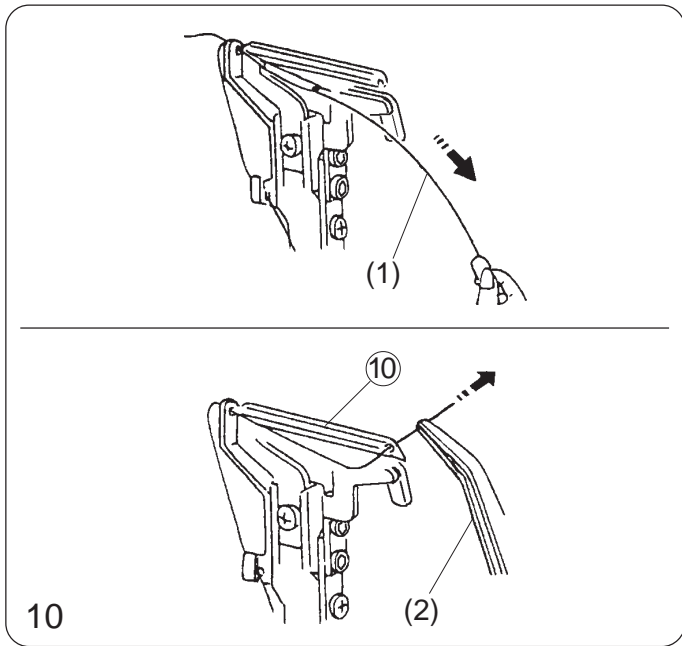

10. Pull the threader to pass the thread through the hole of lower looper thread guide (4).

Remove the thread from the threader, and draw the thread through the hole on the lower looper 10 cm (4") or more with a pair of tweezers.

\* For threading without the looper threader, draw the thread from the right side of lower looper thread guide (4) with a pair of tweezers.

\* And draw the thread through the hole on the lower looper 10 cm (4") or more with a pair of tweezers.

⑩ Lower looper

(1) Looper threader

(2) Tweezers

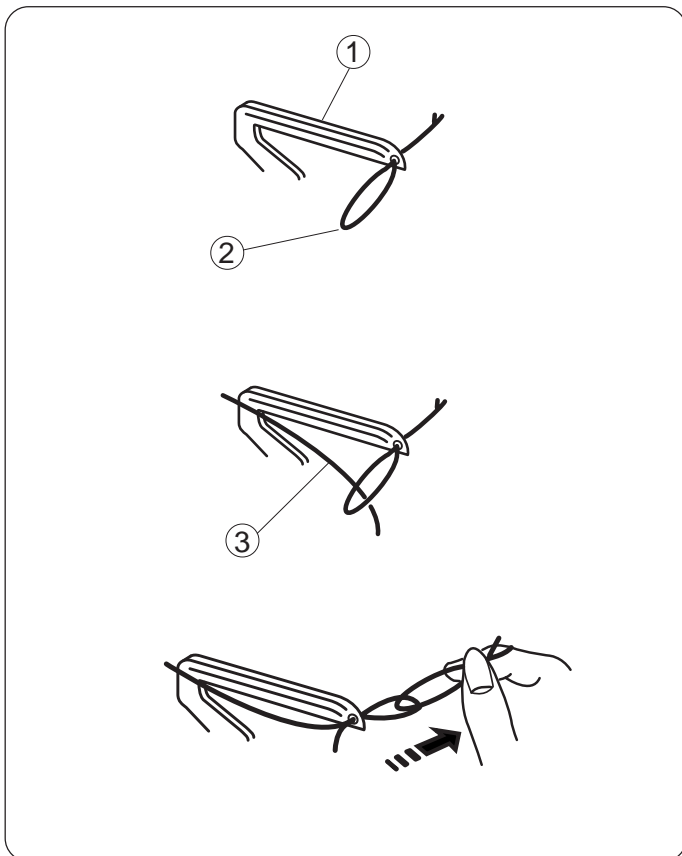

**NOTE:** How to thread woolly nylon/polyester thread.

\* The illustration at left shows one of the easiest ways to pass woolly nylon/polyester thread through the lower looper.

① Lower looper

② Ordinary thread

③ Woolly nylon/polyester thread



• **Threading the Upper Looper**

Place a spool of thread on the spool pin second from the right.

- \* The points to thread for upper looper are marked in red.
- \* A convenient threading chart is placed on the machine body inside the looper cover.

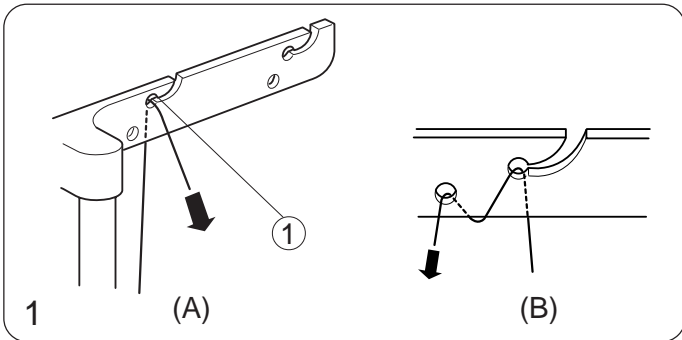
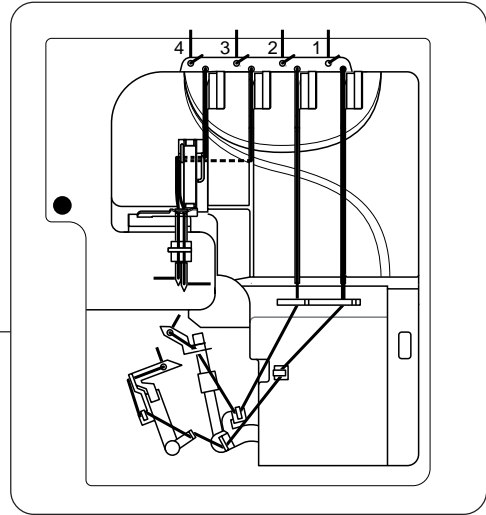
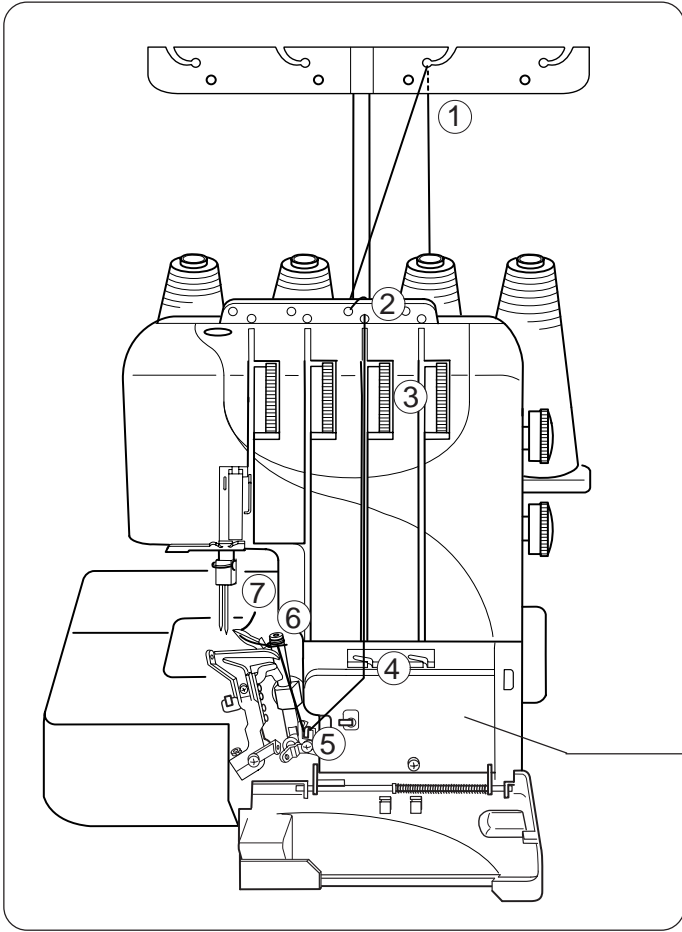

1. Draw the thread through the thread guide second from the right from back to front: (A)

- \* If the thread is coming out from the thread guide groove, pass the thread through the thread guide hole again as shown: (B)

① Thread guide

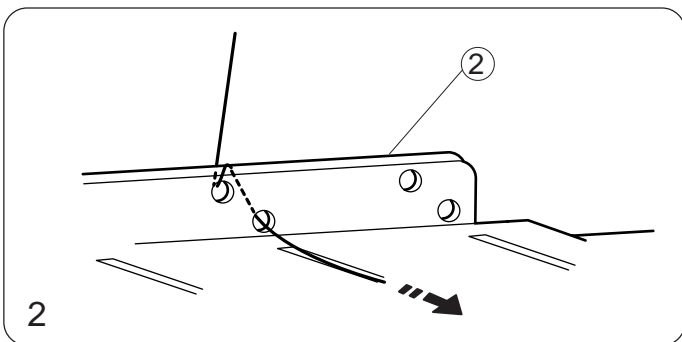

2. Pass the thread through the holes in the second row from the right of thread guide plate as illustrated.

② Thread guide plate

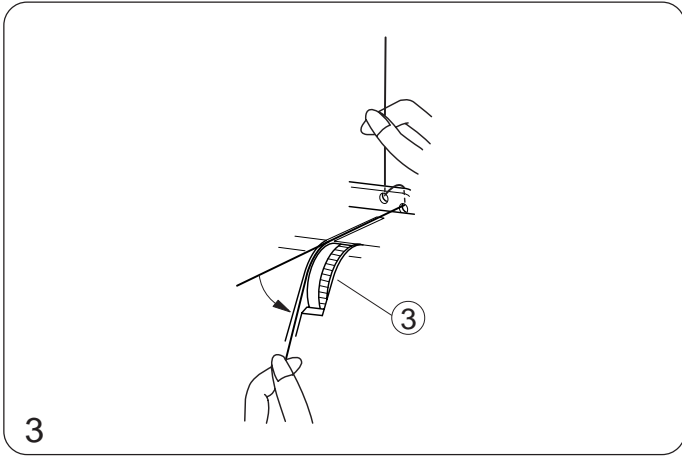

3. Hold the thread at both ends and tug gently to ensure the thread is correctly inserted between the tension discs. (If the presser foot lifter is raised, the thread easily inserts between the tension discs.)

③ Upper looper thread tension dial

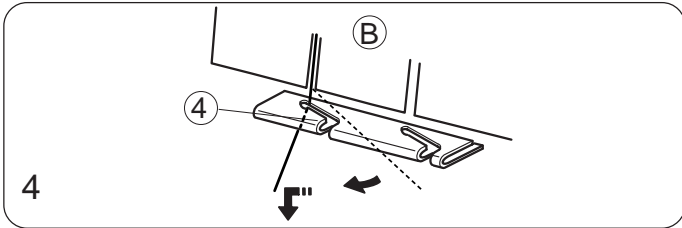

4. Hook the thread on the corner **B**, and then pass the thread through the looper thread guide.

④ Looper thread guide

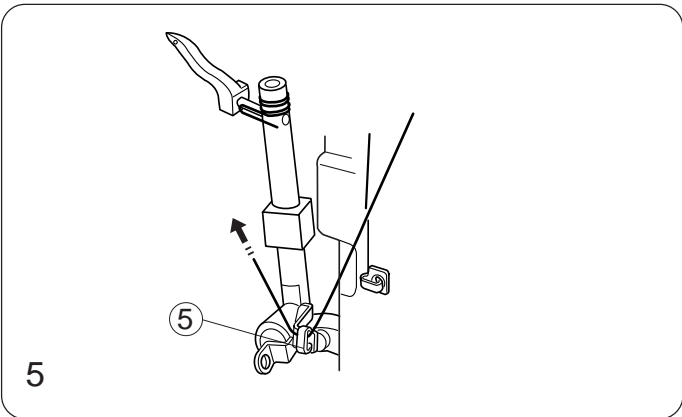

5. Pass the thread through the looper thread take-up lever (upper).

⑤ Looper thread take-up lever (upper)

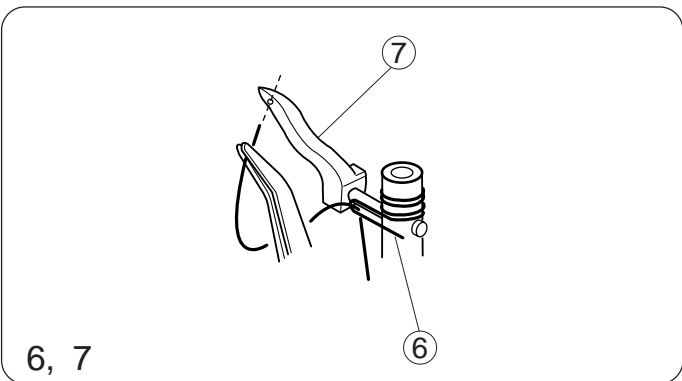

6. Pass the thread through upper looper thread guide.

7. Holding the end of the thread with a pair of tweezers, pass it through the hole on the upper looper. Pull 10 cm (4") or more of thread through the hole.

⑥ Upper looper thread guide

⑦ Upper looper

**NOTE:**

\* When you thread the upper looper only, to avoid tangled threads pull out both threads over the needle plate and under the presser foot.

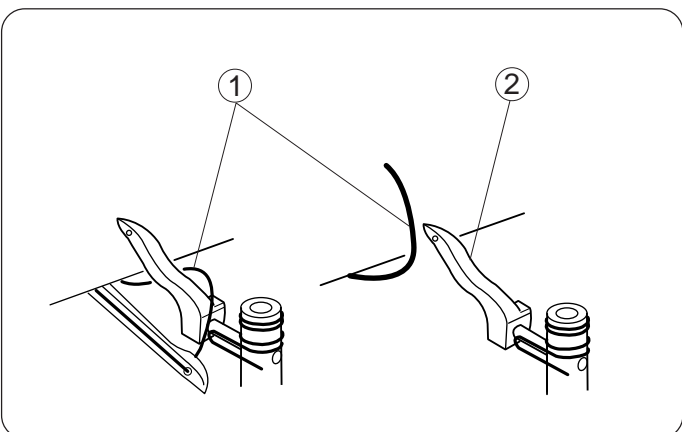

Turn the handwheel toward you until the upper looper comes to the middle point of its travel, and unhook the thread of the lower looper from the upper looper. Thread the upper looper.

① Lower looper thread

② Upper looper

• **Threading the Needle on the Right**

Place the spool of thread on the spool pin second from the left.

- \* The points to thread for needle on the right are marked in blue.
- \* A convenient threading chart is placed on the machine body inside the looper cover.

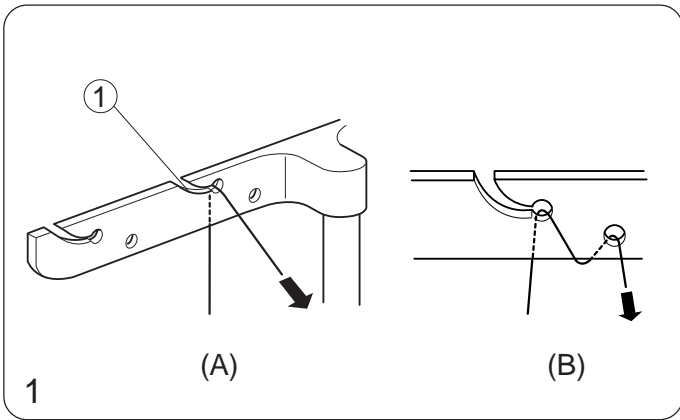
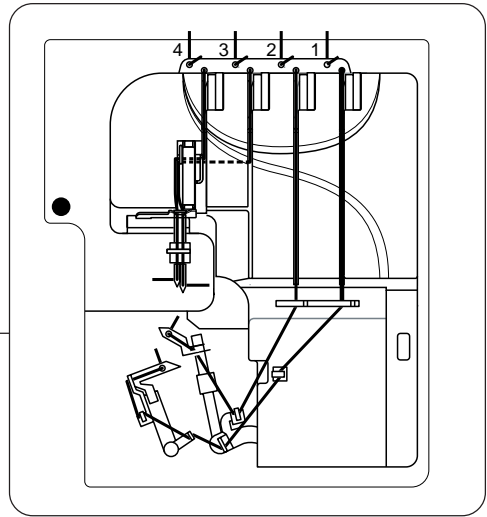
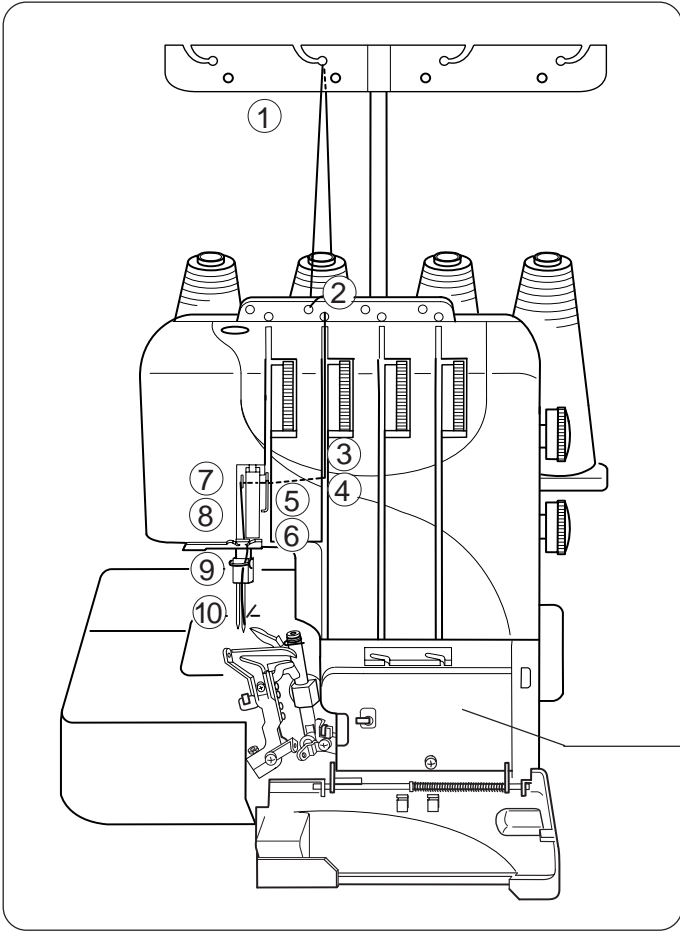

1. Draw the thread through the thread guide second from the left from back to front: (A)

- \* If the thread is coming out from the thread guide groove, pass the thread through the thread guide hole again as shown: (B)

① Thread guide

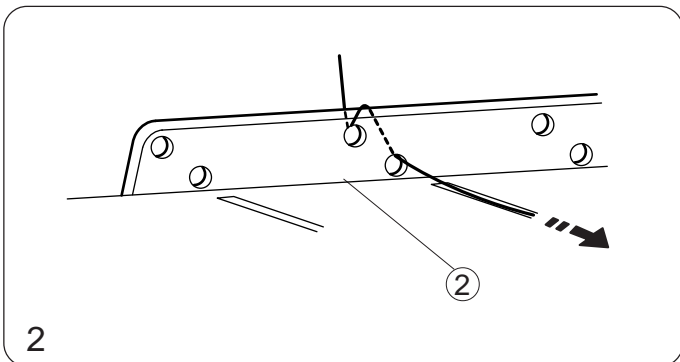

2. Pass the thread through the holes in the second row from the left of the thread guide plate as illustrated.

② Thread guide plate

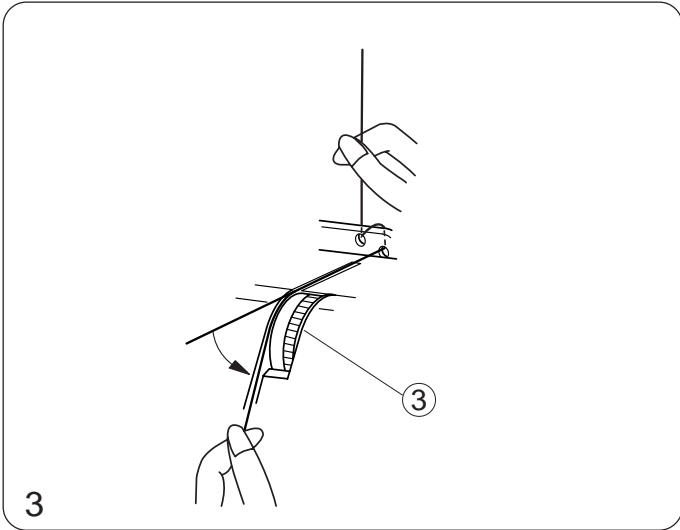

3. Hold the thread at both ends and tug gently to ensure the thread is correctly inserted between the tension discs. (If the presser foot lifter is raised, the thread easily inserts between the tension discs.)

③ Right needle thread tension dial

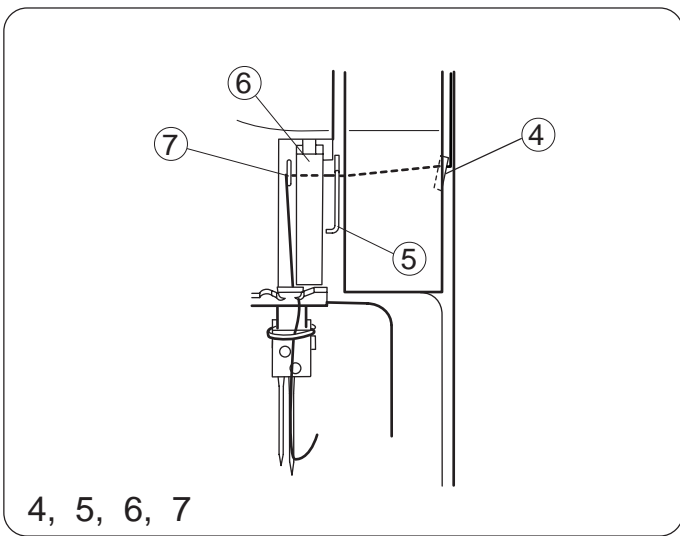

- 4,5,6. After passing through the front cover thread guide (1), pass the thread from the bottom of the front cover thread guide (2) and the take-up lever cover from right to left.

7. Guide the thread over the front cover thread guide (3).

④ Front cover thread guide (1)

⑤ Front cover thread guide (2)

⑥ Take-up lever cover

⑦ Front cover thread guide (3)

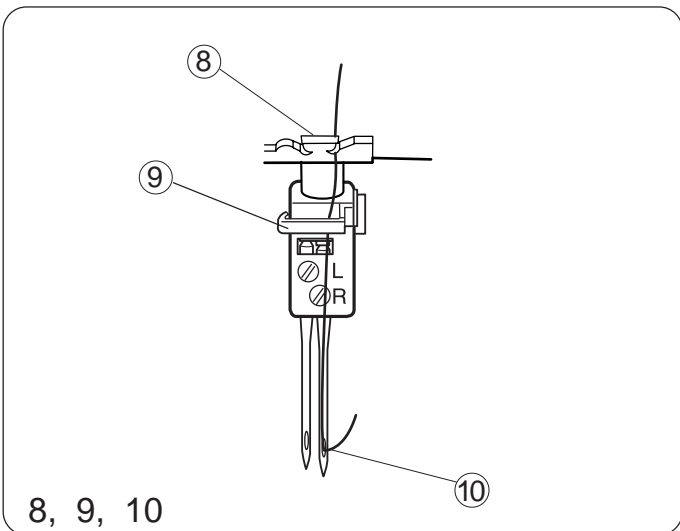

8. Insert the thread into the right slot of needle thread guide plate.

9. Raise the needle to its highest point and pass the thread through the needle bar thread guide from left to right.

10. Thread the right needle from front to back and pull the thread about 10 cm (4") from the eye of the needle to the back.

⑧ Needle thread guide

⑨ Needle bar thread guide

⑩ Right needle

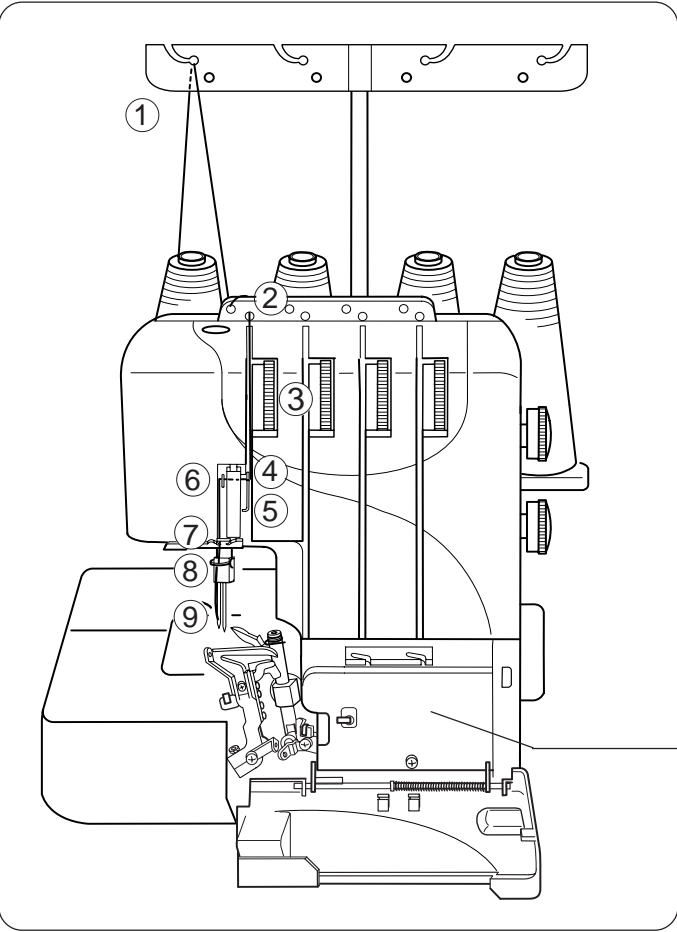

**• Threading the Needle on the Left**

Place the spool of thread on the left side spool pin.

- \* The points to thread for needle on the left are marked in orange.
- \* A convenient threading chart is placed on the machine body inside the looper cover.

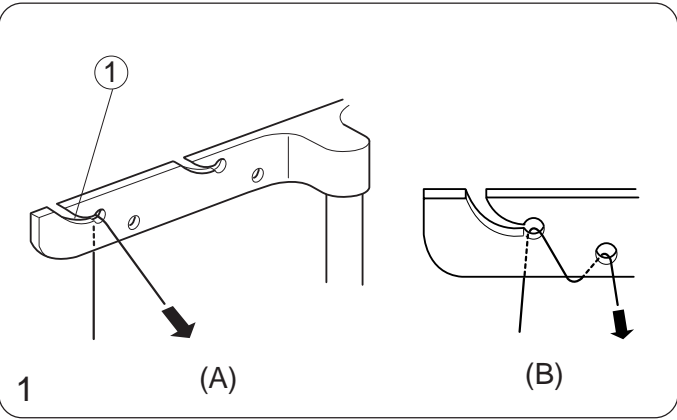
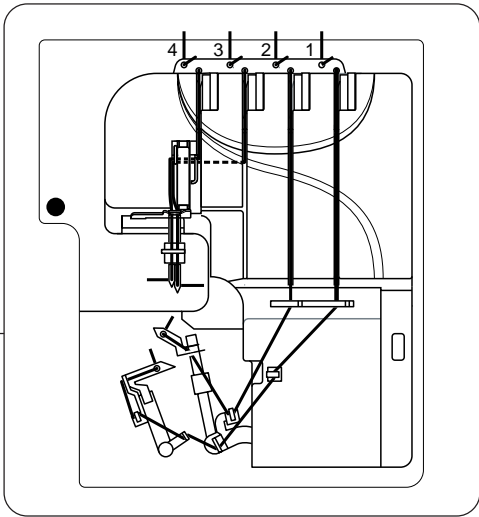

1. Draw the thread through the thread guide on the left from back to front: (A)

- \* If the thread is coming out from the thread guide groove, pass the thread through the thread guide hole again as shown: (B)

① Thread guide

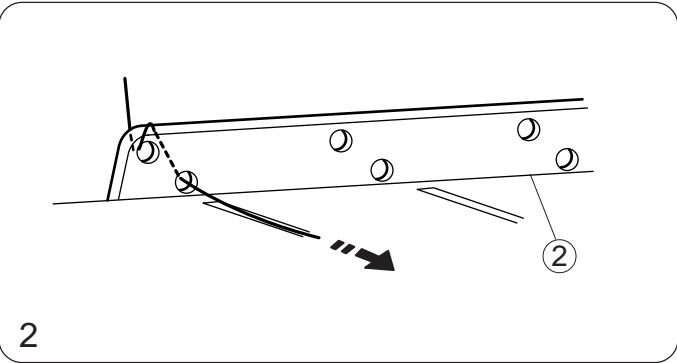

2. Pass the thread through the holes on the left of thread guide plate as illustrated.

② Thread guide plate

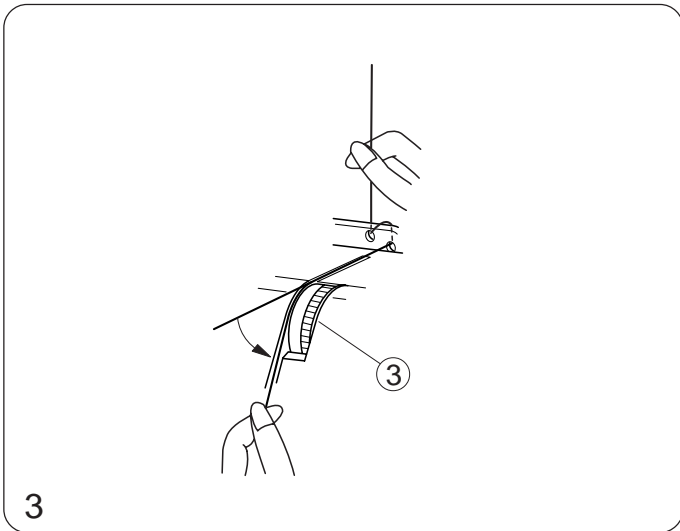

3. Hold the thread at both ends and tug gently to ensure the thread is correctly inserted between the tension discs. (If the presser foot lifter is raised, the thread easily inserts between the tension discs.)

③ Left needle thread tension dial

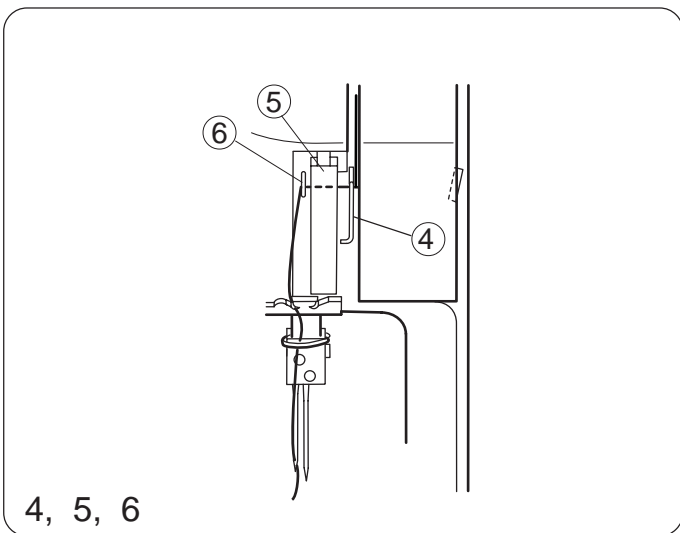

4,5 Slide the thread from the bottom of front cover thread guide (2) and the take-up lever cover right to left.

6. Guide the thread over the front cover thread guide (3).

④ Front cover thread guide (2)

⑤ Take-up lever cover

⑥ Front cover thread guide (3)

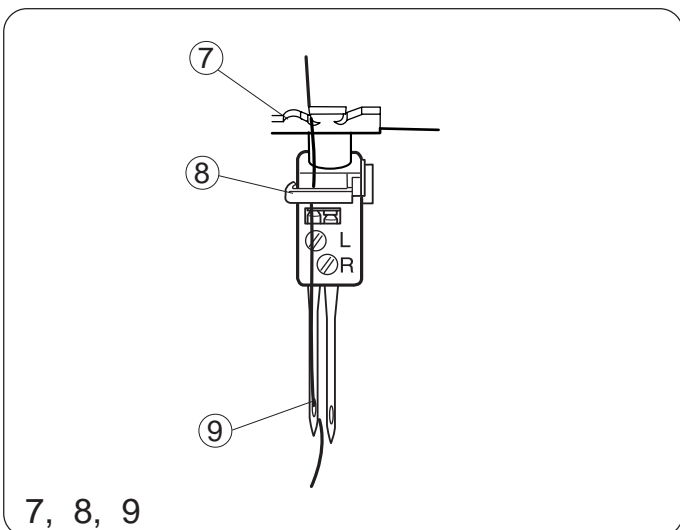

7. Insert the thread into the left slot of the needle thread guide plate.

8. Raise the needle to its highest point and pass the thread through the needle bar thread guide from left to right.

9. Thread the left needle from front to back and pull the thread about 10 cm (4") from the eye of the needle to the back.

⑦ Needle thread guide plate

⑧ Needle bar thread guide

⑨ Left needle

- Gently pull all four thread ends towards the back of the machine.
- Run threads under the presser foot and lower the presser foot.
- Close side cover and looper cover.
- Turn handwheel toward you to chain off three or four stitches.

The sewing preparation is now complete.

## TEST STITCHING

### Starting Sewing

1. Insert the fabric under the toe of the foot.  
(It is not necessary to raise the foot.)
  2. Turn the handwheel gently toward you a couple of turns and check the thread chain. Then start sewing slowly. The fabric will be automatically fed. Guide the fabric in the desired direction.
- \* For heavyweight fabric, raise the presser foot and insert the fabric in front of the knife. Then lower the foot and start to sew while guiding the fabric.

### Finishing Sewing

1. When stitching is completed, continue to run the machine slowly to produce a thread chain for about 12 cm (5'') while pulling the thread chain slightly to the back.

2. Cut the threads with the thread cutter as illustrated, leaving about 5 cm (2'') thread chain from the end of the fabric.

① Thread cutter

- \* The thread cutter becomes blunt as loose threads build up. Remove the loose threads collected in the thread cutter.

### Sewing Continuously

Insert the next fabric under the toe of the foot, then start sewing. It is not necessary to raise the presser foot for ordinary fabric.

- \* For heavyweight fabric, raise the presser foot and insert the fabric in front of the knife. Then lower the foot and start to sew while guiding the fabric.

### How to use Guide Lines

On the top of the looper cover are guide lines indicating the distance from the needle position.

Please use them as sewing guides.

Mark L indicates the distance from the left needle.

Mark R indicates the distance from the right needle.

The distance between center of guide line and needle position is 5/8 inch.

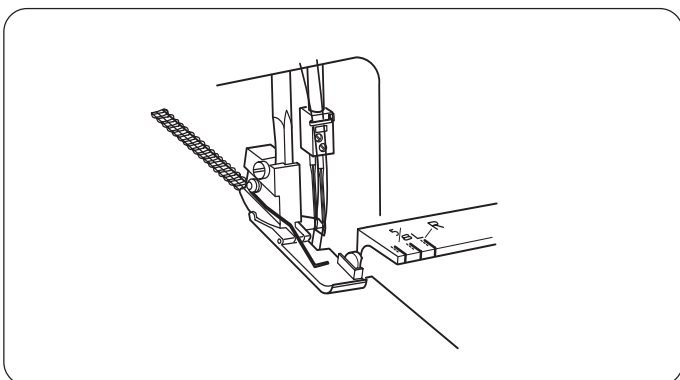
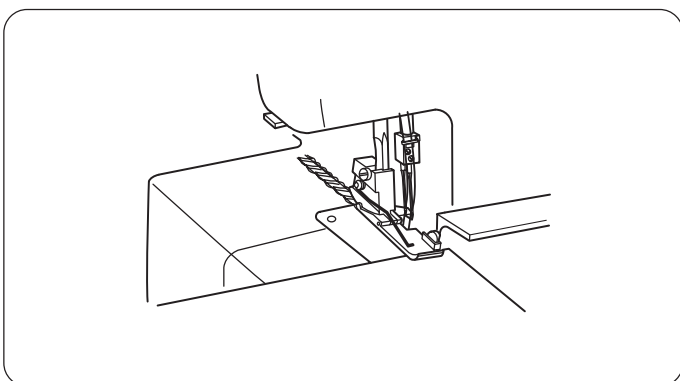
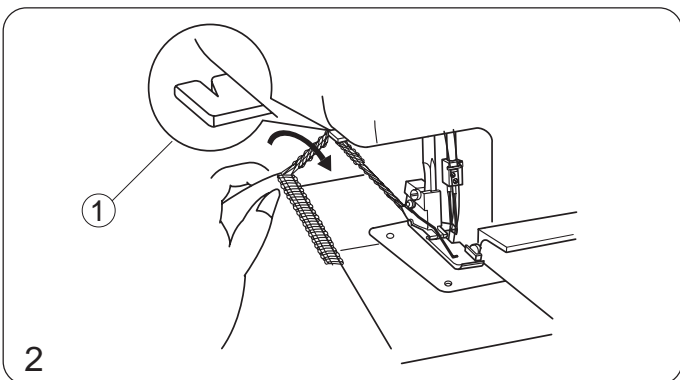
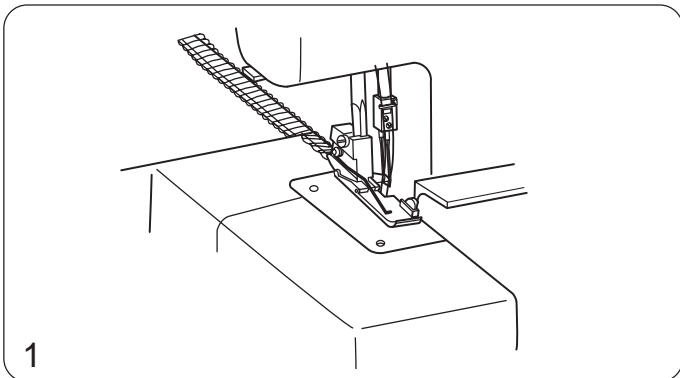
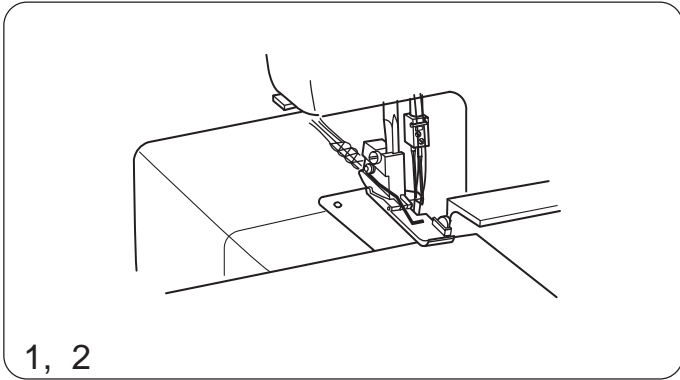

## Securing Ends

To avoid unravelling, it is necessary to leave a thread chain about 5 cm (2'') long at the beginning and at the end of a seam. To secure the beginning and end of a seam choose one of the following methods.

### At the beginning

- A. Separate the end of the threads and knot them.
- B. Thread the chain through a large eyed needle, and weave the chain through the overlock stitches on the fabric.
- C. Cut the chain at the edge of the fabric. Then apply a small amount of seam sealant (Fray Check™ or Fray-No-More™) on the end of the threads.

- D. 1. Before putting your fabric in the machine, sew a thread chain about 5 cm (2'') long behind the needle.
2. Put your fabric on the machine. Then serge a few stitches and stop.
3. Raise the presser foot and bring the thread chain from the left, around and under the presser foot.
4. Place the thread chain between the presser foot and upper knife, holding it in position as you lower the presser foot to sew.
5. After sewing about 2.5 cm (1''), move the chain to the right and under the upper knife, cutting the chain as you sew.

### At the end of a seam

\* You can use the same methods as "At the beginning" to secure the end of a seam except "D" or you can use the methods shown below.

1. Serge one stitch off the end of a seam.
2. Raise the needle and presser foot, and gently pull the threads off the chaining finger.
3. Turn the fabric over so that the under side is up.
4. Serge about 2.5 cm (1'') over stitching and angle off the fabric.

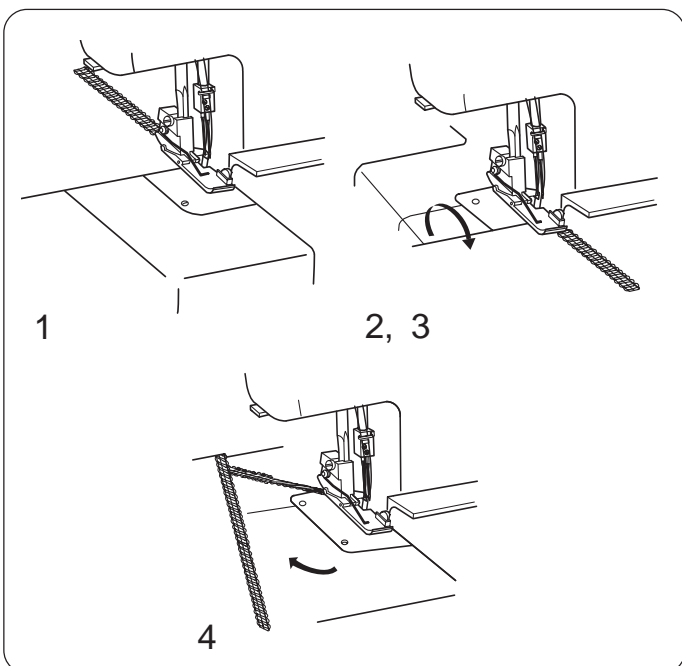
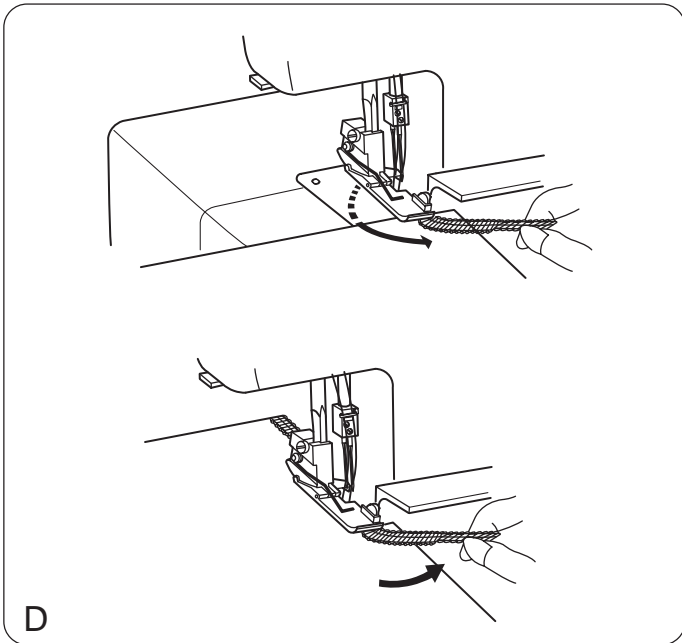
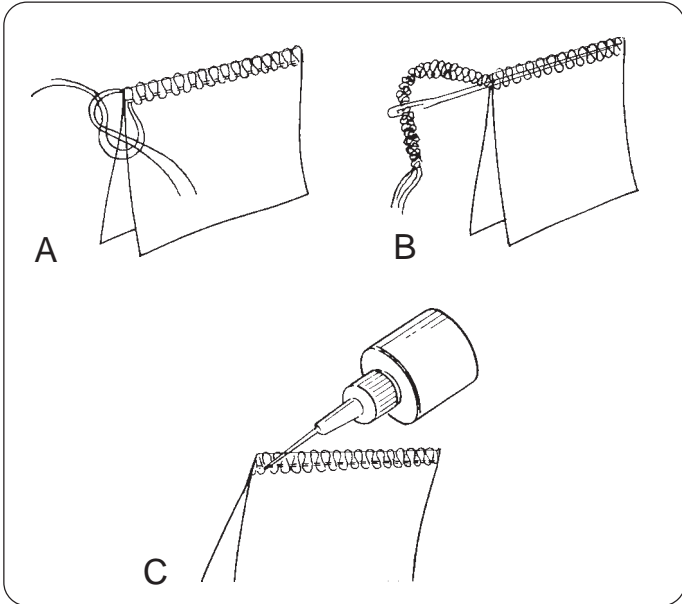



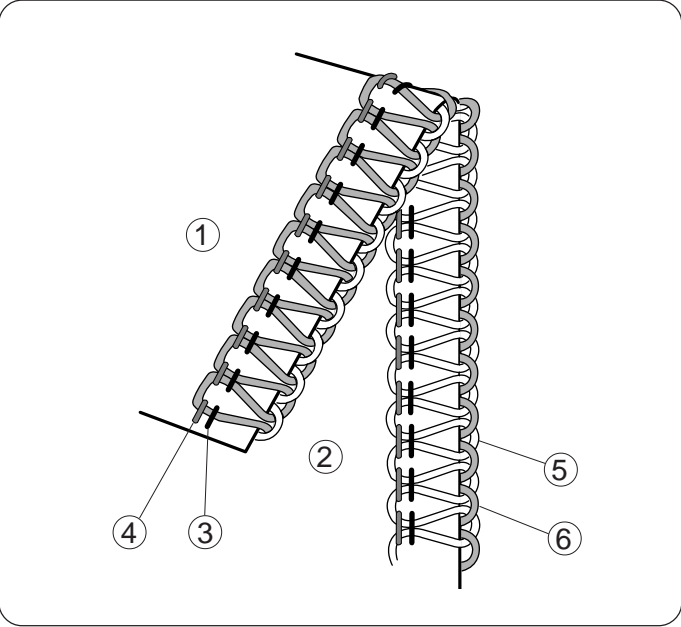

**Thread Tension (4 threads)**

**Correct tension**

The illustration at left shows sewing results with correct tension settings. However, adjusting the thread tension may be required depending upon the type of fabric and thread being used.

- ① Wrong side of fabric
- ② Right side of fabric
- ③ Right needle thread
- ④ Left needle thread
- ⑤ Upper looper thread
- ⑥ Lower looper thread

**Thread tension adjustment**

\* Set all four thread tension dials at "3". Then sew, and check the thread tensions.

If the tension balance on the test piece is not satisfactory, you can adjust the thread tension with the thread tension dial.

- ⑦ Thread tension dial
- ⑧ Setting mark
- ⑨ Loosen
- ⑩ Tighten

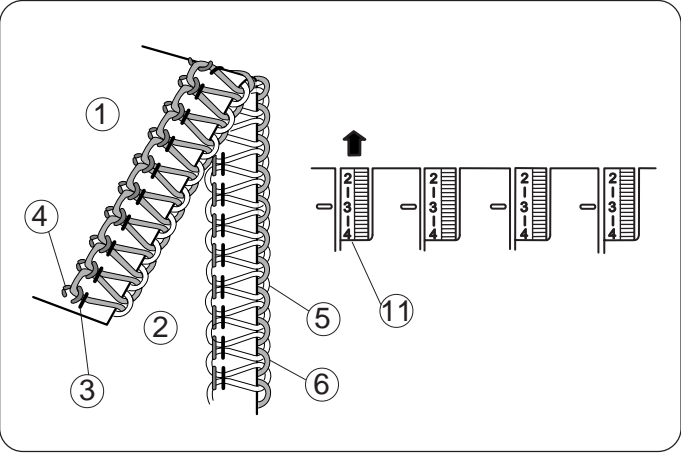

**Left needle thread tension is too loose**

The illustration shows sewing results when the left needle thread tension is too loose.

Remedy:  
Tighten the left needle thread tension.

- ⑪ Left needle thread tension dial

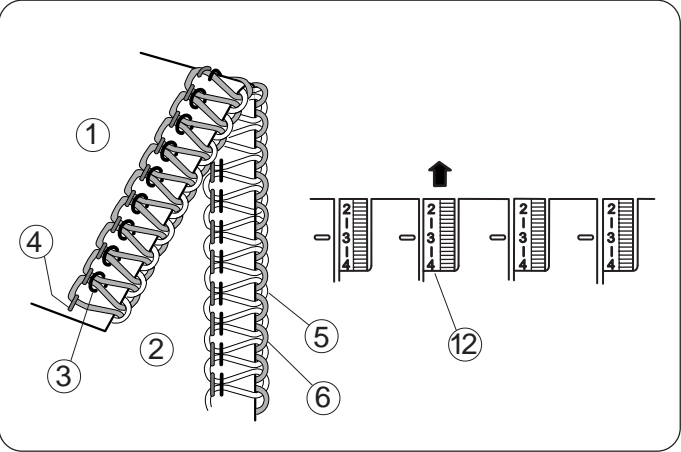

**Right needle thread tension is too loose**

The illustration shows sewing results when the right needle thread tension is too loose.

Remedy:  
Tighten the right needle thread tension.

- ⑫ Right needle thread tension dial

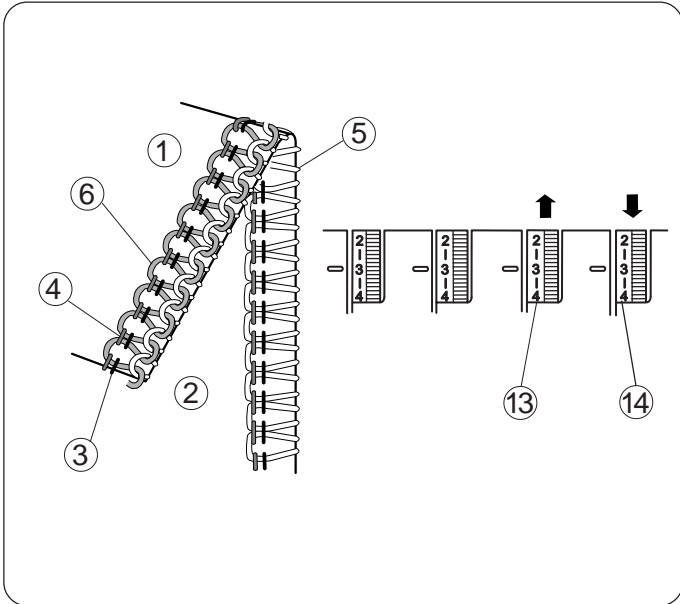

### **Looper thread tension is out of balance (1)**

The illustration shows sewing results when the lower looper thread tension is too tight and/or upper looper thread tension is too loose.

Remedy:

Loosen lower looper thread tension and/or tighten upper looper thread tension.

- ① Wrong side of fabric
- ② Right side of fabric
- ③ Right needle thread
- ④ Left needle thread
- ⑤ Upper looper thread
- ⑥ Lower looper thread
- ⑬ Upper looper thread tension dial
- ⑭ Lower looper thread tension dial

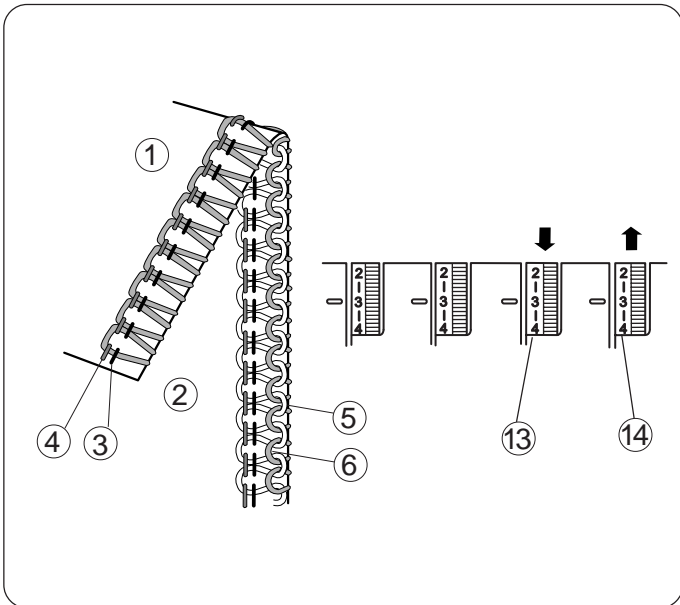

### **Looper thread tension is out of balance (2)**

The illustration shows sewing results when the upper looper thread tension is too tight and/or lower looper thread tension is too loose.

Remedy:

Loosen upper looper thread tension and/or tighten lower looper thread tension.

- ⑬ Upper looper thread tension dial
- ⑭ Lower looper thread tension dial

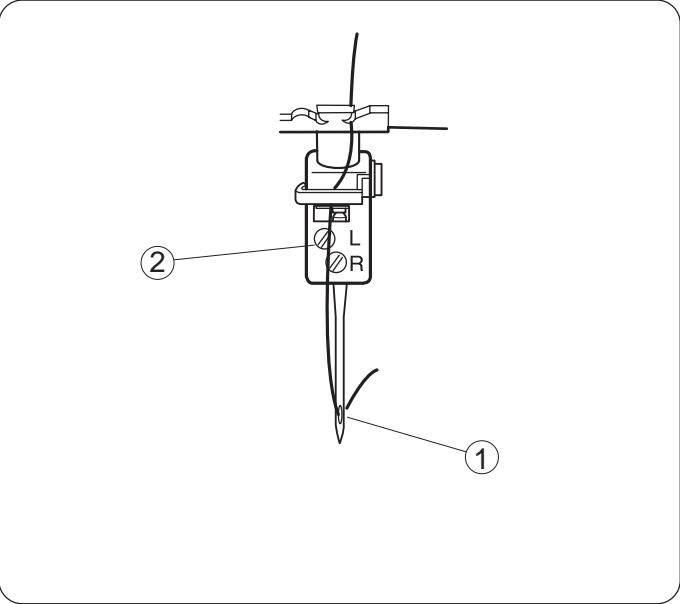

**Threading the Machine (3 threads)**

**Using the needle on the right only  
(for regular three-thread serging)**

Turn off the power switch and unplug the machine. Remove the needle and the thread on the left. Then retighten the needle clamp screw on the left to prevent losing the screw.

- ① Needle on the right
- ② Needle clamp screw on the left

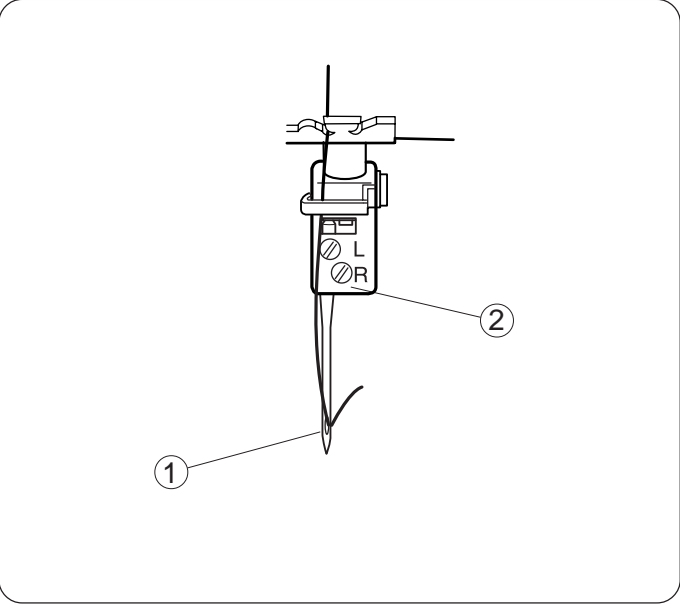

**Using the needle on the left only  
(for wide three-thread serging)**

Turn off the power switch and unplug the machine. Remove the needle and the thread on the right. Then retighten the needle clamp screw on the right to prevent losing the screw.

- ① Needle on the left
- ② Needle clamp screw on the right

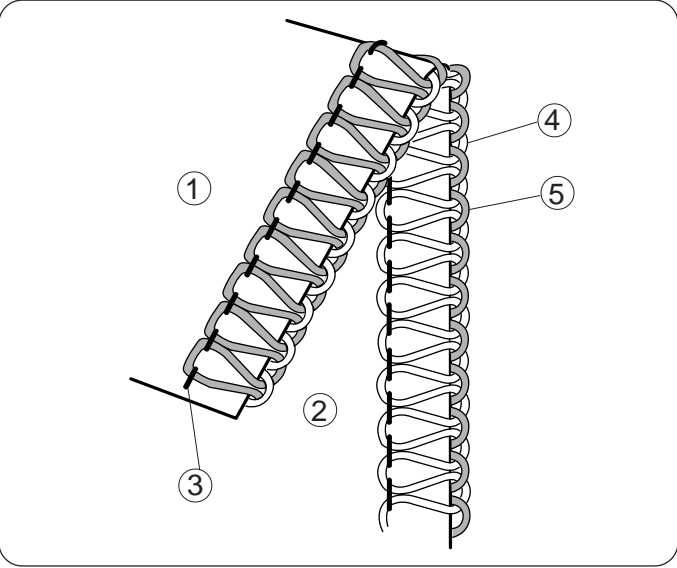

**Thread Tension (3 threads)**

**Correct tension**

The illustration at left shows sewing results with correct tension settings. However, adjusting the thread tension may be required depending on the type of fabric and thread being used.

- ① Wrong side of fabric
- ② Right side of fabric
- ③ Right or left needle thread
- ④ Upper looper thread
- ⑤ Lower looper thread

**Thread tension adjustment**

\* Set all three thread tension dials at “3”. Then sew, and check the tension balance. If the tension balance on the test piece is not satisfactory, you can adjust the thread tension with thread tension dial.

- ⑥ Thread tension dial
- ⑦ Setting mark
- ⑧ Loosen
- ⑨ Tighten

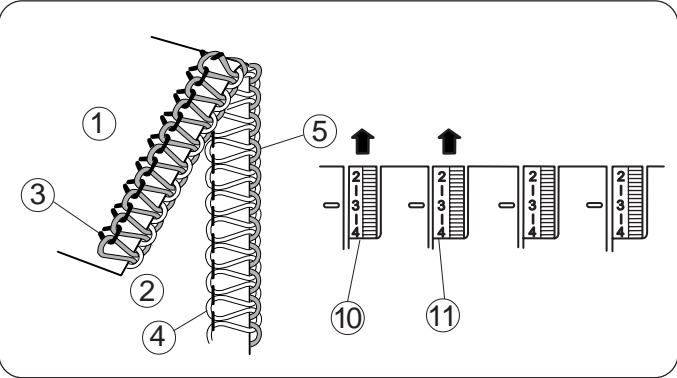
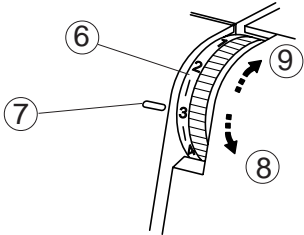

**Needle thread tension is too loose**

The illustration shows sewing results when the needle thread tension is too loose.

Remedy:  
Tighten needle thread tension.

- ⑩ Left needle thread tension dial
- ⑪ Right needle thread tension dial

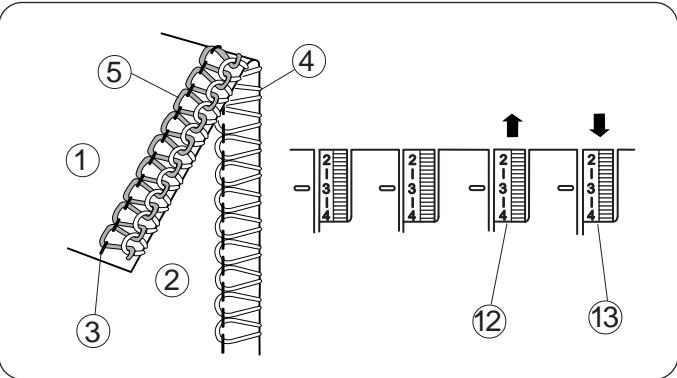

**Looper thread tension is out of balance (1)**

The illustration shows sewing results when the lower looper thread tension is too tight and/or upper looper thread tension is too loose.

Remedy:  
Loosen lower looper thread tension and/or tighten upper looper thread tension.

- ⑫ Upper looper thread tension dial
- ⑬ Lower looper thread tension dial

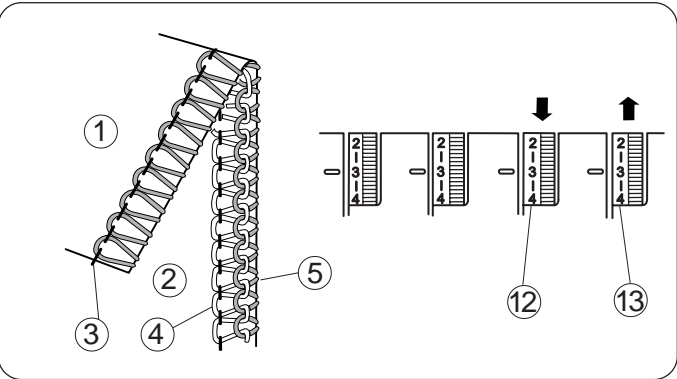





**Looper thread tension is out of balance (2)**

The illustration shows sewing results when the upper looper thread tension is too tight and/or lower looper thread tension is too loose.

Remedy:  
Loosen upper looper thread tension and/or tighten lower looper thread tension.

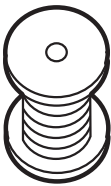
- ⑫ Upper looper thread tension dial
- ⑬ Lower looper thread tension dial

## Thread and Needle Chart

Type of fabric		Type of thread	Needle	Stitch length	Differential feed ratio
					
<b>Lightweight</b>	Organdy, Georgette, Lawn, Crepe de chine, Lining.	Cotton: No. 80 – 100 Silk: No. 80 – 100 Synthetic: No. 80 – 100	HA-1 SP No. 11	2.0 – 3.0	0.5 – 1.0
<b>Mediumweight</b>	Cotton, Linen, Satin, Ordinary fabric.	Cotton: No. 60 – 100 Silk: No. 50 – 100 Synthetic: No. 60 – 100	HA-1 SP No. 11 – 14	2.5 – 3.5	1.0
<b>Heavyweight</b>	Tweed, Coating, Denim, Doeskin, Thick fabric.	Cotton: No. 50 – 60 Silk: No. 50 – 60 Synthetic: No. 50 – 60	HA-1 SP No. 14	3.0 – 4.0	1.0
<b>Knits</b>	Knitted fabric.	Cotton: No. 60 – 80 Synthetic: No. 60 – 90 Woolly nylon (For looper thread) Woolly polyester (For looper thread)	HA-1 SP No. 11 – 14	2.5 – 4.0	1.0 – 2.2

\* Refer to page 20 for adjusting the stitch length and differential feed ratio.

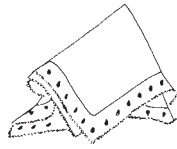

**NOTE:** Your overlock uses standard sewing needles (HA-1 SP, No.11, No.14).

# ROLLED HEMMING, PICOT EDGING AND NARROW HEMMING

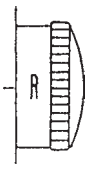
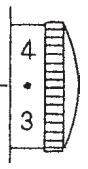
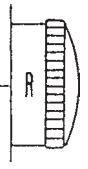
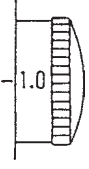
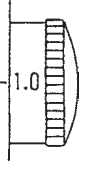
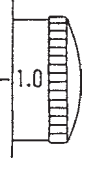
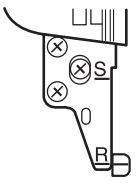
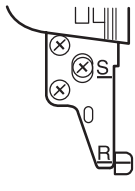

## Machine Setting and Thread, Fabric and Range of the Tension Dial

The setting of tension dials may vary depending on the type and thickness of fabric and thread being sewn.

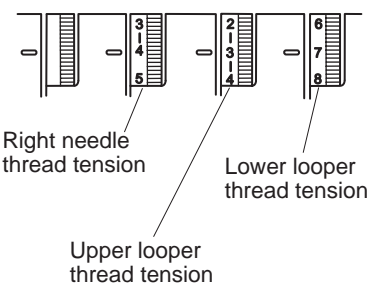
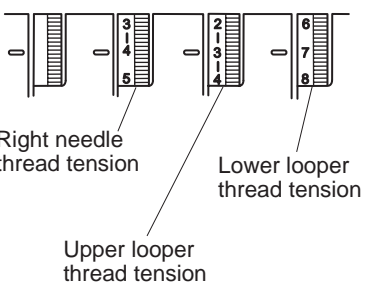
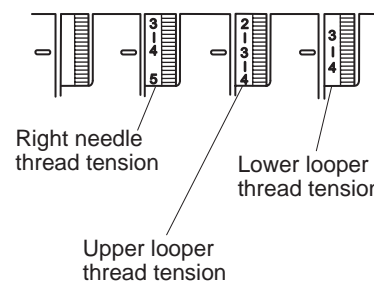
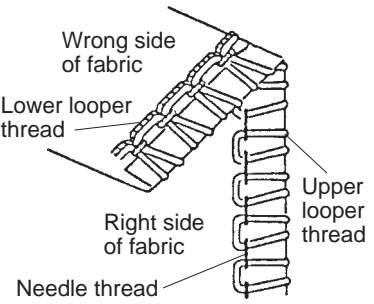
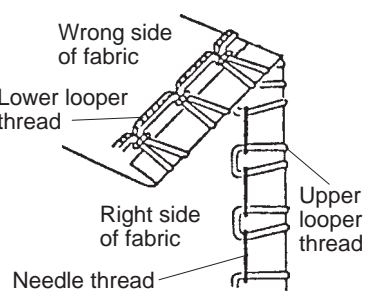
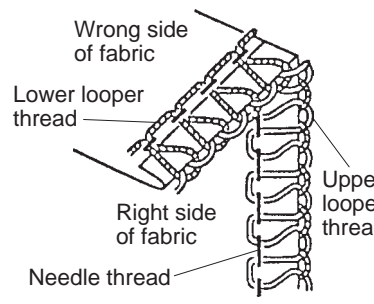
	Rolled Hemming	Picot Edging	Narrow Hemming
<b>Stitch Length</b>	 (R)	 (3 ~ 4)	 (R)
<b>Differential Feed Ratio</b>	 (1.0)	 (1.0)	 (1.0)
<b>Needle Plate Setting Knob</b>	 (R)	 (R)	 (R)
<b>Needle</b>	Using the needle on the right: HA-1 SP No. 11		
<b>Needle Thread</b>	Synthetic: No. 80 ~ 100		
<b>Upper and Lower Loper Threads</b>	Woolly nylon, Woolly polyester Synthetic: No. 80 ~ 100	Synthetic : No. 60 ~ 100 Silk : No. 50 ~ 100	Woolly nylon, Woolly polyester Synthetic: No. 80 ~ 100
<b>Fabric</b>	Lightweight fabric such as Organdy, Crepe de chine, Lawn and Georgette		
<b>Standard Setting of Tension Dials</b>			
<b>Correct Thread Tension</b>			

## Thread Tension

### For rolled hemming and picot edging Correct tension

The illustration at left shows sewing results with correct tension settings.

Adjusting the thread tension may be required depending on the type of fabric and thread being used.

- ① Wrong side of fabric
- ② Right side of fabric
- ③ Right needle thread
- ④ Upper looper thread
- ⑤ Lower looper thread

### Thread tension adjustment

1. Set the tension dial as shown on page 62.
2. Sew and check the tensions.
3. If the tension balance on the test piece is not satisfactory, you can adjust the thread tension with thread tension dial.

### Needle thread tension is too loose

The illustration shows the sewing results when the right needle thread tension is too loose.

Remedy:

Tighten the right needle thread tension.

- ⑥ Right needle thread tension dial

### Upper looper thread tension is too loose

The illustration shows the sewing results when the upper looper thread tension is too loose.

Remedy:

Tighten the upper looper thread tension.

- ⑦ Upper looper thread tension dial

### Looper thread tension is out of balance

The illustration shows sewing results when the upper looper thread tension is too tight and/or lower looper thread tension is too loose.

Remedy:

Loosen upper looper thread tension and/or tighten lower looper thread tension.

- ⑦ Upper looper thread tension dial
- ⑧ Lower looper thread tension dial

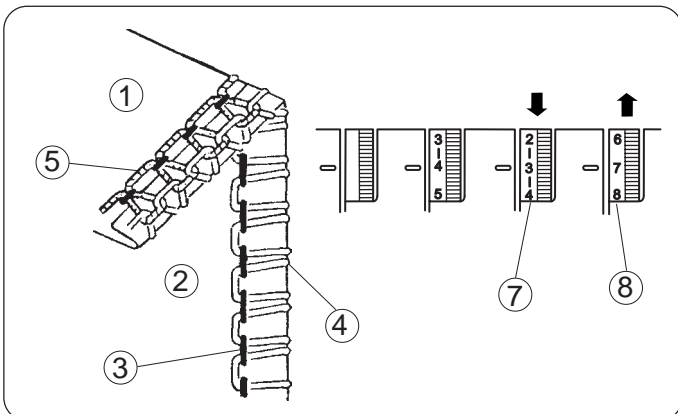
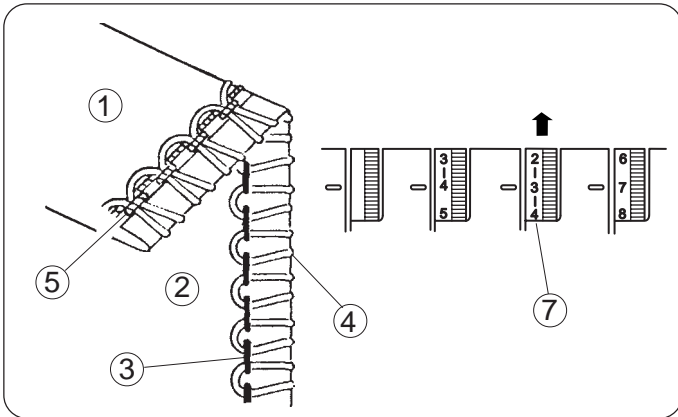
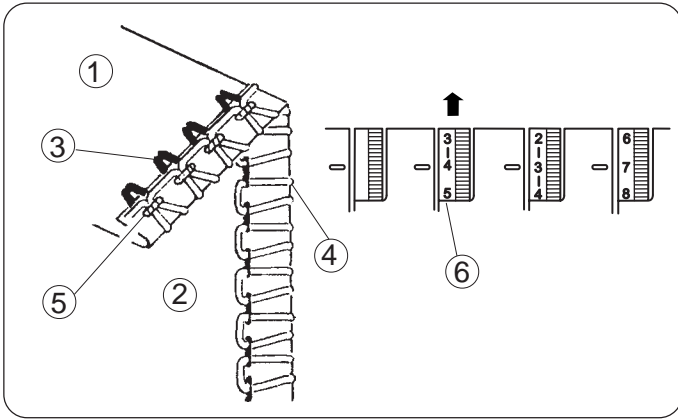
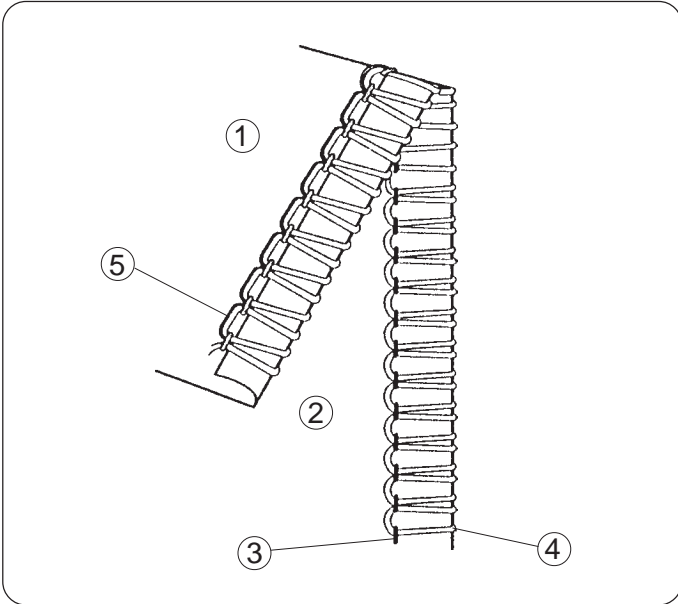

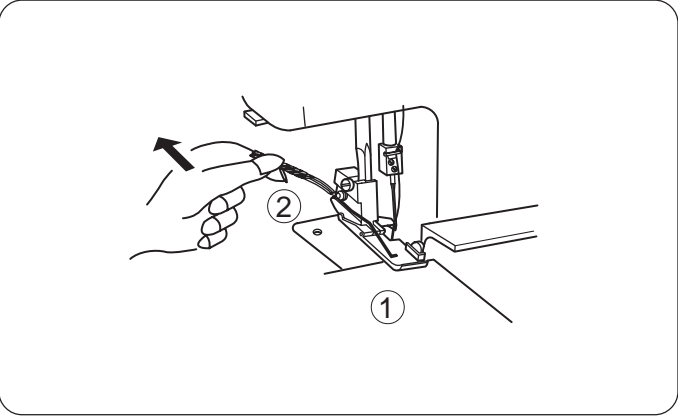

**For Better Results**

**Rolled hemming**

Pull the end of thread chain to the back lightly in the beginning and end of sewing.

- ① Fabric
- ② Thread chain

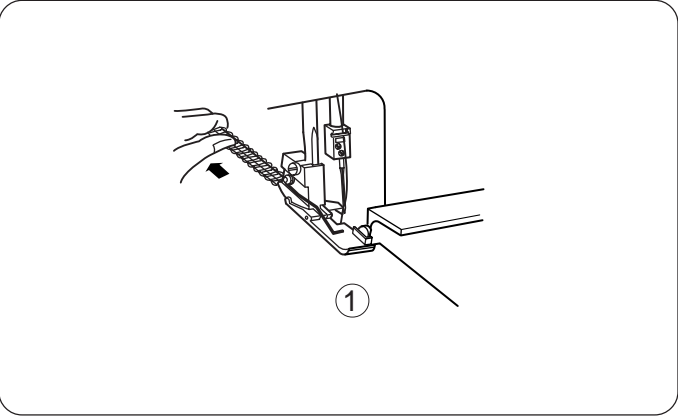

**Picot edging**

Pull the fabric lightly to the back while sewing.

- ① Fabric

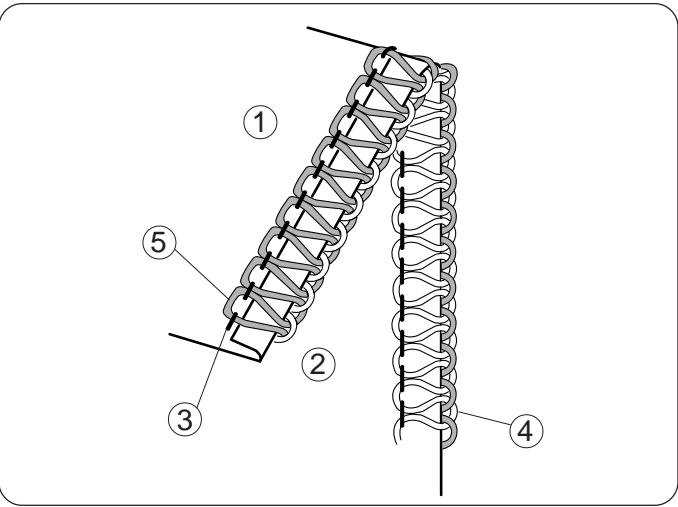

**For narrow hemming**

**Correct tension**

The illustration at left shows sewing results with correct tension settings.

- ① Wrong side of fabric
- ② Right side of fabric
- ③ Right needle thread
- ④ Upper looper thread
- ⑤ Lower looper thread

\* Refer to pages 58 for the adjustment.



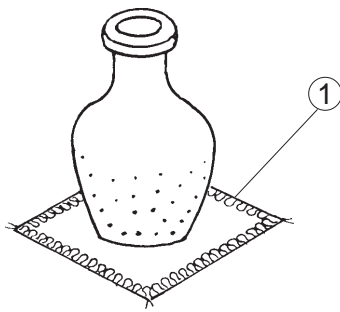

## DECORATIVE OVEREDGING

- \* Refer to pages 52, 54, 58 for thread tension balance adjustment.
- \* For the best results, pull the thread chain to the back lightly at the beginning and end of sewing.

① Overedging

### Thread and Fabric

Fabric	Thread	
<b>Medium to Heavy Fabric</b>	Needle threads	Synthetic : No. 60~80 Silk : No. 50~80
	Upper looper thread	Buttonhole twist Light weight wool yarn
	Lower looper thread	Synthetic : No. 60~80 Silk : No. 50~80

### Machine Setting

- ① Needle plate setting knob : S
- ② Upper knife : up

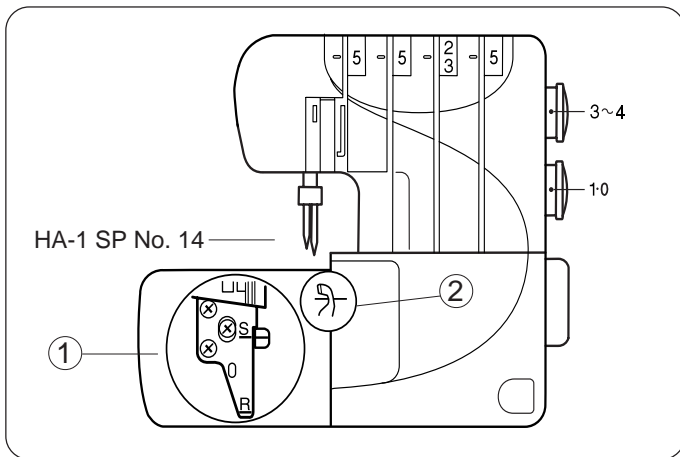

## GATHERING

- \* Refer to pages 52, 54, 58 for thread tension balance adjustment.

① Gathering

### Thread and Fabric

Fabric	Thread	
<b>Light to Medium Woven Fabric</b>	Needle threads	Synthetic : No. 60~80 Silk : No. 50~80
	Upper looper thread Lower looper thread	Synthetic : No. 60~80 Silk : No. 50~80

### Machine Setting

- ① Needle plate setting knob : S
- ② Upper knife : Up

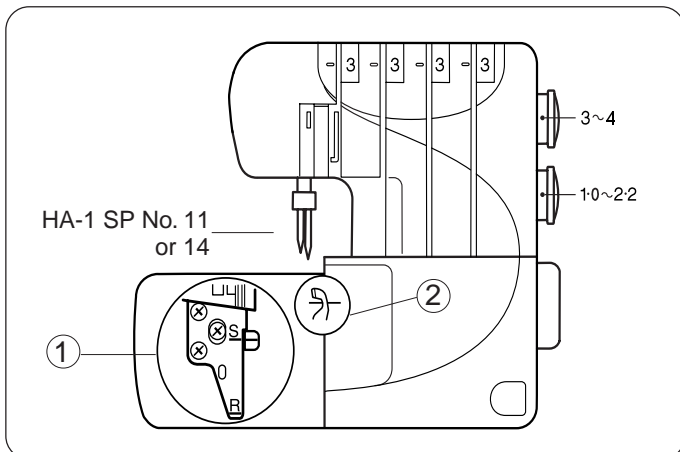

## PIN TUCKING

\* Refer to page 62 (Narrow Hemming) for thread tension balance adjustment.

① Pin tucking

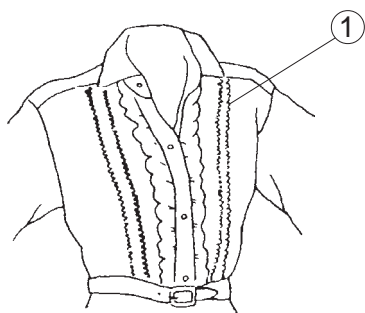

### Thread and Fabric

Fabric	Thread	
Light to Medium Fabric	Needle thread on the right	Synthetic : No. 60~80 Silk : No. 50~80
	Upper looper thread Lower looper thread	Synthetic : No. 60~100 Silk : No. 50~100

### Machine Setting

- ① Remove the needle on the left-hand side
- ② Needle plate setting knob : R
- ③ Upper knife : Down

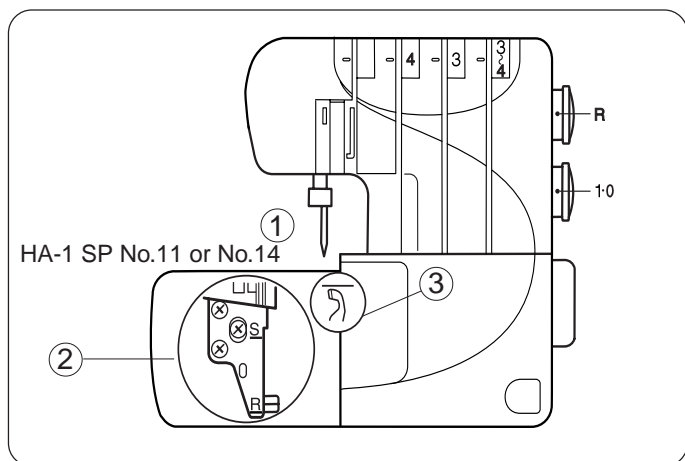

### Sewing

Turn off the power switch.  
Remove the needle on the left-hand side.  
Deactivate the upper knife.  
Turn on the power switch, then sew the folded edge while guiding along the guide line.

- ① Folded edge
- ② Guide line on the needle plate
- ③ Right needle position line on the presser foot
- ④ Left needle position line on the presser foot
- ⑤ Right side of fabric

Open the fold flat and press the pin tucks to one side.

**NOTE:** After you finish sewing, return the upper knife to the original position.

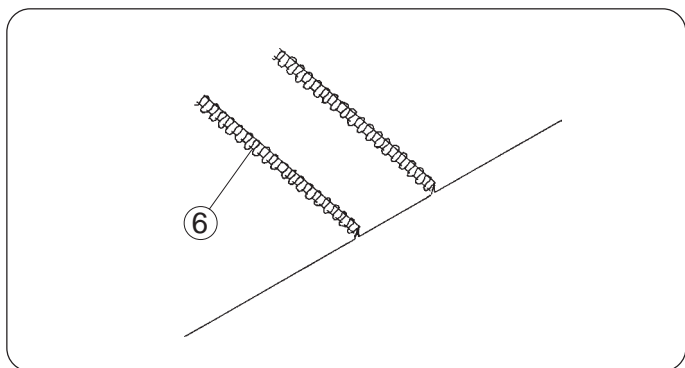
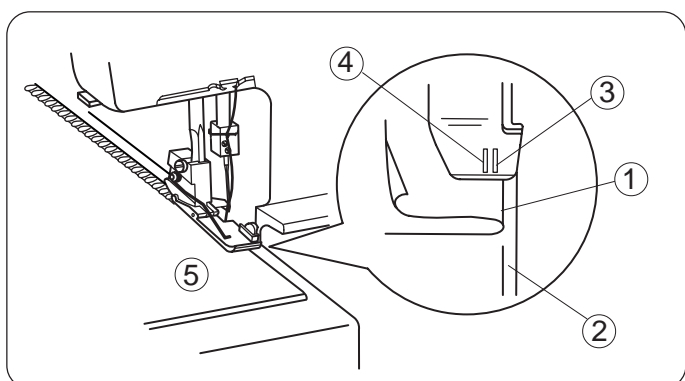

⑥ Pin tucking

## CARE OF YOUR MACHINE

### Replacing the Upper Knife

#### To remove:

1. Turn off the power switch and unplug the machine.
2. Open the looper cover and side cover.
3. Deactivate the upper knife.
4. Remove the hexagonal bolt, and remove the upper knife.

- ① Upper knife
- ② Hexagonal bolt
- ③ Stopper pin
- ④ Lower knife

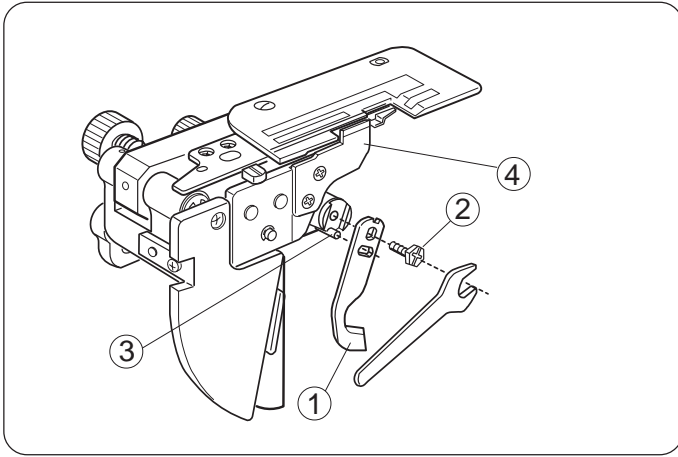

#### To attach:

1. Insert new upper knife into the groove of knife holder and stopper pin, then tighten the hexagonal bolt slightly.
2. Turn the upper knife holder to cutting position.
3. Turn the handwheel toward you until the upper knife comes to its lowest position. Loosen the hexagonal bolt, and adjust the position of the upper knife so that the edge of the upper knife overlaps 0.8 to 1.5 mm (3/64") from the edge of lower knife as illustrated. Then tighten the hexagonal bolt firmly.
4. Close the looper cover and side cover.

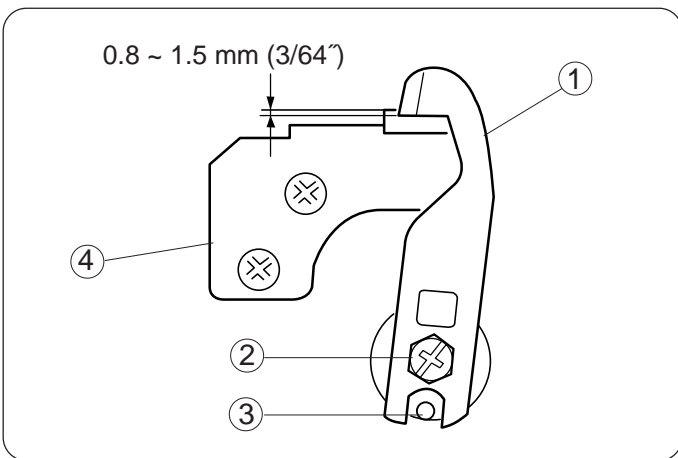

### Cleaning Upper Knife Area

1. Turn off the power switch and unplug the machine.
  2. Open the looper cover. Remove the waste pieces to the front with a lint brush.
- \* You may use a vacuum cleaner to clean the upper knife area or feed dog.
  - \* The lower knife will last over one year in normal use. However, if you run over a pin or a hard object, it may be required to replace both upper and lower knives at the same time.

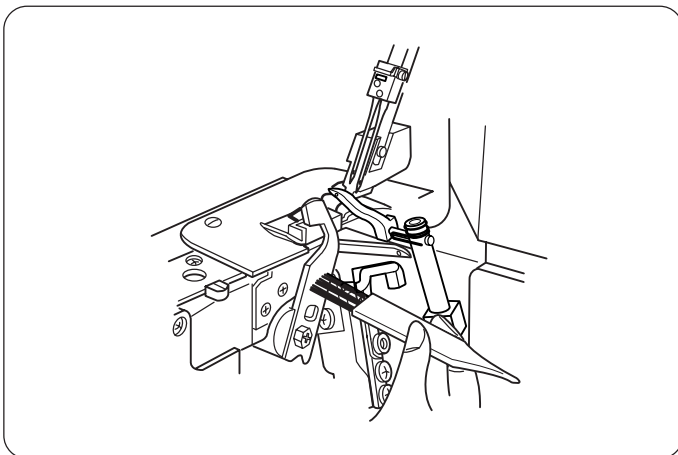

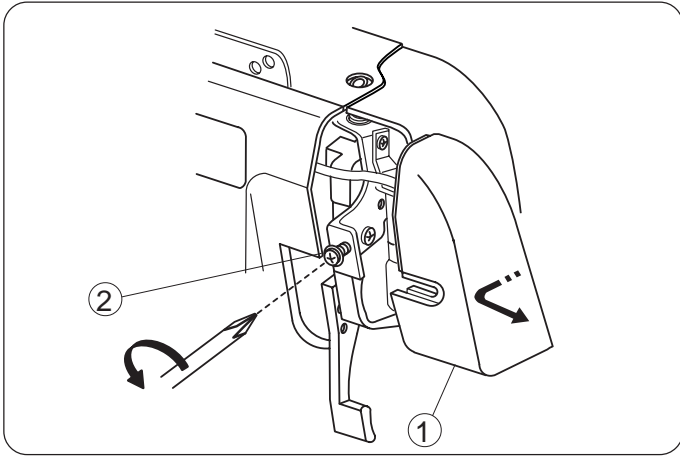

## Replacing the Light Bulb

1. Turn off the power switch and unplug the machine.
2. Loosen the face plate set screw, and remove the face plate.

- ① Face plate
- ② Set screw

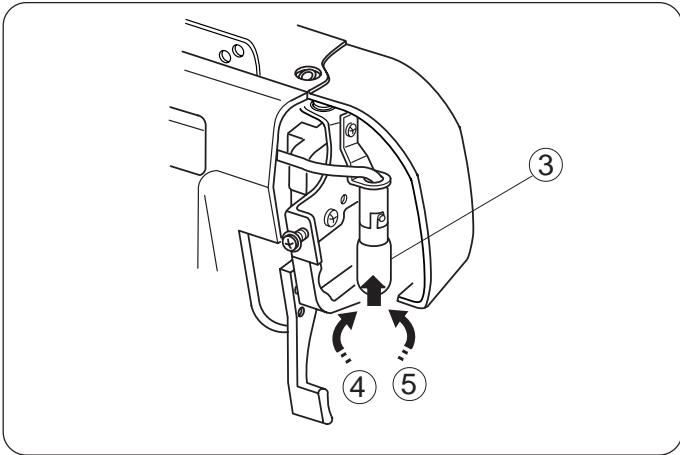

### To remove:

Push and twist to the left.

### To attach:

Push and twist to the right.

Reattach the face plate, and retighten the face plate set screw.

- ③ Light bulb
- ④ To remove
- ⑤ To attach

### **NOTE:**

- \* The machine is designed to use a 15 WATT maximum light bulb.
- \* The light bulb will be HOT. Protect your fingers when you handle it.

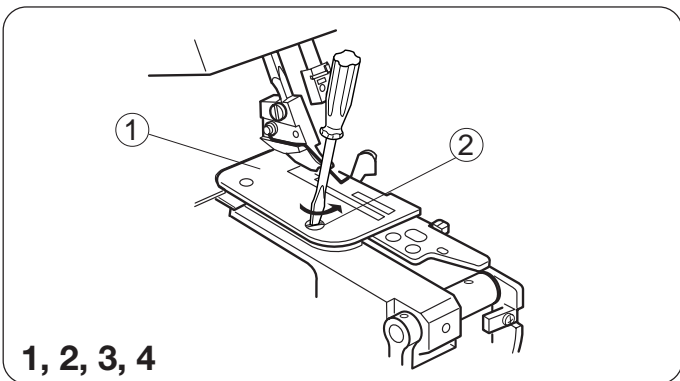

## Cleaning the Feed Dog

1. Turn off the power switch and unplug the machine.
2. Open the looper cover and side cover.
3. Remove the needles and presser foot.
4. Remove the needle plate set screw, and remove the needle plate.

- ① Needle plate
- ② Needle plate set screw

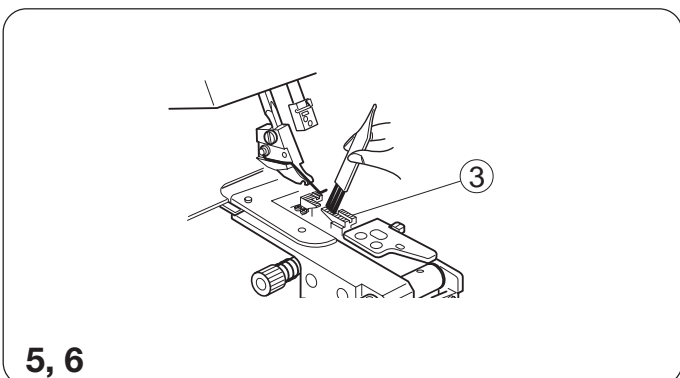

5. Brush out the lint around the feed dogs to the front by using the lint brush or use a vacuum cleaner.
6. Reattach the needle plate, presser foot and needles. Close the looper cover and side cover.

- ③ Feed dog

## Oiling the Machine

Apply a few drops of fine quality sewing machine oil to the parts indicated with arrows.

It is recommended to apply oil once a week in normal use, once in ten hours in continuous use.

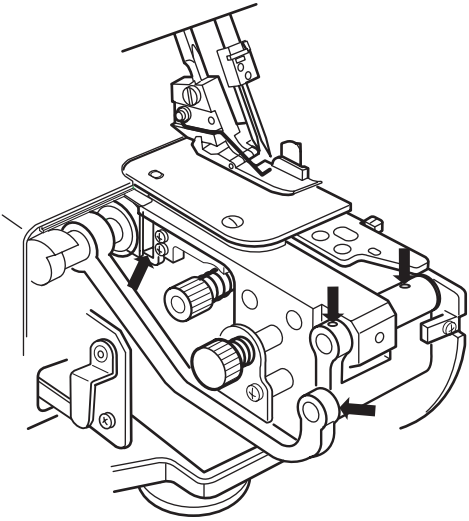

\* Open the side cover and apply oil.

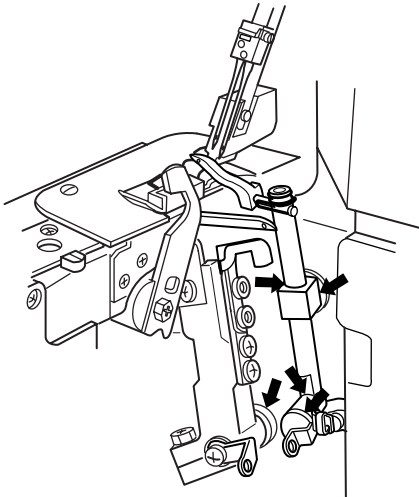

\* Open the looper cover and apply oil.

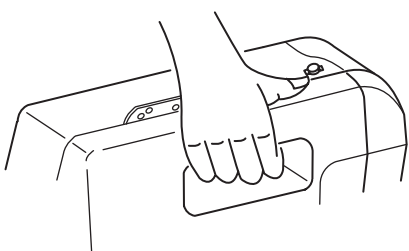

## Carrying the Machine

Put your fingers into the hole on the back side of the machine as illustrated.

## Troubleshooting

Condition	Cause	Reference
<b>The fabric is not being fed smoothly.</b>	<ol style="list-style-type: none"> <li>1. The feed dog is packed with lint.</li> <li>2. The presser foot has been raised.</li> <li>3. Pressure of the foot is too weak.</li> </ol>	<p>See page 76. Lower the presser foot. See page 18</p>
<b>The needle breaks.</b>	<ol style="list-style-type: none"> <li>1. The needle is incorrectly inserted.</li> <li>2. The needle is bent or blunt.</li> <li>3. The fabric is forcedly pulled.</li> </ol>	<p>See page 16. See page 16. Pull the fabric lightly.</p>
<b>The thread breaks.</b>	<ol style="list-style-type: none"> <li>1. The machine is not correctly threaded.</li> <li>2. The needle or looper thread tension is too tight.</li> <li>3. The needle is incorrectly inserted.</li> <li>4. The needle is bent or blunt.</li> </ol>	<p>See pages 28 ~ 46 and 56. See pages 52 ~ 54 and 58, 66. See page 16. See page 16.</p>
<b>Skipped stitches</b>	<ol style="list-style-type: none"> <li>1. The needle is bent or blunt.</li> <li>2. The machine is not correctly threaded.</li> <li>3. The needle is incorrectly inserted.</li> </ol>	<p>See page 16. See pages 28 ~ 46 and 56. See page 16.</p>
<b>The seam is not sewn neatly.</b>	<ol style="list-style-type: none"> <li>1. The needle and/or looper thread tensions are not correctly adjusted.</li> <li>2. The machine is not correctly threaded.</li> <li>3. The needle and/or the thread are not suitable for the fabric being sewn.</li> <li>4. The thread is not between the tension discs.</li> </ol>	<p>See pages 52 ~ 54 and 58, 66. See pages 28 ~ 46 and 56.  See pages 60, 62, 70 and 72. See pages 32, 38, 42 and 46.</p>
<b>Seam puckering.</b>	<ol style="list-style-type: none"> <li>1. The needle or looper thread tension is too tight.</li> <li>2. The machine is not correctly threaded.</li> <li>3. The differential feed dial is not correctly adjusted.</li> </ol>	<p>See pages 52 ~ 54 and 58, 66. See pages 28 ~ 46 and 56.  See page 20.</p>
<b>The machine does not operate.</b>	<ol style="list-style-type: none"> <li>1. The machine has not been plugged in firmly.</li> <li>2. The power switch is turned off.</li> </ol>	<p>See page 10. See page 10.</p>
<b>The fabric is not cut neatly.</b>	<ol style="list-style-type: none"> <li>1. The position of the upper knife is not adjusted properly.</li> <li>2. The upper knife is dull.</li> </ol>	<p>See page 74. Replace the upper knife. (See page 74.)</p>

## OPTIONAL PARTS

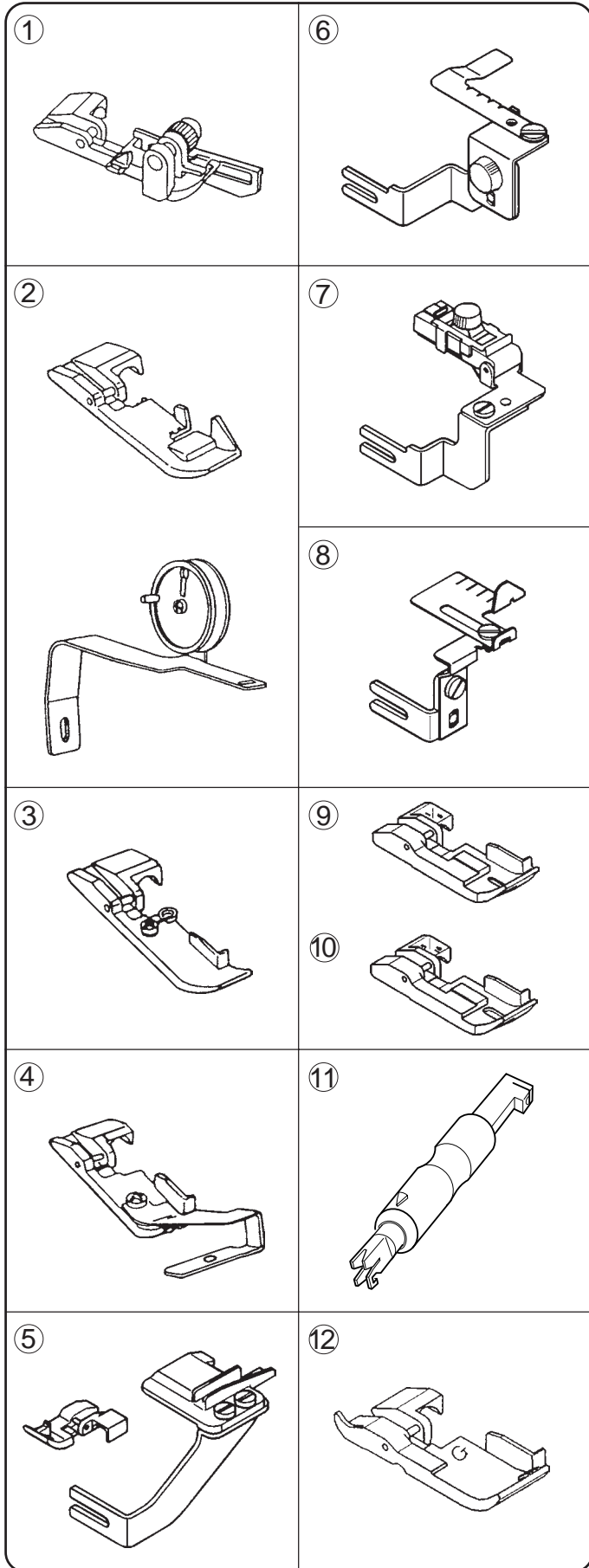

①	Blind stitch foot	Use to blind stitch a cuff or a skirt.
②	Taping foot with tape reel	Use for sewing tape on a shoulder or armpit line to protect from stretching or to decorate. Works well with the taping foot or the cording foot.
③	Cording foot (1)	Use to sew decorative cording.
④	Cording foot (2)	Use to sew decorative cording.
⑤	Beading attachment	Use for decorating cloth, wide cord decoration, cording, etc.
⑥	Gathering attachment	Use when sewing sleeves, cuffs, collars, etc.
⑦	Elastic gathering attachment	Use for elastic taping, decorative taping, etc.
⑧	Cloth guide	Use to help you create a constant-width seam allowance and when doing flat-lock and pintuck sewing.
⑨	Piping foot (1/8")	Use to pipe the edge of a sewing article to decorate or strengthen.
⑩	Piping foot (3/16")	
⑪	Needle threader	For easy threading and changing needle.
⑫	Gathering foot	Use to sew sleeves, yokes, frills, etc.

- ① 200-203-104
- ② 200-204-208
- ③ 200-207-108
- ④ 200-208-109
- ⑤ 200-214-108
- ⑥ 200-217-101
- ⑦ 200-218-102
- ⑧ 200-216-100
- ⑨ 200-219-103
- ⑩ 200-220-107
- ⑪ 200-254-605
- ⑫ 200-248-101