

Instruction Book



IMPORTANT SAFETY INSTRUCTIONS

This appliance can be used by children aged from 8 years and above and persons with reduced physical, sensory or mental capabilities or lack of experience and knowledge if they have been given supervision or instruction concerning use of the appliance in a safe way and understand the hazards involved. Children shall not play with the appliance. Cleaning and user maintenance shall not be made by children without supervision.

When using an electrical appliance, basic safety precautions should always be followed, including the following:

This sewing machine is designed and manufactured for household use only.

Read all instructions before using this sewing machine.

DANGER— To reduce the risk of electric shock:

1. An appliance should never be left unattended when plugged in. Always unplug this sewing machine from the electric outlet immediately after using and before cleaning.

WARNING— To reduce the risk of burns, fire, electric shock, or injury to persons:

1. Do not allow to be used as a toy. Close attention is necessary when this sewing machine is used by or near children.
2. Use this appliance only for its intended use as described in this owner's manual. Use only attachments recommended by the manufacturer as contained in this owner's manual.
3. Never operate this sewing machine if it has a damaged cord or plug, if it is not working properly, if it has been dropped or damaged, or dropped into water. Return this sewing machine to the nearest authorized dealer or service center for examination, repair, electrical or mechanical adjustment.
4. Never operate the appliance with any air opening blocked. Keep ventilation openings of this sewing machine and foot controller free from accumulation of lint, dust and loose cloth.
5. Never drop or insert any object into any opening.
6. Do not use outdoors.
7. Do not operate where aerosol (spray) products are being used or where oxygen is being administered.
8. To disconnect, turn all controls to the off ("O") position, then remove plug from outlet.
9. Do not unplug by pulling on cord. To unplug, grasp the plug, not the cord.
10. Keep fingers away from all moving parts. Special care is required around the sewing machine needle and/or cutting blade.
11. Always use the proper needle plate. The wrong plate can cause the needle to break.
12. Do not use bent needles.
13. Do not pull or push fabric while stitching. It may deflect the needle causing it to break.
14. Switch this sewing machine off ("O") when making any adjustment in the needle area, such as threading the needle, changing the needle, threading the bobbin or changing the presser foot, and the like.
15. Always unplug this sewing machine from the electrical outlet when removing covers, lubricating, or when making any other adjustments mentioned in this owner's manual.

SAVE THESE INSTRUCTIONS

The design and specifications are subject to change without a prior notice.



Please note that on disposal, this product must be safely recycled in accordance with relevant National legislation relating to electrical/electronic products. If in doubt please contact your retailer for guidance. (European Union only)

TABLE OF CONTENTS

GETTING READY TO SEW

Names of Parts.....	1-2
Embroidery unit case.....	2
Standard Accessories.....	3-4
Extension Table.....	5
Accessory Storage.....	5
Changeable Frame.....	5
Connecting the Power Supply.....	6
Controlling Sewing Speed.....	7
Speed control slider.....	7
Foot control.....	7
Machine Operating Buttons.....	8
Touch Panel Keys.....	9
Setting the Spool of Thread.....	10
Winding the Bobbin.....	10-12
Removing the bobbin.....	10
Winding the bobbin.....	11
Inserting the bobbin.....	12
Threading the Machine.....	13
Needle threader.....	14
Drawing up the Bobbin Thread.....	15
Replacing Needles.....	16
Replacing the Presser Foot.....	17
Replacing the Foot Holder.....	18
Replacing the Needle Plate.....	19
Raising and Lowering the Presser Foot.....	20
Knee lifter.....	20
Adjusting the Foot Pressure.....	21
Raising and Dropping the Feed Dog.....	21
Mode Selection.....	22

ORDINARY SEWING MODE

Ordinary Stitch Patterns.....	23-24
Function Keys in Ordinary Sewing Mode.....	25-26
Utility Stitches.....	27
Straight stitches.....	27
Starting to sew.....	27
Sewing from the edge of thick fabric.....	27
Changing sewing direction.....	27
Turning a square corner.....	27
Securing seams.....	28
Cutting threads.....	28
Using the seam guide lines.....	28
Variety of straight stitches.....	29-30
Zigzag stitches.....	30
Variety of overcasting stitches.....	31-32
Manual Stitch Settings.....	33-34
Cloth guide.....	35
Buttonholes and Specialty Stitches.....	36
B1 Sensor (Square) buttonhole.....	37-38
Manual settings.....	39
Using the Stabilizer Plate.....	40
B2 Automatic (square) buttonhole.....	41-42
Other buttonholes.....	43
Corded buttonhole.....	44
B7 Darning.....	45
B9 Eyelet.....	46
Decorative Stitches.....	47-48
Quilting(Q).....	49
S1-S12 Decorative satin stitches.....	50
Twin Needle Sewing.....	51
Programming a Pattern Combination.....	52
Editing a pattern combination.....	53
Startover key.....	54
Checking pattern combination length.....	54
Monogramming.....	55
Function keys.....	55
Manual thread tension.....	56
Individual thread tension.....	56
Unified thread tension.....	56
Spacing.....	56
Reducing the size of letters.....	56
Programming a monogram.....	57
Sewing Application.....	58
Seaming.....	59
Overedge.....	60
Blind hem.....	61
Shell tuck.....	62
Rolled hem.....	63
Zipper sewing.....	64-66

Gathering.....	67
Basting.....	67
Button sewing.....	68
Tacking.....	69
Applique.....	70
Patchwork.....	71
Quilting.....	72-74

CUSTOMIZING MACHINE SETTINGS

Common Setting Mode.....	75-78
Ordinary Sewing Setting Mode.....	79-81
Correcting Deformed Stitch Patterns.....	82

EMBROIDERY MODE

Embroidery Unit.....	83
Attaching the embroidery unit.....	83
Extending the carriage arm.....	84
Detaching the embroidery unit.....	85
Attaching the Embroidery Foot.....	86
Foot pressure.....	86
Attaching the Straight Stitch Needle Plate.....	87
Special Bobbin Holder for Embroidery.....	88
Embroidery Hoops.....	89
Stabilizers.....	90
Setting the Fabric in an Embroidery Hoop.....	91
Attaching the Embroidery Hoop to the Machine.....	92
Selecting Built-in Embroidery Designs.....	93
Monogramming.....	94
Function keys.....	95
Programming a monogram.....	96
2- Letter monogram.....	97
Editing a monogram.....	98
Ready to Sew Window.....	99-102
Starting to sew embroidery.....	103
Fringe designs.....	104
Applique designs.....	105-106
Editing Mode.....	107
Free Arm Hoop (optional item).....	113

CUSTOMIZING MACHINE SETTINGS

Embroidery mode settings.....	114-116
-------------------------------	---------

FILE MANAGEMENT

Saving and Opening a File.....	117
Saving a file.....	117
Creating a new folder.....	118
Opening the file.....	119
Viewing file names.....	119
Changing a name of the file or folder.....	120

CARE AND MAINTENANCE

Cleaning the Hook Area.....	121
Cleaning the Inside of the Thread Guide.....	122
Troubleshooting.....	123-124
STITCH CHART.....	125-127
DESIGN CHART.....	128-131

GETTING READY TO SEW

Names of Parts

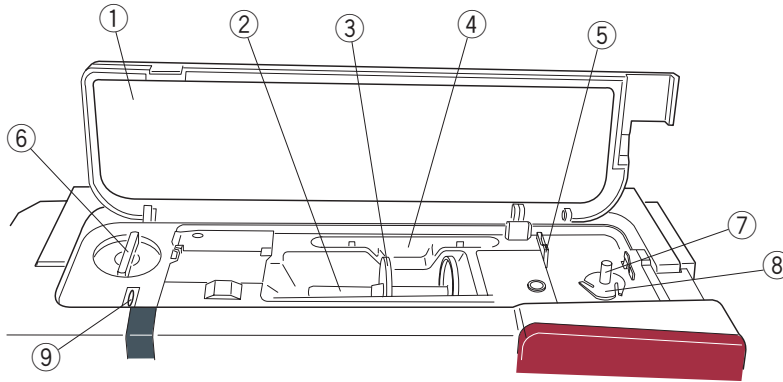

- ① Top cover
- ② Spool pin
- ③ Spool holder (Large)
- ④ Touch panel stylus holder
- ⑤ Bobbin thread cutter B
- ⑥ Presser foot pressure dial
- ⑦ Bobbin winder spindle
- ⑧ Bobbin thread cutter A
- ⑨ Thread take-up lever

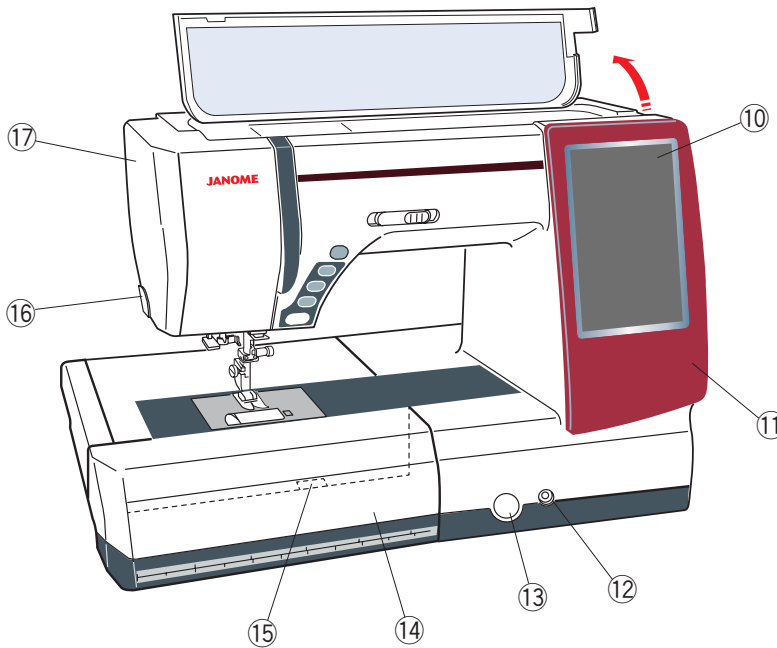

- ⑩ Visual touch screen
- ⑪ Changeable frame
- ⑫ Knee lifter socket
- ⑬ Feed balancing dial cap
- ⑭ Extension table (accessory storage)
- ⑮ Needle plate release lever
- ⑯ Thread cutter/holder
- ⑰ Face plate

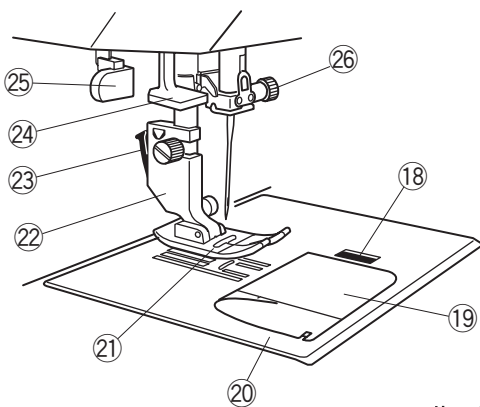

- ⑱ Hook cover release button
- ⑲ Hook cover plate
- ⑳ Needle plate
- ㉑ Zigzag foot A
- ㉒ Presser foot holder
- ㉓ Lever
- ㉔ Needle threader
- ㉕ Buttonhole lever
- ㉖ Needle clamp screw

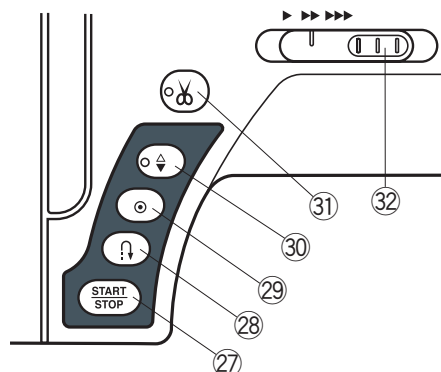

- ㉗ Start/stop button
- ㉘ Reverse button
- ㉙ Auto-lock button
- ㉚ Needle up/down button
- ㉛ Thread cutter button
- ㉜ Speed control slider

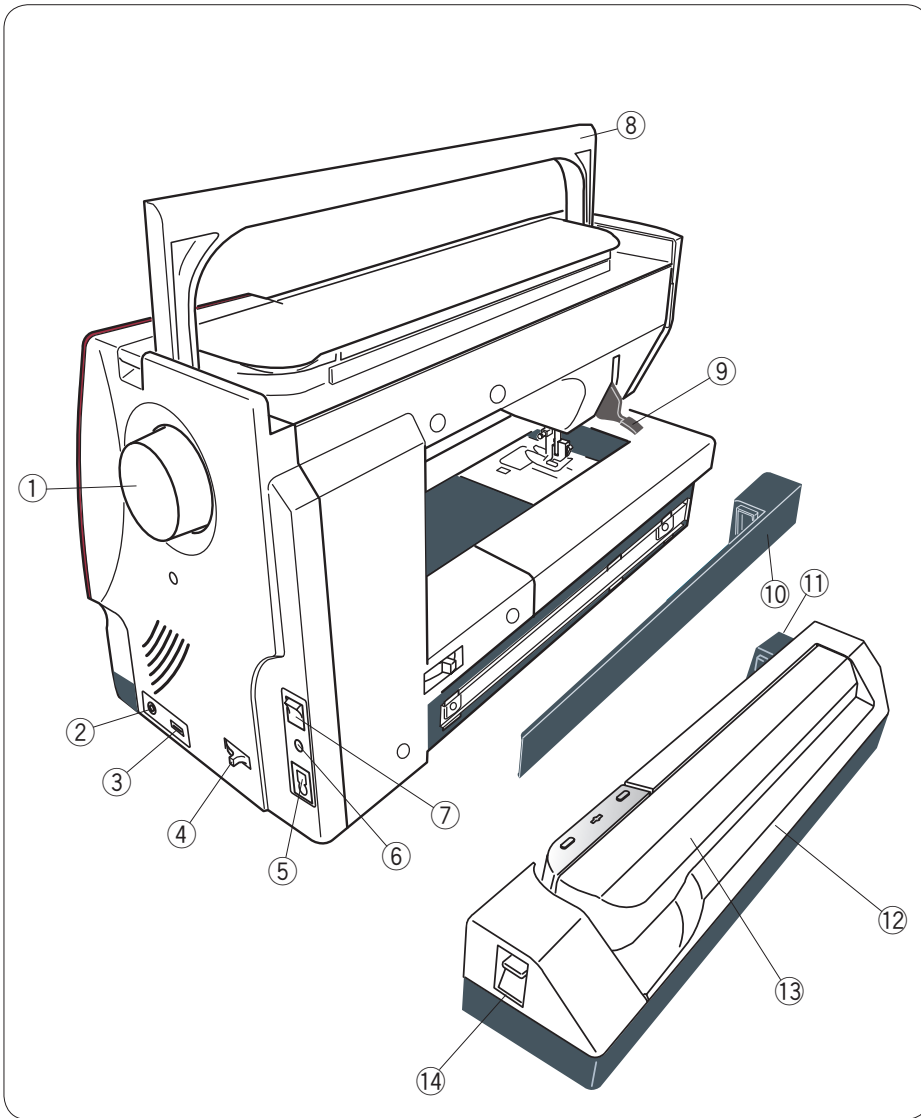

- ① Handwheel
- ② Connector for external thread cutter switch
- ③ USB port
- ④ Drop feed dog lever
- ⑤ Machine socket
- ⑥ Foot control jack
- ⑦ Power switch
- ⑧ Carrying handle
- ⑨ Presser foot lifter
- ⑩ Cover
- ⑪ Embroidery unit socket
- ⑫ Embroidery unit
- ⑬ Carriage arm
- ⑭ Carriage arm release lever

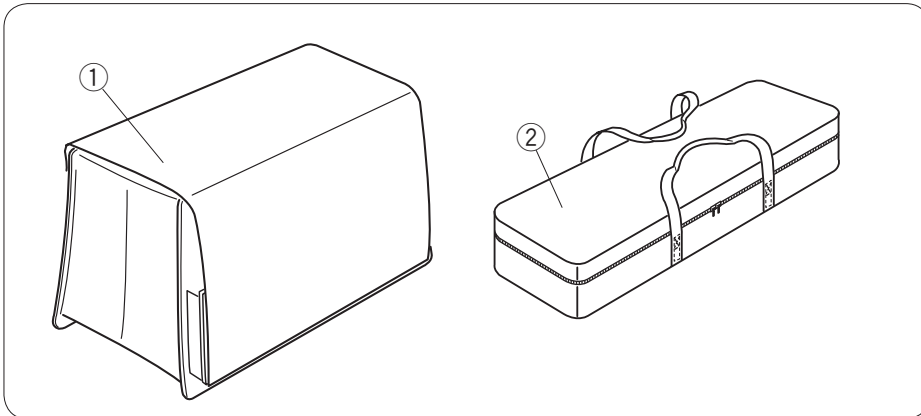

- ① Semi-hard fabric cover
- ② Embroidery unit case

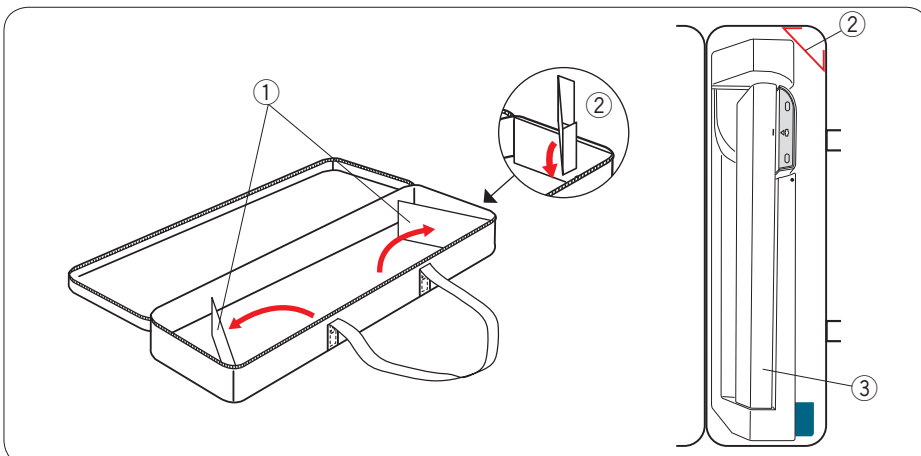

Embroidery unit case

To use:

Open the flaps.
 Attach the supporter as shown.
 Place the embroidery unit as shown
 so the supporter prevents the
 embroidery unit sways inside the
 case while carrying.

- ① Flaps
- ② Supporter
- ③ Embroidery unit

Standard Accessories

- ① Zigzag foot A (set on the machine)
- ② Overedge foot M
- ③ Satin stitch foot F
- ④ Blind hemming foot G
- ⑤ Zipper foot E
- ⑥ Automatic buttonhole foot R
- ⑦ Stabilizer plate
- ⑧ Rolled hem foot D
- ⑨ Darning foot PD-H
- ⑩ Button sewing foot T
- ⑪ 1/4" seam foot O
- ⑫ Embroidery foot P
- ⑬ Straight stitch needle plate
- ⑭ Bobbin X 5 (1 set on the machine)
- ⑮ Needle set
- ⑯ Screwdriver
- ⑰ Lint brush
- ⑱ Seam ripper (buttonhole opener)
- ⑲ Quilting guide bar
- ⑳ Spool holder X 2 (large) (1 set on the machine)
- ㉑ Spool holder X 2 (small)
- ㉒ Extra spool pin
- ㉓ Scissors
- ㉔ Button shank plate
- ㉕ Touch panel stylus
- ㉖ Bobbin holder cleaner
- ㉗ Changeable frame X2 (Metallic Green, Pearl White)
- ㉘ Cloth guide

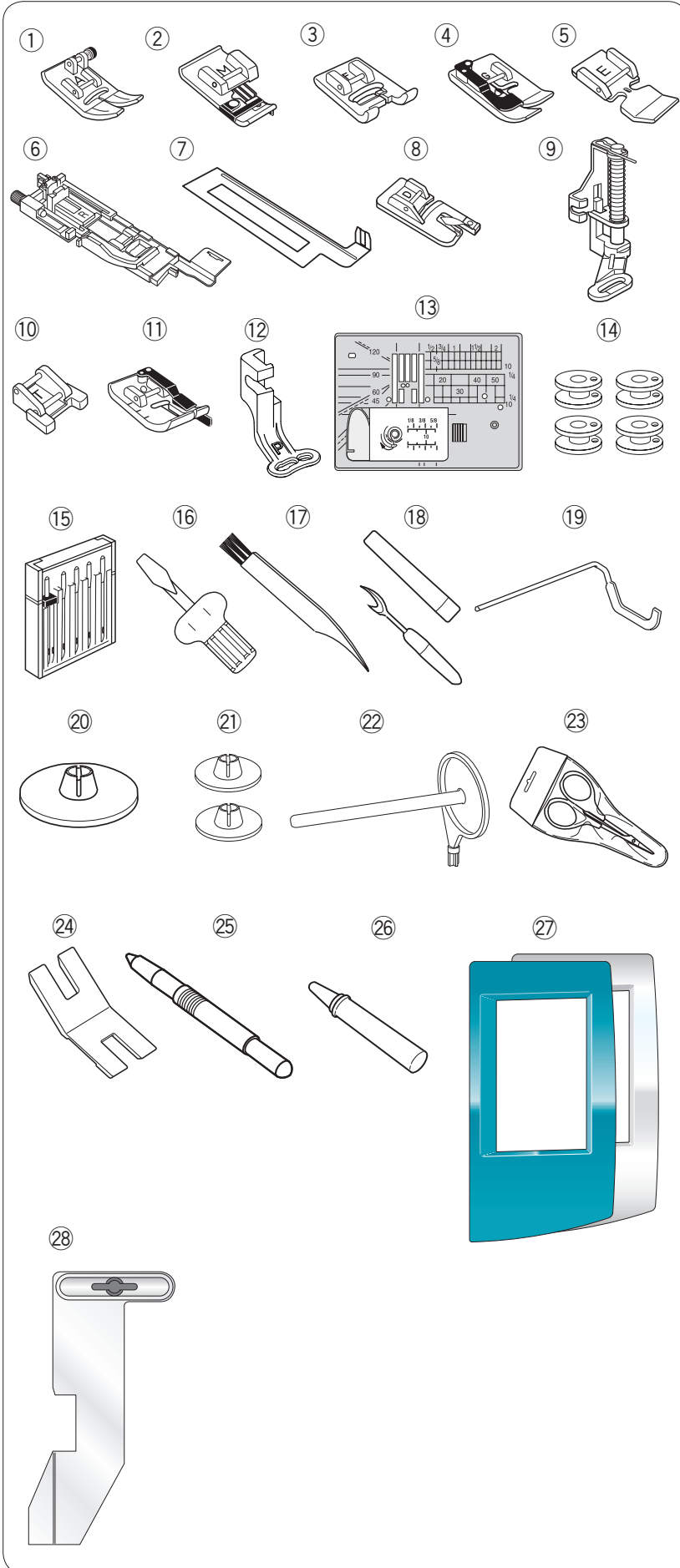

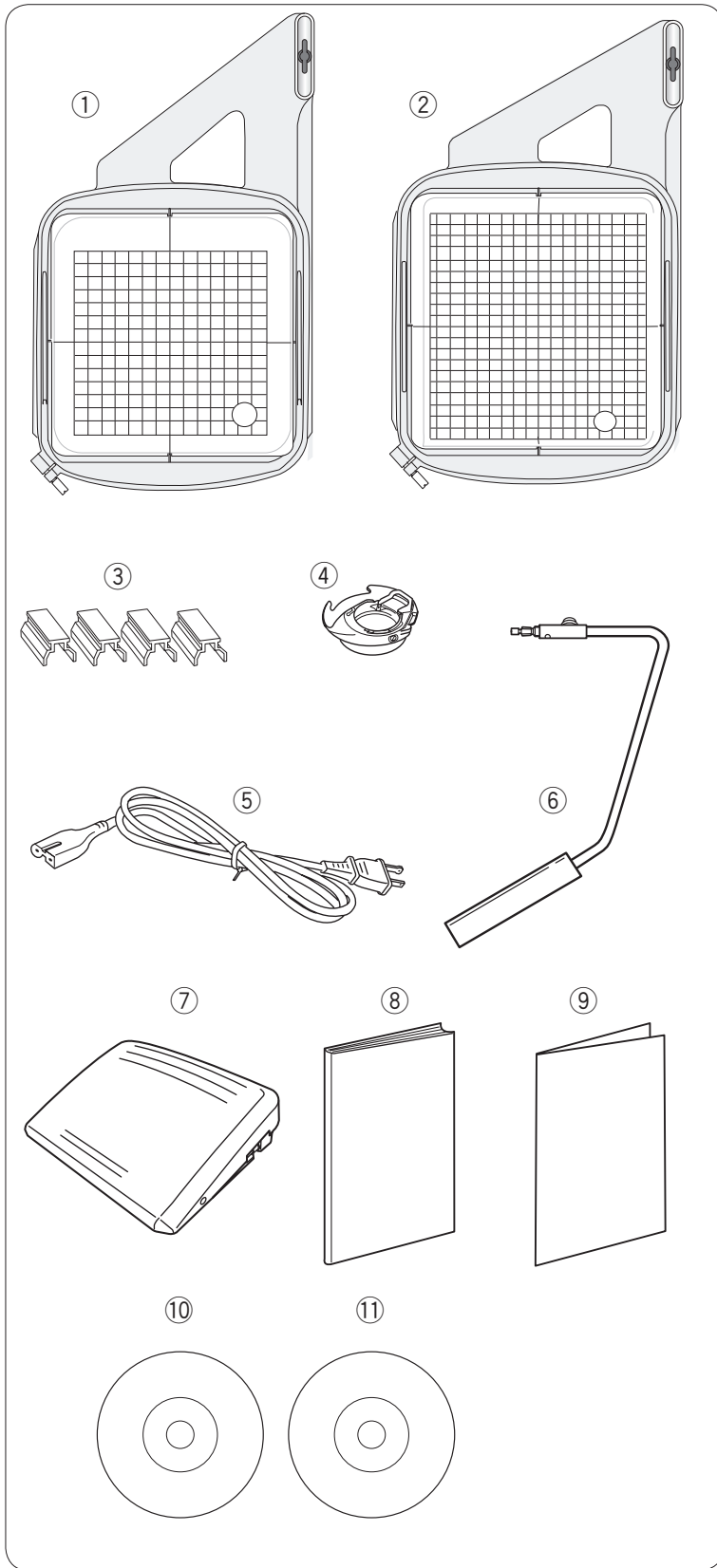

- ① Embroidery hoop SQ14a (with template)
- ② Embroidery hoop RE20a (with template)
- ③ Magnetic clamps (X4)
- ④ Bobbin holder for embroidery
- ⑤ Power supply cable
- ⑥ Knee lifter
- ⑦ Foot control
- ⑧ Instruction book
- ⑨ Key icon reference chart
- ⑩ Instructional DVD
- ⑪ Template CD

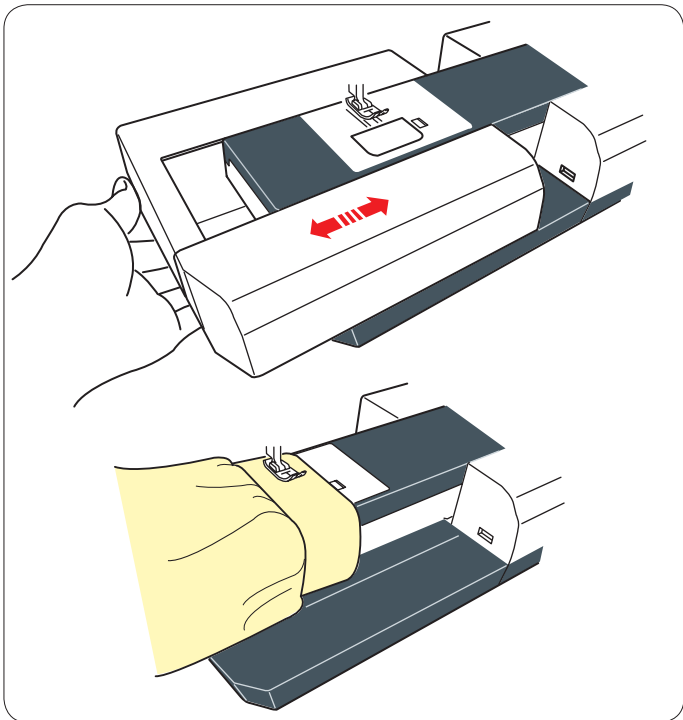

Extension Table

The extension table provides an extended sewing area and can be removed for free arm sewing.

To remove:

Draw the table to the left.

To attach:

Slide the table on the base and push it to the right.

Free arm sewing

The free arm is used for stitching sleeves, waistbands, pant legs or any other tubular garments. It is also useful for darning socks or elbows.

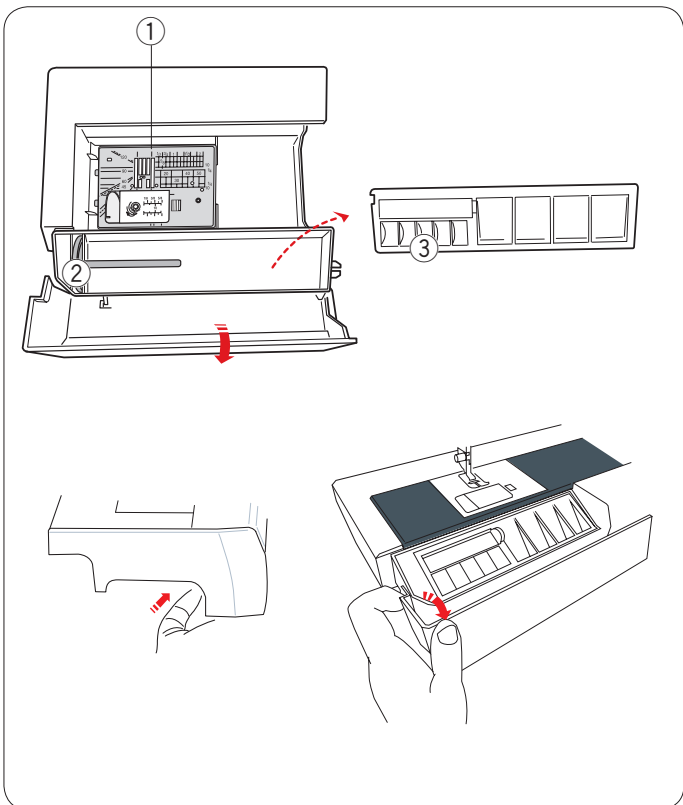

Accessory Storage

The accessories can be conveniently stored in the compartment in the extension table.

Pull the lid towards you to open the accessory storage.

- ① Straight stitch needle plate
- ② Extra spool pin
- ③ Bobbins

Other accessories can be stored in the compartment.

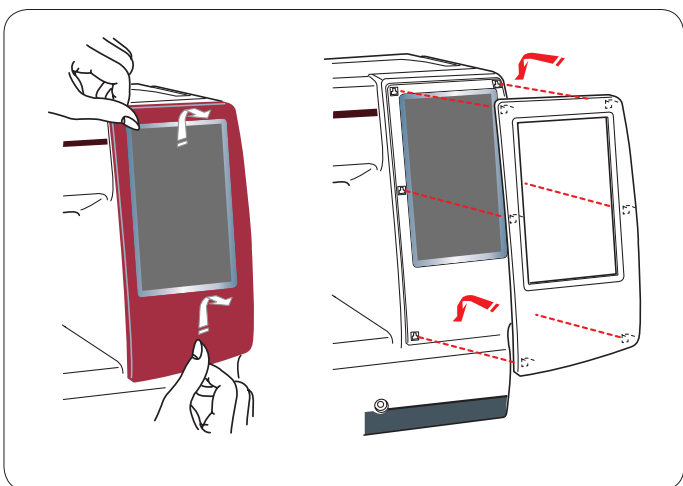

Changeable Frame

You can replace the changeable frame with the attached changeable frames (Pearl white or Metallic green).

To remove:

Hold the changeable frame with your hand, and slide the frame up.

Remove hooks from holes to remove the frame.

To attach:

Match the hooks to the holes.

Push the frame against the machine and slide it down along the machine to fit into the place.

Connecting the Power Supply

- 1 First make sure the power switch ① is off.
- 2 Insert the machine plug ② of the power supply cable into the machine socket ③.
- 3 Insert the power supply plug ④ into the wall outlet ⑤, and turn the power switch ① on.
 - ① Power switch
 - ② Machine plug
 - ③ Machine socket
 - ④ Power supply plug
 - ⑤ Wall outlet

NOTES:

Make sure to use the power supply cable that came with the machine.

If you turn off the power switch, wait for 5 seconds before turning it on again.



WARNING:

While in operation, always keep your eyes on the sewing area, and do not touch any moving parts such as the thread take-up lever, handwheel or needle.

Always turn off the power switch and unplug the machine from the power supply:

- when leaving the machine unattended.
- when attaching or removing parts.
- when cleaning the machine.

Do not place anything on the foot control.

If you wish to use the foot control, pull out the cord from the foot control and insert the pin connector into the jack on the machine.

- 1 First make sure the power switch ① is off.
- 2 Insert the machine plug ② of the power supply cable into the machine socket ③.
- 3 Draw out the cord from the foot control and insert the pin connector ④ into the jack ⑤ on the machine.
- 4 Insert the power supply plug ⑥ into the wall outlet ⑦, and turn the power switch ① on.
 - ① Power switch
 - ② Machine plug
 - ③ Machine socket
 - ④ Pin connector
 - ⑤ Jack
 - ⑥ Power supply plug
 - ⑦ Wall outlet

NOTE:

The start/stop button does not work when the foot control is connected.

Operating Instructions:

The symbol "O" on the switch indicates the "off" position of the switch.

For the U.S.A. and Canada only

Polarized plug (one blade wider than the other):

To reduce the risk of electric shock, this plug is intended to fit in a polarized outlet only one way. If it does not fit fully in the outlet, reverse the plug. If it still does not fit, contact a qualified electrician to install the proper outlet. Do not modify the plug in any way.

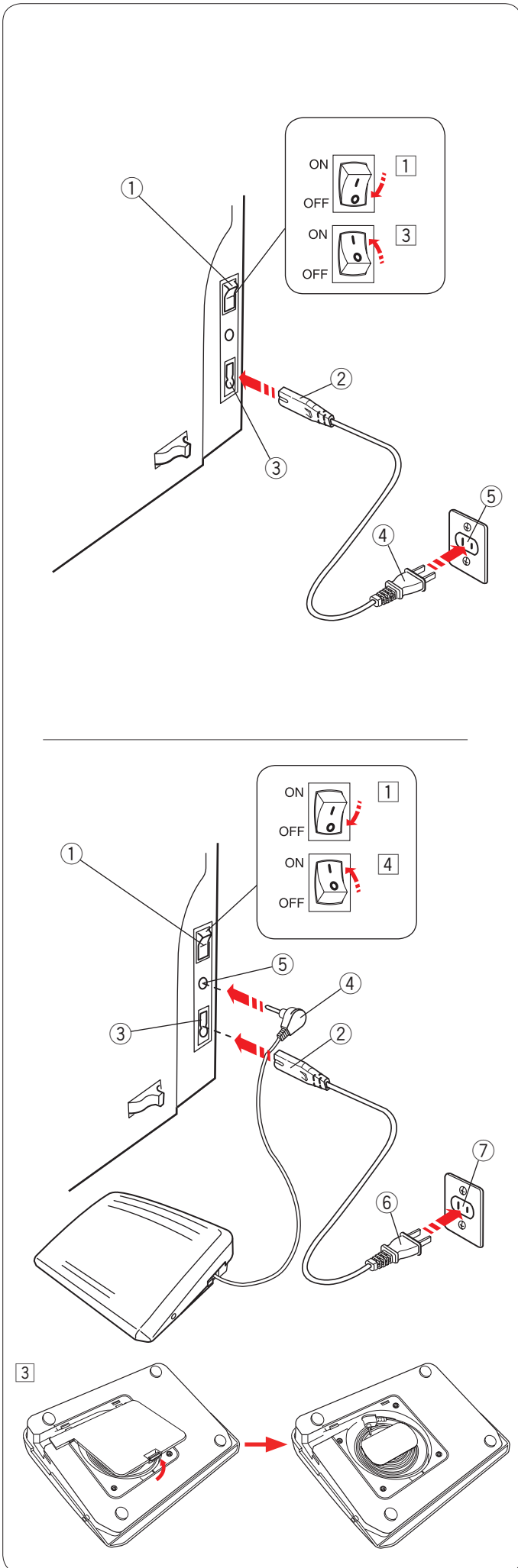

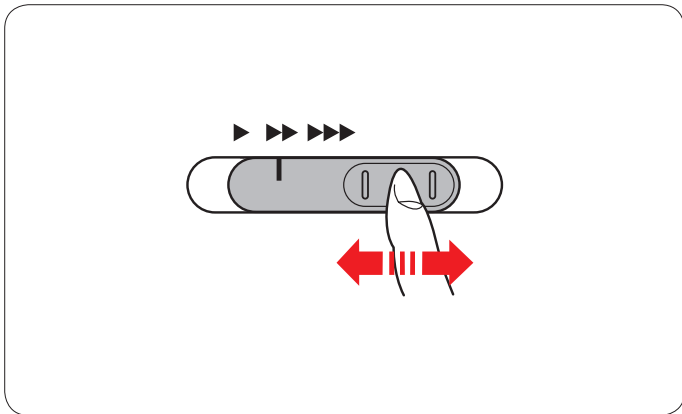

Controlling Sewing Speed

Speed control slider

You can limit the maximum sewing speed in both the ordinary sewing mode and embroidery mode with the speed control slider according to your sewing needs.

To increase the sewing speed, move the slider to the right.
To decrease the sewing speed, move the slider to the left.

The sewing speed can be changed while stitching.

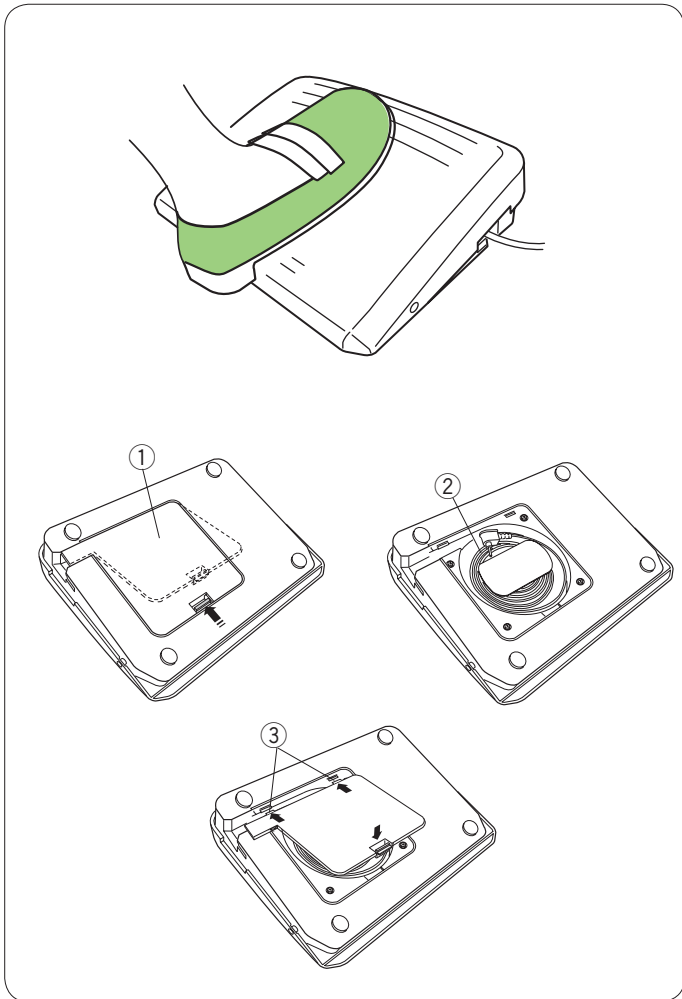

Foot control

Pressing on the foot control can vary sewing speed. The harder you press the foot control, the faster the machine runs.

NOTES:

The machine runs at the maximum speed set by the speed control slider when the foot control is fully depressed.

This machine is equipped with an automatic shutdown safety feature to prevent overheating whenever the machine is running overloaded. Follow the safety instructions that appear on the visual touch screen.

Cord storage

The cord of the foot control can be conveniently stored in the cord storage under the base cover of the foot control.

- ① Base cover
- ② Cord
- ③ Hooks

Operating Instructions:

Foot control model 21380 is for use with this sewing machine.

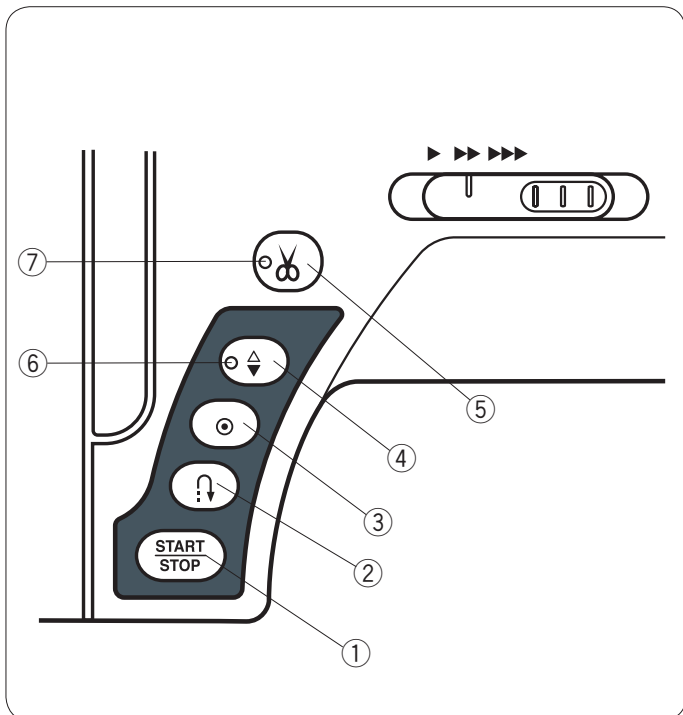

Machine Operating Buttons

① Start/stop button

Press this button to start or stop the machine.

The machine starts running slowly for the first few stitches, it then runs at the speed set by the speed control slider. The machine runs slowly as long as this button is pressed.

The button will turn red when the machine is running, and green when it has been stopped.

Pressing and holding this button while sewing will slow down the sewing speed and the machine will stop when the button is released.

NOTES:

- The start/stop button cannot be used when the foot control is connected to the machine.
- You can select the desired start-up speed from slow, normal or high (refer to page 79).

② Reverse button

When sewing stitch pattern U1, U4, U9, U10, Q1-Q3 or BR1-5, the machine will sew in reverse as long as the reverse button is pressed.

If stitch pattern U1, U4, U9, U10, Q1-Q3 or BR1-5, has been selected and the foot control is not connected, the machine will start sewing in reverse as long as the reverse button is pressed.

If you press the reverse button when sewing any other patterns, the machine will immediately sew locking stitches and automatically stop.

③ Auto-lock button

When sewing stitch pattern U1, U4, U9, U10, Q1-Q3 or BR1-5, the machine will immediately sew locking stitches and automatically stop when the auto-lock button is pressed.

When sewing all other patterns, the machine will sew to the end of the current pattern, sew locking stitches and stop automatically.

The machine will trim the threads automatically after locking the stitch when “Thread Cut after Auto-Lock” option is turned on (refer to page 81).

④ Needle up/down button

Press this button to bring the needle bar up or down.

The machine will stop with the needle in down position.

However, you can change the needle stop position in the setting mode (refer to page 79).

NOTE:

The LED signal ⑥ is turned on when the down position is selected and vice versa.

⑤ Thread cutter button

Press this button when you finish sewing to trim the threads. The needle bar automatically rises after trimming the threads (refer to page 28).

NOTES:

- The LED signal ⑦ blinks when the machine trims threads.
- The LED signal ⑦ turns on when “Thread Cut after Auto-Lock” is ON in setting mode (refer to page 81).
- Use the thread cutter on the face cover if the thread is #30 or thicker.

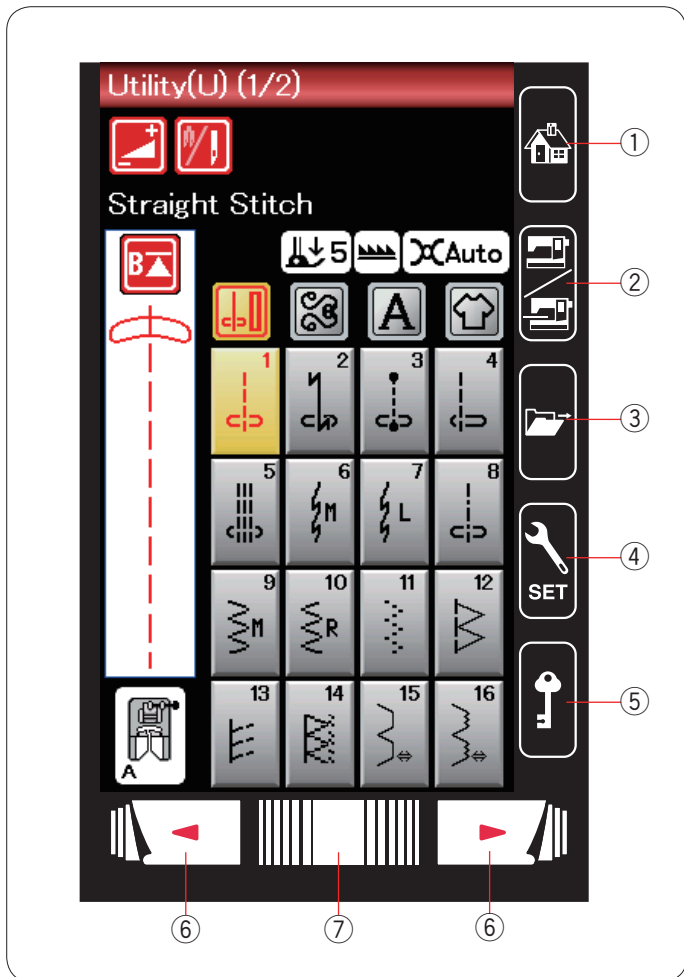

Touch Panel Keys

CAUTION:
Do not press the touch panel or visual touch screen with hard or sharp objects like pencils, screwdrivers or the like. Use the touch panel stylus included in the standard accessories.

- ① **Home key**
Press this key to return to the initial page of the ordinary sewing mode or embroidery mode.
- ② **Mode switch key**
Press this key to enter into embroidery mode or to return to ordinary sewing mode.
- ③ **Open file key**
Press this key and the open file window will open. You can open pattern combinations, monograms and embroidery designs saved in the machine's internal memory or on a USB flash drive.
- ④ **Set mode key**
Press this key to enter the setting mode. You can customize the machine settings to your preference. The machine settings for Common Settings, Ordinary Sewing, Embroidery and Choose Language are available in this mode (refer to page 75-81 and 114-116).
- ⑤ **Lockout key**
Press this key to lockout the machine when threading the machine, replacing the accessories etc. To reduce the risk of injury, all the buttons are deactivated. To unlock the machine, press this key again.
- ⑥ **Page keys**
Press the page key to display the next page or previous page. Press and hold the page key to turn the pages continuously.
- ⑦ **Touch bar**
Press on the bar and slide to the right or left to display the next page or previous page.

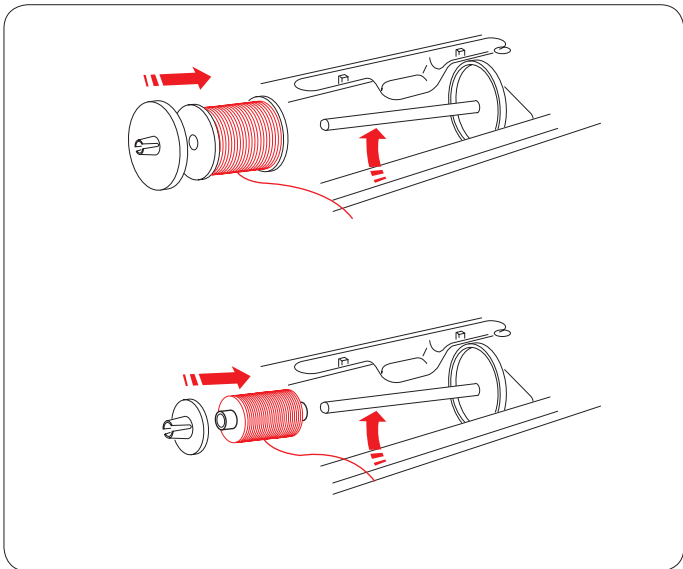

Setting the Spool of Thread

Open the top cover.

Lift up the spool pin. Place the spool of thread on the spool pin.

Attach the large spool holder, and press it firmly against the spool of thread.

NOTE:

Use the small spool holder to hold narrow or small spools of thread.

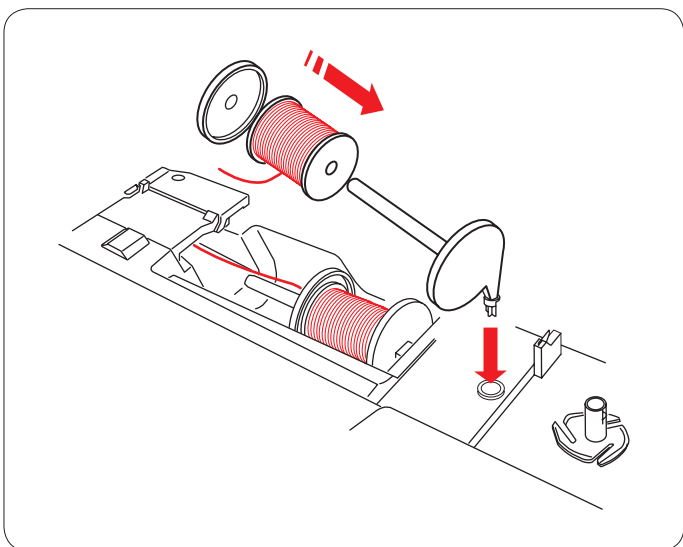

Extra spool pin

Use the extra spool pin when you need to wind the bobbin without unthreading the machine while working on a sewing project.

Insert the extra spool pin into the hole as shown.

Place a spool of thread on the extra spool pin and fix the spool with the spool holder.

NOTE:

The extra spool pin is also used for twin needle sewing.

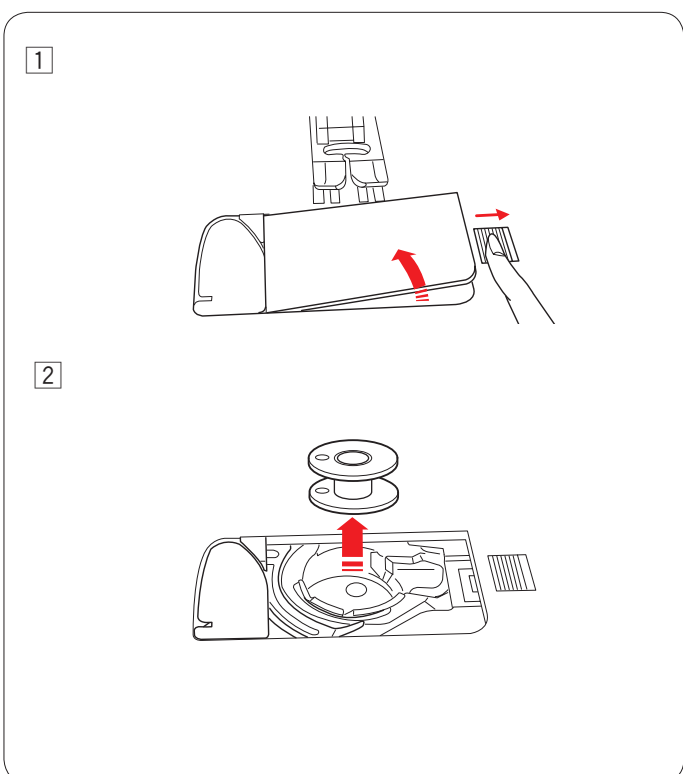

Winding the Bobbin

Removing the bobbin



CAUTION:

Press the lockout key or turn the power switch off.

- 1 Slide the hook cover release button to the right, and remove the hook cover plate.
- 2 Remove the bobbin from the bobbin holder.

NOTE:

Use the plastic bobbins (marked with a "J") for horizontal hook. Using other bobbins, such as pre-wound paper bobbins, may cause stitching problems and/or damage to the bobbin holder.

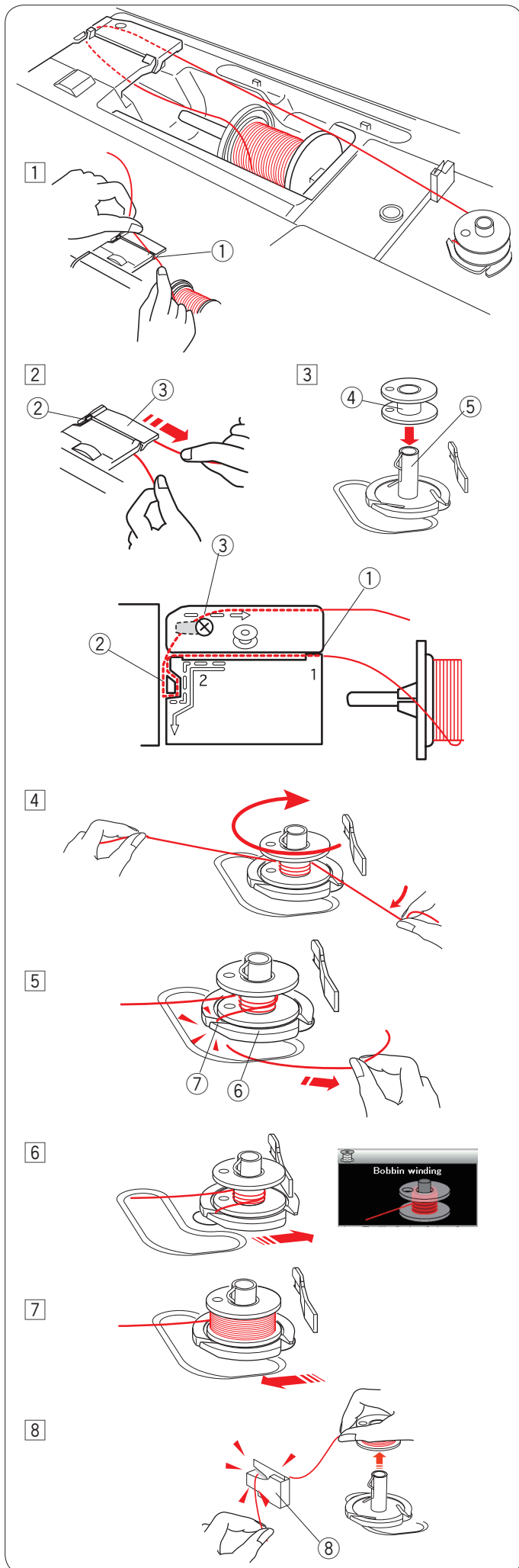

Winding the bobbin

- 1 Pull the thread from the spool.
Hold the thread with both hands and pass the thread into the guide slot ①.
① Guide slot

- 2 Draw the thread to the left and forward around the thread guide ②.
Draw the thread to the rear and to the right around and under the guide plate ③.
Firmly pull the thread to the right while holding it with both hands.
② Thread guide
③ Guide plate

- 3 Put the bobbin on the bobbin winder spindle.
④ Bobbin
⑤ Bobbin winder spindle

- 4 Pass the thread to the bobbin.
Hold the thread with both hands and wind it around the bobbin clockwise several times.

- 5 Insert the thread into one of the slits ⑦ of the flange plate ⑥ and pull the thread to cut.
⑥ Flange plate
⑦ Slit

- 6 Push the bobbin to the right. The visual touch screen will show the bobbin winding sign.

- 7 Start the machine. When the bobbin is fully wound, it will stop spinning automatically.
Stop the machine and return the bobbin winder to its original position by moving the spindle to the left.

- 8 Remove the bobbin. Cut the thread with bobbin thread cutter B.
⑧ Bobbin thread cutter B

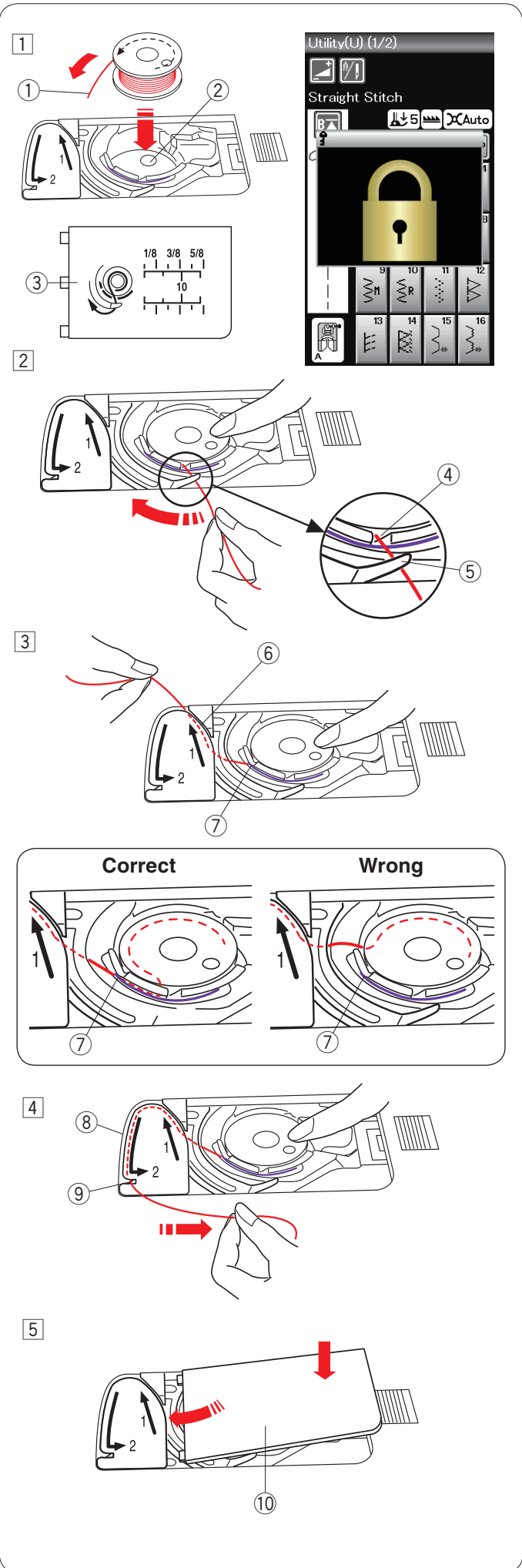

Inserting the bobbin

- 1 Press the lockout key.
Place a bobbin in the bobbin holder with the thread running off counterclockwise as shown on the hook cover plate.
 - ① End of thread
 - ② Bobbin holder
 - ③ Hook cover plate
- 2 Hold the bobbin with fingertip so it does not rotate. Guide the thread into the front notch of the bobbin holder. Pull the thread to the left to pass it under the guide.
 - ④ Front notch
 - ⑤ Guide
- 3 Draw the thread to the left to pass it into the guide path marked "1". Make sure that the thread comes out from the side notch of the bobbin holder.
 - ⑥ Guide path 1
 - ⑦ Side notch

NOTE:

If the thread does not come out from the side notch, rethread from step 1.

- 4 Continue to draw the thread along the guide path marked "2" and pull the thread to the right through the slit. The thread will be cut to a proper length and held in place.
 - ⑧ Guide path 2
 - ⑨ Slit (Thread cutter)
- 5 Set the left edge of the hook cover plate into opening. Push down the hook cover plate to fit in place.
 - ⑩ Hook cover plate

NOTE:

Unless otherwise noted, you can start sewing without drawing up the bobbin thread. Refer to page 15 for how to draw up the bobbin thread.

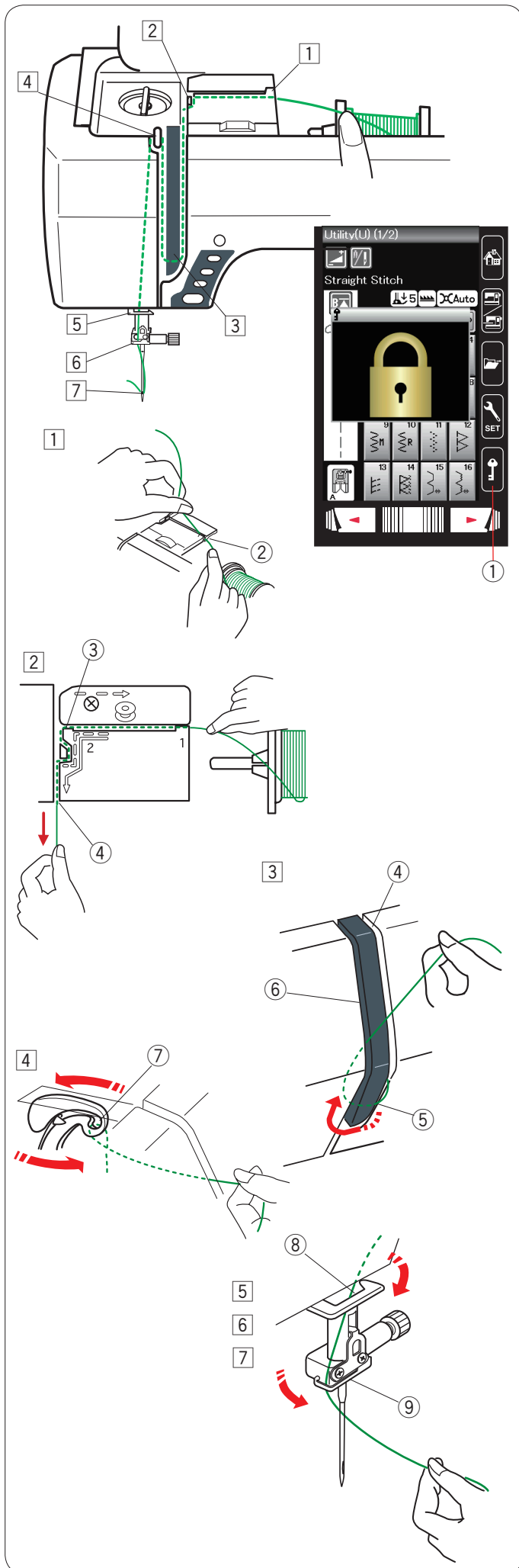

Threading the Machine

Press the needle up/down button to raise the take-up lever to the highest position.

Press the lockout key to lockout the machine. Raise the presser foot.

- ① Lockout key

Pass the thread in order from ① to ⑦.

- ① Hold the thread with both hands and pass the thread into the guide slot.
 - ② Guide slot
- ② Hold the thread with both hands and draw the thread around the corner of the guide. Firmly pull the thread toward you along the right channel until the thread snaps.
 - ③ Corner of the guide
 - ④ Right channel
- ③ Draw the thread down along the right channel and around the bottom of the thread guide plate. Pull the thread up along the left channel.
 - ④ Right channel
 - ⑤ Thread guide plate
 - ⑥ Left channel
- ④ While holding the thread at the spool, firmly draw the thread up and to the back of the take-up lever. Draw the thread forward to draw it into the eye of the take-up lever.
 - ⑦ Eye of the take-up lever
- ⑤ Then pull the thread down along the left channel and through the lower thread guide.
 - ⑧ Lower thread guide
- ⑥ Slide the thread behind the needle bar thread guide from the left.
 - ⑨ Needle bar thread guide
- ⑦ Thread the needle with the needle threader (refer to the next page).

Needle threader

NOTE:

The needle threader can be used with a #11 to #16 needle.

Thread size 50 to 90 is recommended.

Make sure the machine is locked out.

Lower the presser foot.

1 Pull down the needle threader knob as far as it will go. The threader hook comes out through the needle eye from behind.

1 Threader knob

2 Threader hook

2 Draw the thread from the left to the right, under the left guide, threader hook and right guide.

Draw the thread around the right guide toward you.

3 Left guide

4 Right guide

3 Raise the threader slowly so a loop of the thread is pulled up through the needle eye.

5 Thread loop

4 Pull the thread loop to take the thread end out through the needle eye to the rear.

Press the lockout key to unlock the machine.

NOTE:

The needle threader cannot be used with a twin needle.

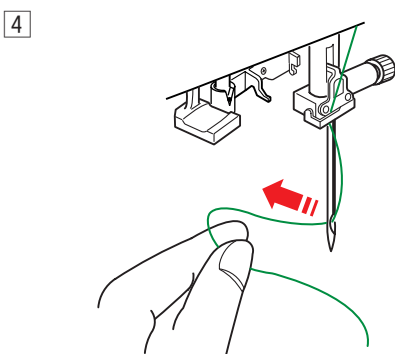
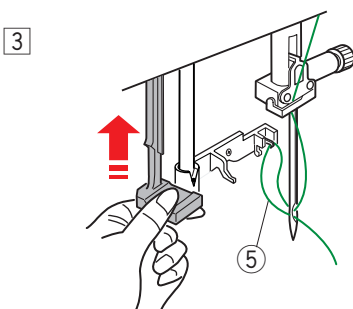
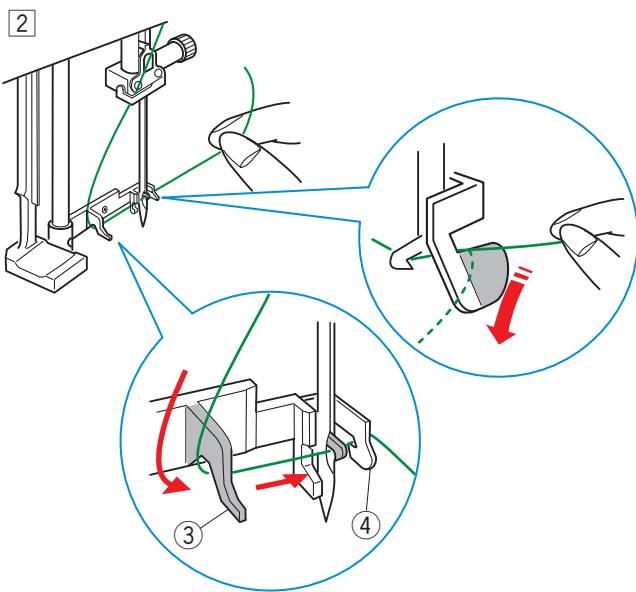
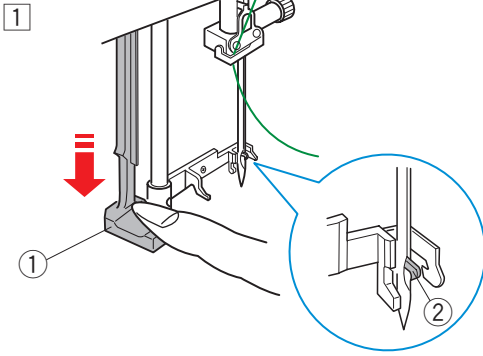

Drawing up the Bobbin Thread

After using auto thread cutting or threading the bobbin holder, you can start sewing without drawing up the bobbin thread.

However, you need to draw up the bobbin thread when sewing gathering stitches etc.

- 1 Remove the bobbin. Insert the bobbin into the bobbin holder again and rethread the bobbin holder according to the instructions on page 12, but leave a 10 cm (4") tail of bobbin thread as shown.

① Bobbin thread

NOTE:

Do not cut the bobbin thread with the thread cutter.

② Thread cutter

- 2 Raise the presser foot. Hold the needle thread lightly with your left hand.

③ Needle thread

- 3 Press the needle up/down button twice to lower and raise the needle to pick up the bobbin thread.

④ Needle up/down button

- 4 Pull both threads 10 cm (4") under and behind the presser foot.

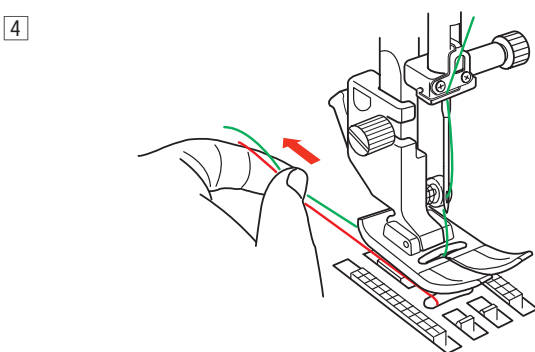
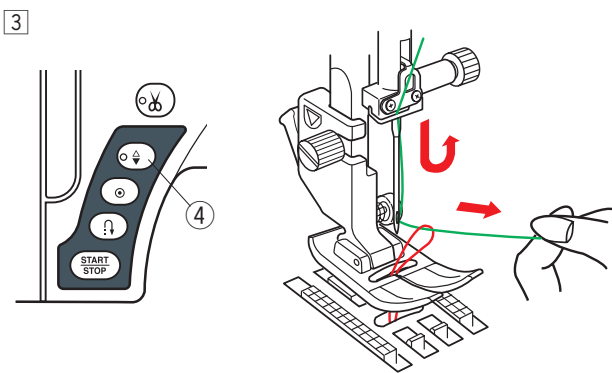
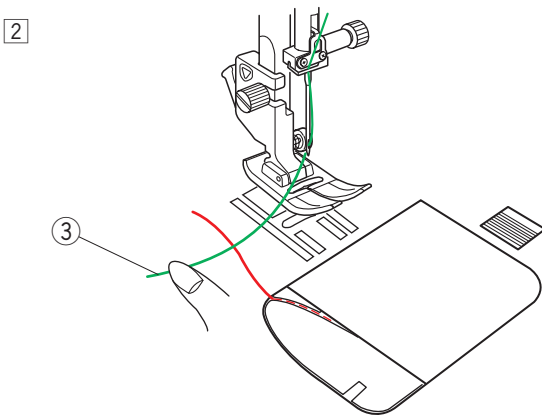
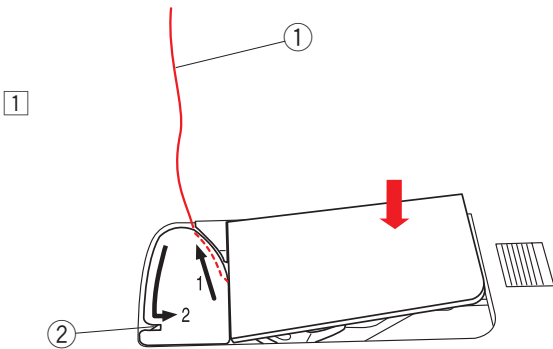

Replacing Needles

CAUTION:

Always make sure to press the lockout key to lockout the machine or turn the power switch off before replacing the needle.

Raise the needle by pressing the needle up/down button. Press the lockout key.

① Lockout key

Loosen the needle clamp screw by turning it counter-clockwise.

Remove the needle from the clamp.

② Needle clamp screw

Insert a new needle into the needle clamp with the flat side of the needle to the rear.

③ Flat side

When inserting the needle into the needle clamp, push it up against the stopper pin and tighten the needle clamp screw firmly with a screwdriver.

To check needle straightness, place the flat side of the needle onto something flat (a needle plate, glass etc.) The gap between the needle and the flat surface should be consistent.

④ Gap

Never use a blunt needle.

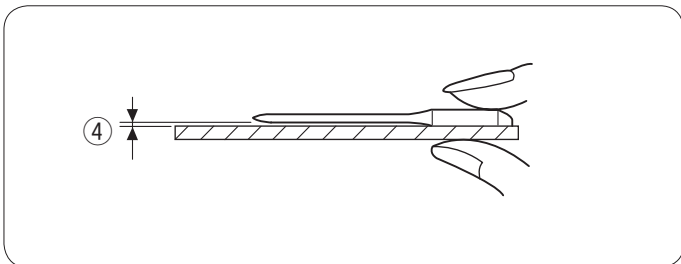
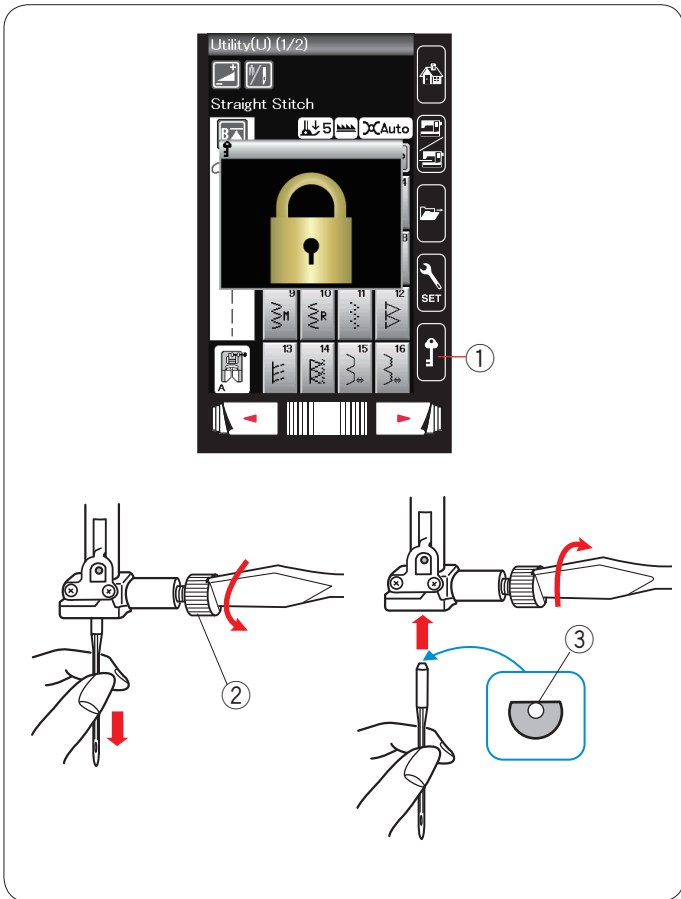

Fabric		Thread	Needle
Fine	Lawn	Silk #80-100	#9/65-11/75 Blue tip needle
	Georgette	Cotton #80-100	
	Tricot	Synthetic #80-100	
Medium	Sheeting	Silk #50	#11/75-14/90 Red tip needle
	Jersey	Cotton #50-80	
	Wool Knit	Synthetic #50-80	
Heavy weight	Denim	Silk #30-50	#14/90-16/100 Purple tip needle
	Tweed	Cotton #40-50	
	Coating	Synthetic #40-50	
	Quilting		

Fabric and Needle Chart

- For general sewing, use needle size #11/75 or #14/90.
- Fine threads and needles should be used for sewing fine fabrics.
- In general, use the same thread for both needle and bobbin.
- Use a blue tip needle for sewing fine fabrics, stretch fabrics and buttonholes to prevent skipped stitches.
- Use a purple tip needle for sewing thick fabrics, denims, quilt layers and across the hem to prevent skipped stitches.
- Use a stabilizer or interface for stretch or fine fabrics to prevent seam puckering.
- Always test the thread and needle size on a small piece of the same fabric you will use for actual sewing.

NOTE:

1 x twin needle, 2 x blue tip needle (#11/75), 1 x red tip needle (#14/90) and 1 x purple tip needle (#14/90) are included in the needle case.

For embroidery:

- In general, use a blue tip needle.
- Use a red tip needle for dense stitch embroidery.

Replacing the Presser Foot

CAUTION:

Always make sure to press the lockout key to lockout the machine or turn the power switch off before replacing the presser foot.

Raise the needle by pressing the needle up/down button.
Press the lockout key.

- ① Lockout key

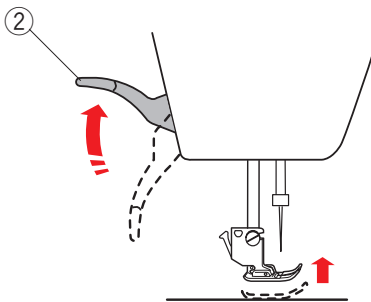
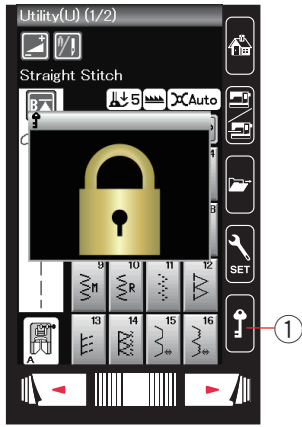

Raise the presser foot lifter.

- ② Presser foot lifter

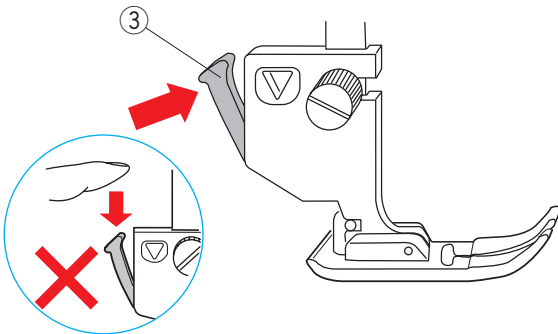

Press the black lever on the backside of the foot holder.
The presser foot will snap off.

- ③ Lever

CAUTION

To avoid damaging the lever, do not push it down.

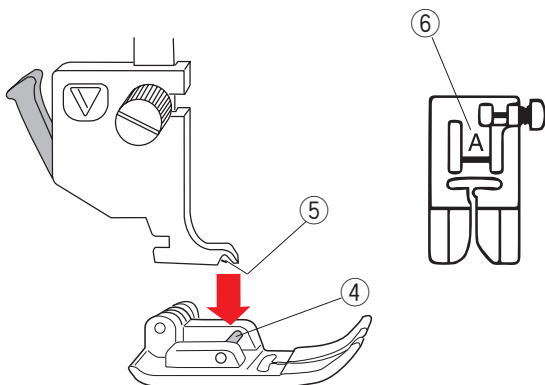

Place the desired foot under the foot holder so that the pin of the foot lies just under the groove of the foot holder.
Lower the presser foot lifter to lock the foot in place.

- ④ Pin
- ⑤ Groove

Each foot is marked with an identification letter.

- ⑥ Identification letter

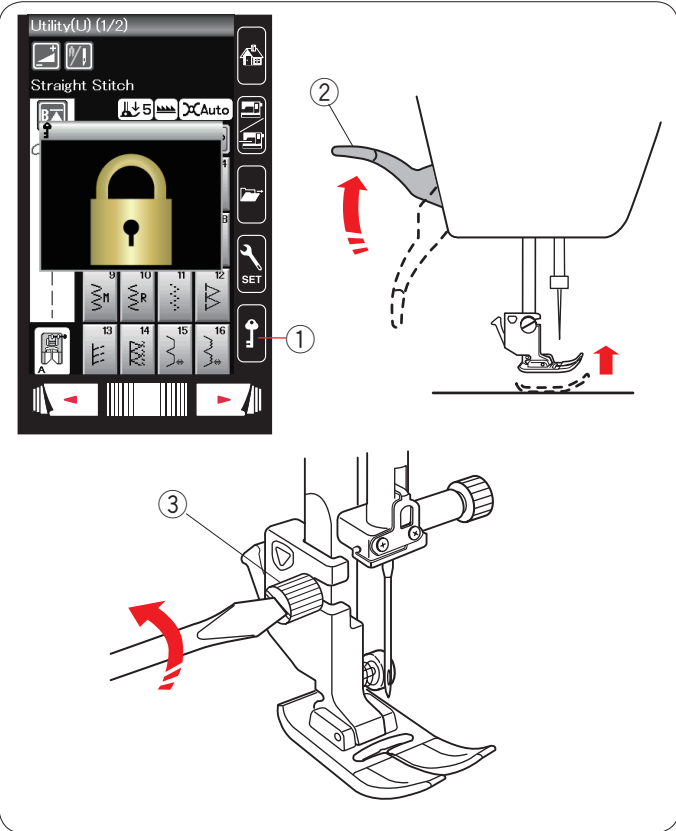

Replacing the Foot Holder

Replace the foot holder, if you use the darning foot or embroidery foot.

CAUTION:

Press the lockout key to lockout the machine or turn the power switch off before replacing the foot holder.

Removing the presser foot holder

Raise the needle by pressing the needle up/down button. Press the lockout key and raise the presser foot with the presser foot lifter.

- ① Lockout key
- ② Presser foot lifter

Loosen the thumbscrew and remove the presser foot holder.

- ③ Thumbscrew

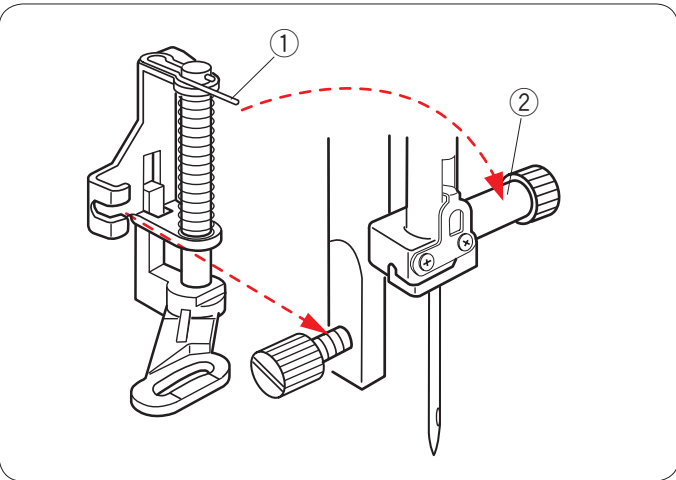

Attaching the darning foot PD-H

Attach the darning foot PD-H to the presser bar by putting the pin on the needle clamp screw.

- ① Pin
- ② Needle clamp screw

Tighten the thumbscrew firmly with the screwdriver.

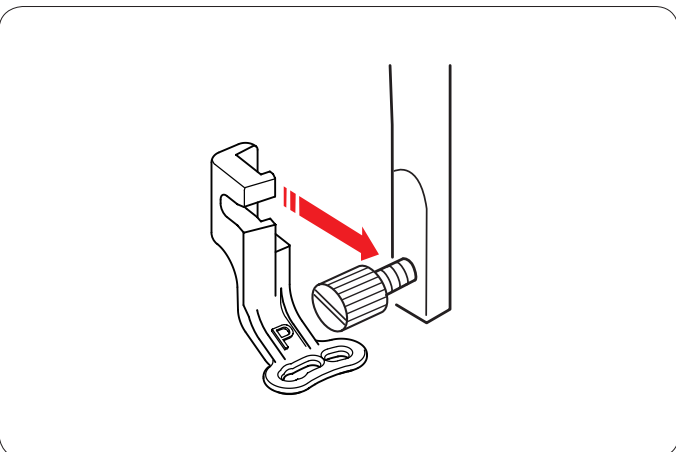

Attaching the embroidery foot P

Attach the embroidery foot P to the presser bar from behind.

Tighten the thumbscrew firmly with the screwdriver.

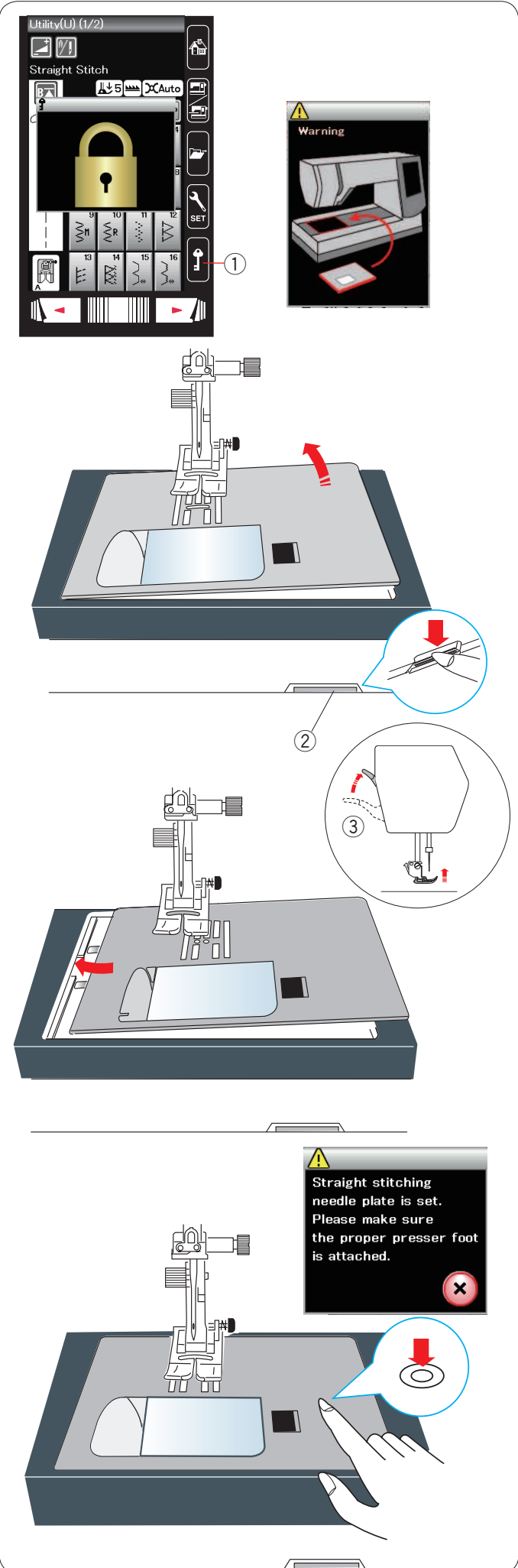

Replacing the Needle Plate

Use the straight stitch needle plate when sewing fine fabrics and also when embroidering.



CAUTION:

Always make sure to press the lockout key to lockout the machine before replacing the needle plate.

Raise the needle and press the lockout key.

Raise the presser foot lifter to raise the presser foot.

① Lockout key

Slide the extension table to the left to remove it.

Push down the needle plate release lever and the needle plate will snap off.

② Needle plate release lever

A message will appear warning that the needle plate is not secured.

Raise the presser foot lifter to the extra lifted position.

Remove the needle plate to the right.

③ Extra lifted position

Raise the presser foot lifter to the extra lifted position.

Place the straight stitch needle plate on the machine.

Set the left edge of the needle plate into the opening.

Push down on the mark of the needle plate until it locks in place.

A confirmation message will appear.

Press the X key and the straight stitch is automatically selected.

Turn the hand wheel slowly and make sure that the needle does not hit the needle plate.

Press the lockout key to unlock.



CAUTION:

Never press the needle plate release lever while running the machine.

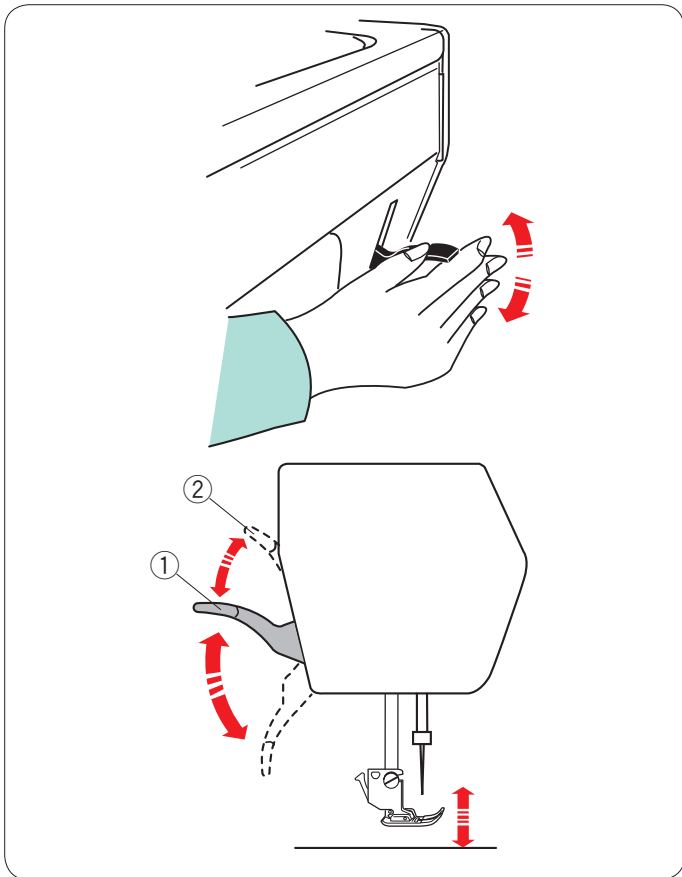

Raising and Lowering the Presser Foot

The presser foot lifter raises and lowers the presser foot.

- ① Presser foot lifter

You can raise the presser foot higher than the normal up position. This allows for changing the needle plate, and also helps you to place thick layers of fabrics under the foot.

- ② Extra lifted position

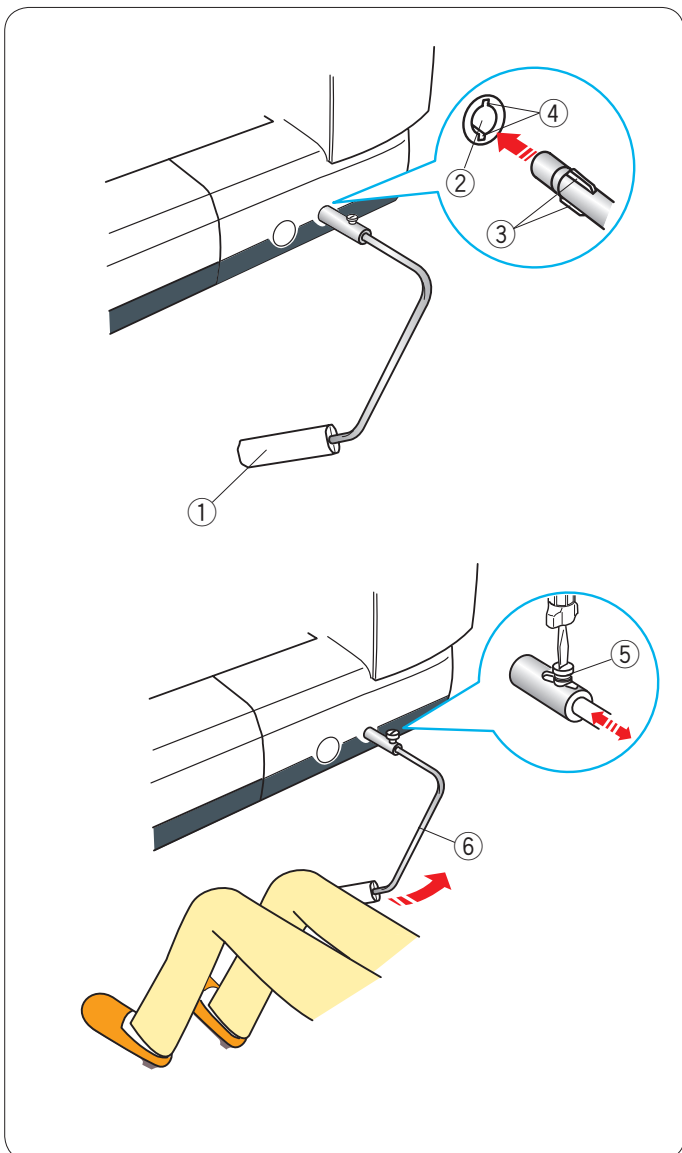

Knee lifter

The knee lifter is extremely helpful when sewing patchwork, quilting etc., since it allows you to handle the fabric while your knee controls the presser foot.

Attaching the knee lifter

Match the ribs on the knee lifter with the notches in the knee lifter socket and insert the knee lifter.

- ① Knee lifter
- ② Knee lifter socket
- ③ Rib
- ④ Notch

Adjusting the knee lifter

The angle of knee lifter can be adjusted to fit your knee. Loosen the setscrew and slide the angle bar in or out to adjust the angle of the knee lifter.

Tighten the setscrew to secure the angle bar.

- ⑤ Setscrew
- ⑥ Angle bar

Using the knee lifter

Push the knee lifter with your knee to move the presser foot up and down.

You can control how high the foot rises by the amount of knee pressure you exert.

NOTE:

Do not touch the knee lifter while stitching, otherwise the fabric will not be fed smoothly.

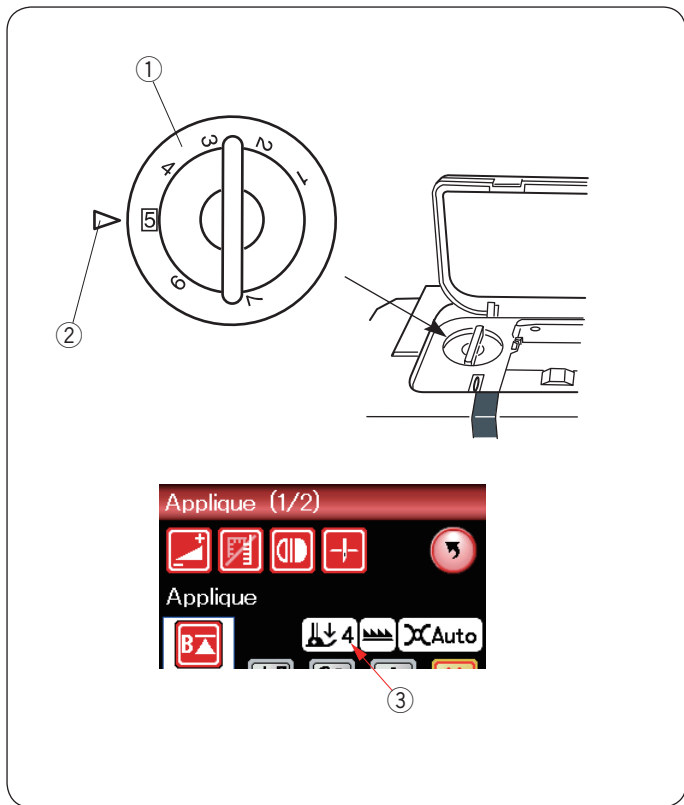

Adjusting the Foot Pressure

The foot pressure can be adjusted with the foot pressure dial located under the top cover.

The dial has 7 setting positions from 1 to 7. For ordinary sewing, set 5 at the setting mark.

- ① Foot pressure dial
- ② Setting mark
- ③ Recommended setting

Reduce the pressure when sewing fine synthetics and stretch fabrics.

To reduce the pressure, set the dial at a lower number.

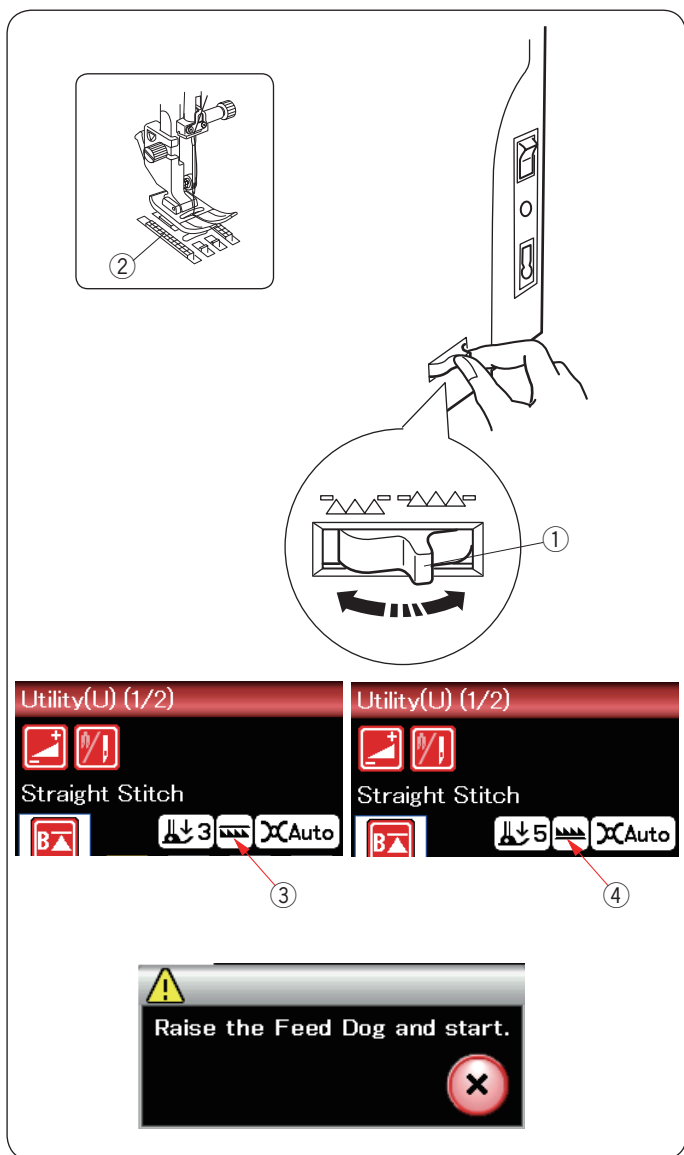

Raising and Dropping the Feed Dog

The feed dog can be lowered for basting, sewing on buttons, free motion quilting etc.

Shift the drop feed lever toward you to lower the feed dog.

- ① Drop feed lever
- ② Feed dog

Shift the drop feed lever away from you to raise the feed dog, it will return to the up position when you start the machine.

The feed dog position will be show on the visual touch screen.

- ③ Dropped position
- ④ Raised position

NOTE:
If you start the machine with the feed dog lowered, a message will appear on the visual touch screen.

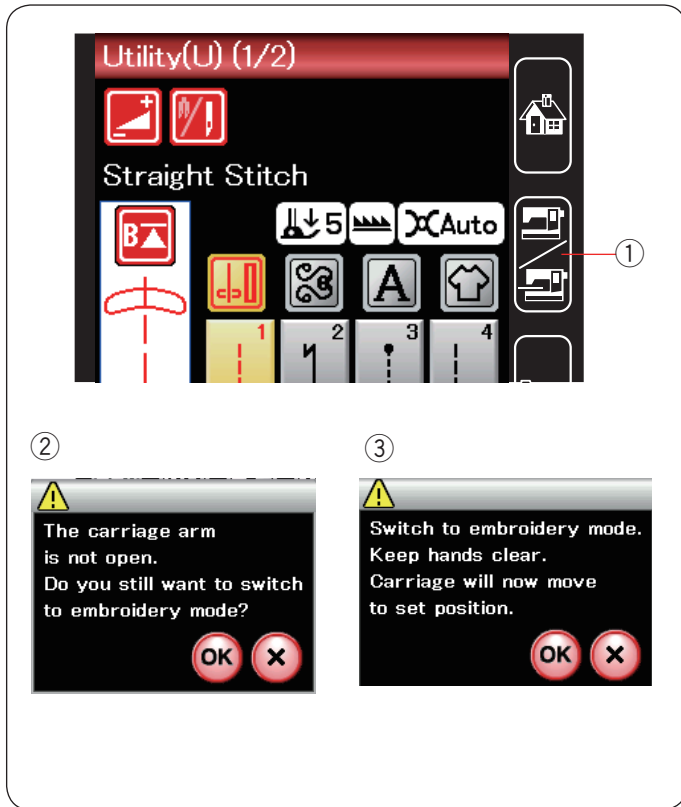

Mode Selection

When you turn the power switch on, the visual touch screen will show the ordinary sewing mode after a few seconds.

The machine is set for straight stitch sewing.

NOTE:

After turning on the power, it takes several seconds to display the opening window.
(This is the required boot up procedure.)

To switch to the embroidery mode, first turn the power switch off then attach the embroidery unit.

Turn the power switch on and press the mode switch key.

① Mode switch key

A confirmation message ② will appear. Do not press the OK key or X key. Open the carriage arm and the message ③ will appear. Press the OK key to switch to the embroidery mode and the carriage will move to the starting position.

To switch back to the ordinary sewing mode, press the mode switch key and follow the instructions in the confirmation message.

For embroidery sewing, please refer to embroidery sewing instruction from page 83.

①

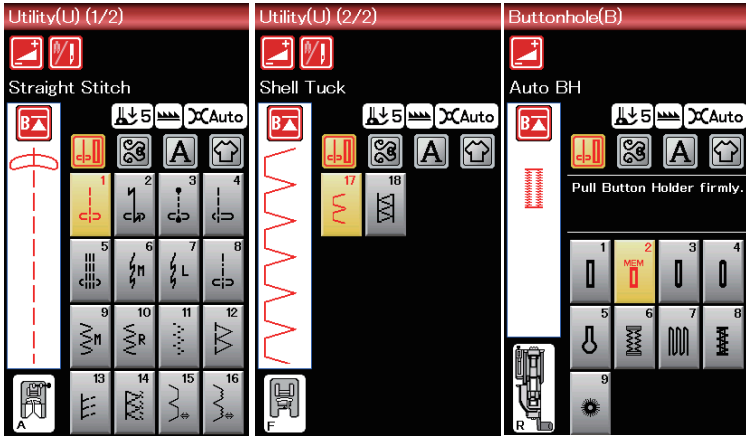

②

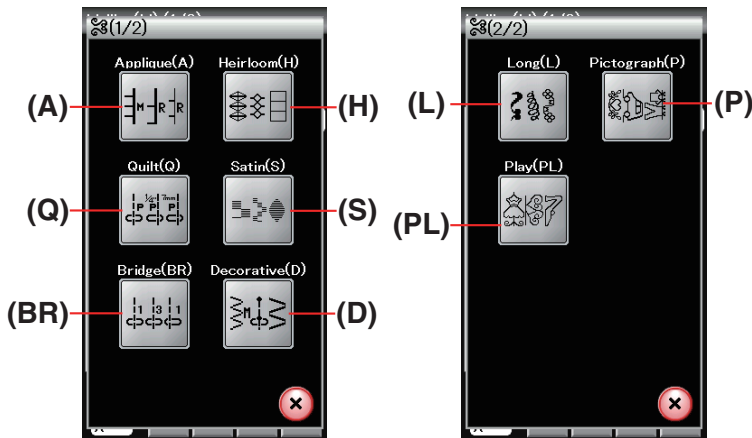

③

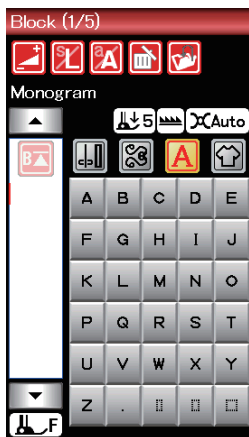

ORDINARY SEWING MODE

Ordinary Stitch Patterns

In the ordinary sewing mode, there are 4 categories available.

1. Utility stitches and Buttonholes
2. Decorative and quilting stitches
3. Monogramming
4. Sewing applications

Press one of the icon keys to select the category.

NOTE:

In this manual, the pattern number refers to the initial for each group.

For example pattern #3 in the Buttonhole is referred to as pattern B3.

① Utility stitches, Buttonholes and speciality stitches

You can select utility stitches (U), buttonholes and speciality stitches (B) in this category.

② Decorative and quilting stitches

This category consists of the following 9 groups.

- Applique stitches (A)
- Heirloom stitches (H)
- Quilting stitches (Q)
- Satin stitches (S)
- Bridge stitches (BR)
- Decorative stitches (D)
- Long stitches (L)
- Pictograph stitches (P)
- Play stitches (PL)

③ Monogramming

You can program lettering as well as a combination of characters.



④ Sewing applications

You can select the appropriate stitch for a specific sewing project and fabric type from the designated applications in this category.

Function Keys in Ordinary Sewing Mode

① Adjust key

Press this key to open the manual setting window. You can adjust the settings of the stitch width, stitch length, thread tension, and cloth guide position. (refer to pages 33-35).

② Twin needle key

Press this key to set the stitch width for twin needle sewing (refer to page 51). The key will be grayed out if the selected pattern is not suitable for twin needle sewing.

③ Program key

Press this key to program a pattern combination. When this key is pressed, the cursor keys, mirror image keys, delete key and save file key will appear.

④ Vertical mirror image key

Press this key to sew a vertical mirror image of the selected pattern (refer to page 52).

⑤ Horizontal mirror image key

Press this key to sew a horizontal mirror image of the selected pattern. The key is grayed out if the selected pattern cannot be turned over (refer to page 52).

⑥ Delete key

Press this key to delete the pattern from the pattern combination.

⑦ Save file key

Press this key to save the pattern combination as a file.

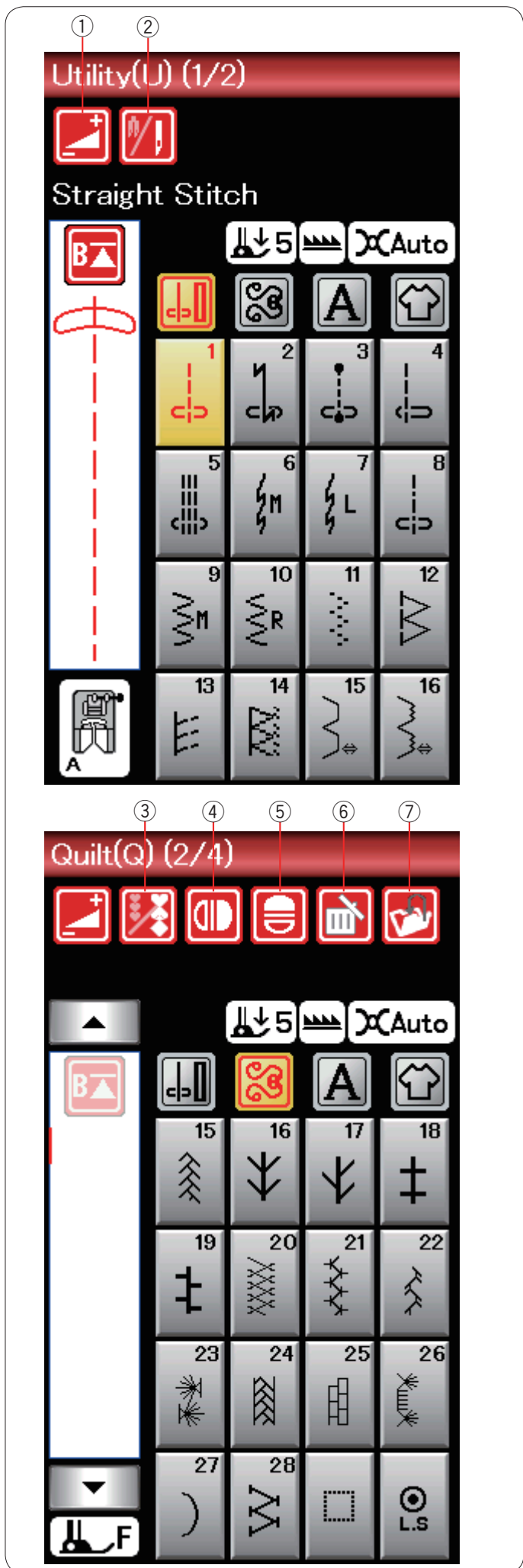

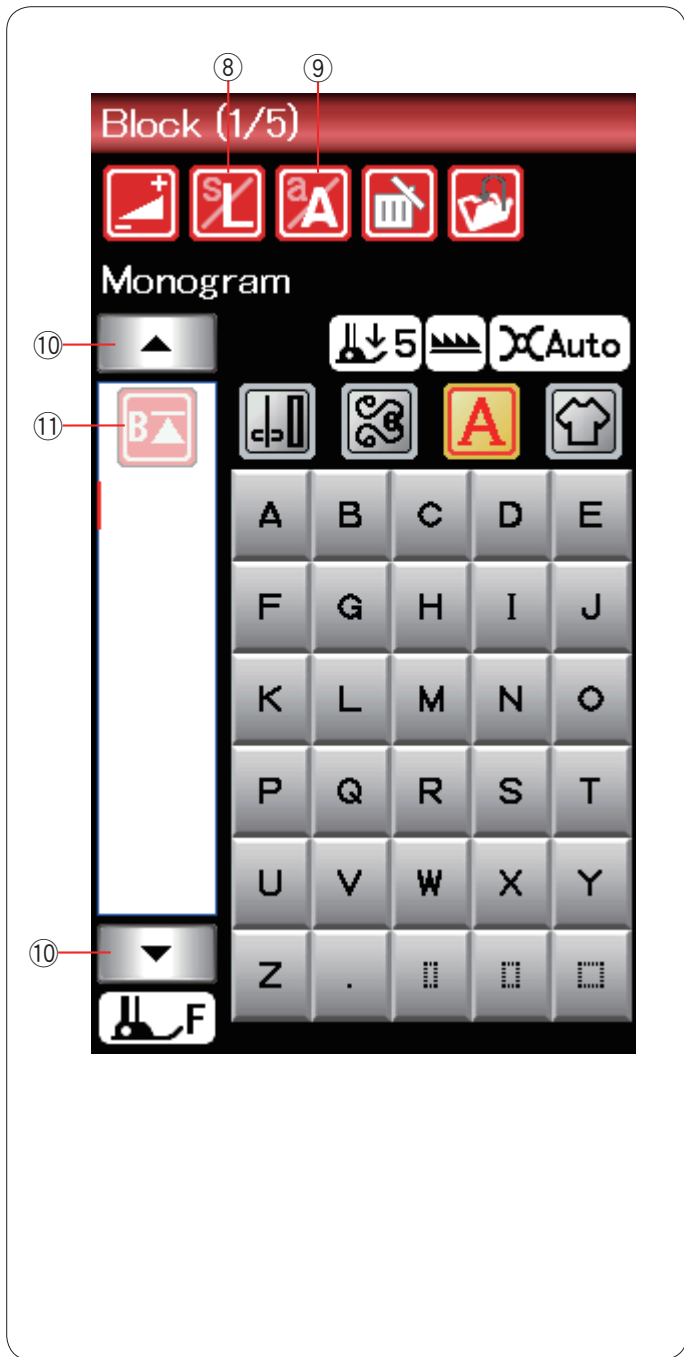

⑧ **Letter size key**
Press this key to select the letter size for monograms.

⑨ **Letter case key**
Press this key to select upper case or lower case for monograms.

⑩ **Cursor keys**
Press one of the cursor keys to move the cursor up or down.

⑪ **Starter key**
This key will appear when you stop sewing.

If you stop sewing in the middle of a stitch pattern and wish to sew the pattern again from the beginning, press this key before you start sewing. Press this key once to startover from the beginning of the current pattern, or press this key twice to startover from the beginning of the first pattern of the combination (refer to page 54).

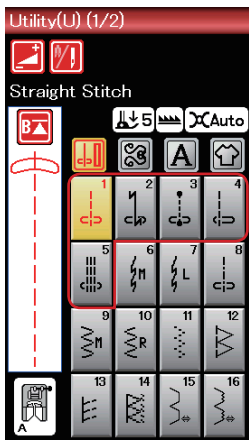

Utility Stitches

Straight stitches

Patterns U1 to U5 are straight stitches for seaming. Press the pattern selection key for the desired stitch.

NOTE:

When sewing fine fabrics with straight stitch, select patterns U1, U2 or U3, and use straight stitch needle plate for better sewing result (refer to page 19).

Starting to sew

Place the fabric next to a seam guide line on the needle plate. Lower the needle to the point where you want to start.

Pull the needle thread towards the rear and lower the foot.

Press the start/stop button or foot control to start sewing. Gently guide the fabric along the seam guide line letting the fabric go naturally.

- ① Start/stop button

NOTES:

- Pull the needle thread to the left when using satin stitch foot F or automatic buttonhole foot R.
- After using auto thread cutting or threading the bobbin holder, you can start sewing without drawing up the bobbin thread. However, you need to pull the needle thread towards the rear.

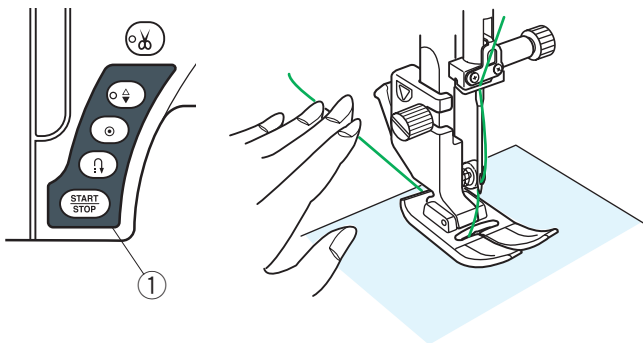

Sewing from the edge of thick fabric

The black button on the zigzag foot locks the foot in the horizontal position.

This is helpful when you start sewing at the extreme edge of thick fabrics or for sewing across a hem.

Lower the needle into the fabric at the point where you wish to start sewing.

Lower the foot while pushing in the black button. The foot is locked in the horizontal position to avoid slipping.

After a few stitches, the black button is released automatically.

- ② Black button

Changing sewing direction

Stop the machine and raise the presser foot lifter to raise the presser foot.

Pivot the fabric around the needle to change the sewing direction as desired.

Lower the presser foot.

Start sewing in a new direction.

Turning a square corner

To maintain a 5/8" seam allowance after turning a square corner, use the cornering guide on the needle plate.

Stop sewing when the front edge of fabric reaches the cornering guide lines.

Raise the presser foot lifter and turn the fabric 90 degrees.

Lower the presser foot.

Start sewing in the new direction.

- ③ Cornering guide

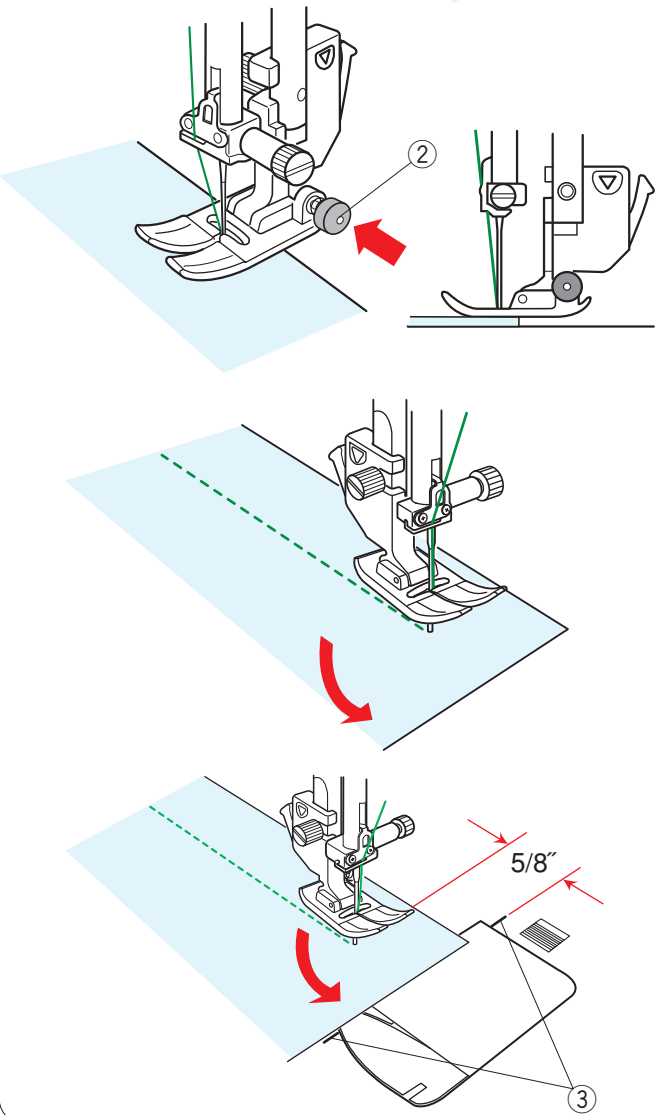

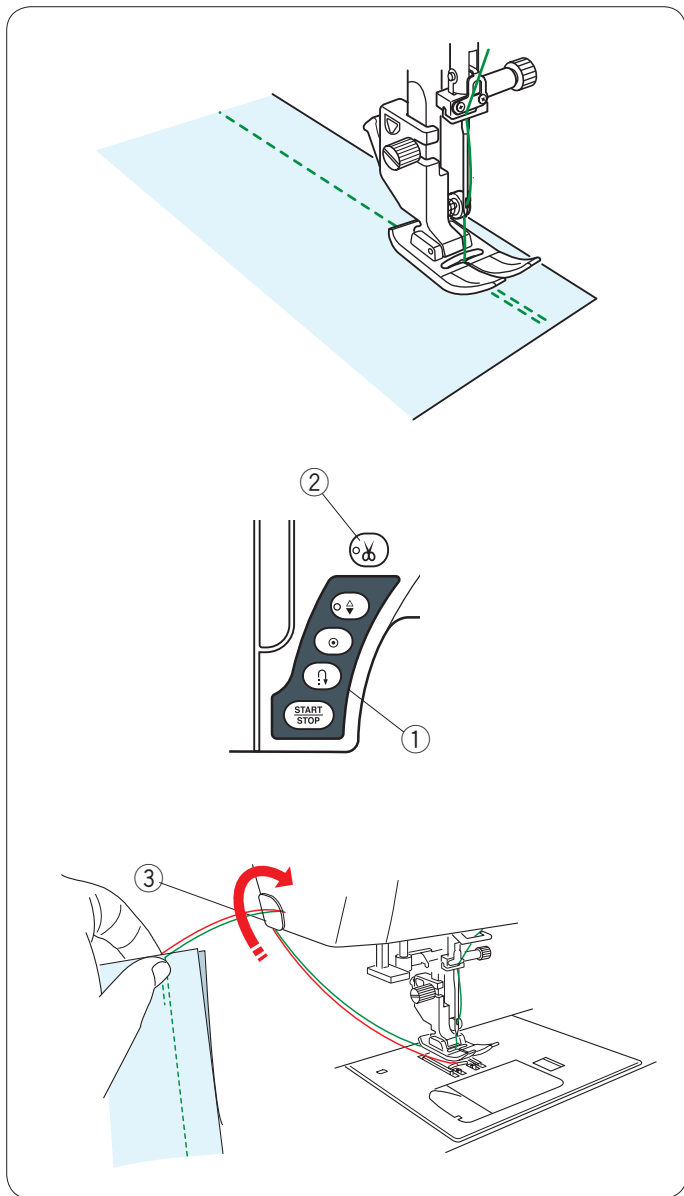

Securing seams

For fastening the ends of seams, press the reverse button and sew several reverse stitches.

The machine sews in reverse as long as you press and hold the reverse button.

- ① Reverse button

Press the reverse button once when sewing the lock-a-matic stitch (pattern U2) or locking stitch (pattern U3) and the machine will lock the stitches off and stop automatically.

Cutting threads

To cut the threads after finishing sewing, press the thread cutter button. The needle bar will automatically go up after trimming the threads.

- ② Thread cutter button

NOTES:

The thread cutter button does not function when the presser foot is up. Use the thread cutter on the face plate to cut specialized or thick threads if the auto thread cutter does not work well.

To use the thread cutter on the face plate, remove the fabric and draw it to the back.

Pull the threads up and slip them between the thread cutter and face plate from behind.

Pull the threads toward you to cut.

- ③ Thread cutter

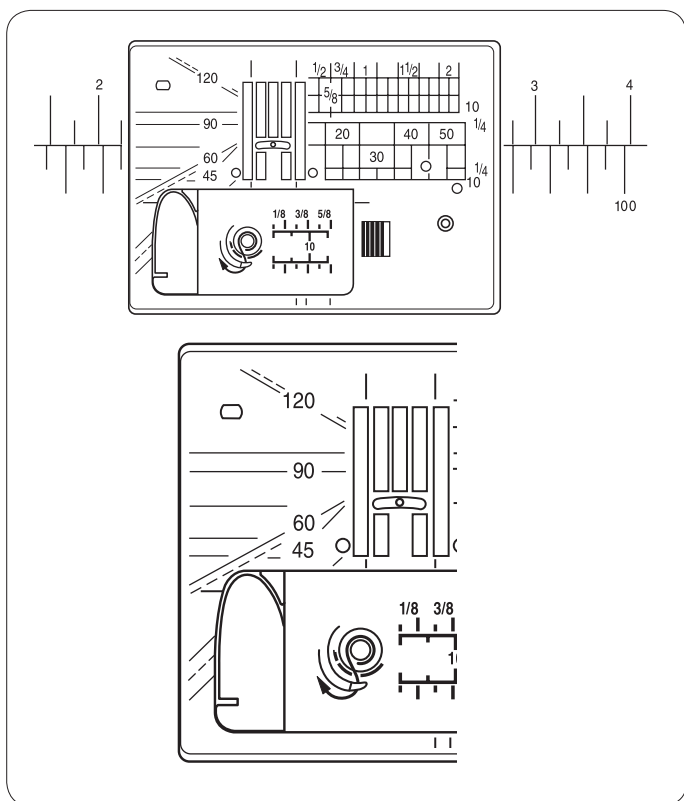

Using the seam guide lines

The seam guides on the needle plate and hook cover help you measure seam allowance.

NOTE:

The numbers on the needle plate indicate the distance from the center needle position in millimeters and inches.

Angle scale on the needle plate

The angle scales are marked at 45, 60, 90 and 120 degrees.

Use the broken lines when piecing patchwork pieces with the 1/4" seam foot O.

Variety of straight stitches

U1 Straight stitch in center needle position

Use this stitch for seaming, rolled hemming etc.

U2 Lock-a-matic stitch

Use this stitch to secure the beginning and the end of a seam with backstitching.

When you reach the end of the seam, press the reverse button once.

The machine will sew four reverse stitches, four forward stitches, and then stop sewing automatically.

U3 Locking stitch

This unique stitch is used where an invisible locking stitch is needed.

The machine will sew several locking stitches at the beginning and continue sewing forward.

When you press the reverse button at the end of the seam, the machine will sew several locking stitches in place, then stop sewing automatically.

U4 Straight stitch in left needle position

Use this stitch to seam fabrics close to the edge.

U5 Triple stretch stitch

This strong, durable stitch is recommended for areas where both elasticity and strength are needed to ensure comfort and durability.

Use it to reinforce areas such as crotch and armhole seams.

Also use it when constructing items such as backpacks for extra strength.

U6, U7 Stretch stitches

These are narrow stretch stitches designed to eliminate puckering on knit fabrics and bias seams, while permitting the seam to be pressed completely open flat.

Use U7 for seaming fine fabrics or stretch fabrics.

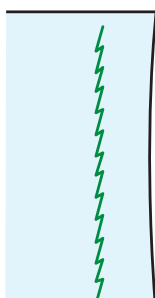
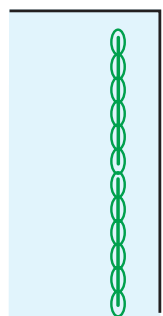
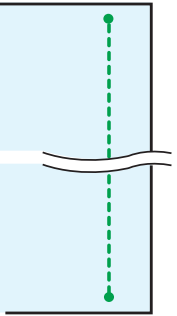
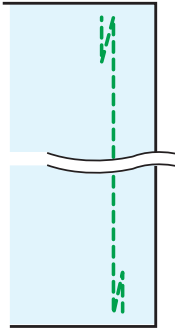
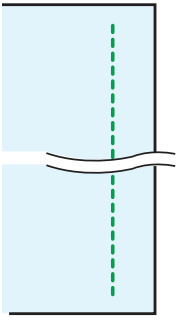

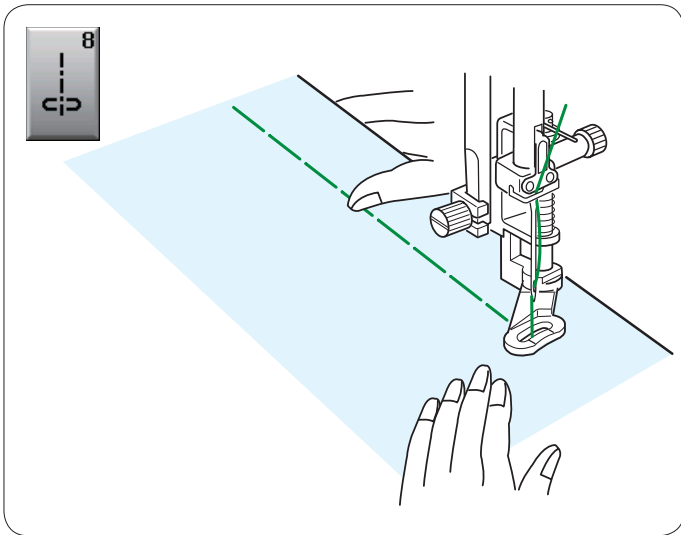

U8 Basting

See page 67 for sewing instructions.

Zigzag stitches

U9, U10 Zigzag stitches

Zigzag stitches are used for various sewing needs including overcasting. These stitches can be used on most woven fabrics.

A dense zigzag stitch can also be used for applique.

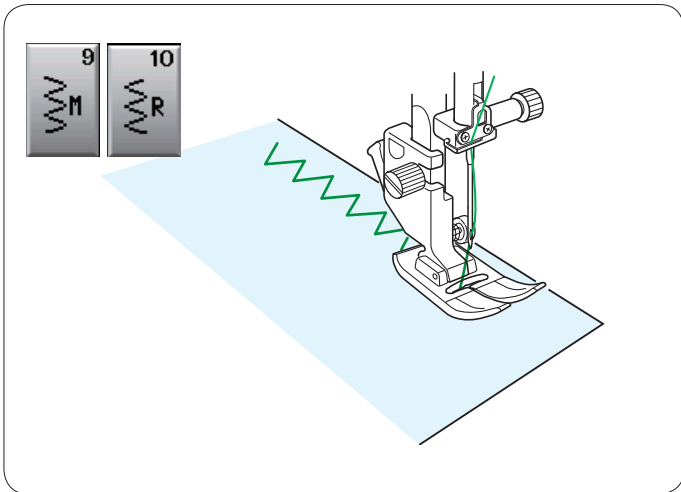

U11 Multiple zigzag stitch

These stitches are used for mending tears.

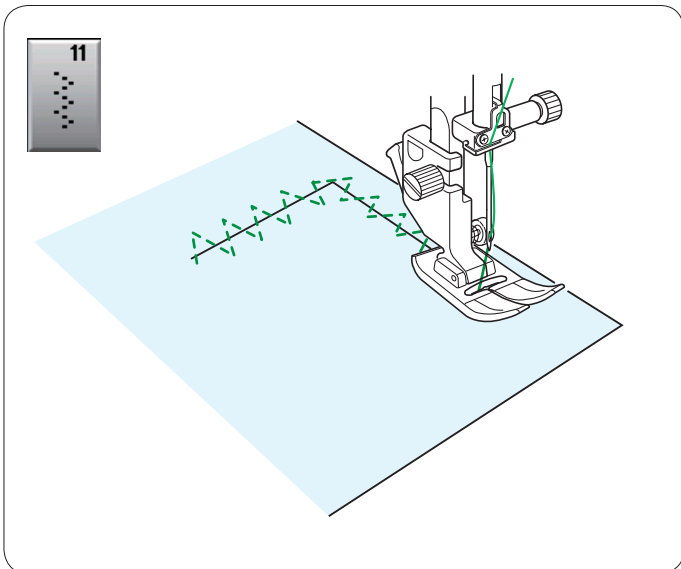

Variety of overcasting stitches

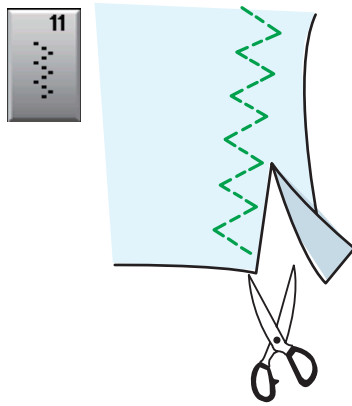

U11 Multiple zigzag stitch: Zigzag foot A

This stitch is used to finish a raw edge of synthetics and other stretch fabrics that tend to pucker.

Sew along the fabric edge leaving an adequate seam allowance. After sewing, trim off the seam allowance closer to the stitches.

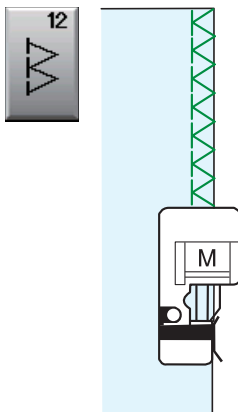

U12 Overcasting stitch: Overedge foot M

This stitch can be used to simultaneously seam and overcast edges of fabrics.

Use this stitch when you do not need to open seams flat. Place the fabric edge next to the guide of the foot and sew. The stitch width cannot be adjusted.

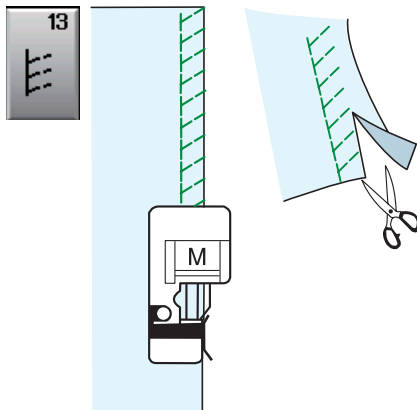

U13 Knit stitch: Overedge foot M

This stitch is recommended for sewing such fabrics as synthetic knits and stretch velour as it provides the greatest amount of elasticity and strength.

Place the fabric edge next to the guide of the foot and sew.

For better results, use the zigzag foot A and sew leaving an adequate seam allowance.

After sewing, trim the seam allowance close to the stitches.

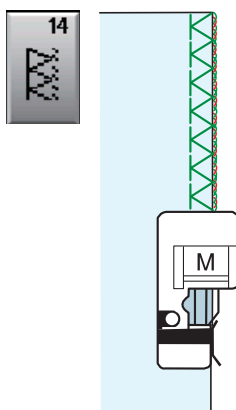

U14 Overlock stitch: Overedge foot M

This stitch finishes the edges of fabric in a way similar to a commercial overlocking machine for a professional look.

Place the fabric edge next to the guide of the foot and sew.

The stitch width cannot be adjusted.

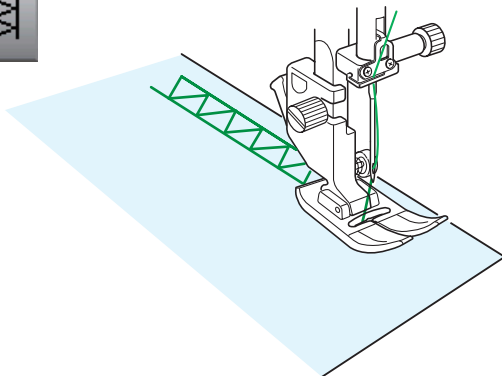
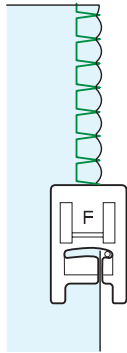
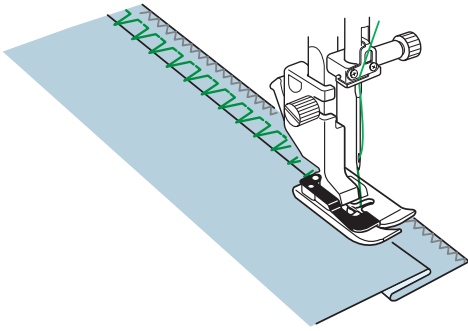
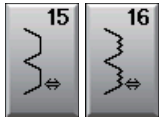

U15, U16 Blind hemming

See pages 61 and 62 for sewing instructions.

U17 Shell tuck

See page 62 for sewing instructions.

U18 Hemstitch

Use this stitch for fagoting or decorative stitch.

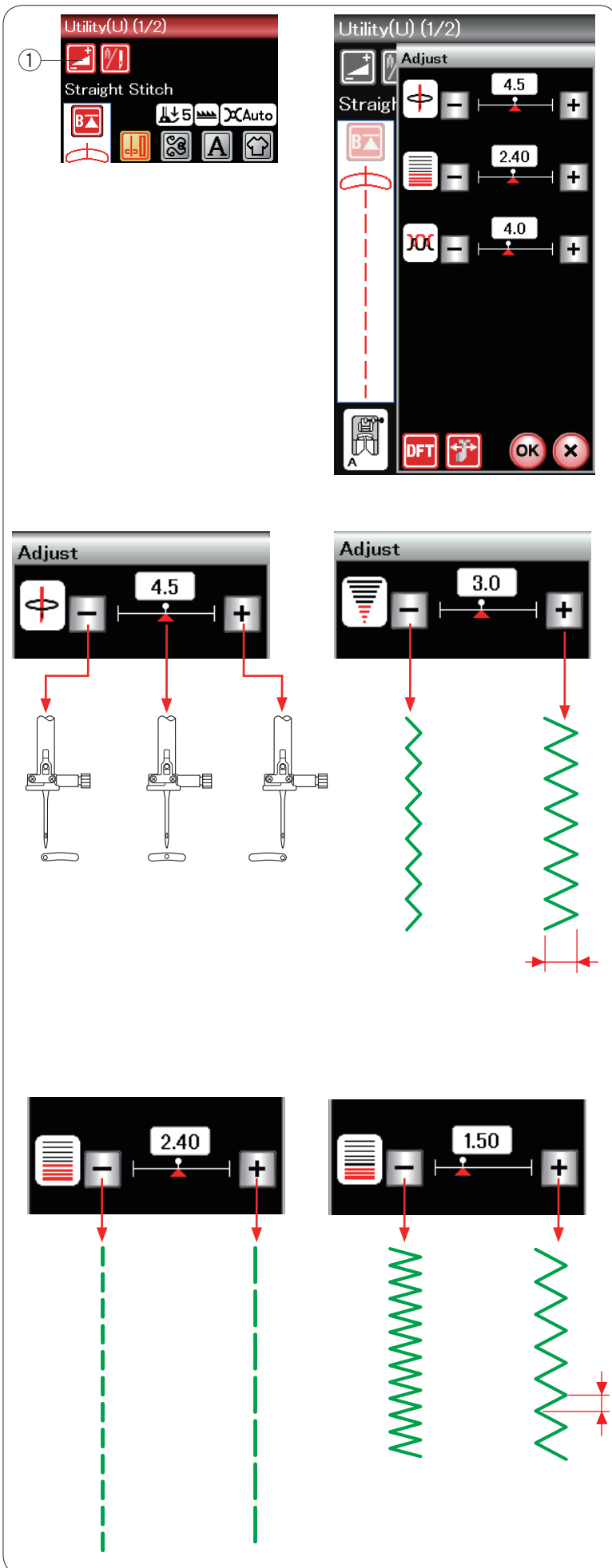

Manual Stitch Settings

When you press the adjust key, the screen shows the manual setting window.

① Adjust key

You can alter the stitch width (or needle drop position of the straight stitches), stitch length and needle thread tension.

Press the “+” or “-” key beside the setting you wish to change.

Altering needle drop position (straight stitches)

Press the “+” key to move the needle drop position to the right.

Press the “-” key to move the needle drop position to the left.

Altering stitch width

Press the “+” key to increase the stitch width.
Press the “-” key to decrease the stitch width.

NOTE:

The adjustable range of patterns U6, U7, U9, U10 and U11 is 0.0 to 7.0.

Altering stitch length

Press the “+” key to increase the stitch length.
Press the “-” key to decrease the stitch length.

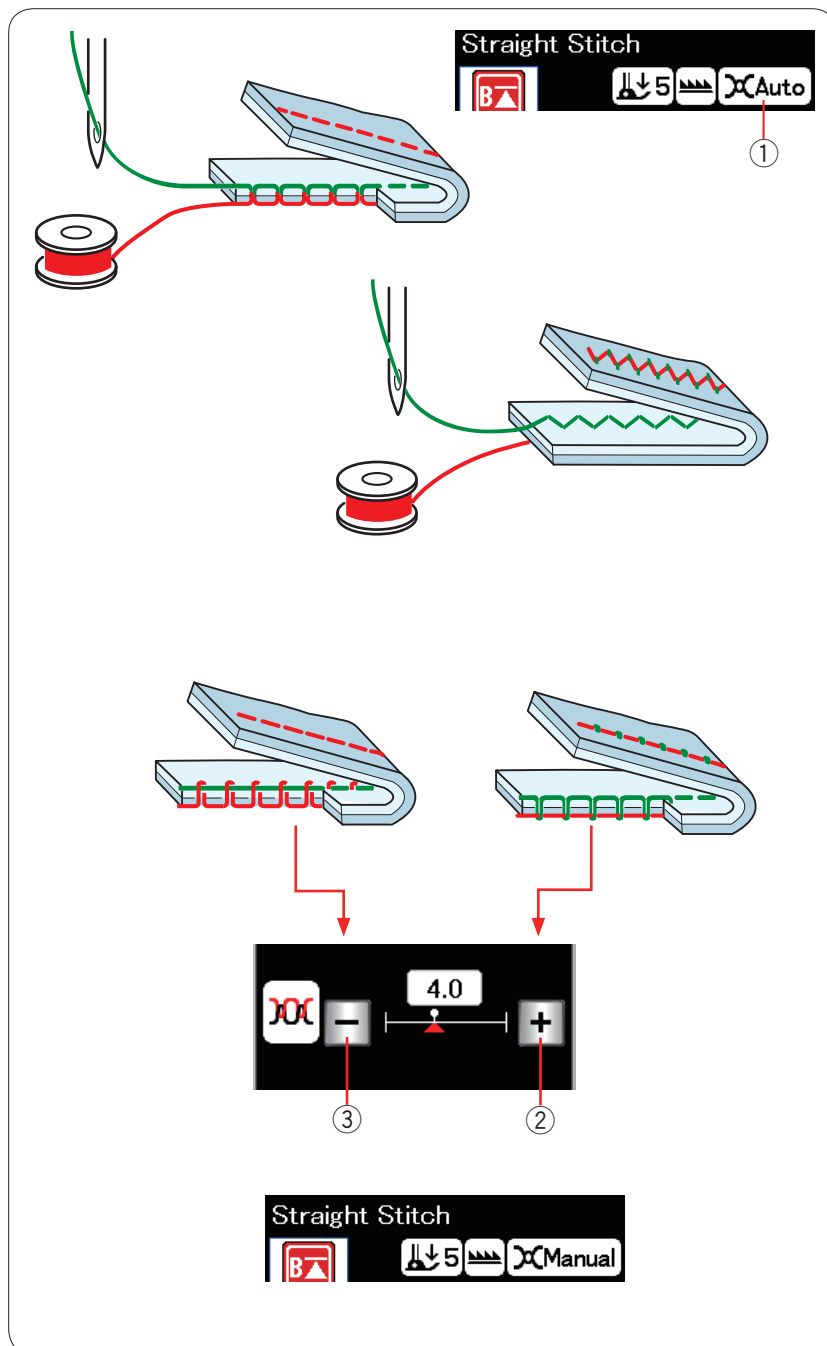

Adjusting thread tension

This machine is equipped with automatic thread tension control, which optimizes the tension balance for the selected stitch pattern. "Auto" will be indicated in the thread tension window when automatic thread tension control is applied to the selected stitch pattern.

① Thread tension window

Balanced thread tension

Straight stitch: Both needle and bobbin threads interlock between the layers.

Zigzag stitch: The needle thread appears slightly on the wrong side of the fabric.

However, you may need to manually adjust the tension balance depending on the sewing conditions, or you can fine-tune the thread tension to suit your preference.

② Press the "+" key if the tension is too loose.

③ Press the "-" key if the tension is too tight.

When manual thread tension control is applied, "Manual" will be indicated in the thread tension window.

Cloth guide

⚠ CAUTION:

Always leave sufficient space to the left of the machine when using the cloth guide.

Do not use the cloth guide when the buttonhole foot R is attached.

The extension table cannot be opened when the cloth guide is in use.

Attaching the cloth guide

Attach the embroidery unit (refer to page 83).

Insert the pin on the cloth guide into the carriage hole. Turn the attaching knob clockwise to secure the cloth guide.

- ① Pin
- ② Cloth Guide
- ③ Carriage Hole
- ④ Attaching knob

Setting the cloth guide position

Press the adjust key to open the manual setting window. Press the cloth guide key.

- ⑤ Cloth guide key

The visual touch screen will show a warning message. Press the **OK** key.

The cloth guide adjustment window will open.

Press the **◀ 1** **◀ 0.1** or **0.1 ▶** **▶ 1 ▶** keys to move the cloth guide to the desired position.

The cloth guide will move the distance indicated on the key.

The cloth guide position is indicated on the scale bar and the distance from the center needle drop position is indicated in millimeters or inches.

NOTE:

The machine will not run if the cloth guide adjustment window is open.

Press the default key to return the cloth guide to the default position (15 mm or 5/8").

- ⑥ Default key

Make sure to return the carriage to the stored position by pressing the cloth guide storage key and remove the cloth guide after you finish sewing.

- ⑦ Cloth guide storage key

Press the **OK** key to register the setting and close the cloth guide adjustment window.

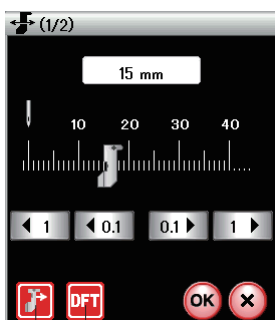
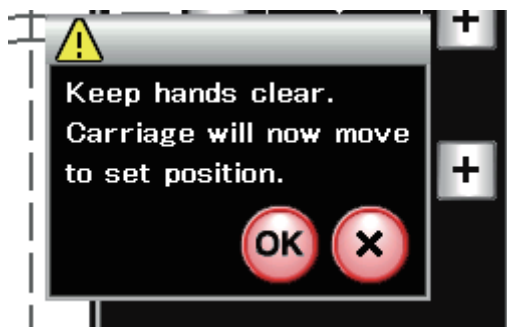
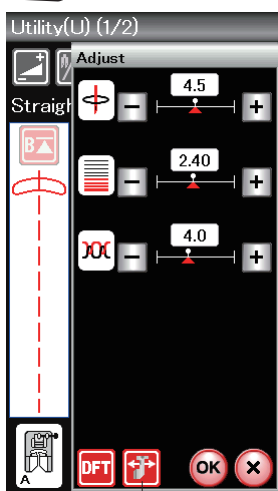
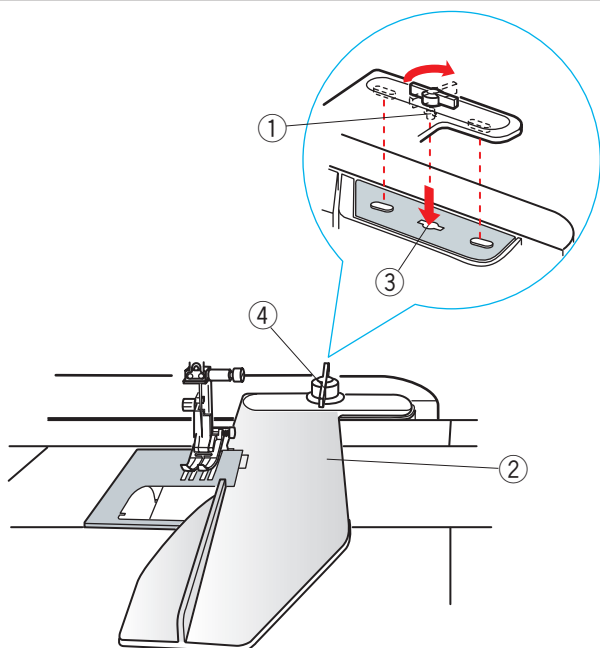

- ⑦
- ⑥

Buttonholes and Specialty Stitches

Variety of buttonholes



B1 Sensor (Square) buttonhole

This square buttonhole is widely used on medium to heavy weight fabrics. The buttonhole size is automatically determined by placing a button in the foot.

B2 Auto (Square) buttonhole

This is also a square buttonhole similar to the sensor square buttonhole, but you can manually set the buttonhole size and the machine memorizes it to sew buttonholes of the same size.

B3 Round end buttonhole

This buttonhole is used on fine to medium weight fabrics especially for blouses and children's clothes.

B4 Fine fabric buttonhole

This buttonhole is rounded at both ends and is used on fine, delicate fabrics such as fine silk.

B5 Keyhole buttonhole

The keyhole buttonhole is widely used on medium to heavy weight fabrics. It is also suitable for larger and thicker buttons.

B6 Stretch buttonhole

This buttonhole is suitable for stretch fabrics. It can also be used as a decorative buttonhole.

NOTE:

B3-B6 are sensor buttonholes and the sewing procedure is the same as for B1.

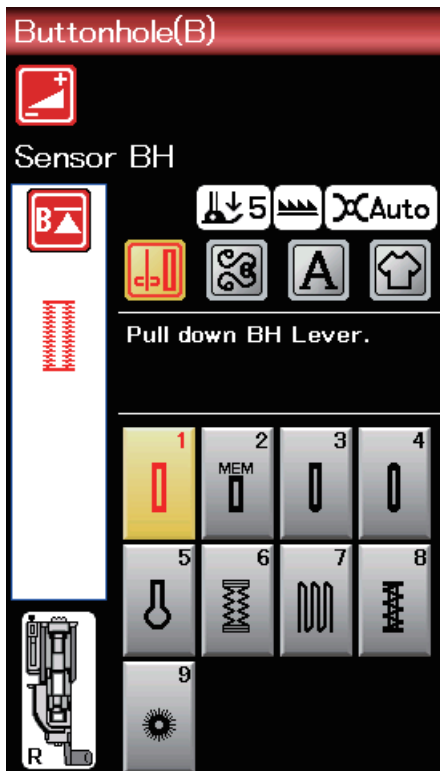

B1 Sensor (Square) buttonhole

- 1 Pull open the button holder of the automatic buttonhole foot R, and place the button in the button holder. Push it tightly against the button.
 - ① Button holder

NOTE:

Use the blue needle for sewing buttonholes on fine to medium fabrics.

- 2 Attach the buttonhole foot. Raise the presser foot.

NOTES:

The buttonhole size is automatically set by placing a button into the button holder on the foot.

The button holder of the foot takes a button size of up to 2.5 cm (1") in diameter.

Make a test buttonhole on an extra piece of the fabric. Check the length of the test buttonhole, and adjust the buttonhole length if necessary by turning the adjusting screw on the buttonhole foot.

To increase the buttonhole length, turn the adjusting screw to move the marker toward "L".

To decrease the buttonhole length, turn the adjusting screw to move the marker toward "S".

- ② Adjusting screw
- ③ Marker

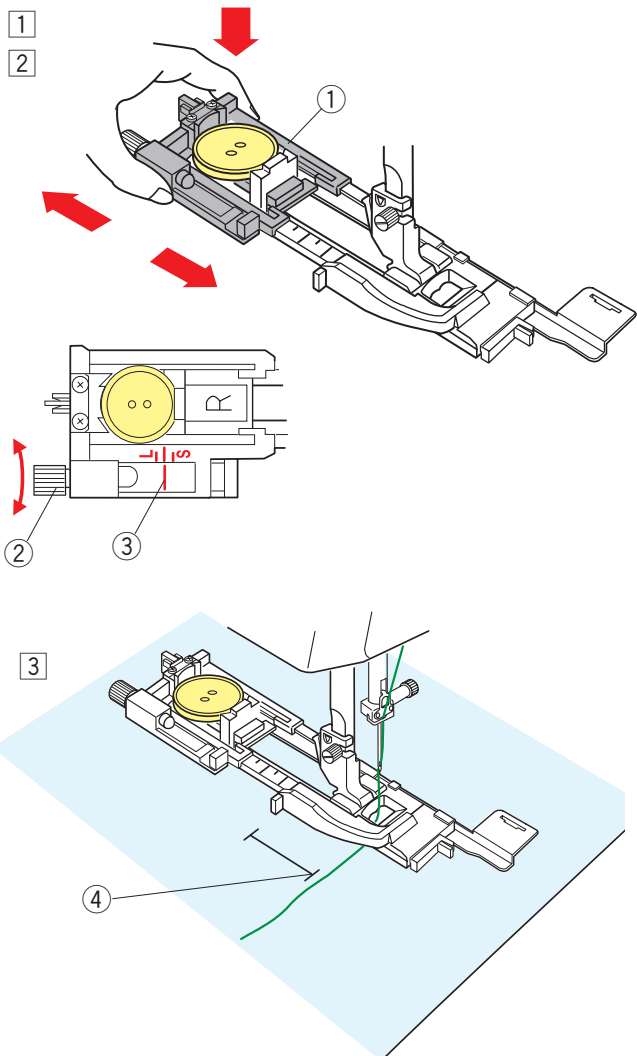

- 3 Mark the buttonhole position on the fabric and place it under the buttonhole foot. Lower the needle at the starting point by turning the hand wheel.

Draw the needle thread to the left through the hole of the foot.

- ④ Starting point

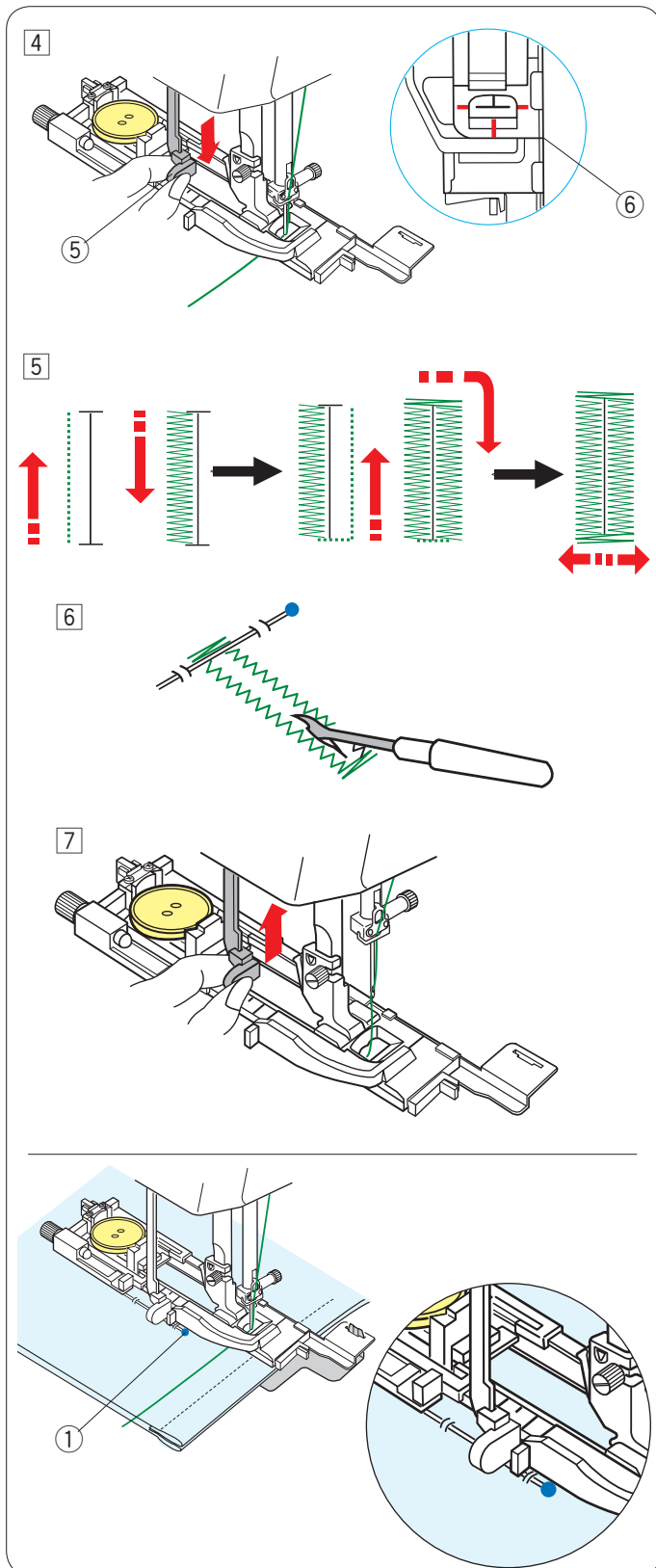

- 4 Lower the buttonhole foot and pull down the buttonhole lever as far as it will go. Start sewing while pulling the needle thread lightly to the left. After sewing a few stitches, free the thread and continue sewing.
- 5 Buttonhole lever

NOTE:

A warning message will appear and the machine will stop automatically if you start the machine without pulling down the buttonhole lever. Press the X key, pull down the buttonhole lever and start again. Make sure there is no gap between the slider and front stopper, otherwise the buttonhole will be out of position or the left and right lengths will be different.

- 6 No gap

- 5 The buttonhole is sewn automatically in the sequence shown. When the buttonhole is finished, the machine will stop automatically with the needle in the up position. Press the thread cutter button and remove the fabric.

- 6 Place a pin just below the bartack at each end to prevent accidentally cutting the threads. Cut the opening with the seam ripper. Use an eyelet puncher to open a keyhole buttonhole.

- 7 After you finish buttonhole sewing, push the buttonhole lever up as far as it will go.

Patterns B3 to B6 are sensor buttonholes and the sewing procedure is the same as for buttonhole B1.

However, the sewing sequence varies depending on the type of the buttonhole.

NOTE:

Use the stabilizer plate when sewing thick fabrics or sewing across hems (refer to page 40).

NOTE:

When sewing a buttonhole on thick fabric which has a bulky texture such as fleece, the fabric may move the BH lever and cause a deformed buttonhole. Use a pin ① to hold the fabric flat and prevent it from wrinkling while feeding the fabric. Make sure the fabric does not move the lever when sewing.

Double layer buttonhole

To make a sturdy buttonhole, sew another layer of buttonhole stitches over the previous stitches. After the buttonhole is finished, do not cut the thread. Simply start the machine again. Do not raise the foot or buttonhole lever.

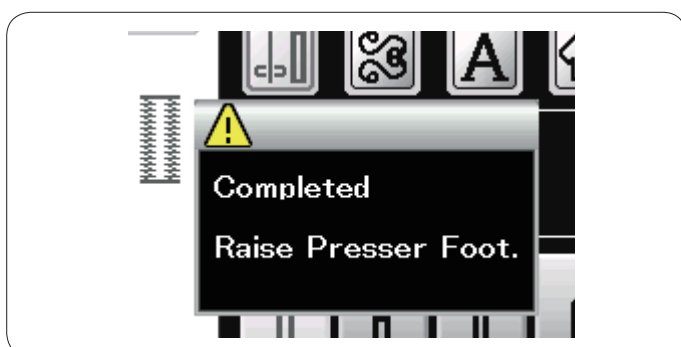

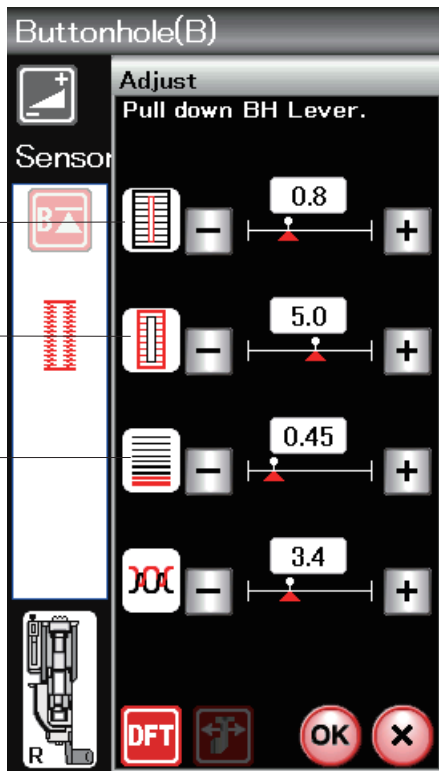

①

②

③

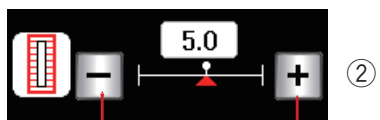
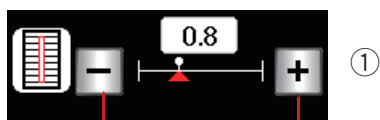

Manual settings

Press the adjust key and the manual setting window will open.

① Altering buttonhole opening width

Press the “+” key to make the buttonhole opening wider.
Press the “-” key to make the buttonhole opening narrower.

② Altering buttonhole width

Press the “+” key to increase the buttonhole width.
Press the “-” key to decrease the buttonhole width.

③ Altering buttonhole stitch density

Press the “+” key to make the buttonhole stitches less dense.
Press the “-” key to make the buttonhole stitches denser.

Press the OK key to register the settings.

NOTE:

The opening width can be adjusted from 0.2 to 2.0.
The buttonhole width can be adjusted from 2.6 to 7.0.
The stitch density can be adjusted from 0.30 to 1.00.

Using the Stabilizer Plate

The stabilizer plate holds and supports the fabric so it is helpful when sewing buttonholes over the hem of thick fabrics.

- 1 Insert the tab of the stabilizer plate ① into the slot ② of the buttonhole foot.

- ① Stabilizer plate
- ② Slot

- 2 Place the button on the button holder of the foot. Attach the buttonhole foot to the machine. Insert the fabric between buttonhole foot and stabilizer plate. Draw the needle thread to the left between the foot and stabilizer plate.

- 3 Place the fabric between the buttonhole foot and stabilizer plate. Lower the needle into the starting point by turning the hand wheel. Lower the foot and buttonhole lever. Start the machine while pulling the needle thread lightly to the left. After sewing a few stitches, free the thread and continue sewing.

NOTE:

The sewing procedure is exactly the same as that for B1 sensor (square) buttonholes.

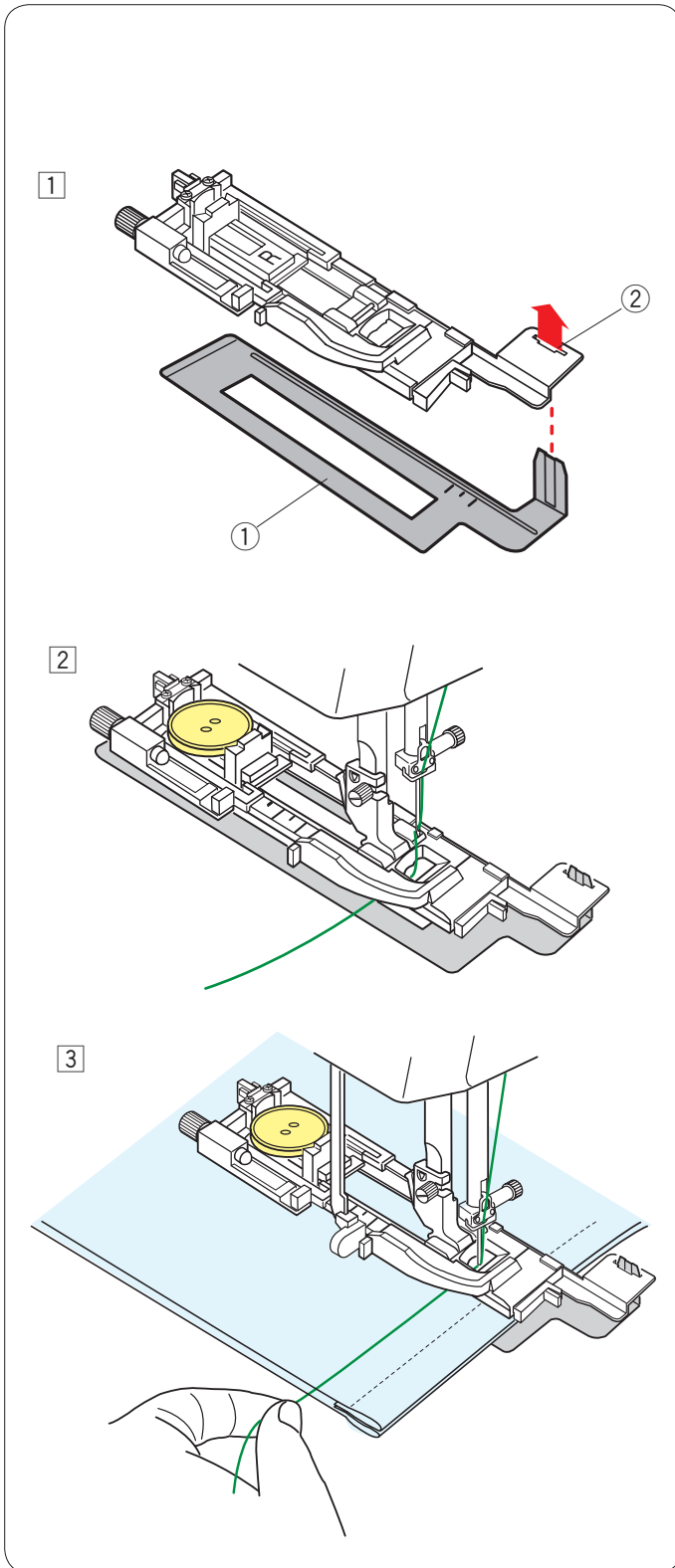

B2 Automatic (square) buttonhole

Pull the button holder all the way out.

Mark the buttonhole position on the fabric.

Place the fabric under the foot, and lower the needle at the starting point.

Lower the foot and start sewing while pulling the needle thread lightly to the left. After sewing a few stitches, free the thread and continue sewing.

NOTE:

You do not need to pull down the buttonhole lever.

If you wish to sew a buttonhole longer than the size permitted by the automatic buttonhole foot R, use satin stitch foot F.

NOTE:

The opening width can be adjusted from 0.2 to 2.0.

The buttonhole width can be adjusted from 2.6 to 7.0.

The stitch density can be adjusted from 0.30 to 1.00.

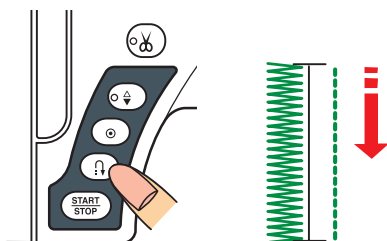
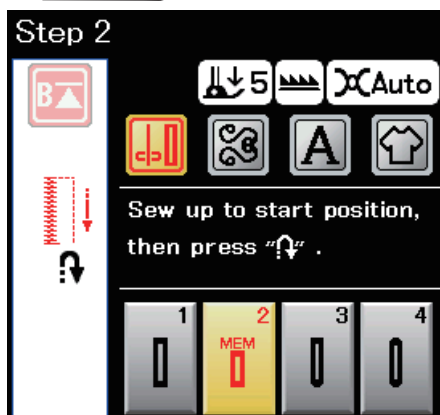
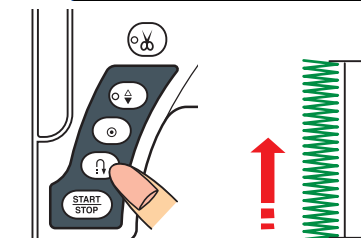
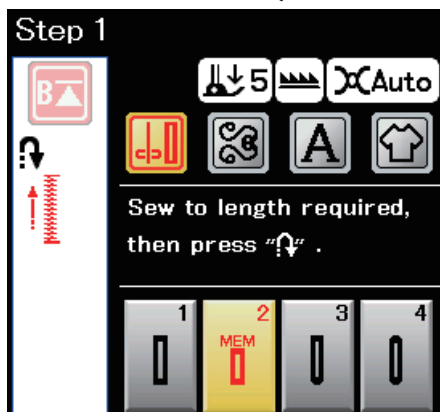
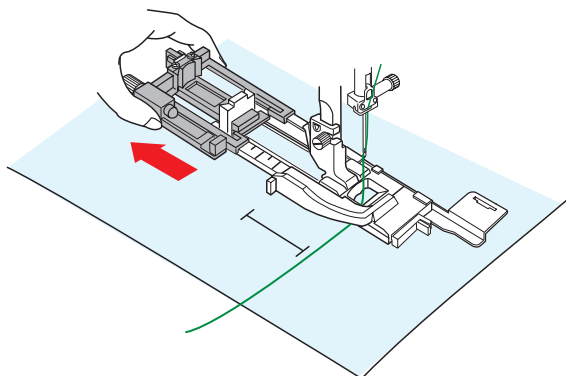
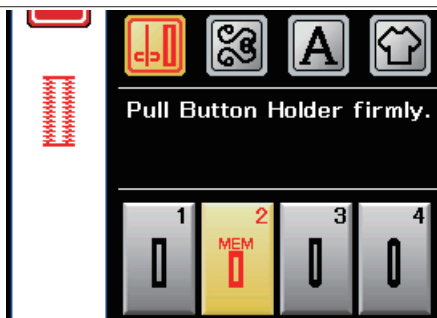

Step-1

Sew the left side up to the required buttonhole length and stop the machine. Then press the reverse button.

Step-2

Start sewing again, and the machine sews back with a straight stitch.

Stop the machine when you reach the starting point.

Then press the reverse button.

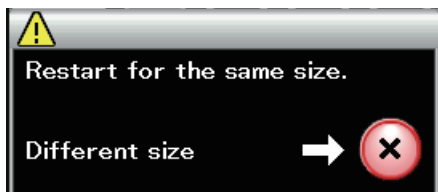
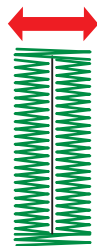
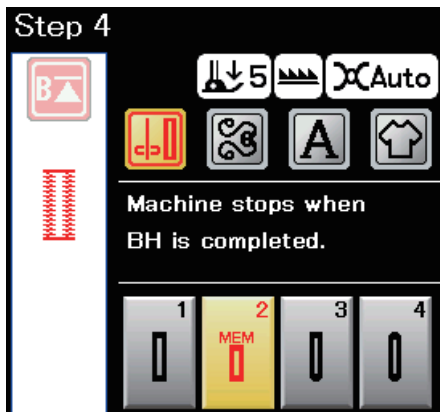
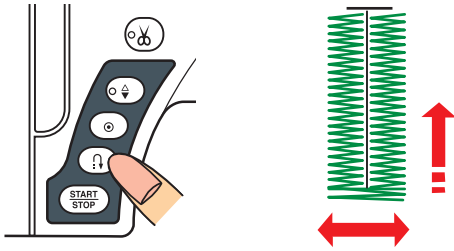
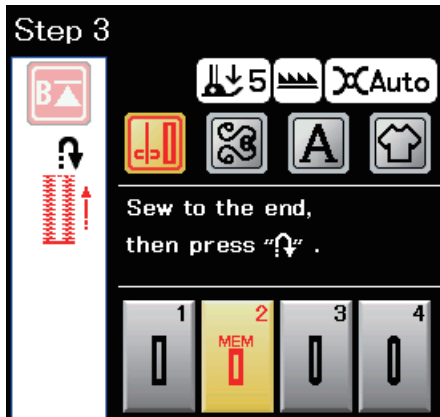

Step-3

Start sewing again, and the machine sews the front bartack and right side of the buttonhole.

Stop the machine when you reach the ending point.

Then press the reverse button.

Step-4

Start sewing again, and the machine sews the back bartack and locking stitches then stops automatically with the needle in the up position.

When the buttonhole is finished, a message will appear.

To make the next buttonhole, position the fabric and start sewing again. The message disappears and the machine sews another buttonhole identical to the first one then stops automatically.

To sew another buttonhole in a different size press the X key.

NOTES:

To cut the buttonhole opening, refer to the instructions on page 38.

The memorized length will be cancelled if the startover key is pressed before buttonhole is completed or the other stitch patterns are selected.

Other buttonholes

B3 Round end and B4 fine fabric buttonholes

The sewing procedure is the same as that of B1 sensor (square) buttonhole (refer to page 37).

NOTE:

The opening width can be adjusted from 0.2 to 2.0.
The buttonhole width can be adjusted from 2.6 to 5.4.
The stitch density can be adjusted from 0.30 to 1.00.

B5 Keyhole buttonhole

The sewing procedure is the same as B1 sensor (square) buttonhole (refer to page 37).

Use an eyelet punch to open the keyhole buttonhole.

NOTE:

The opening width can be adjusted from 0.2 to 2.0.
The buttonhole width can be adjusted from 5.6 to 7.0.
The stitch density can be adjusted from 0.30 to 1.00.

B6 Stretch buttonhole

The sewing procedure is the same as B1 sensor (square) buttonhole (refer to page 37).

The sewing steps are as shown.

NOTE:

The opening width can be adjusted from 0.2 to 2.0.
The buttonhole width can be adjusted from 2.6 to 7.0.
The stitch density can be adjusted from 0.50 to 1.00.

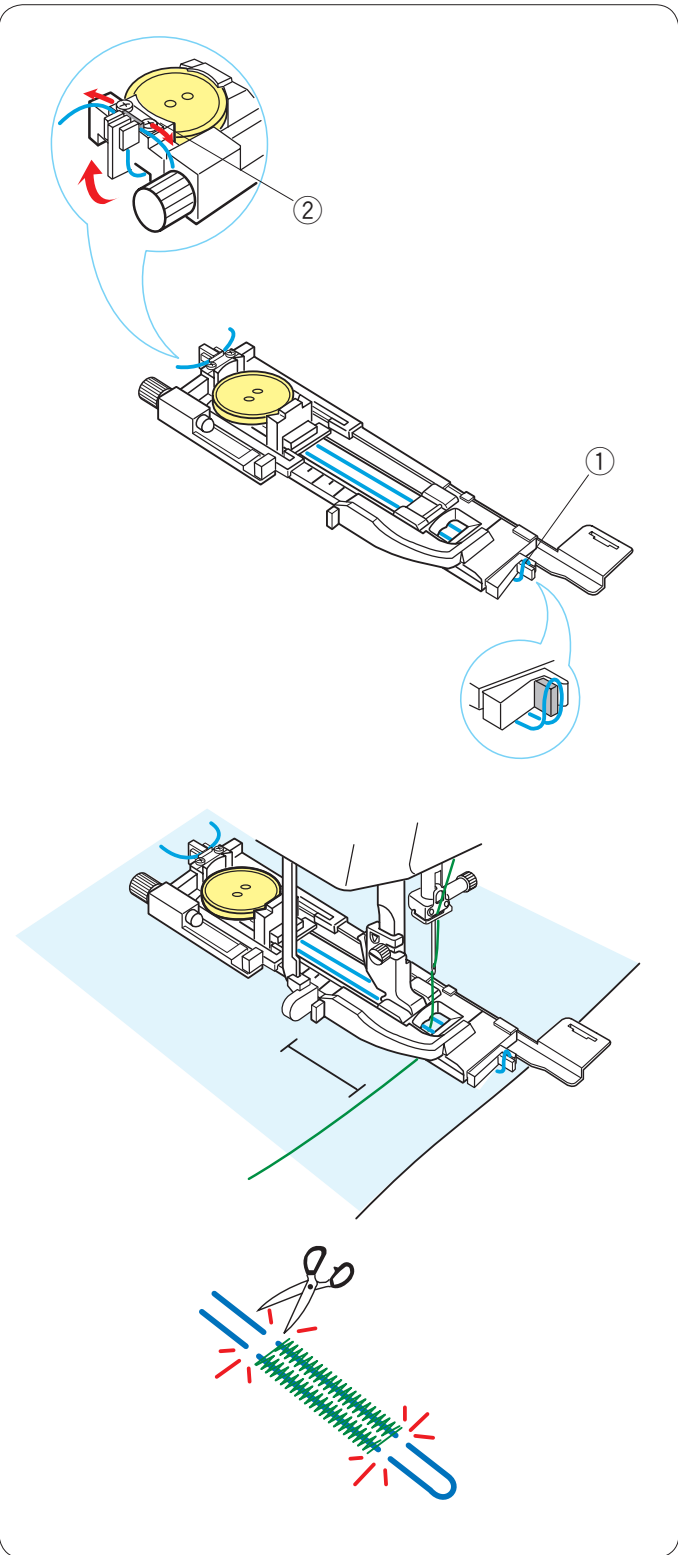

Corded buttonhole

To sew a corded buttonhole, follow the same procedure as for B1 sensor (square) buttonhole.

Select pattern B1.

Place the button on the button holder on the buttonhole foot.

Hook a filler cord on the spur on the front of the foot. Bring the ends of cord toward back and under the foot. Bring up the ends of the cord and insert both ends between the ribs and metal plate.

- ① Spur
- ② Metal plate

Set the stabilizer plate as necessary and attach the buttonhole foot.

Lower the needle into the fabric where the buttonhole will start.

Lower the foot and buttonhole lever.

Pull the needle thread lightly to the left.

Start the machine.

After sewing a few stitches, free the thread and continue sewing.

Sew the buttonhole over the cord.

The machine stops automatically when finished.

Remove the fabric from the machine and cut the sewing threads only.

Cut the filler cord at both ends as close to the buttonhole as possible.

NOTES:

Do not adjust the opening width wider than 0.8.

Set the stitch width in accordance with the thickness of the cord used.

To cut the buttonhole opening, refer to the instructions on page 38.

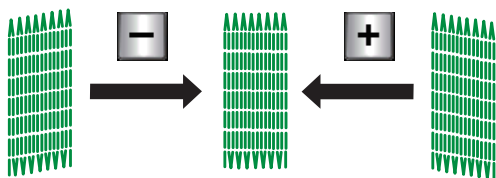
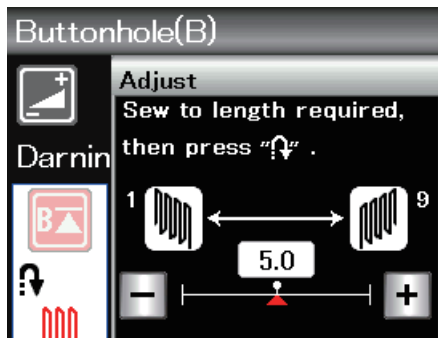
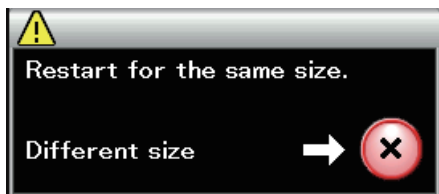
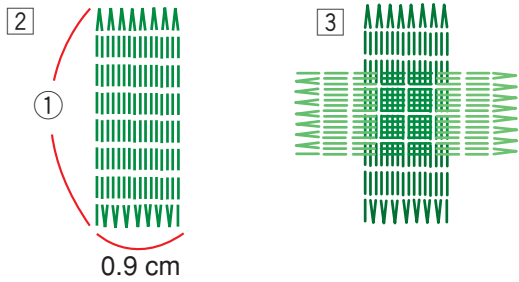
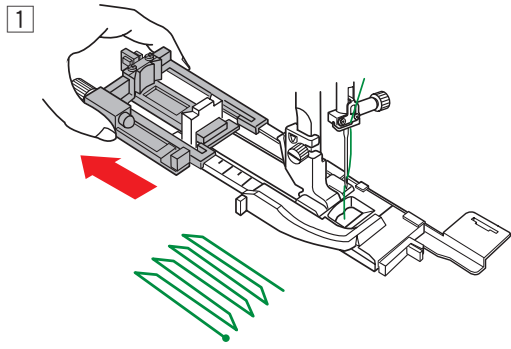

B7 Darning

- 1 Attach the automatic buttonhole foot R and pull the button holder all the way out.
- 2 Start the machine and sew to the required length, then press the reverse button. This sets the darning length. Continue sewing until the machine stops automatically.
 - 1 Required length
- 3 Sew another layer of darning over the first layer, at a right angle to it.

NOTE:

The maximum darning length is 2 cm (3/4") and the maximum width is 0.9 cm (3/8").

To sew the same size darning

When sewing is finished, a confirmation message will appear.

Simply start the machine to sew another layer of darning in the same size.

To sew the next layer of darning in a different size, press the X key.

To adjust the evenness of darning stitches:

You can correct unevenness of darning stitches by pressing the "-" or "+" key in the adjusting window. If the left corner is lower than the right side, press the "-" key to correct it, and vice versa.

NOTE:

See page 69 for sewing instructions of B8 Tacking.

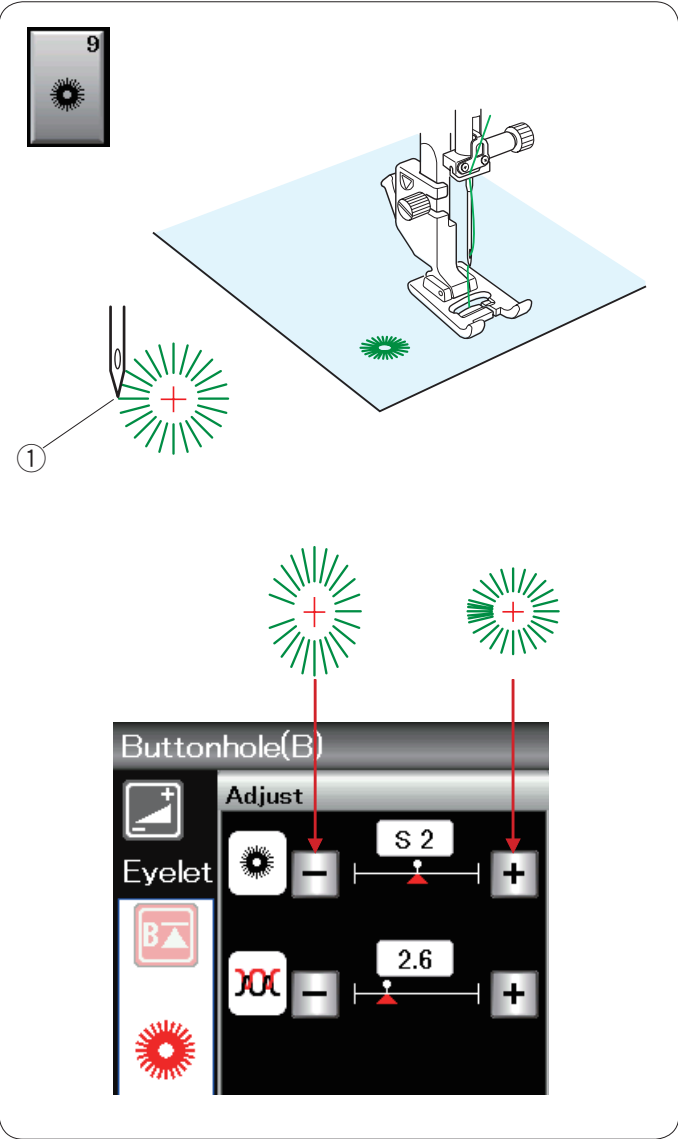

B9 Eyelet

The eyelet is used for belt holes, etc.
Attach the satin stitch foot F.

Place the garment under the foot and lower the needle to the starting point.

Sew until the machine stops automatically.

- ① Starting point

Open the eyelet with an awl, puncher or pointed scissors.

To correct the shape of an eyelet:

If the eyelet is open, press the “-” key.

If the eyelet overlaps, press the “+” key.

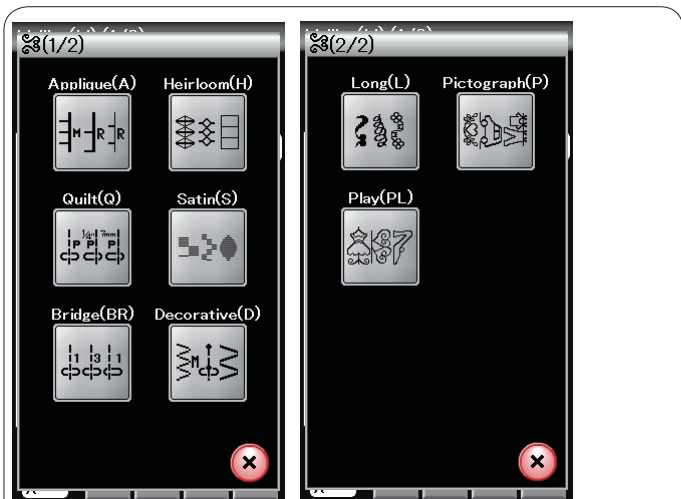

Decorative Stitches

The patterns in this section are classified into 9 groups. These patterns are programmable and you can make a pattern combination.

Applique stitches (A): 1 page

Stitches in this group are for applique. (Refer to page 70.)

Heirloom stitches (H): 2 pages

This group provides heirloom stitches and cross stitches for craft sewing and home décor.

Quilting stitches (Q): 4 pages

Stitches in this group are for patchwork and quilting. (Refer to pages 71-74.)

Satin stitches (S): 1 page

The stitches in this group can be elongated up to 5 times their original length while the stitch density remains the same. (Refer to page 50.)

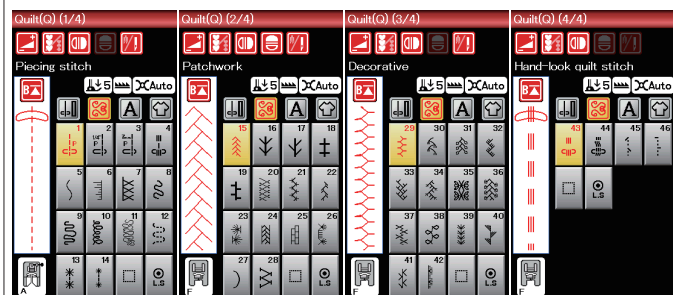
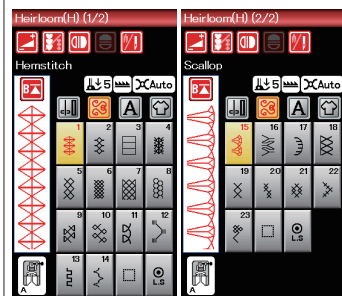
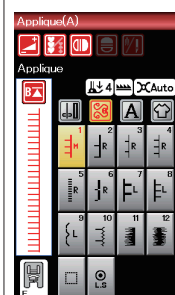



Bridge stitches (BR): 1 page

Bridge stitches are used for inserting straight stitches after a stitch pattern. The number beside the stitch image on the straight stitch key indicates the stitch count of a programmable unit. Patterns BR5 and BR7 will inherit the needle drop position and stitch length of the previous pattern in the programmed pattern combination.

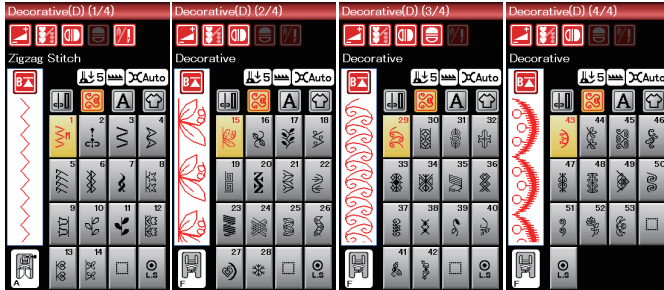

Decorative stitches (D): 4 pages

More than 50 attractive patterns are available in this group.



Long stitches (L): 1 page

Patterns in this group are ideal for decorating garments and for adding border trims.



Pictograph stitches (P): 1 page



Play stitches (PL): 1 page

There are cute designs, fancy motifs and calligraphy available in these groups.

Quilting(Q)

Using the quilting guide bar

The quilting guide bar is helpful when sewing parallel, evenly spaced rows of stitches.

Insert the quilting guide bar into the hole in the back of the foot holder. Slide the quilting guide bar and set it to the desired spacing.

- ① Quilting guide bar
- ② Hole

Sew rows of stitches while tracing the previous row of stitches with the quilting guide bar.

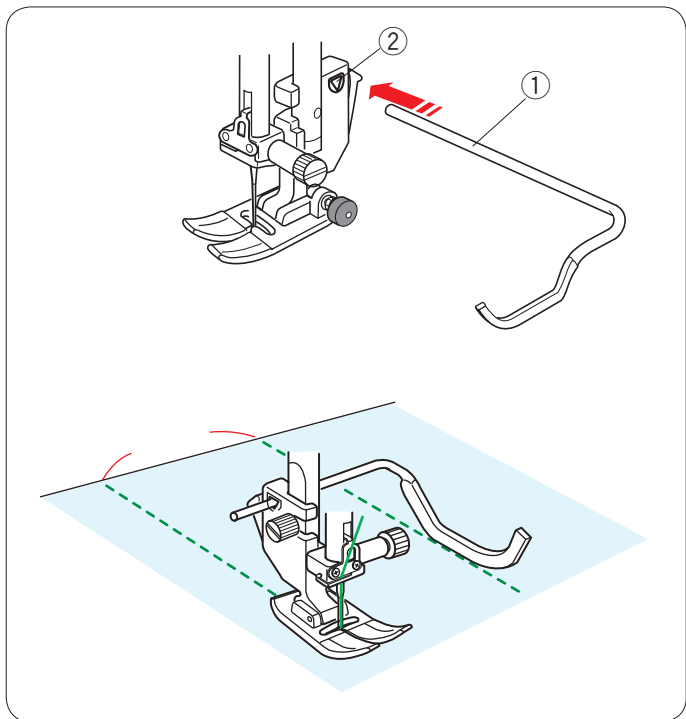

Q1-Q3 Patchwork piecing

Patterns Q1 to Q3 are special stitches for seaming patchwork pieces.

Patterns Q2 and Q3 are for patchwork piecing with 1/4" and 7 mm seam allowances respectively.

Use the 1/4" seam foot O.

Place the patchwork pieces right sides together. Sew while guiding the edge of fabric along the guide.

- ① Guide

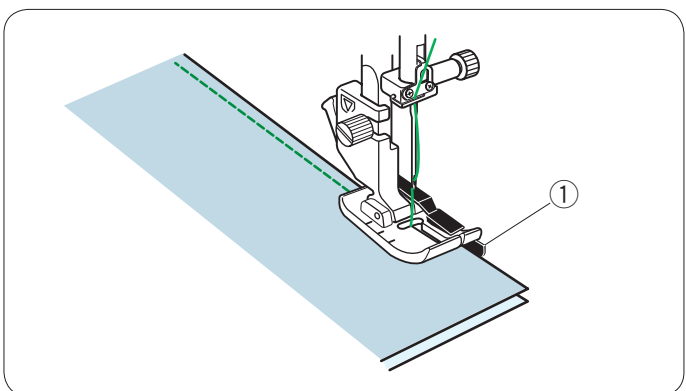

Q43-Q46 Hand-look quilt stitches

Patterns Q43 to Q46 are special stitches for quilting which look like hand sewn stitches.

Use a transparent nylon thread for the needle and ordinary sewing thread for the bobbin.

The bobbin thread is pulled up on the right side of the fabric and the stitches look as if they were sewn by hand.



S1-S12 Decorative satin stitches

Patterns S1 to S12 are decorative satin stitches for which the pattern length can be elongated without changing the stitch density.

Press the adjust key to open the manual setting window.

① Adjust key

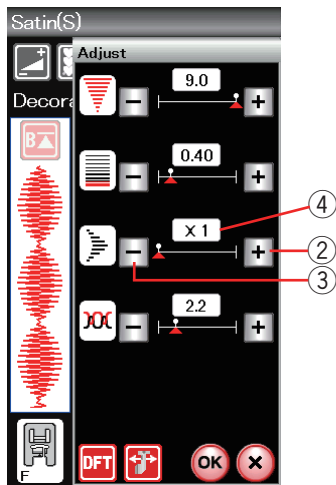
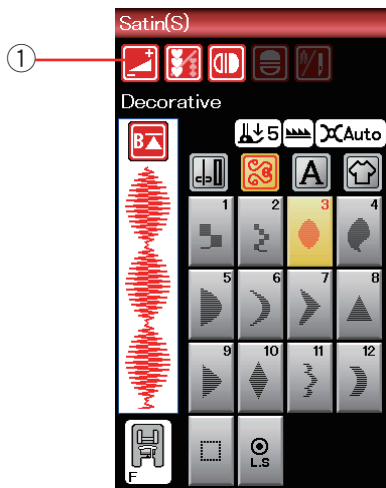

Press the “+” key to elongate the stitch pattern.

② “+” key (elongation)

To reduce the elongation ratio, press the “-” key.

③ “-” key (elongation)

Press the OK key to register the elongation ratio.

The pattern can be elongated up to 5 times the original length.

The elongation ratio is indicated in the box.

④ Elongation ratio

You can also alter stitch density and stitch width.

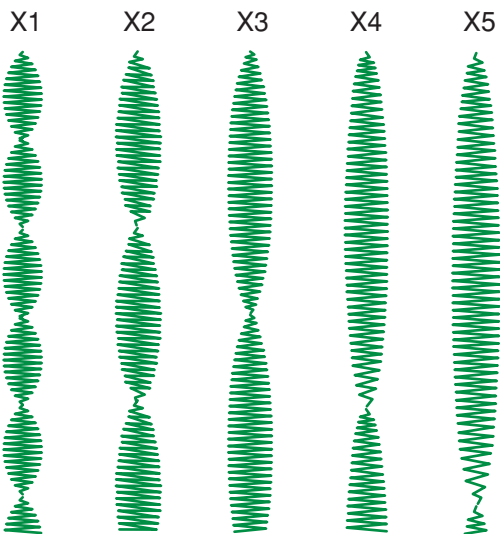

Twin Needle Sewing

Some of the utility stitches and decorative stitches can be sewn with a twin needle.

Replace the needle with the twin needle supplied with the standard accessories.

CAUTION:

Turn the power switch off or press the lockout key before changing the needle.

Do not use twin needles other than the one included in the standard accessories, otherwise the needle may hit the needle plate, foot or hook and break.

① Lockout key

Insert the extra spool pin into the hole (refer to page 10). Place a spool of thread on the extra spool pin and fix the spool with the spool holder.

② Extra spool pin

Draw both threads from the spools and pass them through the threading points from ① to ⑦.

Make sure that the two strands of thread from the spools do not get tangled.

NOTE:

Threading from points ① to ⑤ is the same as for a single needle (refer to page 13).

Slip one of the threads through the needle bar thread guide on the left, and the other one on the right.

Thread the needles from front to back.

NOTE:

The needle threader cannot be used with the twin needle.

Press the twin needle key and select the desired pattern.

Patterns not suitable for twin needle sewing cannot be selected (pattern selection keys are grayed out).

Buttonholes and specialty stitches, monogram and sewing application cannot be selected.

③ Twin needle key

NOTES:

- When you sew patterns with the twin needle, test the stitches first before you sew on the garment.
- Use the zigzag foot A or satin stitch foot F for twin needle sewing.
- Use thread #60 or finer.
- When changing the sewing direction, raise the needle and presser foot then turn the fabric.
- Use the thread cutter on face cover plate when cutting threads.

After twin needle sewing is finished, press the twin needle key and the warning message will appear.

Press the OK key, and replace the twin needle with a single needle.

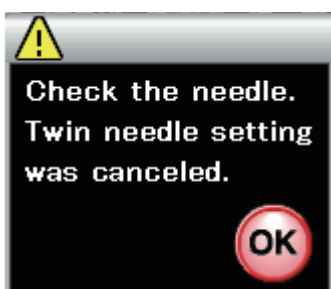
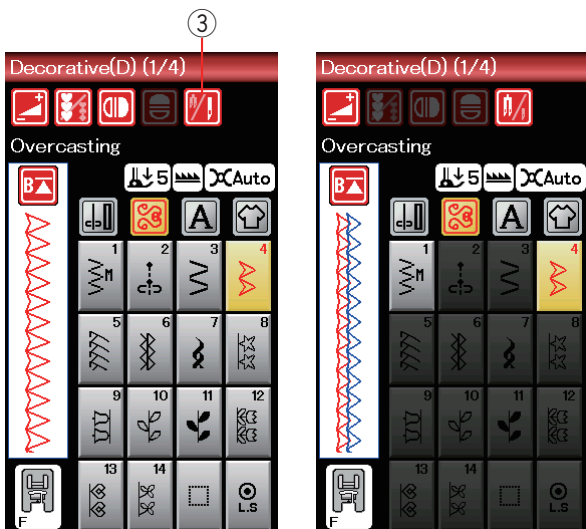
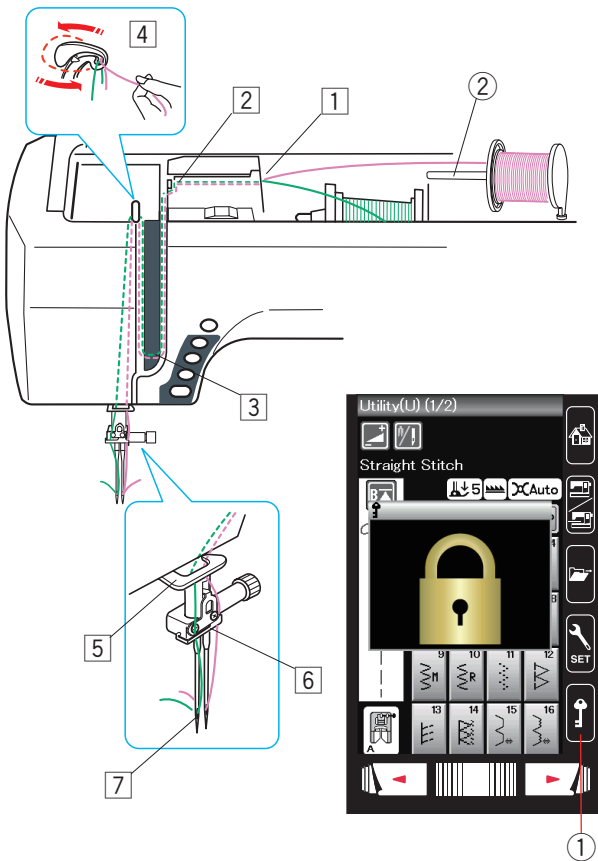

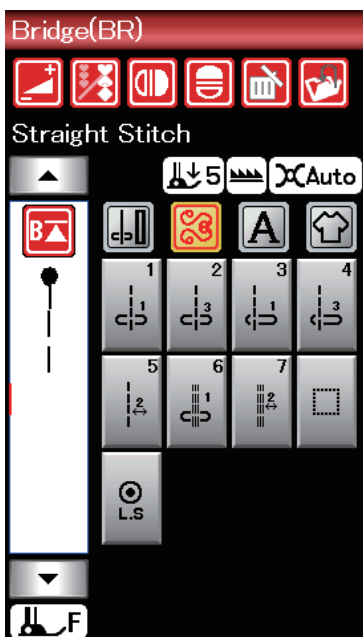
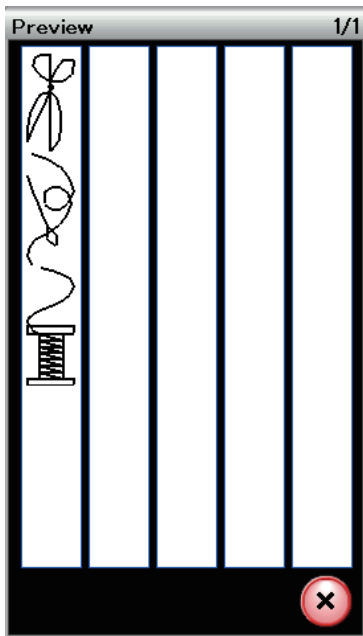
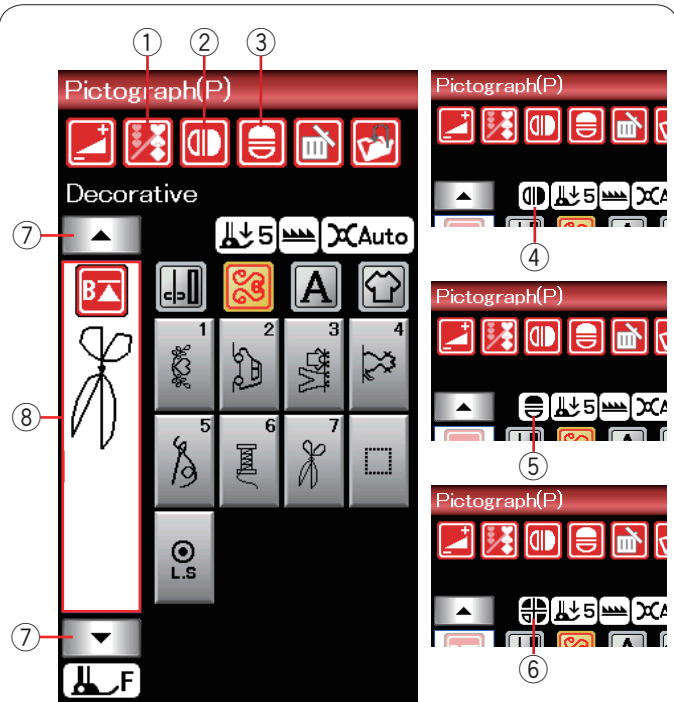

Programming a Pattern Combination

The patterns in the decorative stitch category and monograms can be programmed to make a pattern combination.

Press the program key and select as many patterns as you wish to program.

The images of programmed patterns are shown on the left side of the visual touch screen.

- ① Program key

Mirror image of patterns

To sew or program the pattern as a mirror image, press the vertical mirror key or horizontal mirror key.

Mirror image icon appears on the screen and mirror image function is enabled.

Select the desired patterns to create the mirror image.

Press the vertical or horizontal mirror image key again to cancel the mirror image function.

- ② Vertical mirror key
- ③ Horizontal mirror key
- ④ Vertical mirror icon
- ⑤ Horizontal mirror icon
- ⑥ Vertical and horizontal mirror icon

NOTES:

- Horizontal mirror image is available only for specific patterns. For pattern identification, these patterns are shaded in pink on the reference chart inside the top cover.

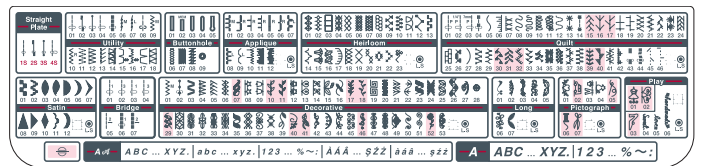

- Mirror image function will be canceled and mirror image icon disappear if the selected pattern is not suitable for the mirror image.

To view the entire pattern combination, press the cursor key to scroll over the pattern combination or press the edit box to show the entire pattern combination at a glance.

- ⑦ Cursor keys
- ⑧ Edit box

Bridge Stitches

Bridge stitches are used for inserting straight stitches after a stitch pattern.

If you want more space between French knots (D2), for example, insert pattern BR5 after pattern D2.

Two counts of straight stitches are added to pattern D2.

NOTE:

Patterns BR5 and BR7 will inherit the stitch length and needle drop position of the previous pattern in the pattern combination.

Editing a pattern combination

Deleting the pattern

The pattern before the cursor or shown in red is deleted by pressing the delete key.

- ① Cursor
- ② Delete key

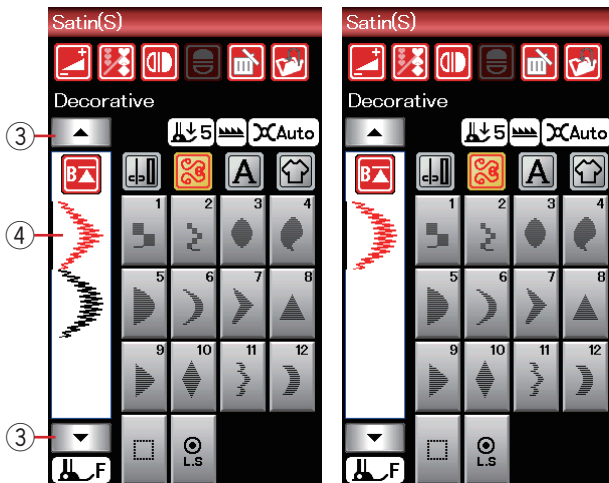
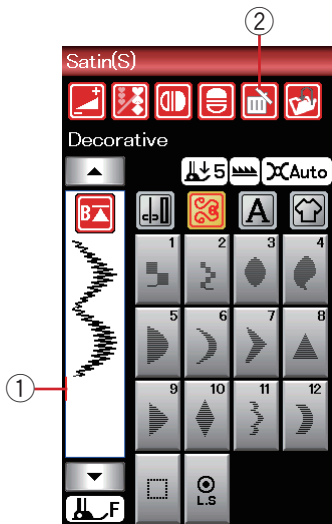

To delete a pattern in the middle of a combination, press the cursor key to select the pattern you wish to delete.

The stitch image of the selected pattern turns red. Press the delete key to delete the selected pattern.

- ③ Cursor key
- ④ Selected pattern

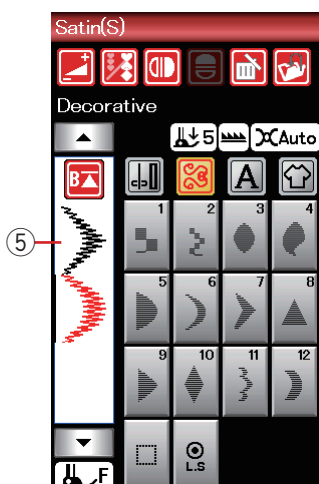

Inserting the pattern

Press the cursor key to select the pattern next to where you wish to insert a pattern. Enter the desired pattern to insert it before the selected pattern.

- ⑤ Inserted pattern

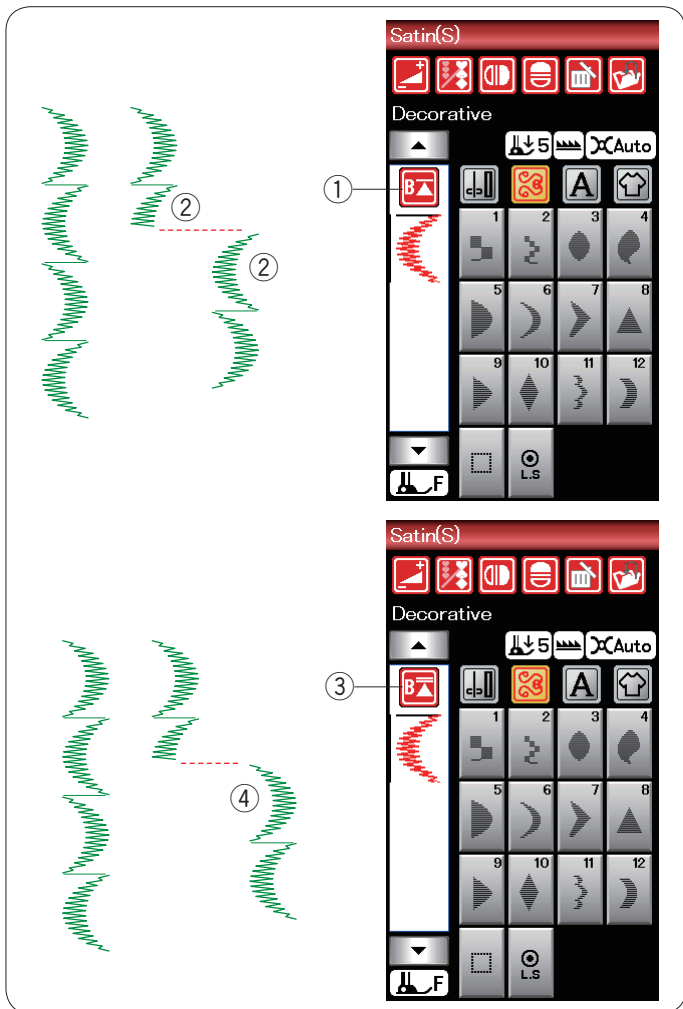

Startover key

This is a 2-way function key to start sewing a pattern combination over from the beginning.

When you stop sewing a pattern combination, the startover key is activated.

The key shows a triangle and single bar that means the machine will start over from the current pattern.

When you press the startover key, the key will change and show a triangle and double bar that means the machine will start over from the first pattern of the combination.

Current pattern startover

If you wish to start sewing from the beginning of the current pattern, press the startover key once and start the machine.

- ① Startover key (current pattern)
- ② Current pattern

First pattern startover

If you wish to start sewing from the beginning of the first pattern of the combination, press the startover key twice and start the machine.

- ③ Startover key (first pattern)
- ④ First pattern

NOTE:

If auto thread cutting is done, the machine will startover from the first pattern.

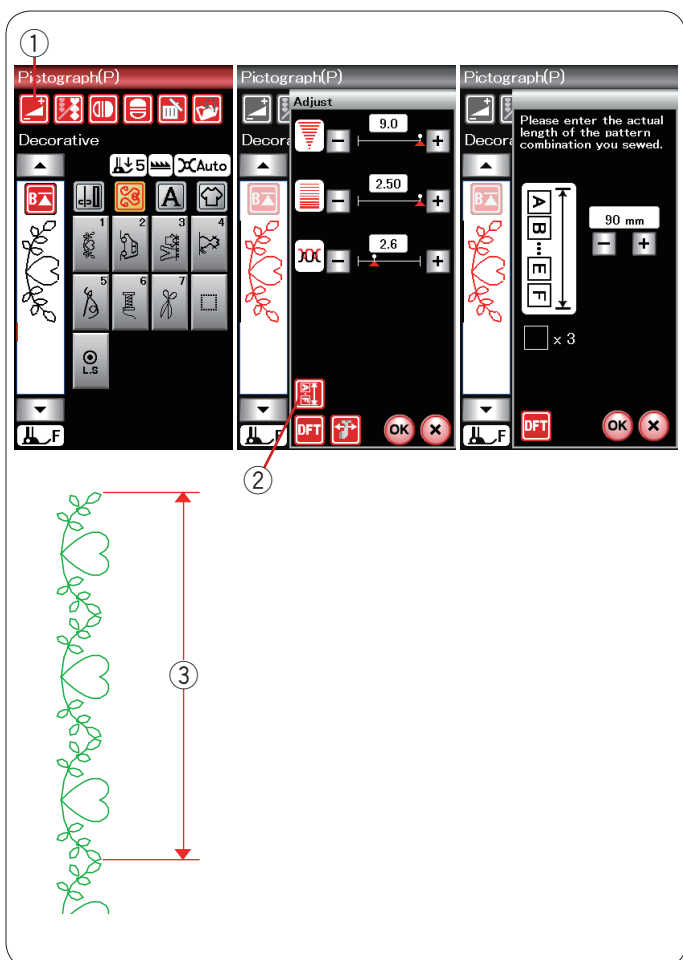

Checking pattern combination length

You can check the total length of the pattern combination by pressing the pattern combination key ② indicated in the manual setting window. To enter the manual setting window, press the adjust key ①.

The readout of the total length is a theoretical value and the actual length may vary depending on sewing conditions.

For example, program pattern P1 three times, and sew a pattern combination.

If the actual length differs considerably from the readout, measure the actual length and enter the nearest value by pressing the "+" or "-" key.

- ③ Actual length

The readout is adjusted automatically when calculating the length of other pattern combinations (combination of patterns P1 X 3 for example).

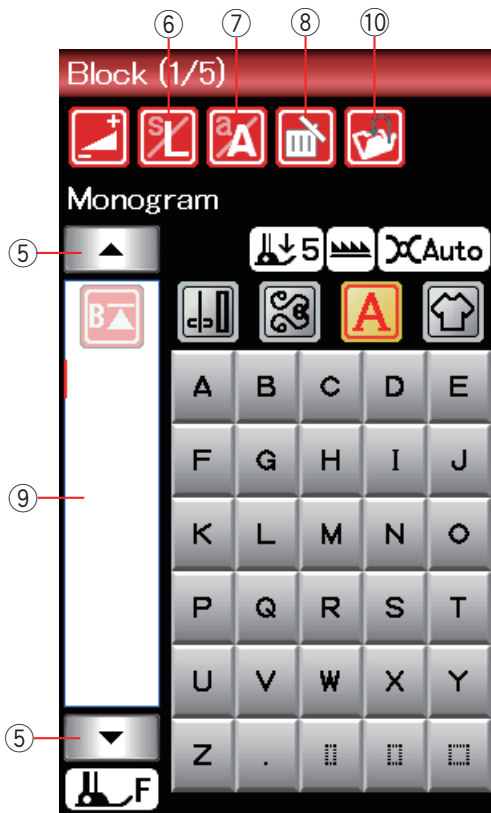
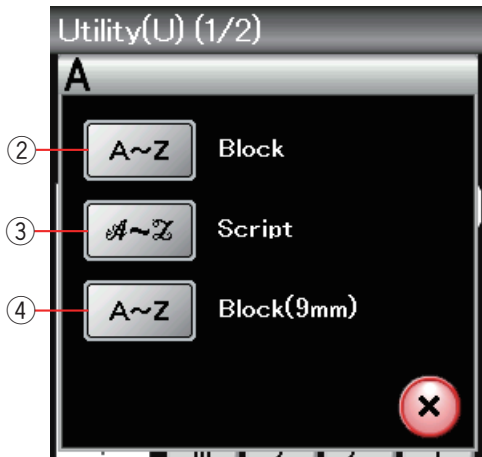
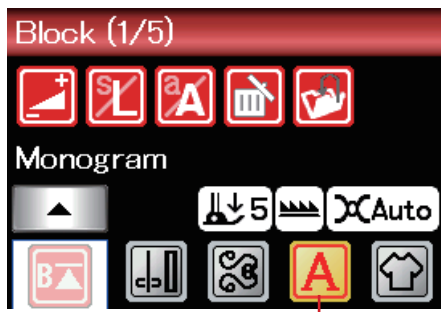

Monogramming

You can program letters for monogramming.

Press the monogram key and the font selection window will open.

- ① Monogram key

You can select one of 3 fonts.

Select the desired font by pressing the corresponding key.

- ② Block font key
- ③ Script font key
- ④ Block font key (9 mm)

The monogram mode window will open.

Function keys

- ⑤ **Cursor key**

Press the cursor key to move the cursor up or down.

- ⑥ **Letter size key**

Press this key to select the full size (L) or small size (S).

- ⑦ **Letter case key**

Press this key to select the upper case or lower case.

- ⑧ **Delete key**

Press this key to delete the selected character.

- ⑨ **Edit box**

Press the edit box to view the entire monogram.

- ⑩ **File save key**

Press this key to save the monogram as a data file.

NOTE:

Numbers, signs and European letters are available on pages 2/5 through 5/5.

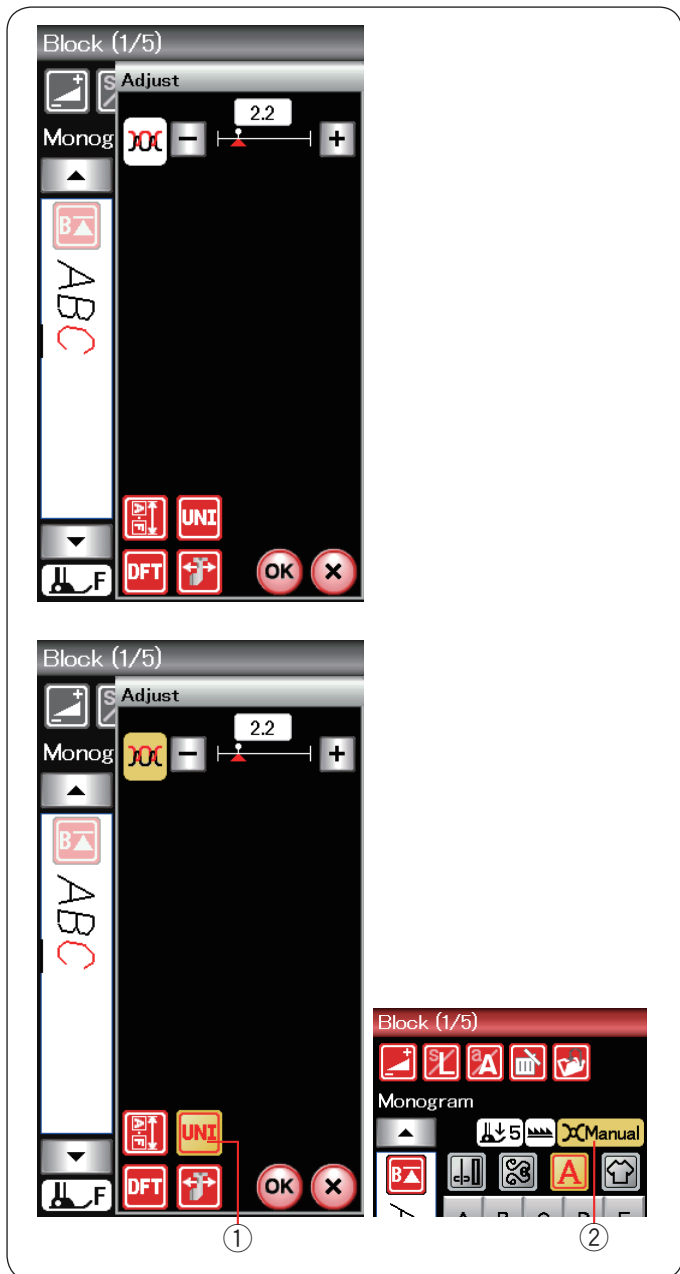

Manual thread tension

This machine is equipped with automatic thread tension control. However, you may need to manually adjust the tension balance depending on the sewing conditions.

To adjust the thread tension, press the adjust key to open the manual setting window.

Individual thread tension adjustment

To apply the thread tension adjustment to each letter individually, select the letter by moving the cursor. Press “+” or “-” to adjust the thread tension of the selected letter. The adjusted thread tension is applied to the selected letter.

Unified thread tension adjustment

To apply the thread tension adjustment to all letters together, you do not need to select the letter.

Press the unified thread tension key ①. The key turns orange when activated.

Press “+” or “-” to adjust the thread tension.

Press OK key. The adjusted thread tension is applied to all entered letters.

When unified thread tension control is applied, the thread tension window turns to orange ②.

NOTE:

Unified thread tension adjustment can be applied monogram patterns only.

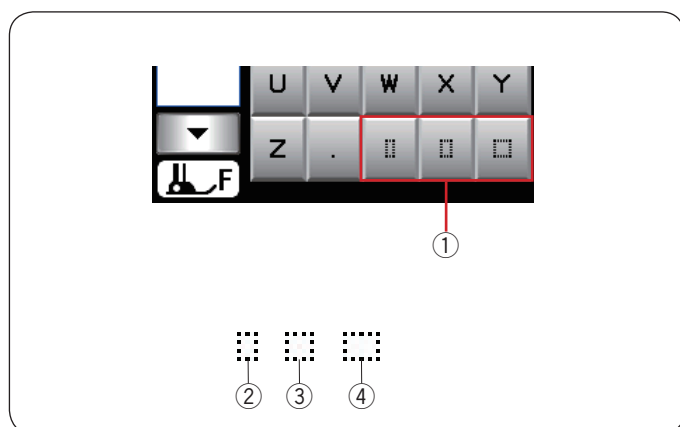

Spacing

To enter a space in monogramming, press one of the three space keys on the lower right corner of the monogram selection.

- ① Space keys
- ② Small-size space
- ③ Medium-size space
- ④ Large-size space



Reducing the size of letters

To reduce the height of a character to approximately 2/3 of its original size, select the character and press the letter size key ①.

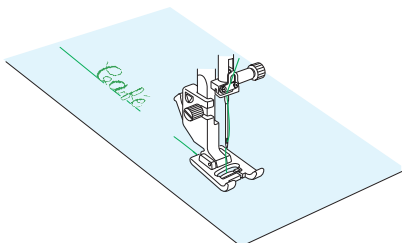
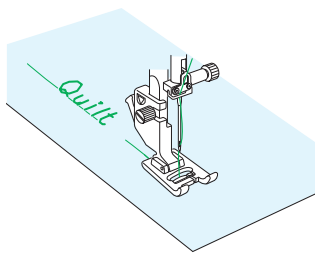
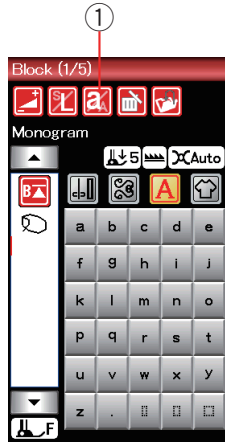
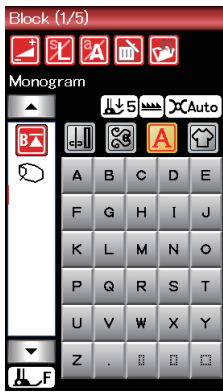

Programming a monogram

Simply enter the characters by pressing the corresponding keys to program a monogram.

Example 1: “Quilt” in Block font

Select Block font. Enter “Q”.

Press the letter case key to select lower case.

- ① Letter case key

Enter “u”, “i”, “l” and “t”.

Example 2: “Café” in Script font

Press the monogram key and select Script font.

Enter “C”.

Press the letter case key and select lower case letters.

Enter “a” and “f”.

Press the next page key to go to page 4 of 5.

Enter “é”.

NOTES:

Use a blue tip needle for sewing a monogram.

Apply a tear away backing to fine fabrics or stretch fabrics.

Test sew to check the sewing results.

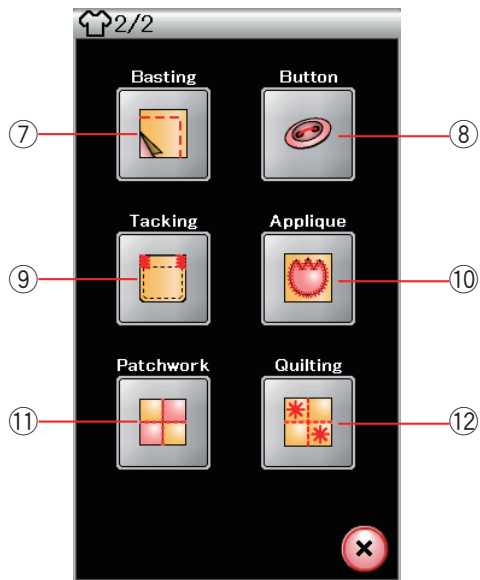
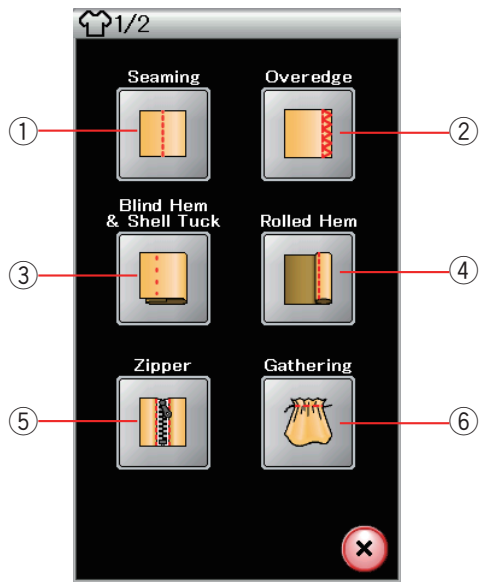

Sewing Application

Sewing application is a unique feature that provides you with 12 useful sewing applications.

Press the sewing application key and the sewing application menu will open. Press the next page key to show the second page of the menu.

The 12 sewing applications are as follows:

- ① Seaming
- ② Overedge
- ③ Blind Hem & Shell Tuck
- ④ Rolled Hem
- ⑤ Zipper Sewing
- ⑥ Gathering

- ⑦ Basting
- ⑧ Button Sewing
- ⑨ Tacking
- ⑩ Applique
- ⑪ Patchwork
- ⑫ Quilting

Seaming

There are 4 types of stitches for seaming in this group.

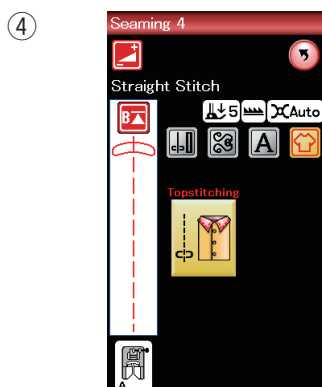
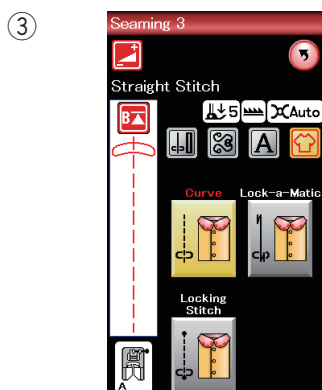
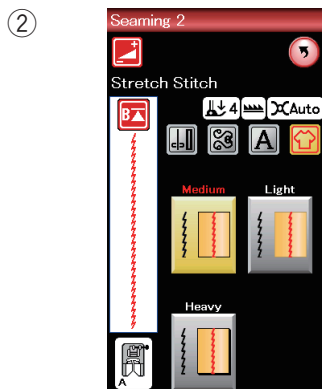
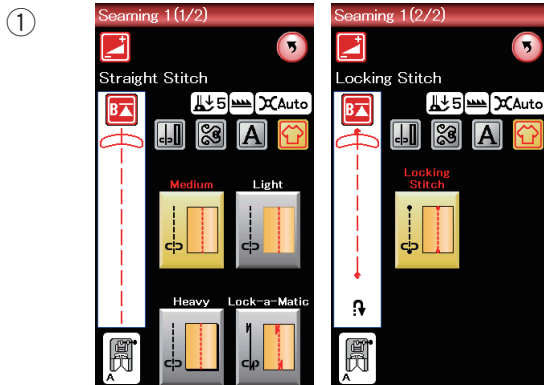
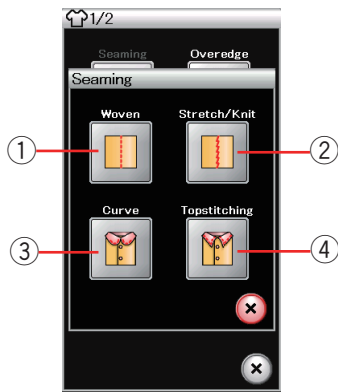

① Woven

Straight stitches for seaming regular woven fabrics.

② Stretch/Knit

Narrow stretch stitches for seaming stretch or knit fabrics.

③ Curve

Short straight stitches for seaming curved lines.

④ Topstitching

Long straight stitch for topstitching with thick threads.

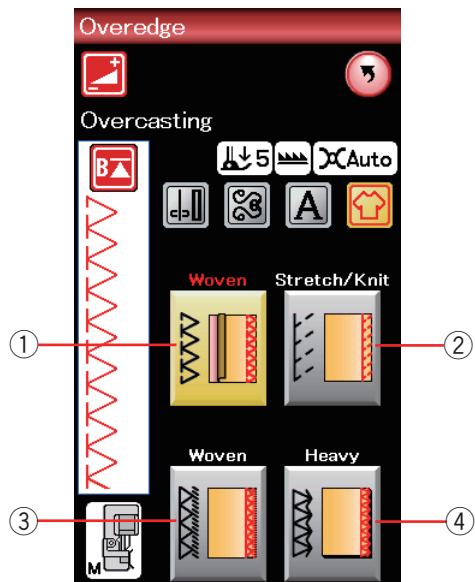

Overedge

① Woven

Overcasting stitch for regular woven fabrics.

② Stretch/Knit

Knit stitch for finishing raw edges of stretch or knit fabrics.

③ Woven

Overlock stitch similar to a professional overlocker stitch.

④ Heavy

Double overedge stitch for preventing raw edges of linens and gabardines from ravelling.

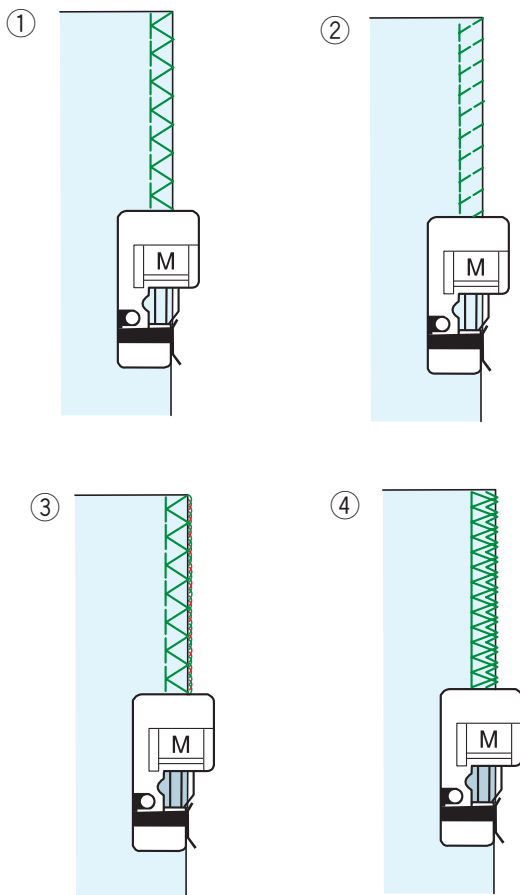

Refer to page 31 for how to sew.

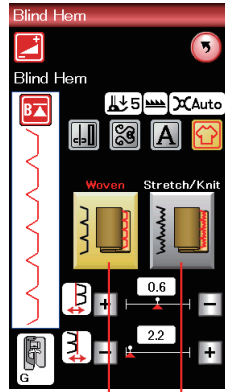
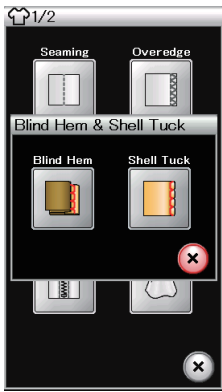

① ②

(A)

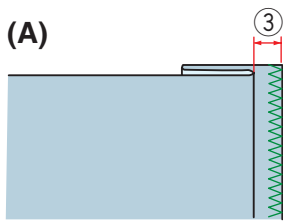

(B)

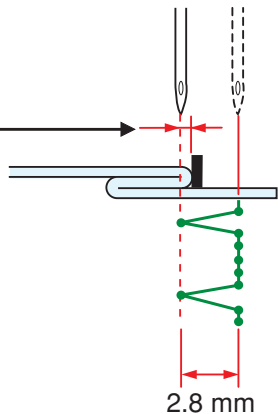
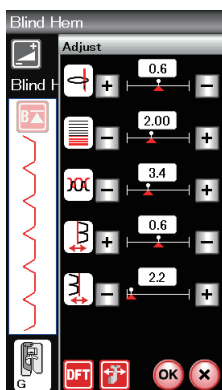
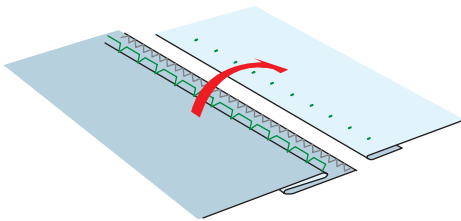
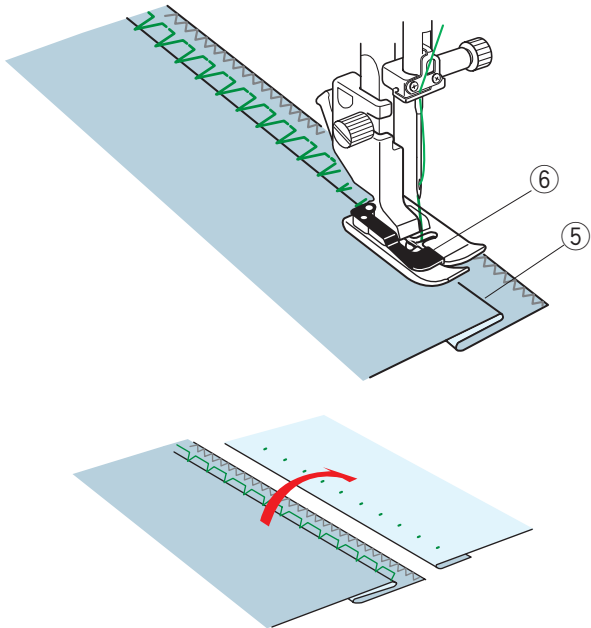
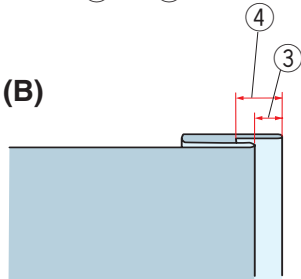

Blind hem

Select "Blind Hem".

The following 2 options are available.

① Woven

For blind hemming regular woven fabric

② Stretch/Knit

For blind hemming stretch or knit fabric.

To sew:

Attach the blind hem foot G.

Fold the fabric to form a hem leaving a 0.5 cm (1/4") allowance as shown.

③ 0.5 cm (1/4")

(A) Medium to heavy fabrics: The raw edge should be overcasted.

(B) Fine fabrics: Fold the raw edge 1 cm (1/2").

④ 1 cm (1/2")

Position the fabric so that the fold comes to the left side of the guide on the foot. Lower the presser foot.

The needle should just pierce the folded edge when it comes over to the left side.

Adjust the position of the needle drop if necessary.

Sew guiding the fold along the guide.

⑤ Fold

⑥ Guide

After sewing is finished, open the fabric flat.

The seam on the right side of the fabric is almost invisible.

Adjusting the needle drop position

Press the adjust key to open the manual setting window.

Press the "+" key in the upper row to move the needle drop positions to the left.

Press the "-" key in the upper row to move the needle drop positions to the right.

Press the OK key to register the settings.

The needle drop position will change, while the stitch width (2.8 mm) remains consistent.

The distance between the left needle drop position and guide of the foot is indicated in millimeters.

NOTE:

You can alter the stitch width by changing the right needle drop position.

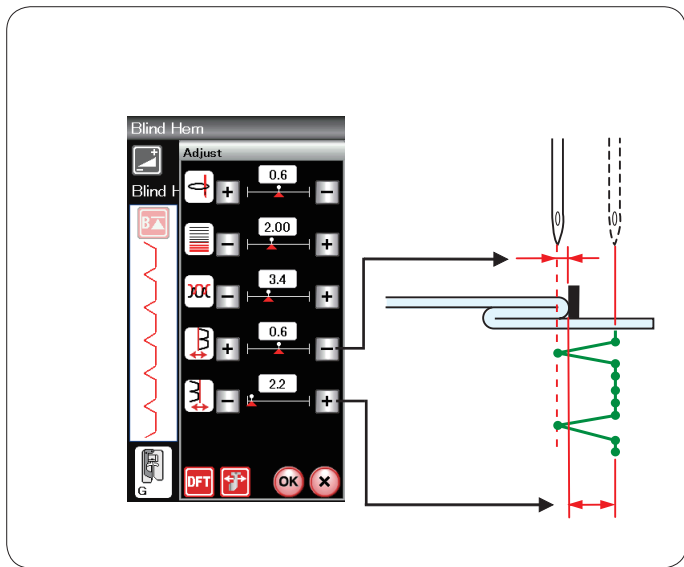

Altering blind hem stitch width

Press the “+” key in the lower row to increase the stitch width.

Press the “-” key in the lower row to decrease the stitch width.

NOTE:

You can move the left needle drop position with the “+” or “-” key in the upper row.

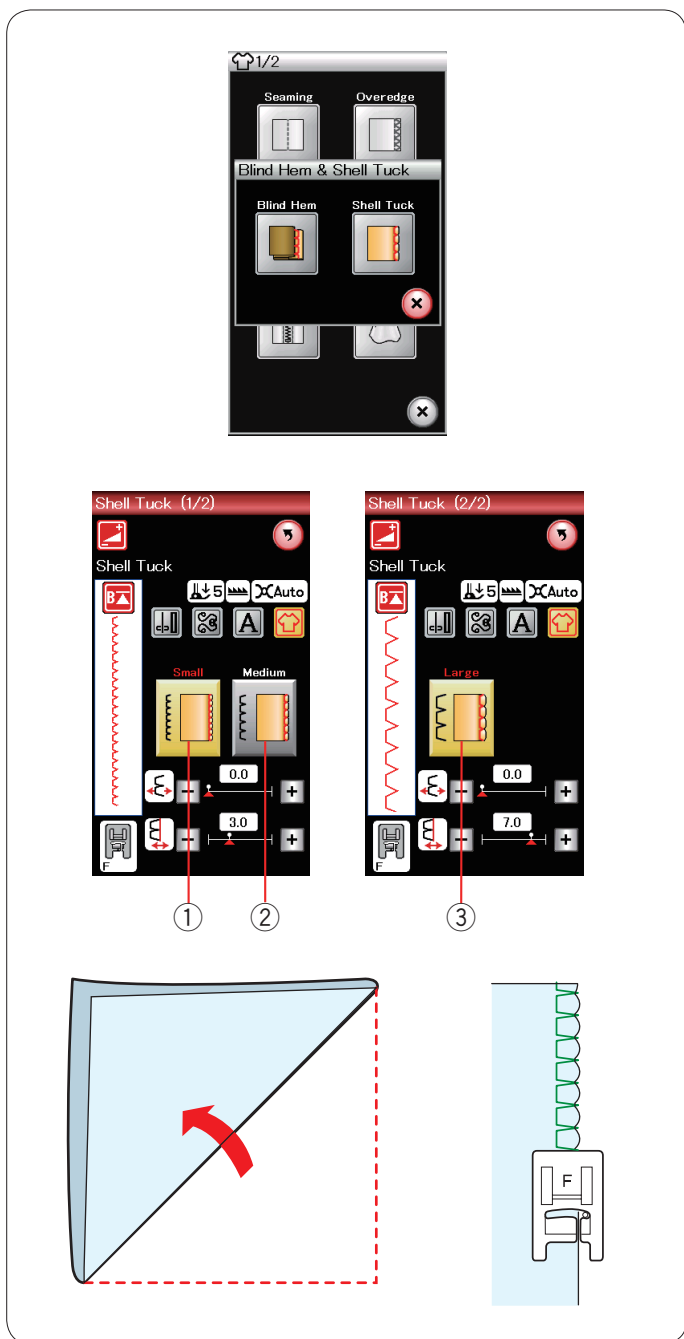

Shell tuck

Select “Shell Tuck”.

The following 3 options are available.

- ① Small
Narrow shell tuck stitch
- ② Medium
Medium width shell tuck stitch
- ③ Large
Regular shell tuck stitch

To sew:

Use a light weight fabric (Tricot, for example).
Fold the fabric in bias as shown and stitch on the fold.

Allow the needle to barely clear the folded edge to create a shelled edge.

If you sew shell tucks, space the rows at least 1.5 cm (5/8”) apart.

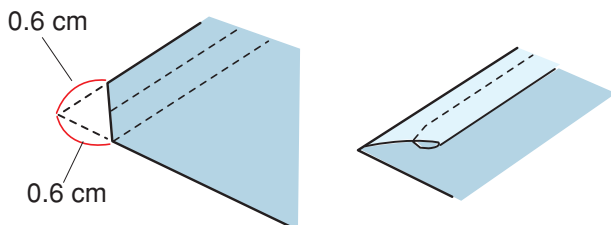
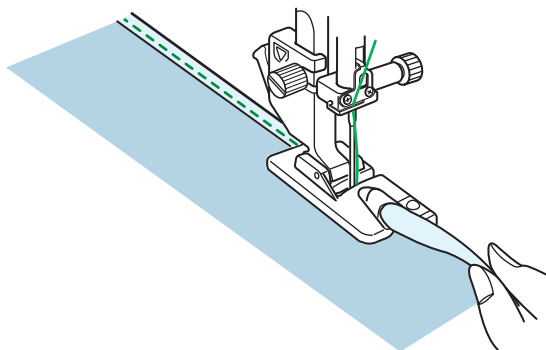
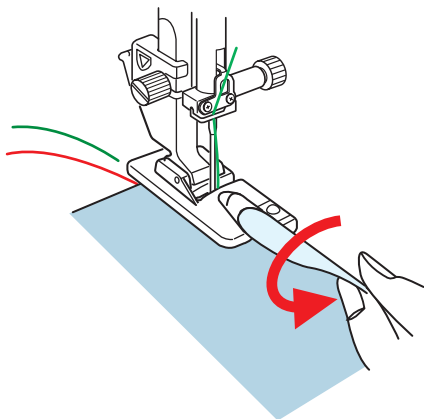
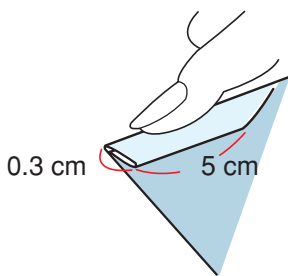
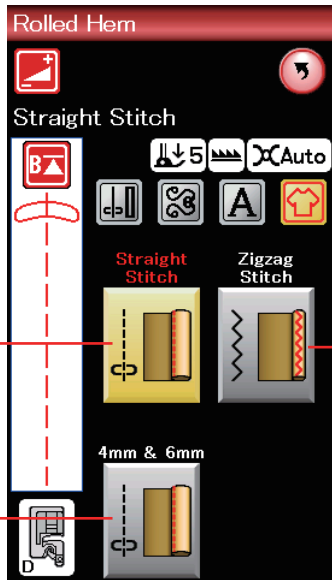

Rolled hem

- ① Straight Stitch
Rolled hemming with straight stitch
- ② Zigzag Stitch
Rolled hemming with narrow zigzag stitch
- ③ 4 mm & 6 mm (optional)
Rolled hemming using optional rolled hemming feet D1 and D2

To sew:

Attach the rolled hem foot D.

Fold the fabric edge twice to form a hem, 0.3 cm (1/8") wide and 5 cm (2") long then press as shown.

Place the fabric aligning the hem edge with the guide of the foot. Turn the hand wheel to lower the needle to the starting point.

Lower the foot and sew several stitches slowly while pulling on the threads to assist feeding the fabric.

Stop the machine and lower the needle into the fabric. Raise the foot and insert the folded portion of the fabric into the curl of the foot.

Lower the foot and sew while lifting the edge of the fabric to keep it feeding into the curl smoothly and evenly.

NOTE:

Trim the corners 0.6 cm (1/4") to reduce bulk.

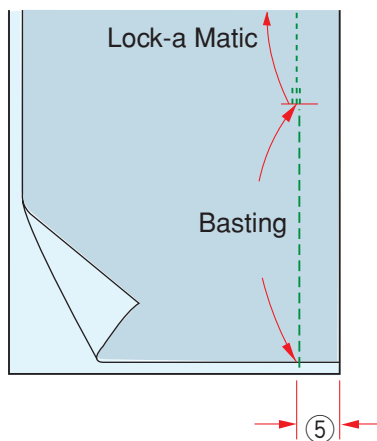
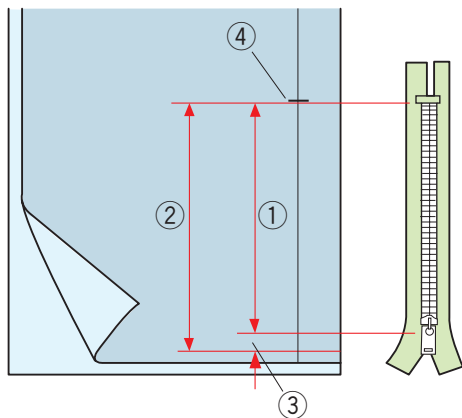
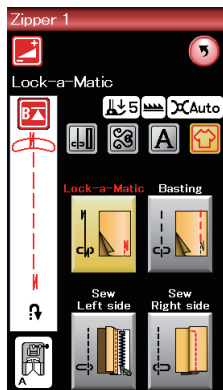
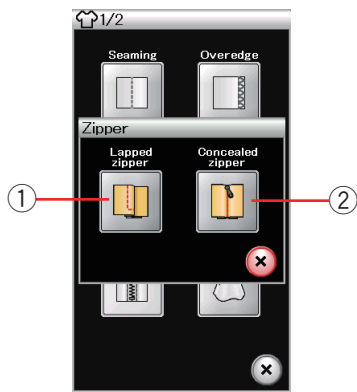

Zipper sewing

① Lapped zipper

Lapped zipper application with zipper foot E

② Concealed zipper (optional)

Concealed zipper application using optional concealed zipper foot Z.

Lapped zipper sewing

Press the lapped zipper icon and the zipper sewing window will open.

Press the sewing step icon so the machine setting will be automatically suited for each sewing step.

Fabric preparation

Add 1 cm (3/8") to the zipper size. This is the overall opening size.

Mark the end of opening.

- ① Zipper size
- ② Opening size
- ③ 1 cm (3/8")
- ④ End of opening

Attach zigzag foot A.



Lock-a-Matic

Place the right sides of the fabric together and sew to the end of the opening leaving a 2 cm (3/4") allowance.

- ⑤ 2 cm (3/4")



Basting

Baste the zipper opening.



Sew left side

Attach zipper foot E.

Fold back the left seam allowance. Turn the right seam allowance under to form a 0.2 to 0.3 cm (1/8") fold.

Place the zipper teeth next to the fold and pin in place.

- ① 0.2-0.3 cm (1/8")
- ② Zipper teeth
- ③ Fold

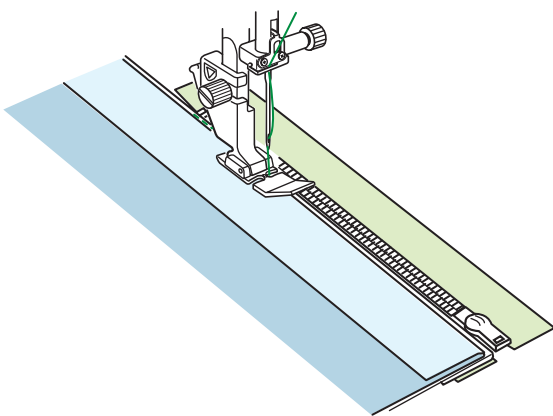
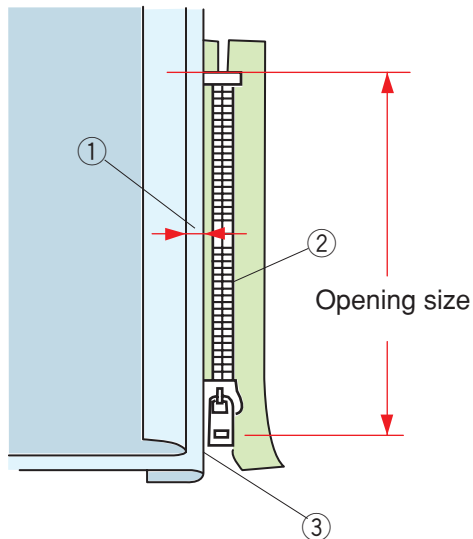

Lower the foot onto the topside at the bottom of the zipper so that the needle pierces the fabric next to the fold and the zipper tape.

Sew along the zipper guiding the zipper teeth along the bottom edge of the foot.

Sew through all layers next to the fold.

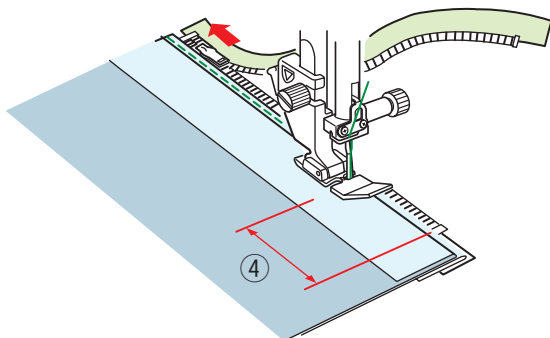

Stop 5 cm (2") before zipper foot E reaches the slider on the zipper tape.

- ④ 5 cm (2")

Raise the foot and open the zipper. Lower the foot and stitch the remainder of the seam.

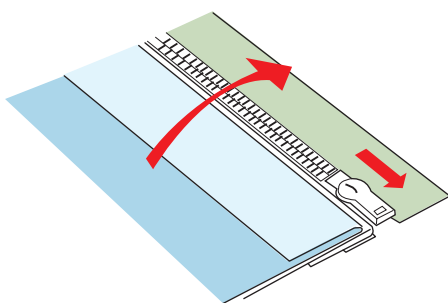

Close the zipper and spread the fabric open flat with the right side of the fabric facing up.

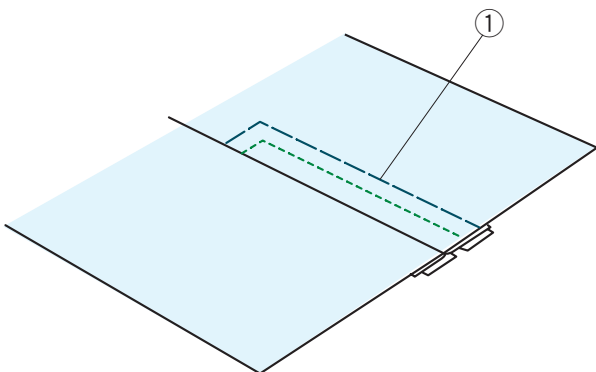
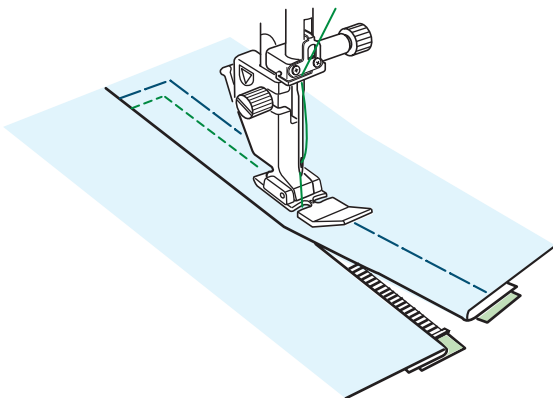
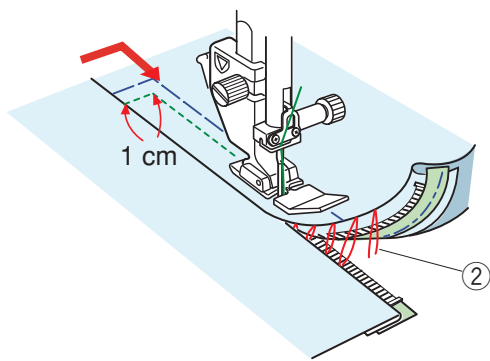
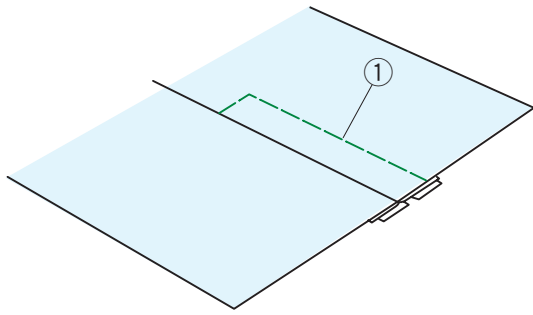

Basting

Replace the foot with zigzag foot A.
Baste the opened fabric and zipper tape together.

① Basting

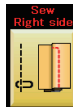

Sew right side

Replace the foot with zipper foot E.
Backstitch across the end of opening to 1 cm (3/8").
Stitch through the garment and zipper tape, guiding the zipper teeth along the bottom edge on the foot.
Stop about 5 cm (2") from the top of the zipper.
Lower the needle into the fabric, raise the foot and remove the basting stitches.

② Basting stitches

Open the zipper and move the slider to the rear of the foot.

Lower the foot and stitch the remainder of the seam making sure the fold is even.

Remove the basting stitches.

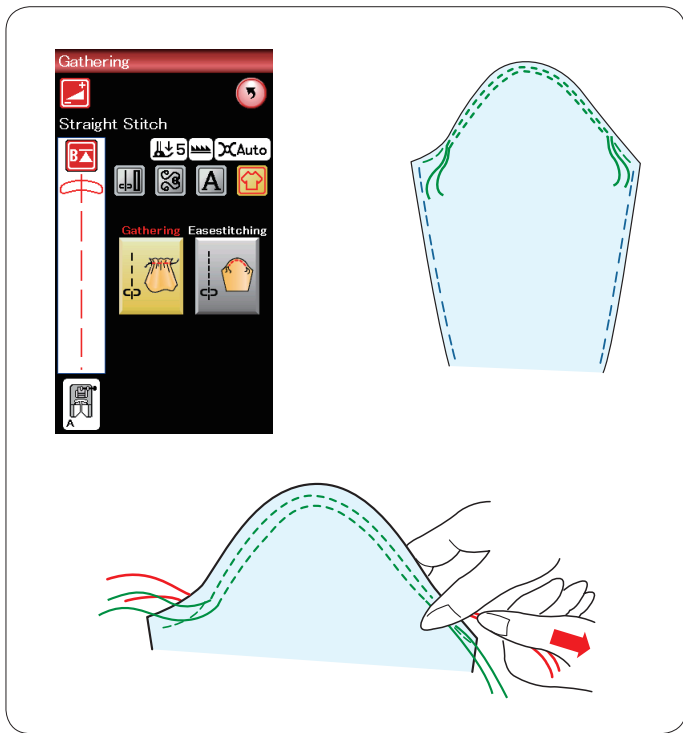

Gathering

In addition to the regular gathering stitch, this section offers you a special stitch for easing sleeve tops.

Easing a sleeve top

Draw the bobbin thread up (refer to page 15). Sew a pair of lines, 3 mm (1/8") apart, along the edge of the sleeve top.

Pull the bobbin threads to contract the sleeve top carefully, matching it with the armhole size.

Make sure not to make gathers in the sleeve top.

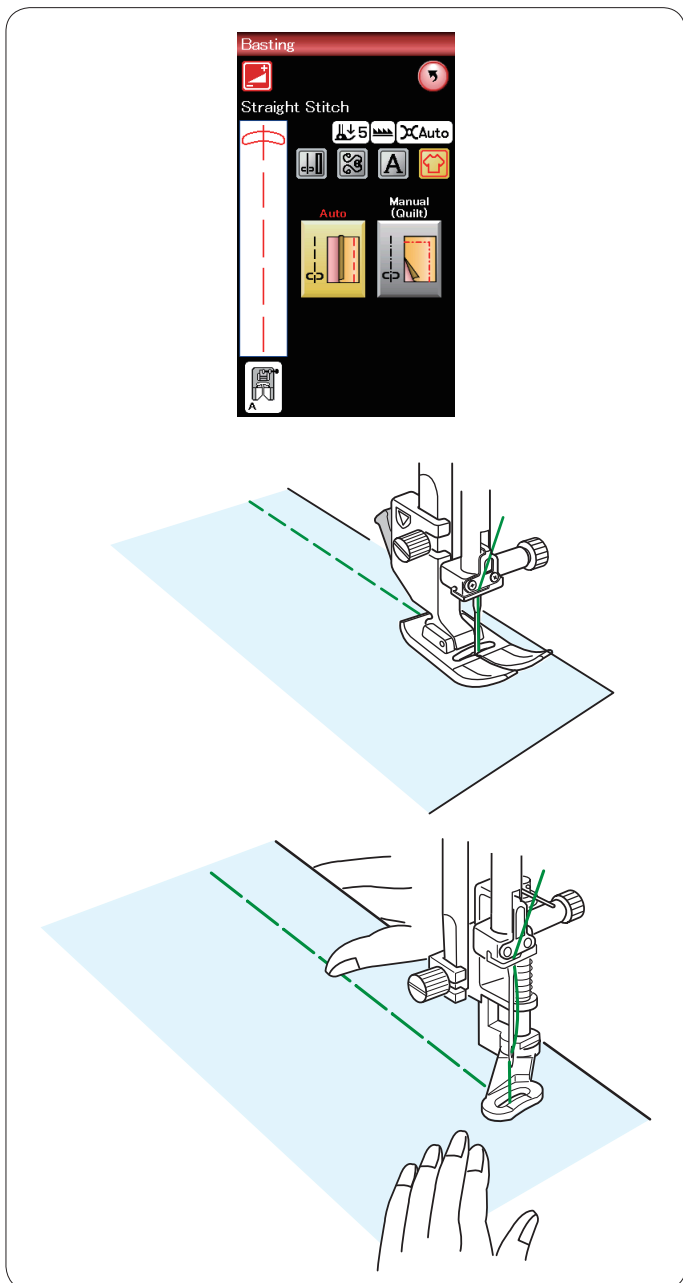

Basting

There are 2 basting stitches available in this section.

Basting (Auto)

This stitch is used for basting zipper tape or fitting of garments.

Sew in the same way as that for straight stitch sewing.

Basting (Manual/Quilting)

Attach darning foot PD-H.
Lower the feed dog.

NOTE:

Refer to page 18 for how to attach darning foot PD-H.

To sew

Hold the fabric taut and depress the foot control.
The machine will make one stitch and stop automatically.

Slide the fabric to the rear for the next stitch.

Button sewing

When attaching a button to thick fabric, you need to make a shank by using the button shank plate. Select “Shank”. Lower the feed dog.

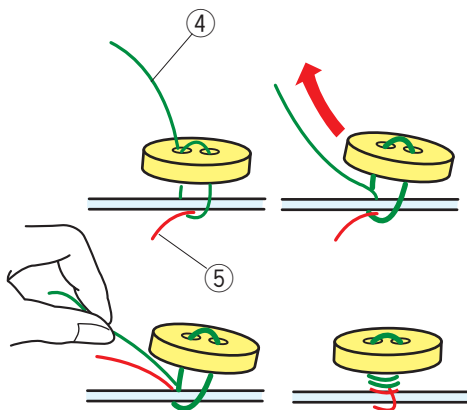
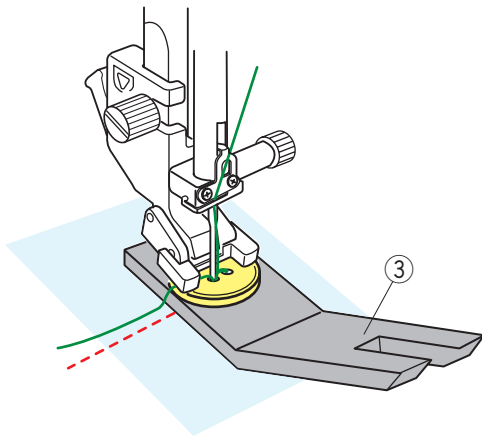
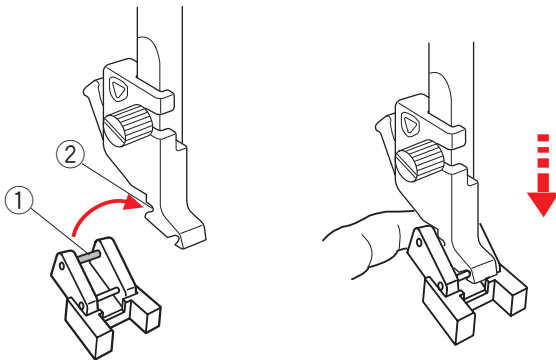
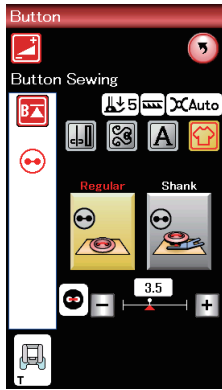

Attaching button sewing foot T

Make sure to press the lockout key to lock the machine. Insert the rear pin of the foot into the rear groove of the foot holder.

- ① Rear pin
- ② Rear groove

Gently lower the presser foot lifter while holding the foot with your finger to fit the foot. Press the lockout key to unlock the machine.

Place a button on the fabric and lower the needle into the left hole of the button by turning the handwheel with your hand.

Insert the button shank plate under the button. Lower the foot to hold the button in place, aligning the direction of the button.

- ③ Button shank plate

Raise the needle by turning the handwheel until the needle bar swings to the right.

Press the “+” or “-” key so the needle enters into the right hole of the button.

Start sewing and continue until the machine stops automatically.

Remove the fabric from the machine.

Cut the all threads leaving at least 10 cm (4”) tails. Trim the threads at the beginning close to the fabric.

Pass the needle thread at the end of stitching through the left hole in the button, between the button and fabric. Pull the needle thread to bring the bobbin thread up to the right side of the fabric.

- ④ Needle thread at the end
- ⑤ Bobbin thread

Wind the threads to form a shank and knot them together.

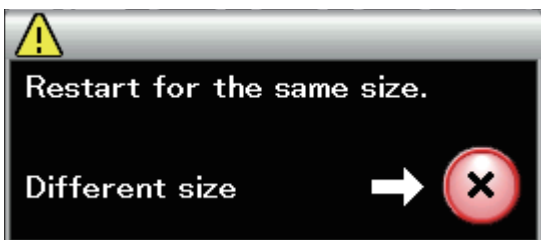
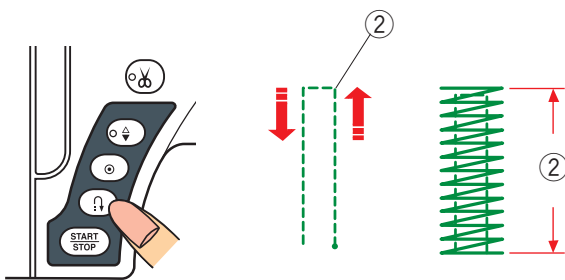
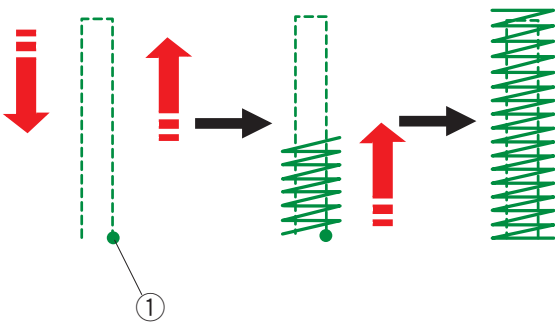
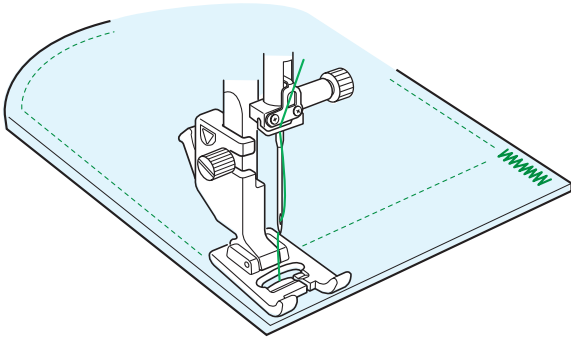
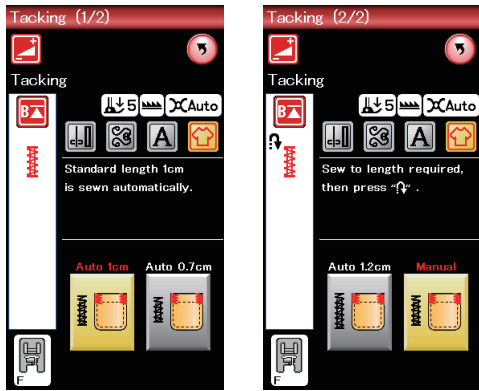

Tacking

Tacking is used to reinforce pockets, crotches and belt carriers where extra strength is needed.

There are 3 auto tacking sizes and manual tacking available.

Attach satin stitch foot F.

Auto tacking

Lower the needle at the starting point and start sewing. The machine will sew the tack of the selected size and stop automatically when it is finished.

- ① Starting point

Manual tacking

Start the machine and sew to the required length, then press the reverse button. This sets the tack length. Continue sewing until the machine stops automatically.

- ② Required length

NOTE:

The maximum length of tacking is 1.5 cm (5/8").

To sew the same size tack

To sew another tack in the same size, simply start the machine and sew until the machine stops automatically.

To sew the next tack in a different size, press the X key.

Applique

There are 6 types of applique stitches available in this section.

You can select the needle stop position either up or down by pressing the needle stop position key.

- ① Needle stop position key

The letter above the stitch image denotes the baseline of the needle drop position.

M: Middle (center)

R: Right

The baseline can be adjusted without changing the stitch width by pressing the “+” or “-” key on the bottom row.

NOTE:

Make sure to stop the machine with the needle dropped at the outer edge of the applique.

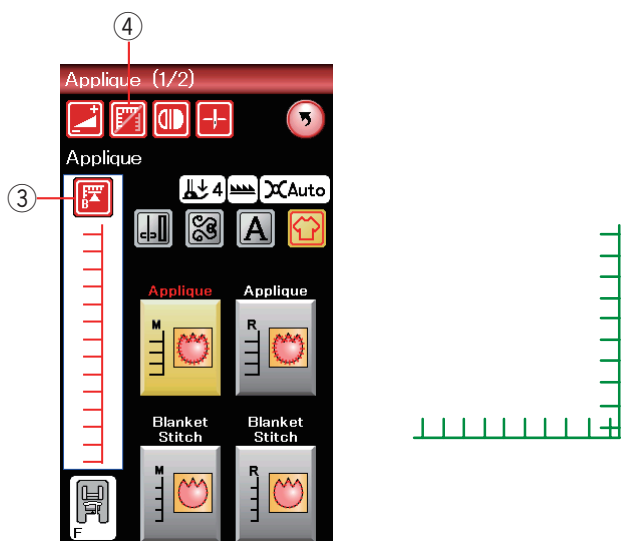
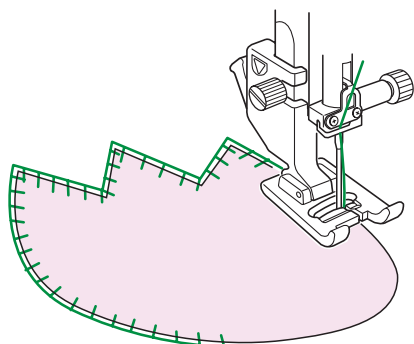
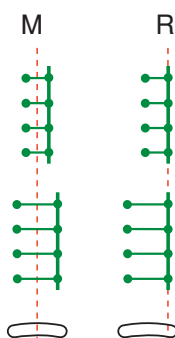
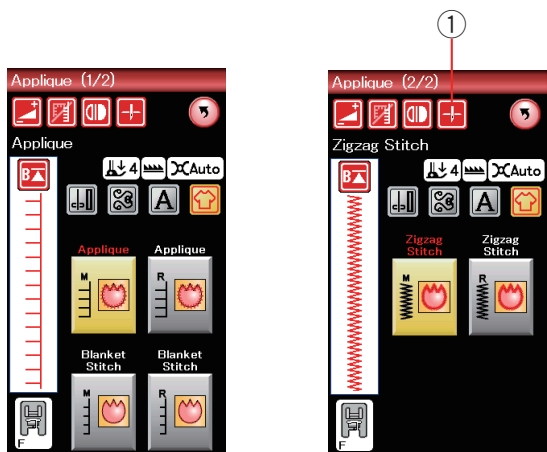

Starting over from the corner

Press the startover key before sewing in the new direction to sew from the beginning of the pattern.

- ③ Startover key

Two options of startover are available for applique stitches. Press the cornering key to select normal startover or cornering startover.

The key icon will change to show which option is being selected when pressing the key.

- ④ Cornering key

Normal startover:

Sew a locking stitch then start sewing from the beginning of the pattern.

Cornering startover:

Start sewing from the beginning of the pattern without a locking stitch.

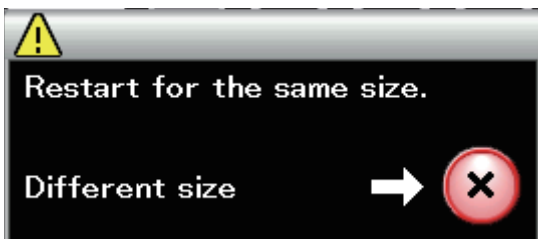
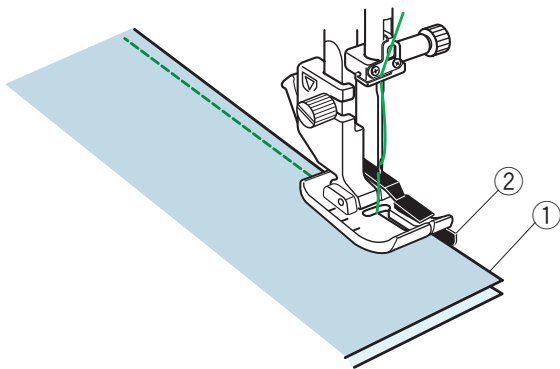
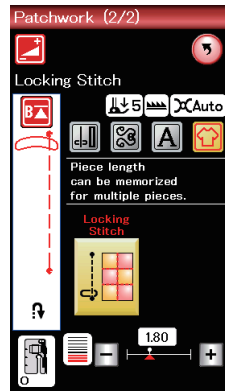
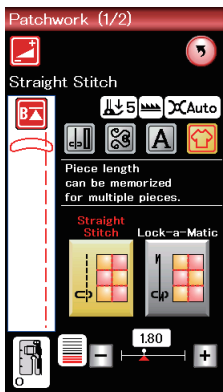

Patchwork

Patchwork piecing

There are 3 stitches for seaming patchwork pieces in this section.

The default stitch length is set at 1.8 mm, ideal for patchwork piecing, but you can fine tune the stitch length by pressing the “+” or “-” key.

Attach 1/4” seam foot O, which helps you to keep a constant 1/4” (6 mm) seam allowance.

Put 2 pieces of fabric with right sides together.

Place the patchwork pieces under the foot so that the edge of the fabric matches the guide on the presser foot.

- ① Edges of fabric
- ② Guide on 1/4” seam foot O

When you stop the machine, a message will appear. Press OK key and the machine memorizes the seam length to sew another piece of the same length. Press the X key to sew in a different size.

After sewing the memorized length, a message will appear.

To sew the same length, start the machine and it will stop automatically after sewing the memorized length.

Press the X key to sew in a different size.

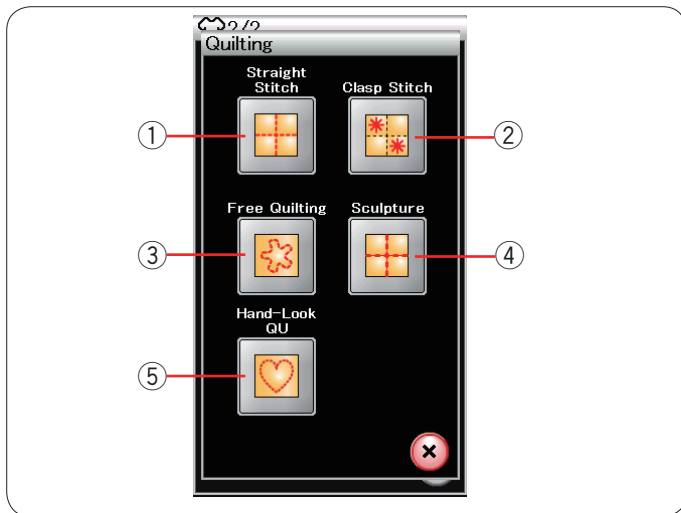

Quilting

In this section, 5 types of useful stitches for quilting are available.

- ① Straight stitches
- ② Clasp stitches
- ③ Free motion quilting stitches
- ④ Sculpture stitches
- ⑤ Hand-look quilt stitches

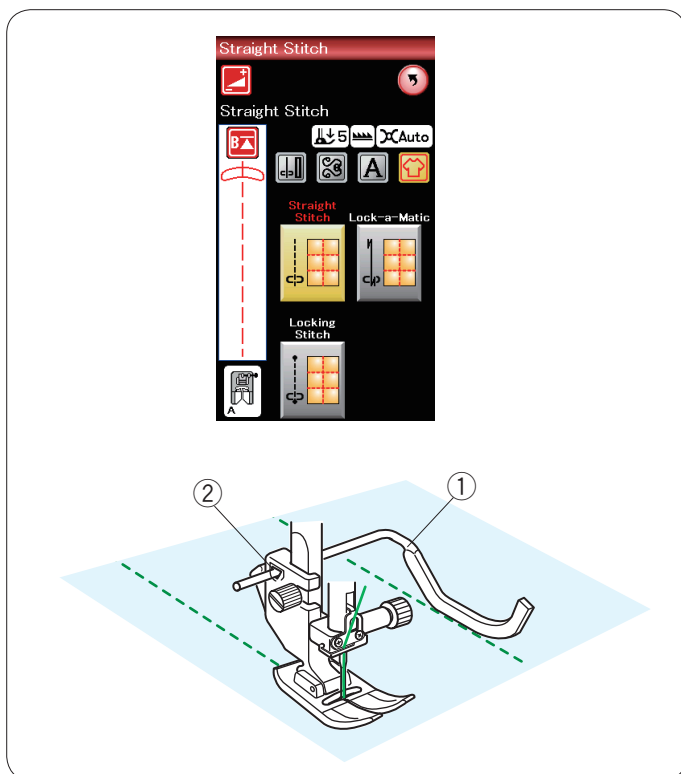

Straight stitches

The quilting guide bar is helpful when sewing parallel, evenly spaced rows of stitching.

Insert the quilting guide bar into the hole in the rear of the foot holder.

Shift the quilting guide bar to the desired spacing.

- ① Quilting guide bar
- ② Hole

Sew rows of stitching while tracing the previous row of stitches with the quilting guide bar.

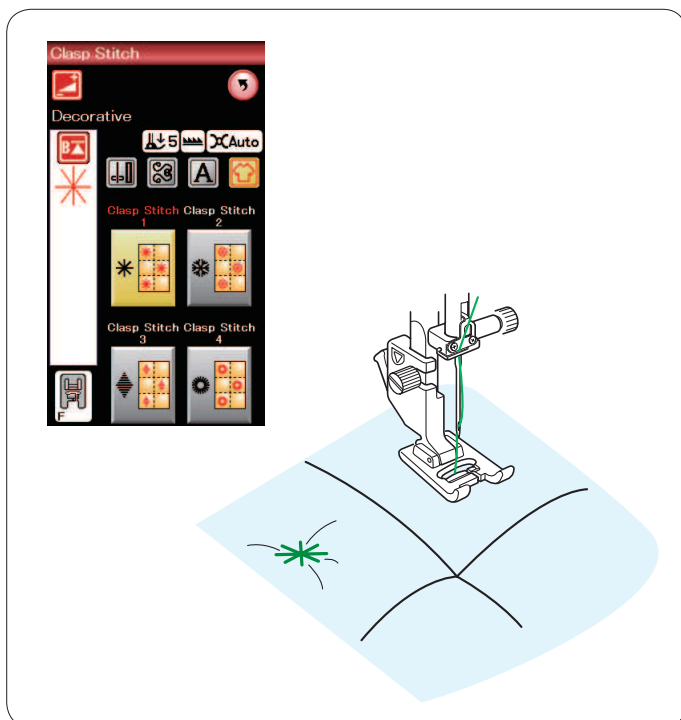

Clasp stitches

You can close quilt layers and batting using the clasp stitch.

Use satin stitch foot F.

The machine sews one unit of the pattern and automatically stops with the needle in up position when completed.

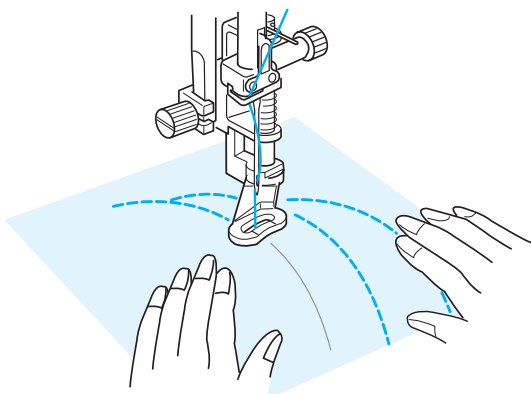
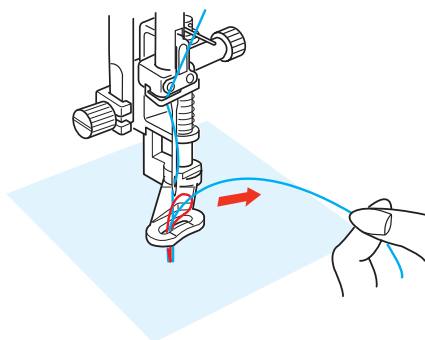
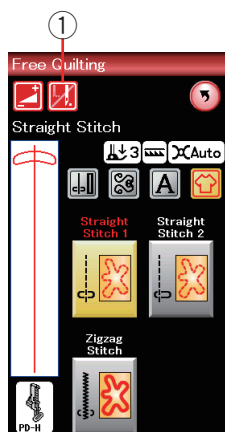

Free quilting

For free quilting, use the darning foot PD-H (refer to page 18 for how to attach the darning foot). Lower the feed dog before start sewing.

One stitch off

The machine stops automatically after sewing one stitch so that you can bring the bobbin thread up to prevent it from bunching up on the wrong side of the fabric.

Hold the needle thread and sew one stitch and the machine stops automatically.

Pull the needle thread up to bring the bobbin thread up.

Hold both the needle and bobbin threads and sew several stitches to secure the threads.

You can trim the thread tails with scissors.

The machine will stitch continuously when you resume sewing.

If you wish to start sewing without “one stitch off”, press the one stitch off key to cancel this function.

The key icon changes to .

When “one stitch off” is active, the key icon shows .

① One stitch off key

To Sew

Sew at medium speed while guiding the fabric with your hands.

Move the quilt 3 mm or less per stitch.

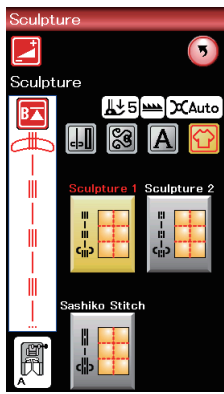

Sculpture stitches

These stitches are used to accentuate design outlines and to create a mock hand-quilt.

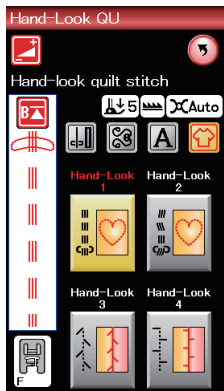

Hand-look quilt stitches

Use a transparent nylon thread for the needle and ordinary sewing thread for the bobbin. The bobbin thread is pulled up on the right side of the fabric and the stitches will look as if sewn by hand.



CUSTOMIZING MACHINE SETTINGS

Press the set mode key to enter the machine setting mode.

You can select various options and customize the machine settings to suit your personal preference.

- ① Set mode key

Press one of the 4 keys to select the mode to customize.

② Common Setting Mode

In this mode, you can customize the machine settings and options for both ordinary sewing and embroidery.

③ Ordinary Sewing Setting Mode

In this mode, you can customize the machine settings and options for ordinary sewing.

④ Embroidery Setting Mode

In this mode, you can customize the machine settings and options for embroidery. (refer to pages 114-116 for operation).

⑤ Language Selection Mode

In this mode, you can select the desired language for the screen messages.

To browse pages in each mode, press the next page key or previous page key

- ⑥ Previous page key
- ⑦ Next page key

Registering the Custom Settings

After customizing the settings, press the OK key to enable the new settings.

To cancel the changes to the settings, press the X key and the setting mode window will close.

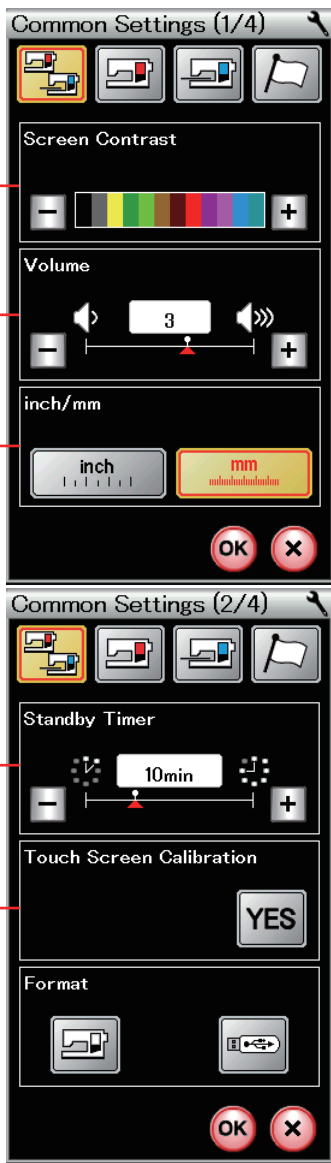

Common Setting Mode

① Screen Contrast

You can adjust the contrast of the visual touch screen by pressing the “+” or “-” key.

② Sound Volume

The buzzer sound can be adjusted by pressing the “+” or “-” key.

Set the value to “0” to mute the buzzer.

③ Inch/mm Option

You can set your machine’s measurement unit to either inches or millimeters by pressing the “inch” or “mm” icon key.

The default unit is millimeters.

Press the next page key to show the next menu.

④ Standby Timer

The sewing lights will turn off, the visual touch screen will go dark and the machine will be in standby mode if you have not used the machine within the time period set by this timer. Doing any operation will turn the lights and screen on again.

The standby timer can be set from 1 to 30 minutes.

If you wish to turn off the timer, press and hold the “+” key until “OFF” shows in the timer window.

⑤ Touch Screen Calibration

You can calibrate the key positions of the touch screen if you feel the touch screen key is not responding properly.

Press the YES key to open the calibration window.

Press the “+” sign with the touch panel stylus as the sign appears (① - ⑤).

When you press the last sign, the screen shows “END” ⑥ and the calibration window will close.

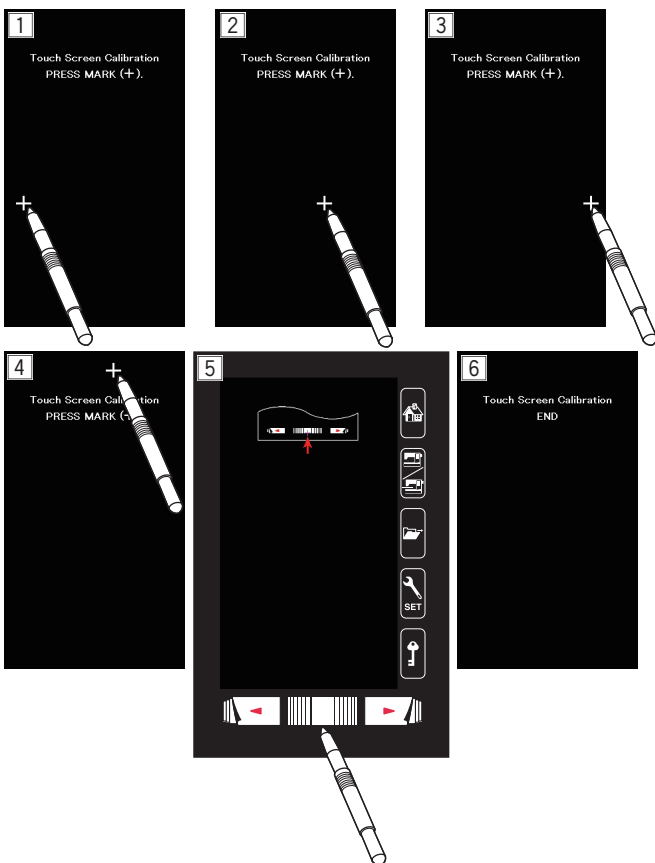

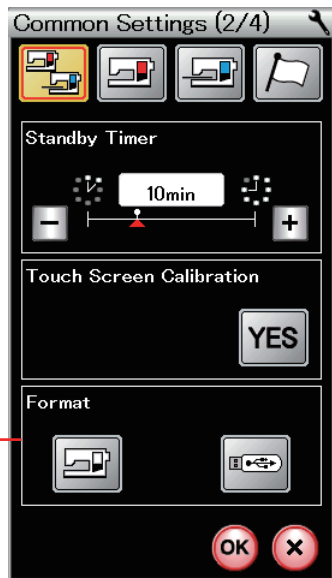

⑥ Formatting the memory

If the internal memory of the machine or USB flash drive stick does not function due to damage to the memory bank, you need to re-enable it by formatting the memory.

To format the machine's internal memory, press the machine icon key and a confirmation message will appear. Press the OK key to format.

To format a USB flash drive, press the USB icon key and the confirmation window will open.

Press the next page key to show the next menu.



CAUTION:

Do not turn off the power or disconnect the USB flash drive while a warning message is displayed otherwise it may damage the memory bank.

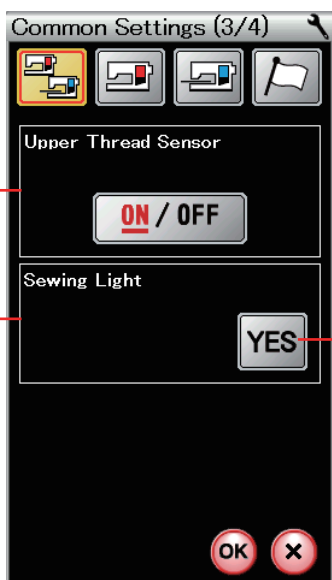

⑦ Upper Thread Sensor

If you need to run the machine without threads, turn off the upper thread sensor.

After altering the settings press the OK key to enable the new settings.

⑧ Sewing Light

Press the YES key to open the sewing light option window.

Press each of the sewing light icons on the screen for turning on or off the sewing lights individually.

(A) YES key

Press the next page key to show the next menu.

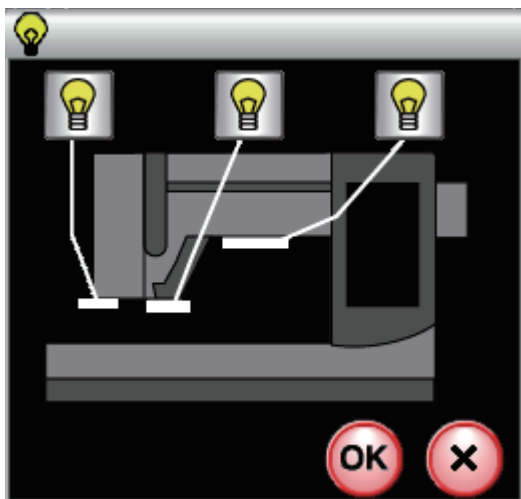

⑨ Background Color

You can select black, green or pink for the background color of the visual touch screen by pressing the relevant icon key.

⑨

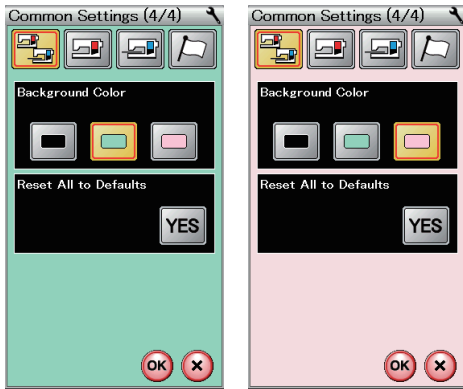
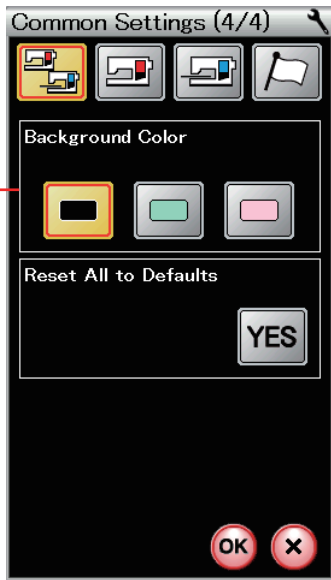

⑩

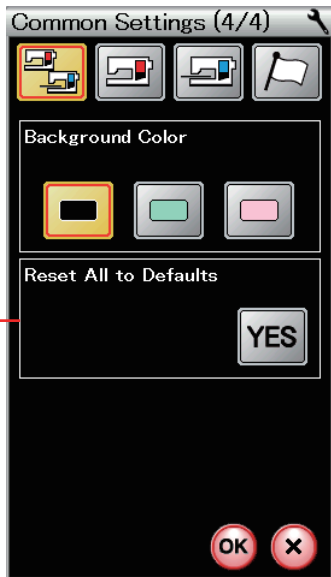

⑩ Reset All to Defaults

Press the YES key to reset all the parameters to the original values (factory settings).

Press the OK key to exit the setting mode.

Ordinary Sewing Setting Mode

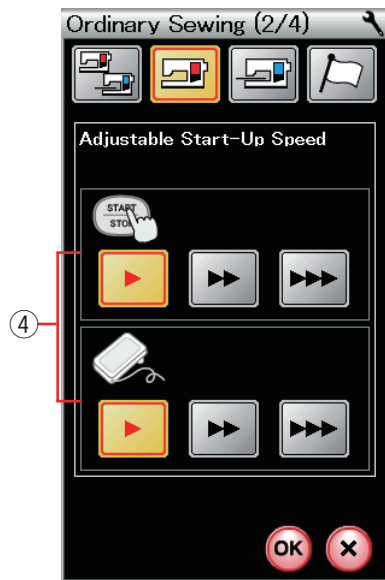
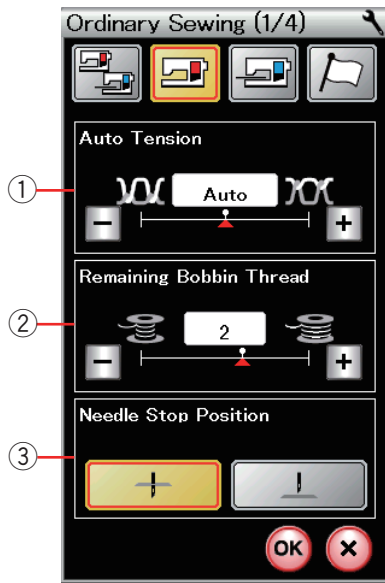

① Auto thread tension

The machine automatically adjust the thread tension for the selected pattern.

You can adjust the automatic thread tension level by pressing the “+” or “-” key.

② Low bobbin thread warning

The machine has a function to display warning message before the bobbin thread is running out.

You can adjust the low bobbin thread warning level by pressing the “+” or “-” key.

Set the level to a larger number when using thick threads and vice versa.

To turn off the low bobbin thread warning, press the “-” key until “OFF” shows in the window.

③ Needle Stop Position

The machine always stops with the needle in the down position except when sewing buttonholes, specialty stitches, monograms, etc. However you can change the needle stop position to up by pressing the needle up key. Press the next page key to show the next menu.

④ Adjustable Start-Up Speed

The machine will start running slowly and the sewing speed will gradually increase to maximum. You can select the desired start-up speed from slow, normal or high by pressing the corresponding key, and set the speed for the start/stop button or foot control individually.

Press the next page key to show the next menu.

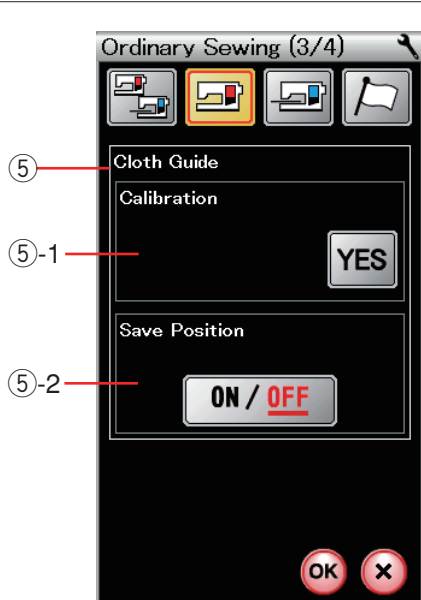

⑤ Cloth Guide

⑤-1 Calibration of the default position

Attach the embroidery unit.

The default position of the cloth guide is 15 mm (5/8") from the center needle drop position. However, you can fine tune the default position of the cloth guide.



Press the YES key and a warning message will appear. Press the OK key and the carriage will move to the standard position.

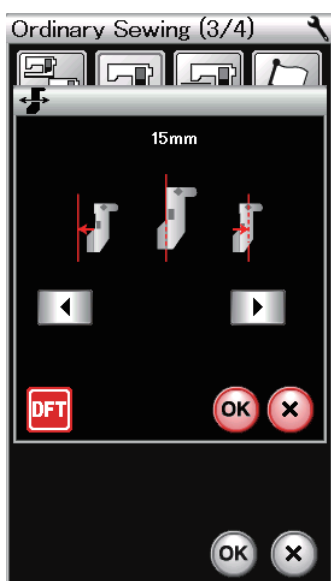

Press the ◀ key or ▶ key to adjust the position of the cloth guide.

Press the **DFT** key to back to the default cloth guide position.

Press the OK key and the carriage will return to the home position.

⑤-2 Saving favorite position

If you have set the cloth guide to your favorite position, 6.4 mm (1/4") in the manual setting window for example (refer to page 35), you can save this position for future use.

To save favorite position, press the ON/OFF key to turn ON the save position option.

Press the next page key to show the next menu.

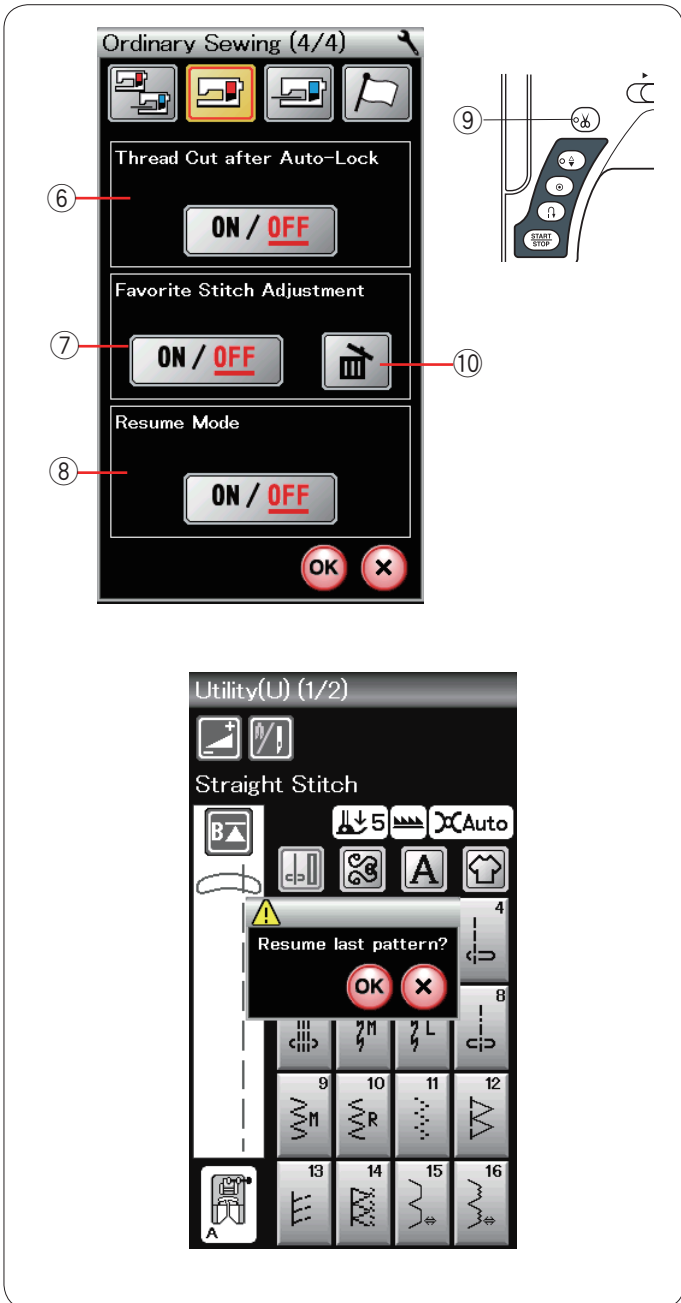

⑥ Thread Cut after Auto-Lock

The machine automatically trims the threads after sewing locking stitches when this option is turned on. The LED signal ⑨ is turned on when “Thread Cut after Auto-Lock” is on.

⑦ Favorite Stitch Adjustment

If you wish to save the changes to manual stitch settings, turn on this option by pressing the ON/OFF key. Press the delete icon ⑩ to clear the manual stitch setting.

NOTE:

This option is available for all stitches except monogramming in ordinary sewing mode.

⑧ Resume Mode

Turn on this option when you wish to resume the last pattern sewn before turning the power switch off.

When the power is turned on again, the confirmation message will appear. Press the OK key to resume the last pattern.

After customizing the settings, press the OK key to enable the new settings.



Language Selection Mode

Select the desired language and press the OK key. The visual touch screen shows messages in the selected language.

NOTE:

The language selection cannot be switched while programming a monogram in embroidery mode.

Correcting Deformed Stitch Patterns

The sewing results of the stretch stitch patterns may vary depending upon the sewing conditions, such as sewing speed, type of the fabric, number of layers etc.

Always test sew on a scrap piece of the fabric that you wish to use.

If decorative stitch patterns, letters, numbers or the manual buttonhole stitch are deformed, correct them with the feed balancing dial.

Remove the cap by using the screwdriver etc. Make sure not to scratch the machine body with the screwdriver.

① Cap

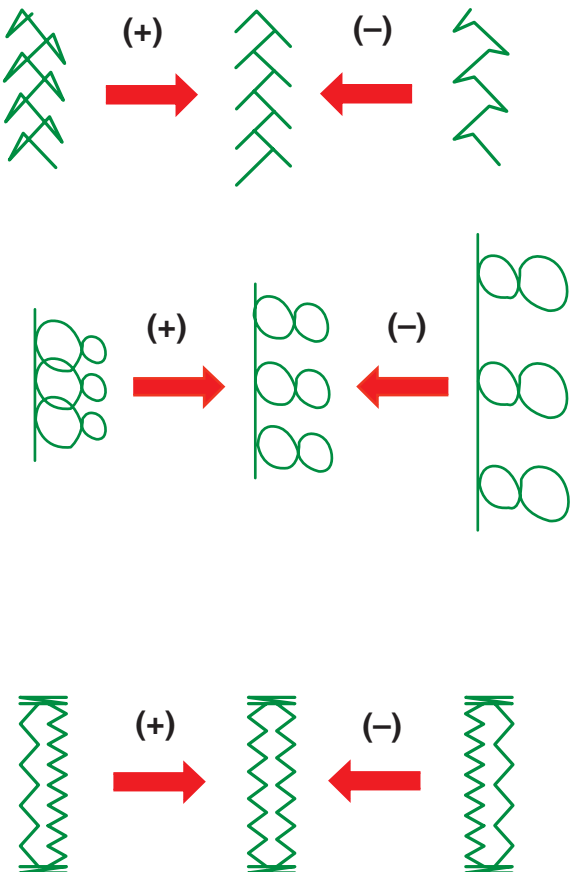
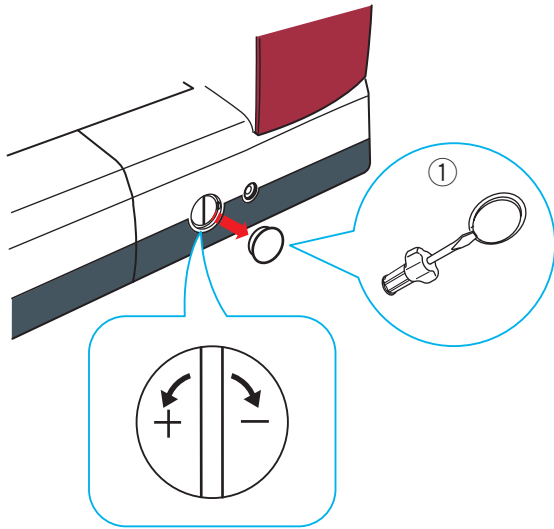

Decorative stretch stitch patterns

If the pattern is compressed, turn the dial in the direction of “+”.

If the pattern is drawn out, turn the dial in the direction of “-”.

Letters and numbers

If the pattern is compressed, turn the dial in the direction of “+”.

If the pattern is drawn out, turn the dial in the direction of “-”.

Stitch balance of the stretch buttonhole (B6)

The stitch balance of the right and left rows of the stretch buttonhole may vary depending on sewing conditions.

If the stitches are not balanced, correct the unevenness with the feed balancing dial.

If the right row is denser, turn the dial in the direction of “+”.

If the left row is denser, turn the dial in the direction of “-”.

NOTE:

Return the feed balancing dial to the neutral position and attach the cap when the sewing is finished.

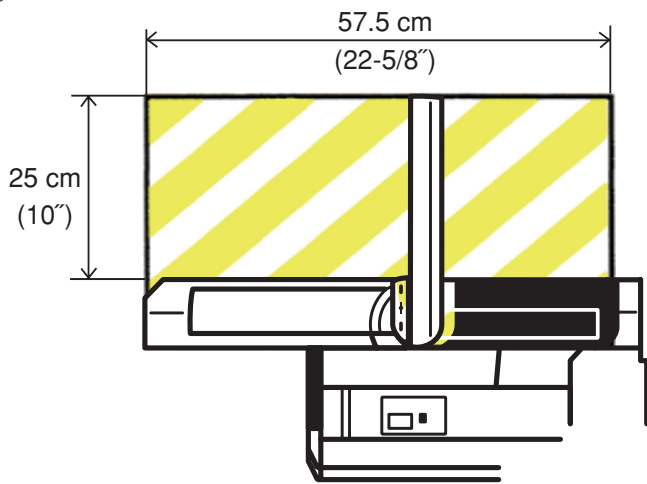

EMBROIDERY MODE

Embroidery Unit

NOTE:

Be sure to provide sufficient space around the machine to allow the hoop to move freely.
Do not place anything inside the area shown on the left.

Attaching the embroidery unit

Turn the power switch off.

Remove the cover from the machine.

- ① Power switch
- ② Cover

NOTE:

Always attach the extension table except when using the free-arm hoop (optional item).

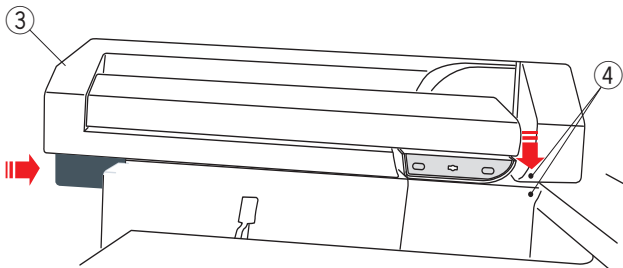
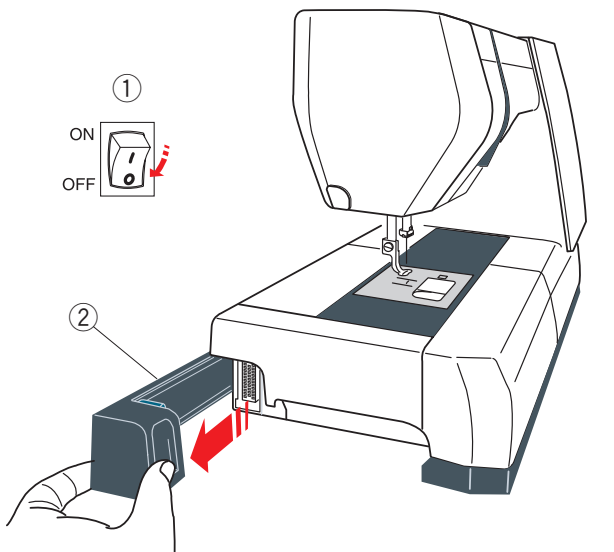
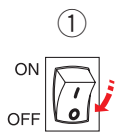

Place the embroidery unit on the back side of the machine base, matching the small dots as shown.

- ③ Embroidery unit
- ④ Small dots

Slide the embroidery unit along the machine to the right and push the embroidery unit firmly until it fits securely.

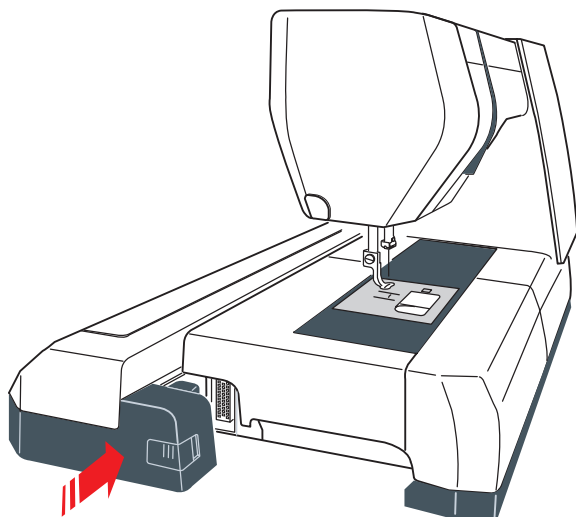

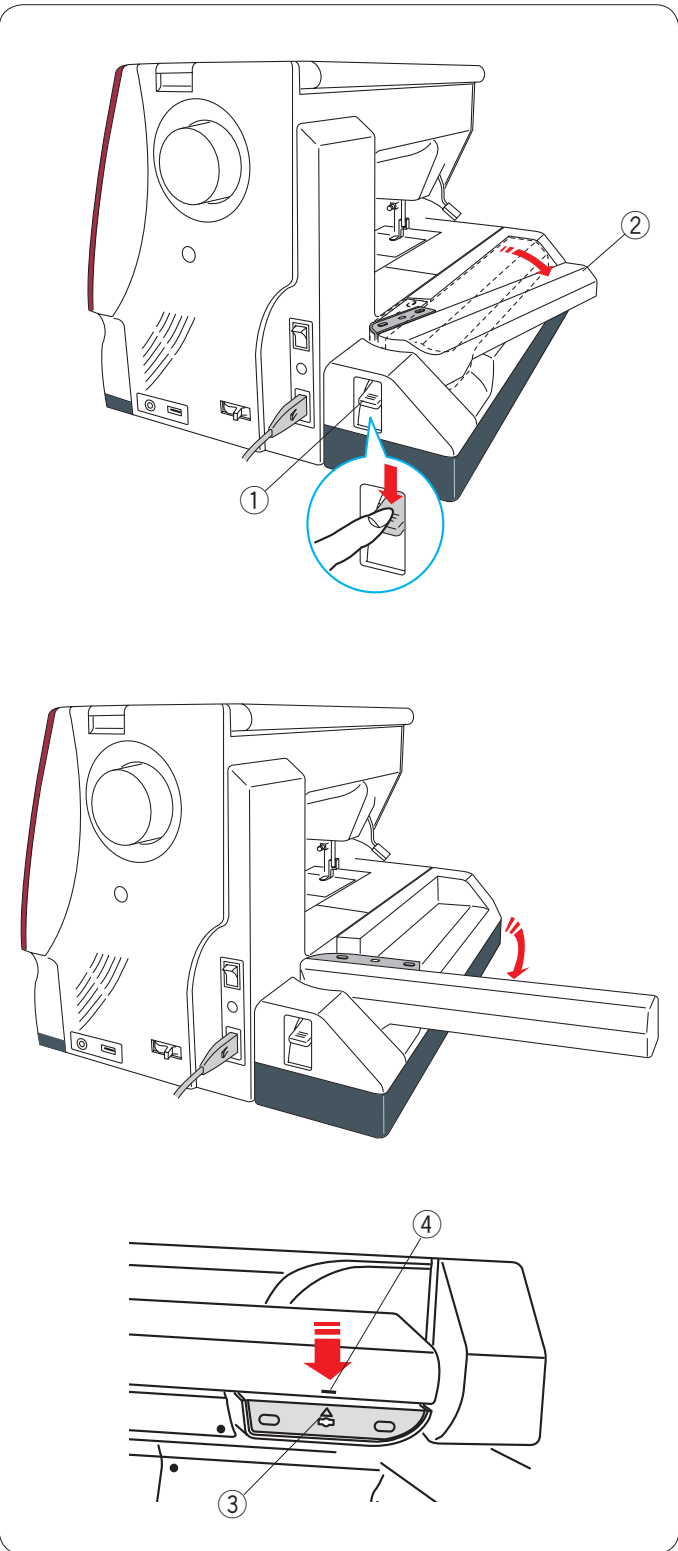

Extending the carriage arm

Press down the carriage arm release lever to extend the carriage arm.

- ① Carriage arm release lever
- ② Carriage arm

Swing out the carriage arm until it locks in the fully extended position.

CAUTION:

Do not push on the carriage arm when it is extended. Do not force to move the carriage or carriage arm by hand.

Do not hold the carriage or carriage arm while it is moving.

Doing any of the above may cause damage to the carriage mechanism.

CAUTION:

Never move the carriage by hand regardless of whether the power is on or off, otherwise the machine may be damaged when opening the carriage arm.

Be sure that the carriage is at the home position when opening the carriage arm (a triangle mark on the carriage matches with a bar sign on the carriage arm).

- ③ Triangle mark
- ④ Bar sign

Detaching the embroidery unit

NOTE:

Be sure to remove the embroidery unit when carrying or storing the machine.

Remove the hoop from the carriage and press the mode switch key to return the carriage to the home position.

NOTES:

If the needle is in down position, make sure to raise the needle by pressing the needle up/down button. The feed dog will be raised automatically.

Push down the carriage arm release lever to retract the carriage arm.

- ① Carriage arm release lever
- ② Carriage arm



WARNING:

Be careful not to get your finger caught between the embroidery unit and machine bed when the extension table is not in place and the carriage is being returned to home position.

Retract the carriage arm to the stored position.



CAUTION:

Never move the carriage by hand regardless of whether the power is on or off, otherwise the machine may be damaged when retracting the carriage arm. Be sure that the carriage is at the home position when retracting the carriage arm (a triangle mark on the carriage matches with a bar sign on the carriage arm).

Turn the power switch off.

Push the embroidery unit release button.

Slide the embroidery unit to the left and remove it.

- ③ Power switch
- ④ Embroidery unit release button

Attach the cover to the machine.

- ⑤ Cover

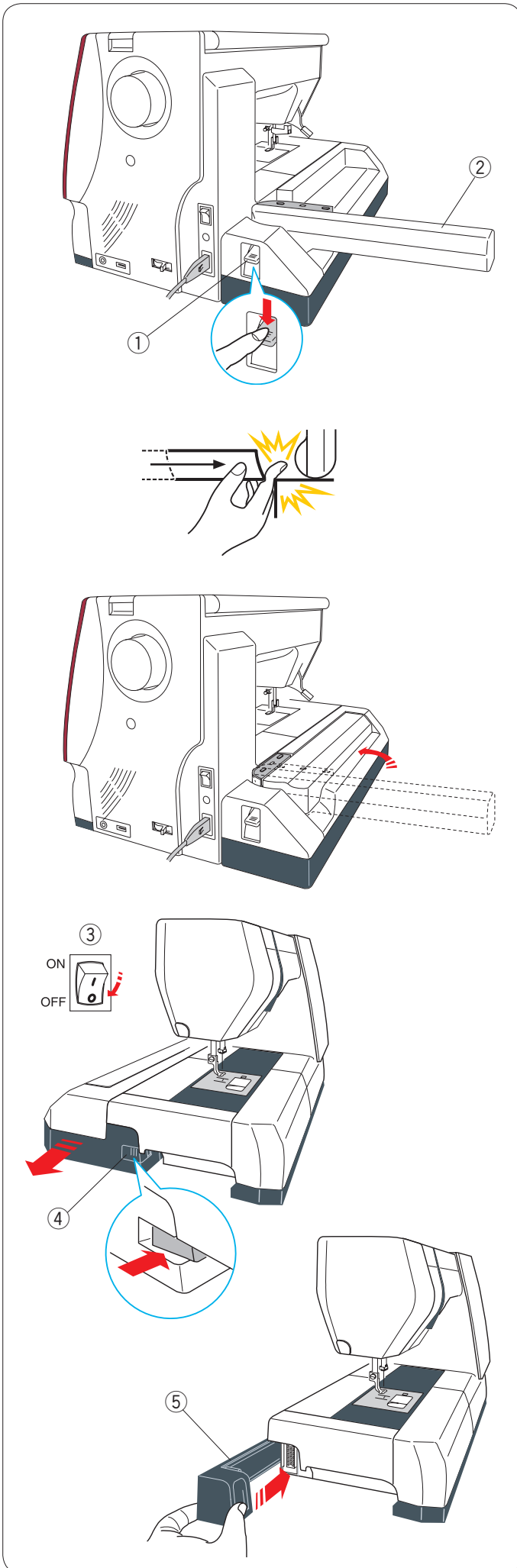

Attaching the Embroidery Foot

Use the embroidery foot P for embroidery.

Raise the needle and presser foot.

Turn the power switch off or press the lockout key.

- ① Lockout key



Loosen the setscrew with the screwdriver and remove the foot holder.

- ② Setscrew
- ③ Foot holder

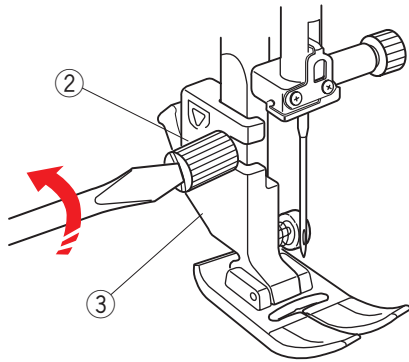

Attach the embroidery foot P to the presser bar from behind. Tighten the setscrew securely.

- ④ Embroidery foot P

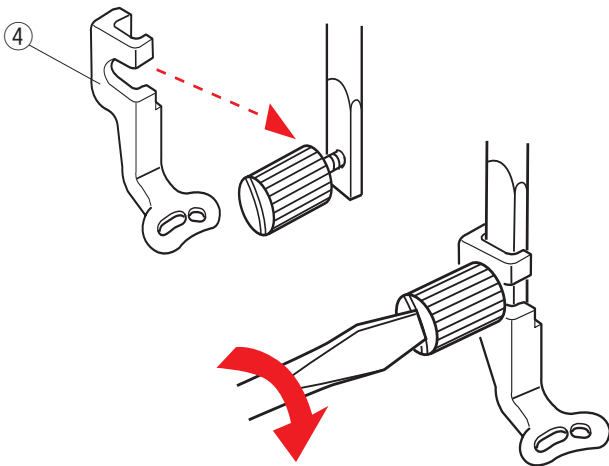

Foot pressure

Set the foot pressure dial at "3" for embroidery.

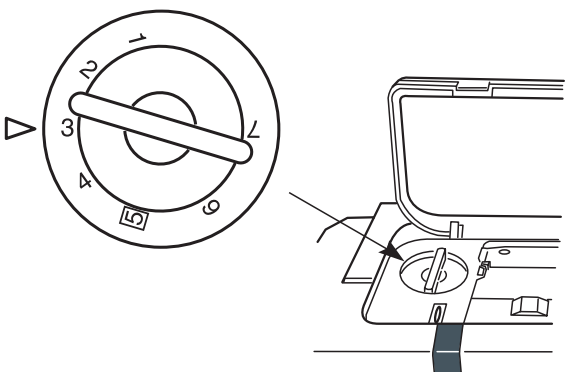

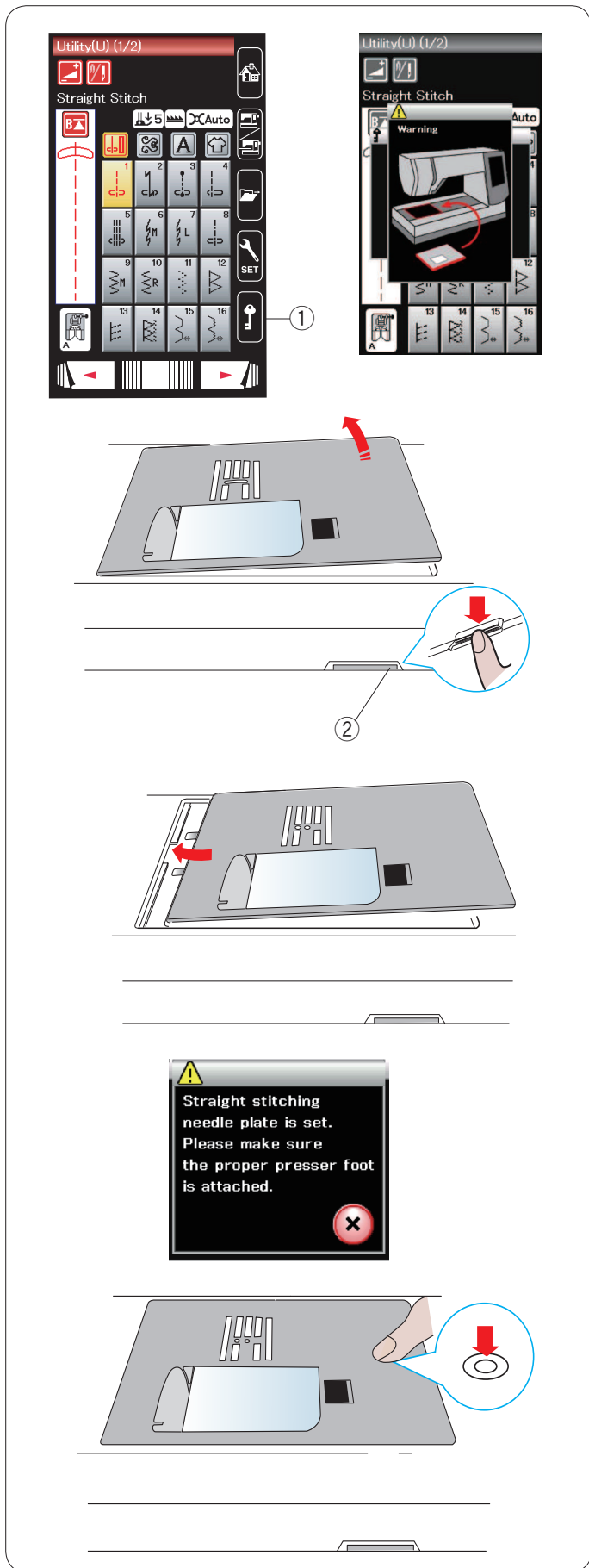

Attaching the Straight Stitch Needle Plate

Use the straight stitch needle plate for embroidery.

Raise the needle and presser foot. Press the lockout key.

- ① Lockout key

Remove the extension table.

Push down the needle plate release lever and the needle plate will snap off.

A message will appear warning that the needle plate is not secured.

Remove the needle plate.

- ② Needle plate release lever

Place the straight stitch needle plate in the opening for the needle plate.

Match the left edge of the needle plate with the opening.

Push the mark on the needle plate down until it locks in place.

The warning message disappears and a confirmation message will appear.

Press the X key and the machine automatically selects the straight stitch.

NOTE:

Raise the presser foot to the extra lifted position for easy removal and attachment of the needle plate.

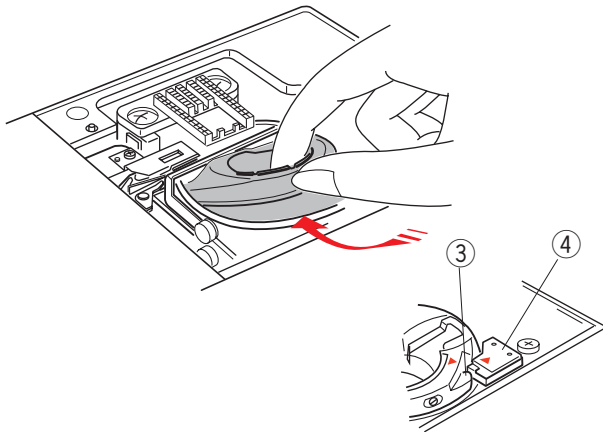
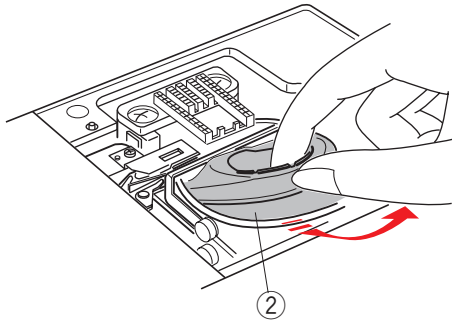
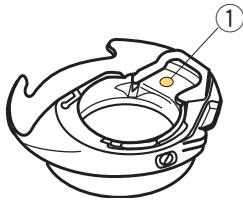

Special Bobbin Holder for Embroidery

Replace the standard bobbin holder with the special bobbin holder for embroidery when using bobbin threads other than Janome bobbin thread for embroidery.

NOTE:

The special bobbin holder is marked with a yellow dot for identification.

- ① Yellow dot

Remove the needle plate (refer to the previous page).
Take out the standard bobbin holder.

- ② Standard bobbin holder

Insert the special bobbin holder into the hook race.
Make sure to match the knob of the bobbin holder with the stopper on the machine.

Attach the needle plate.

- ③ Knob
- ④ Stopper

NOTE:

Use the standard bobbin holder when sewing lace designs and quilting designs that use the same thread for the bobbin as the needle thread.

Embroidery Hoops

There are 2 embroidery hoops included in the standard accessories.

① **Embroidery hoop SQ14a**

An square embroidery hoop with a 14 cm (5.5") square embroidery area

② **Embroidery hoop RE20a**

A square embroidery hoop with a 20 cm (7.9") by 17 cm (6.7") embroidery area

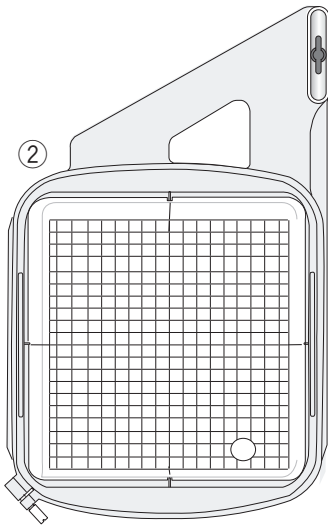
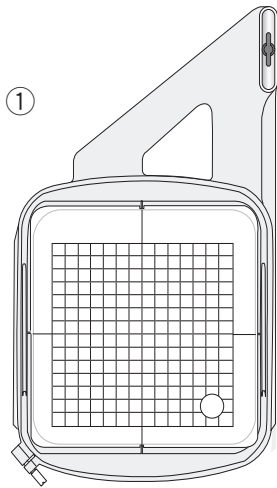

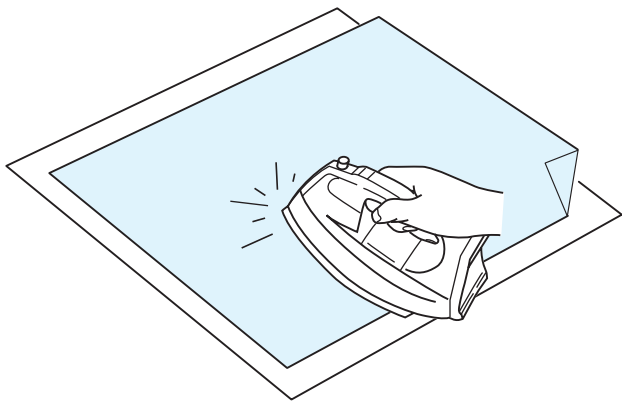

Stabilizers

To create the best quality embroidery, it is important to use stabilizers.

How to use:

Attach the stabilizer to the wrong side of the fabric.

You may need to use more than one layer.

For firm fabrics, you may place thin paper under the fabric.

The non-adhesive type should be used when embroidering fabric which cannot be ironed or for sections which are difficult to iron.

Cut the stabilizer larger than the embroidery hoop and set it on the hoop so that the entire piece is fastened with the hoop to prevent any looseness in the fabric.

Attaching the stabilizer

Place the wrong side of fabric and the glossy side of the stabilizer together. Fold up a corner of the stabilizer and fuse it with an iron.

NOTES:

Fold up a corner of the stabilizer, to make it easier to peel off the excess stabilizer after stitching.

Ironing temperatures vary depending on the kind of adhesive stabilizer you are using.

Types of the stabilizers

Type	Usage	Property
Tear-away	Stable woven fabrics	Made from a fiber that will tear easily.
Iron-on	Knits and all kinds of unstable fabrics	Adhesive type fusible with an iron.
Cut-away	Knits and all kinds of unstable fabrics	Non-woven fabric that does not tear.
Water soluble	Cutwork or lace embroidery Right side of looped fabrics such as towels to avoid loops coming through the embroidery	A thin film that will dissolve in water.

NOTE:

Sticky type stabilizers can be used only for securing a small piece of fabric or work that cannot be secured in the hoop. Or securing velvet and other napped fabric that would be permanently marked by the hoop. Clean the bobbin holder after stitching as glue can get stuck on it.

Setting the Fabric in an Embroidery Hoop

Prepare a piece of fabric and attach a stabilizer to the wrong side of the fabric.

The fabric and stabilizer should be larger than the hoop size.

Draw the centerlines on the fabric with tailor's chalk.

- ① Fabric
- ② Centerlines

Lay the inner hoop and template on the fabric, matching the centerlines of the fabric with the template.

- ③ Inner hoop
- ④ Template

Loosen the hoop tightening screw on the outer hoop.

Place the inner hoop and fabric on the outer hoop.

- ⑤ Hoop tightening screw
- ⑥ Outer hoop

Push the inner hoop and fabric into the outer hoop.

Tighten the screw on the outer hoop to stretch the fabric.

Make sure that the fabric is stretched drum-tight in the hoop.

Clamp the fabric to the hoop with the magnetic clamps.

- ⑦ Magnetic clamp

NOTE:

Make sure to match the alignment marks of the outer and inner hoops when stretching the fabric.

- ⑧ Alignment marks

Remove the template.

NOTE:

When embroidering thick fabrics such as quilt layers, check if the fabrics do not obstruct the hoop when it is moved to the extreme right position.

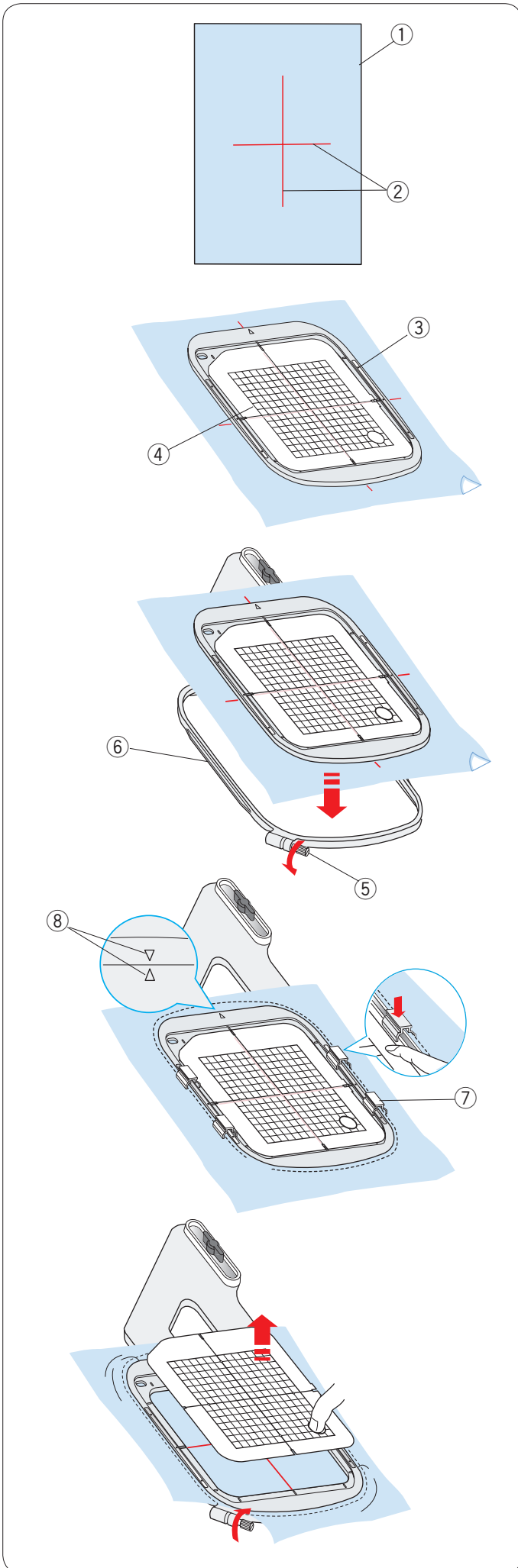

Attaching the Embroidery Hoop to the Machine

Turn the power switch on and open the carriage arm. Press the mode switch key and a warning message will appear.

Press the OK key and the carriage will move to the starting position. The feed dog is lowered automatically. The visual touch screen will display the embroidery mode window.

- ① Mode switch key

NOTE:

The drop feed lever will shift as the feed dog is lowered.

NOTE:

If you press the mode switch key with the carriage arm retracted, a confirmation message will appear.

Do not press the OK key or X key. Instead, open the carriage arm.

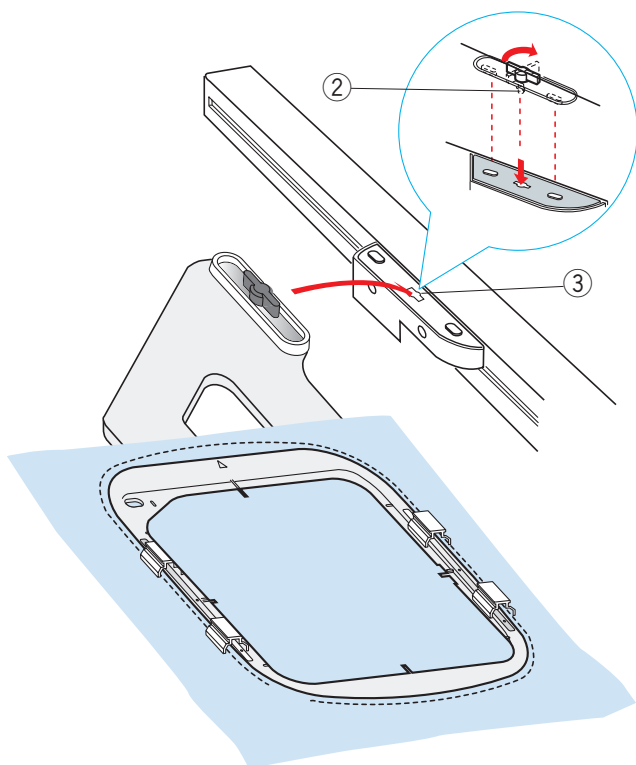
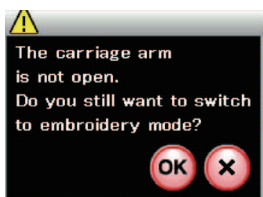
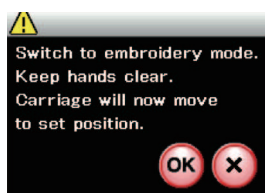

Place the hoop on the machine and attach the hoop to the carriage by inserting the lock pin of the hoop into the hole in the carriage.

Turn the knob clockwise to secure the hoop.

- ② Lock pin
- ③ Hole

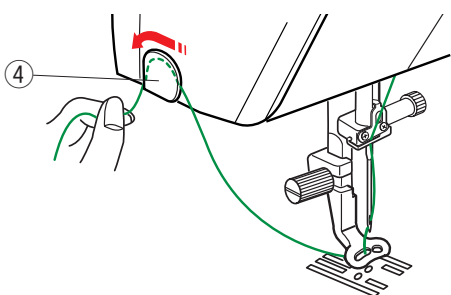

Thread holder

To avoid sewing over a tail of the needle thread, place the thread end on the thread holder.

- ④ Thread holder

Pass the needle thread through the hole in the embroidery foot and draw it up to the thread holder. Hang the thread on the thread holder from front to back.

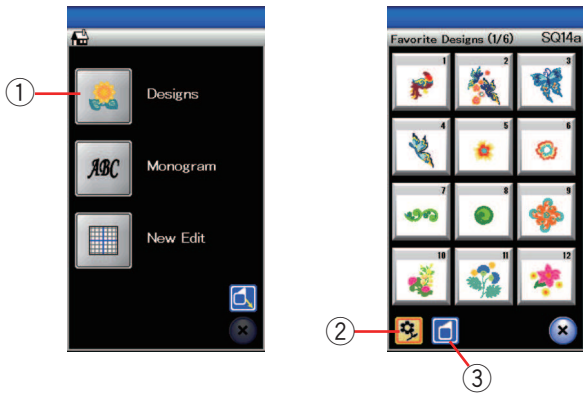

Selecting Built-in Embroidery Designs

Press the built-in design key and the first page of the design list of favorite designs will open.

- ① Built-in design key

Press the design category key to browse the design list by design category, or press the hoop selection key to browse the designs by hoop size.

- ② Design category key
- ③ Hoop selection key

(1/3)

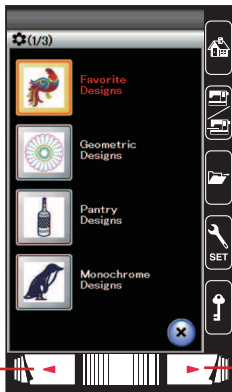

(2/3)

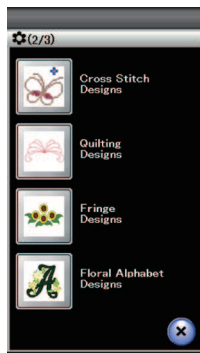

(3/3)

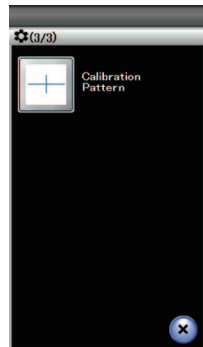

Design category

Press the design category key  to show the design lists by category.

Press the next or previous page key to browse the design lists.

- ④ Next page key
- ⑤ Previous page key

Page 1 of 3

- Favorite Designs
- Geometric Designs
- Pantry Designs
- Monochrome Designs

Page 2 of 3

- Cross Stitch Designs
- Quilting Designs
- Fringe Designs
- Floral Alphabet Designs

Page 3 of 3

- Calibration Pattern (for clothsetter)

Press the desired category to select and the pattern selection window will open.

Browse the pattern list with the next page key and select the desired pattern by pressing the pattern icon key.



Hoop size

Press the hoop selection key  and the hoop selection window will open. Select the same hoop as the one attached to the machine.

Browse the design list with the next page key and select the desired pattern by pressing the pattern icon key.

The visual touch screen will show the hoop confirmation window.

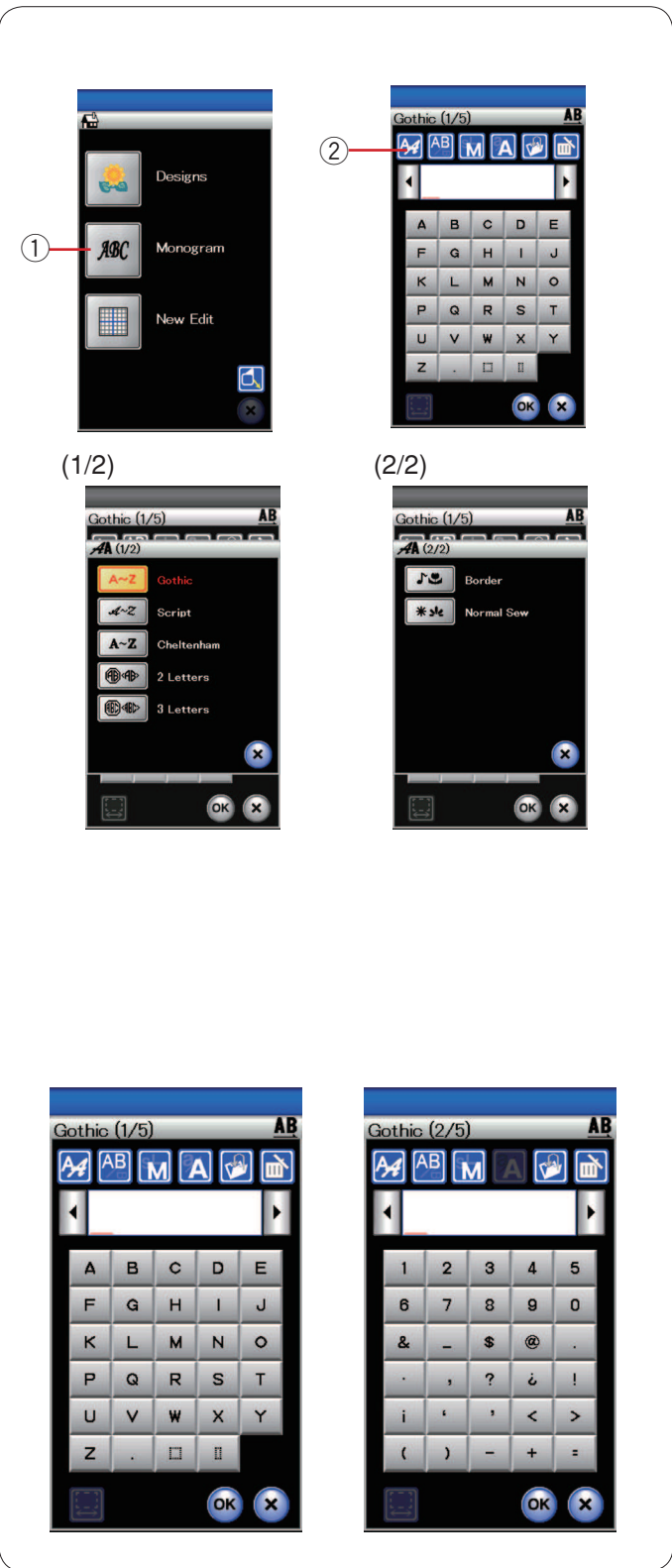

Monogramming

Press the monogram key and the monogram window for Gothic font will open.

Press the font selection key to open the font selection window.

- ① Monogram key
- ② Font selection key

You can select one of the 3 fonts for monogramming as well as 2 Letters, 3 Letters, border patterns and normal sew patterns.

The following fonts and patterns are available:

- Gothic font (5 pages)
- Script font (5 pages)
- Cheltenham font (5 pages)
- 2 Letters (one page)
- 3 Letters (one page)
- Border patterns (2 pages)
- Normal sew patterns (2 pages, patterns similar to ordinary stitches)

NOTE:

If you select Russian language for the visual touch screen, you can select Cyrillic alphabets in Gothic font as well.

Press the icon key of the desired font and the monogram window will open.

Browse pages with the page keys.

You can enter alphabet letters, numbers, symbols and European letters.



Function keys

① Font selection key

Press this key to open the font selection window.

② Lettering orientation key

Press this key to select the horizontal or vertical orientation.

③ Letter size key

You can select the following 3 letter sizes by pressing this key.

The approximate letter sizes of upper case are as follows:

L (Large): 30 mm (1.2")

M (Medium): 20 mm (0.8")

S (Small): 10 mm (0.4")

④ Letter case key

Pressing this key changes the letter case from upper case to lower case and vice versa.

⑤ Save file key

Pressing this key opens the save file window and allows you to save the text or monogram as a file.

⑥ Delete key

Press this key to delete the character above the cursor.

⑦ Cursor key

Press these keys to move the cursor to the left or right.

⑧ OK key

Press this key to confirm your entry and open the embroidery screen.

⑨ Space adjust key

This key is activated only when a space is entered.

If the spaces between characters look uneven, insert a blank space between characters and adjust the space width to justify.

Press this key to open the space adjustment window.

To increase the space width, press the "+" key.

To decrease the space width, press the "-" key.

NOTE:

The space width is shown only in millimeters.

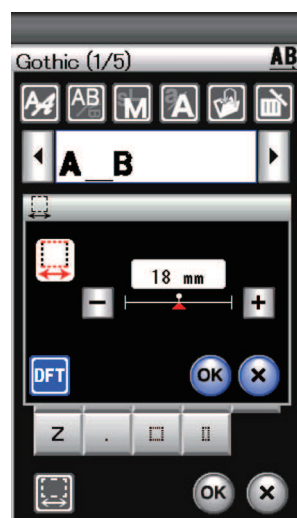
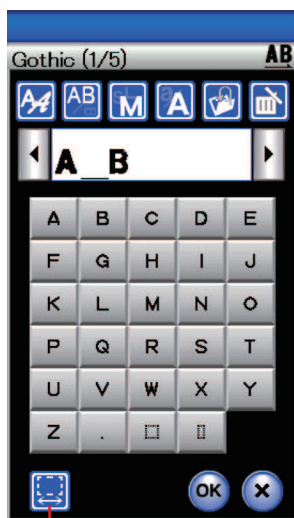

9

Programming a monogram

Example: Programming “R&B” in Gothic style font.

Enter “R”, the cursor shifts to the right and “R” is automatically memorized.

Press the letter size key and select small size.

① Letter size key

Enter “&”, the cursor shifts to the right and “&” is automatically memorized.

Press the letter size key and select medium size.

Enter “B”, the cursor shifts to the right and “B” is automatically memorized.

Press the OK key and a warning message will appear. Press the OK key and the carriage moves to starting position. The screen changes to the ready to sew window and a hoop confirmation message will appear. Press the OK key.

Color change

You can sew a multi-colored monogram by changing the thread color of each letter if you press the color change key before sewing.

The machine will stop automatically when each character has been sewn.

Change the thread to the next color and start sewing again.

② Color change key

Monogram placement

You can select one of 3 monogram placements: left justify, center justify and right justify.

① Left Justify

Press the  key to start sewing from the left end reference line on the template.

② Center Justify

Press the  key to sew in the center of the hoop.

③ Right Justify

Press the  key to sew from the right end reference line on the template.

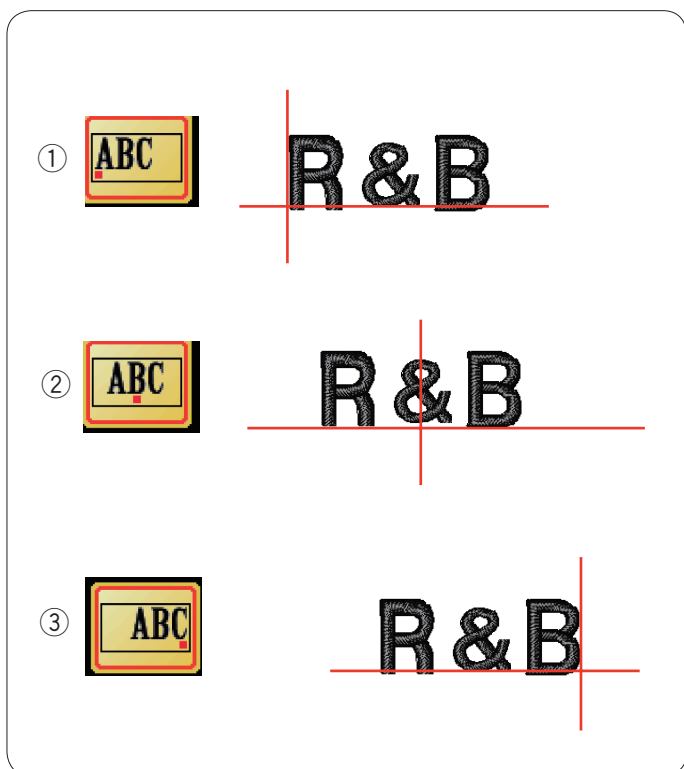
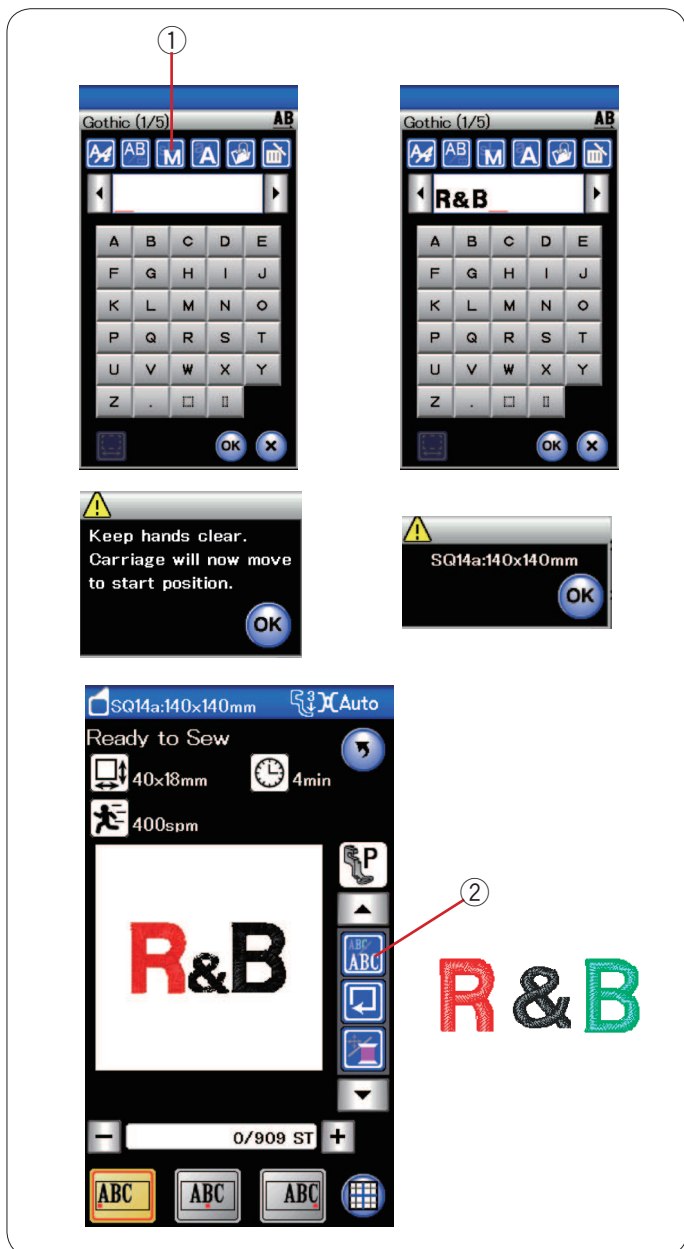



2- Letter monogram

Example: 2-Letter in an octagon

Press the font selection key.



Select 2-letter.



Select the octagon.



Enter "A" and "B".



Press the OK key and a warning message will appear. Press the OK key and the carriage moves to starting position. The screen changes to the ready to sew window and a hoop confirmation message will appear. Press the OK key.

NOTES:

The 3-letter monogram is sewn in the same way as the 2-letter monogram.

The starting position for the 2-letter and 3-letter monogram is in the center of the hoop.

Editing a monogram

Deleting a character: Deleting "R" from "MART"

Press the cursor key to move the cursor under "R".

- ① Cursor key

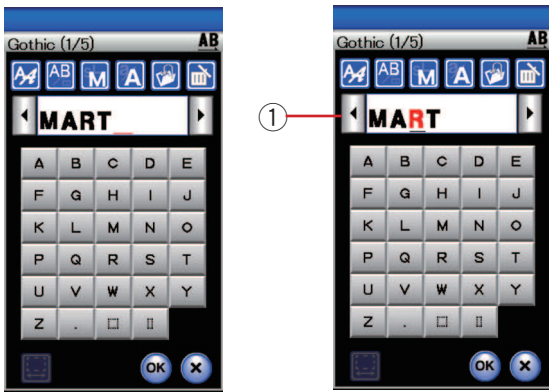

Press the delete key and letter "R" is deleted.

- ② Delete key

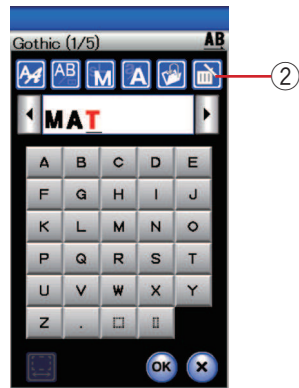

Inserting a character: Inserting "E" into "MAT"

Press the cursor key to move the cursor under "A".



Enter "E".

The letter "E" is inserted before "A".



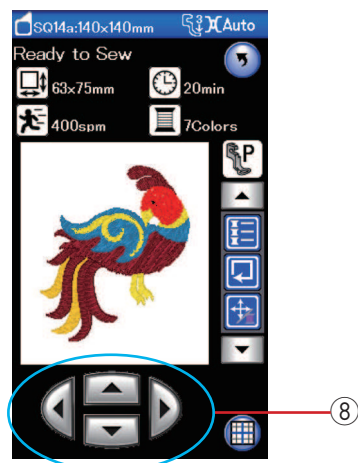
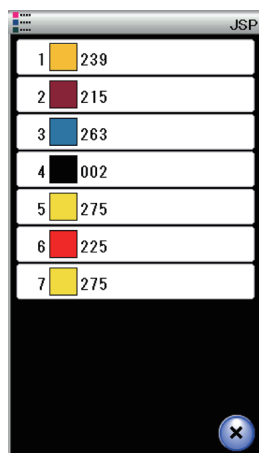
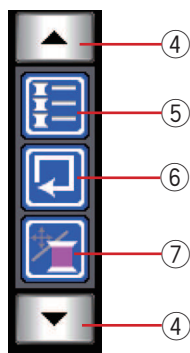

Ready to Sew Window

The ready to sew window shows embroidery function keys and information on the selected pattern.

Stitch back/forward keys

Press the “-” key to move the hoop back to a previous sewing point.

Press the “+” key to move the hoop ahead.

The hoop will move one stitch each time the key is pressed. Hold down the key to travel faster and jump 10 or 100 stitches at a time.

You can use these keys to move the embroidery hoop to where the thread has broken or run out.

- ① Stitch back key
- ② Stitch forward key

Editing mode key

Press this key to enter the editing mode (refer to page 107).

- ③ Editing mode key

Function keys

The function keys are displayed on the right side of the visual touch screen.

Press the arrow key to view the other function keys.

- ④ Arrow keys

• Color list key

Press this key to view a list of thread colors employed in the selected design.

- ⑤ Color list key

• Trace key

You can check the size of the embroidery area by tracing the pattern outline without stitching or with basting stitches (refer to page 101).

Press the trace key and the trace option window will open.

- ⑥ Trace key

Jog/stitch key

Press this key to switch the jog keys to the stitch back/forward keys or vice versa.

Adjust the hoop position with the jog keys so that the needle position comes right above the center of the reference lines on the fabric.

To use the jog keys after sewing has started, stop the machine and return the stitch counter to zero by pressing the stitch back key and/or page keys.

- ⑦ Jog/stitch key
- ⑧ Jog keys

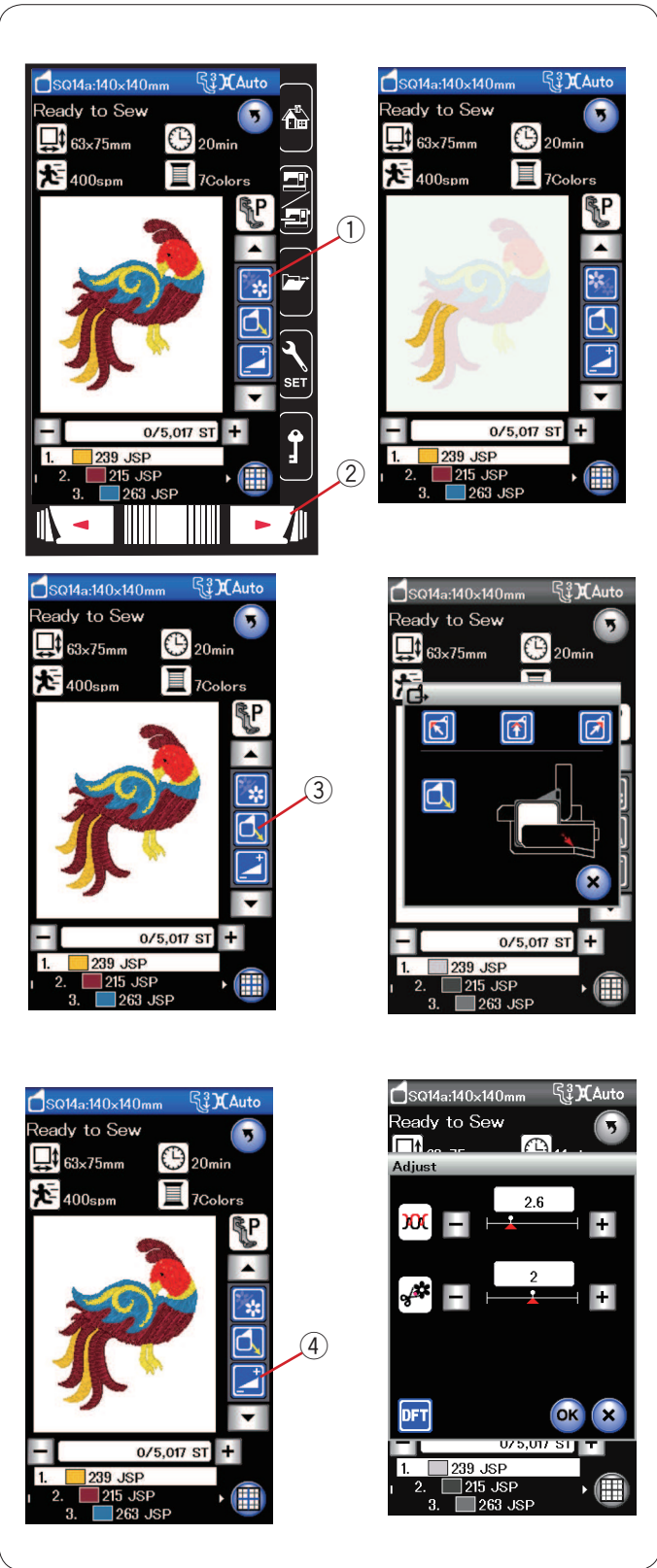

• **Color section key**

Press this key to show the complete image of the selected design or partial image of each color section only.

To view the next color section, press the next page key. You can sew only the specific color section by pressing the next page key until the desired section is displayed.

- ① Color section key
- ② Next page key

• **Hoop back key**

Raise the needle by pressing the needle up/down key, if the needle is in down position.

Press the hoop back key and hoop back option window will open.

Press one of the  keys to move the carriage to a standby position.

To move the carriage back to the home position, press the  key and a warning message will appear. Press the OK key and the carriage will go back to the home position.

- ③ Hoop back key

NOTE:

The feed dog will not be raised automatically.

• **Adjust key**

When pressing this key open the manual setting window. You can adjust the following settings in this window.

- ④ Adjust key

Auto thread tension level

Press the “+” or “-” key to adjust the thread tension to your preference.

Tail length of jump thread cutting

This option is valid when the “jump thread cutting length” setting is activated.

Press the “+” or “-” key to minimize the tail length of jump thread.

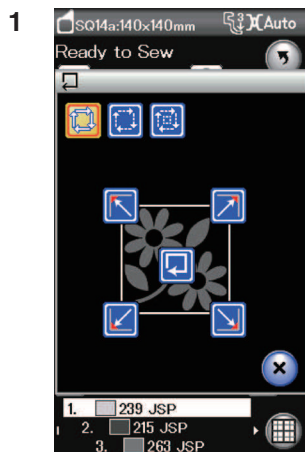
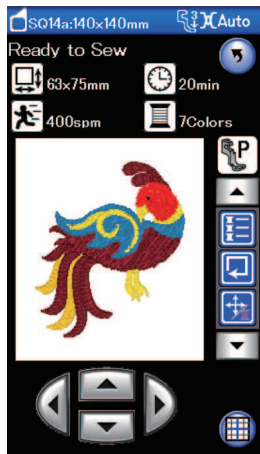

Pattern tracing

You can check the size of the embroidery area by tracing the pattern outline without stitching or with basting stitches.

Press the trace key and the trace option window will open.

① Trace key

The following 3 options are available:

1. Trace without stitching

Press the  key to open the trace without stitching window.

Press the trace key  to start tracing or press one of the keys to move the hoop to a corner.

2. Trace and baste (single)

Press the  key to open the trace and baste (single) window.

Press the start/stop button to start tracing with basting stitches.

3. Trace and baste (double)

Press the  key to open the trace and baste (double) window.

Press the start/stop button to start tracing with basting stitches. First, the machine bastes inside the pattern then traces the pattern outline with basting stitches.

NOTES:

The machine will baste around the embroidery area with a 5 mm allowance.

However, the allowance will not apply if the pattern spreads over the maximum limit of embroidery area.

To close the tracing option window, press the X key.

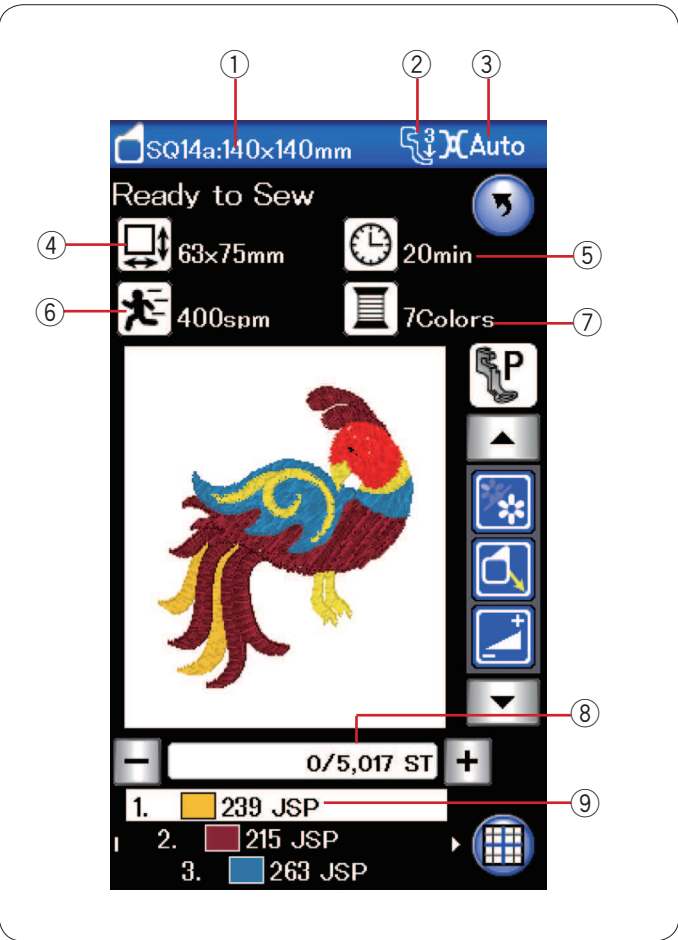

Pattern information

The visual touch screen displays the following details:

- ① Hoop size
- ② Presser foot pressure
- ③ Tension setting
- ④ Dimension of the design
- ⑤ Required sewing time
- ⑥ Maximum sewing speed
- ⑦ Number of thread colors (layers)
- ⑧ Stitch count
- ⑨ Thread color

Starting to sew embroidery

Select the desired pattern.

Press the jog/stitch key to show the jog keys.

- ① Jog/stitch key

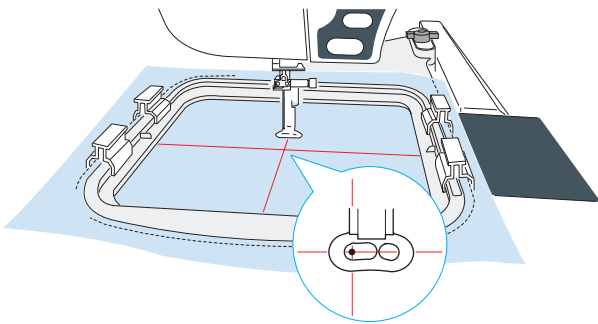
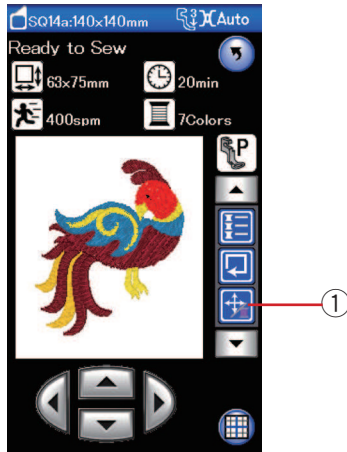

Adjust the hoop position with the jog keys so that the needle position comes right above the center of the centerlines on the fabric.

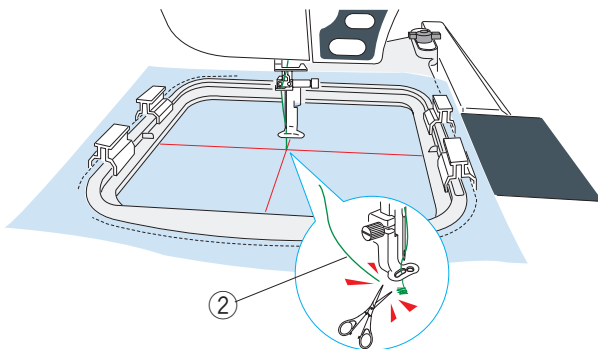

Press the start/stop button and sew 5 to 6 stitches.

Press the start/stop button again to stop the machine.

Raise the presser foot, cut the loose thread close to the beginning of the starting point.

- ② Loose thread

Lower the presser foot and press the start/stop button to start sewing again.

The machine will stop (and trim the threads if the auto thread cutting is activated) automatically when the first color section is finished.

Change the thread to the next color and sew the next section.

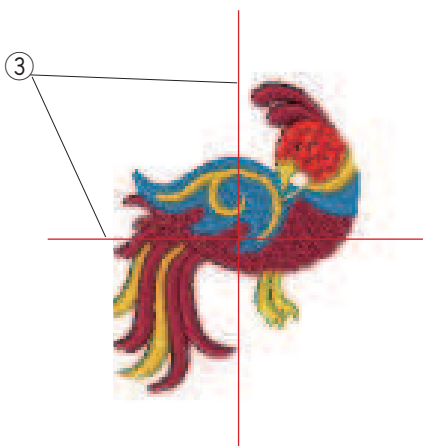

Sewing results

The embroidery pattern is sewn against the centerlines on the fabric as shown.

- ③ Centerlines on the fabric

NOTE:

Refer to page 115 for how to set auto thread cutting.

Fringe designs

Fringe designs are special patterns for creating fringed embroidery designs.

You can make attractive fringed designs easily.

Example: Fringe design SQ14a-125

Select fringe design SQ14a-125 and sew the pattern as you would sew a normal embroidery design.

Remove the fabric from the hoop.

Cut the needle threads along the red broken line at the outer edge of the pattern as shown.

Ruffle the threads to make fringe.

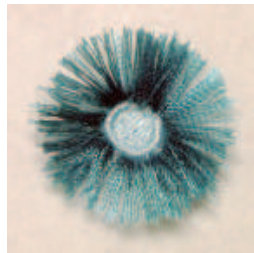
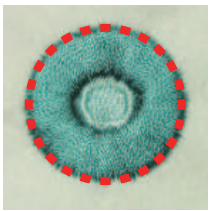
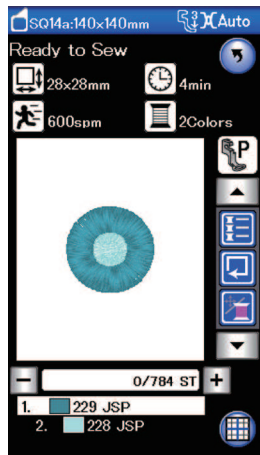

Example: Fringe design SQ14a-126

Select fringe design SQ14a-126 and sew the pattern as you would sew a normal embroidery design.

Remove the fabric from the hoop.

Cut the bobbin threads on the wrong side of the fabric along the red broken line as shown.

Pull the needle threads up and bring the loop ends to the right side of the fabric to make fringe.

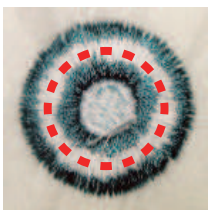
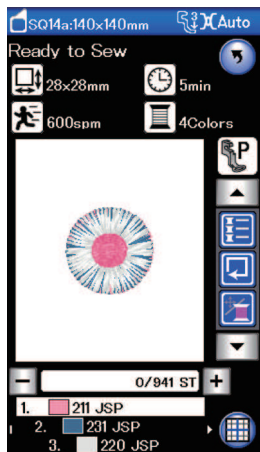

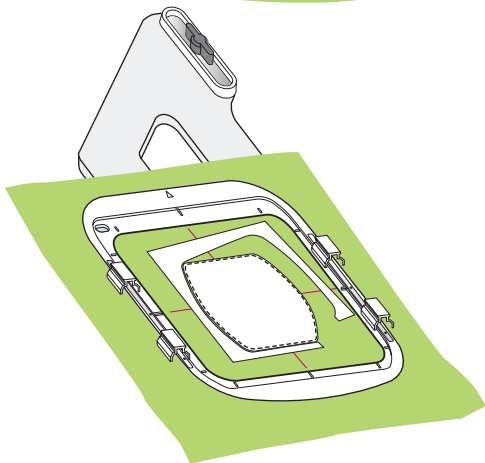
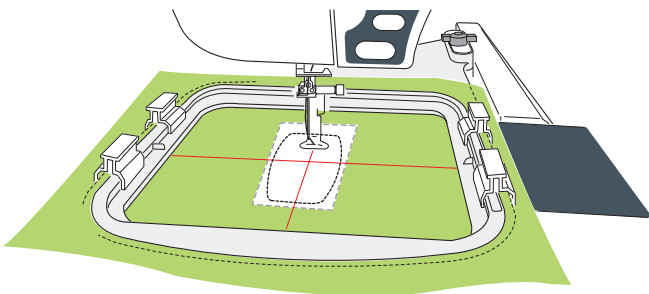
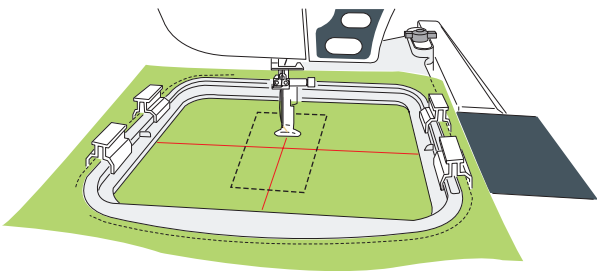

Applique designs

Patterns SQ14a-75, -76, -77, -127 and -128 are special designs for machine embroidery applique. You can attach applique piece to background fabric and embroider applique design at the same time.

Example: Applique design SQ14a-76

Prepare background fabric and applique fabric. Select applique design SQ14a-76 and set the background fabric to the hoop.

Attach the hoop to the carriage and press the trace key. Press the  key to select trace and baste (single). Start the machine to mark around embroidery design with basting stitches.

Cut the applique fabric the same size as the marked area. Place the applique piece on the marked area and sew the first section (color).

NOTE:

Pin the applique piece or use spray adhesive to fix the applique piece in place as necessary.

Remove the hoop from the machine, but do not unhoop the fabric.

Remove the basting stitches. Cut away the excess applique fabric as close to the seam line as possible.

Attach the hoop to the machine again. Sew the remaining sections (colors) of the applique design.

Alternative method

Prepare applique fabric larger than hoop size.
Set the applique fabric to the hoop.
Sew the first section (color) only.

Remove the hoop and unhoop the applique fabric. Cut the applique fabric along the stitching line to make an applique piece.

Prepare background fabric and set it to the hoop.
Attach the hoop to the carriage.
Press the previous page key to go back to the first section (color) and sew the first section (color) to mark the applique position.

① Previous page key

Place the applique piece on the background fabric and align the applique piece with the positioning mark. Fix the applique piece in place with a sticky tape or pin.

Sew the remaining sections (colors) of the applique design.

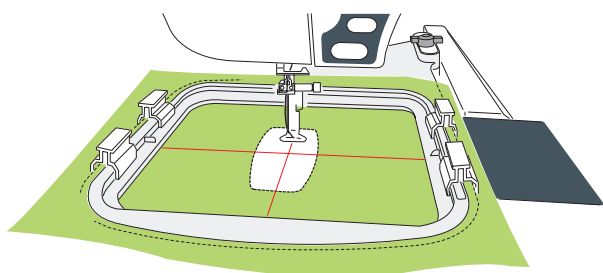
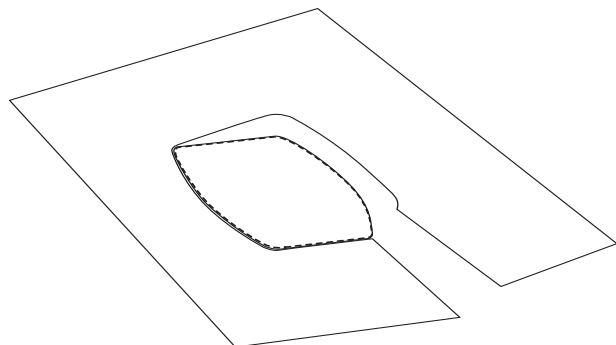
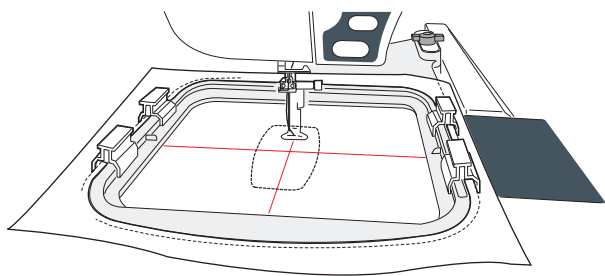

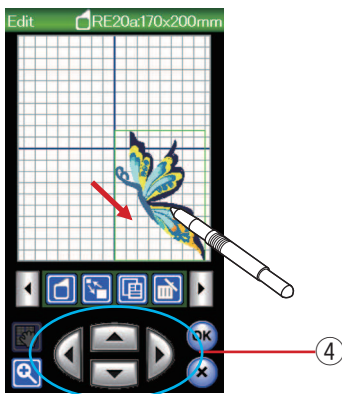
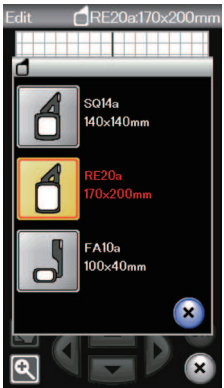
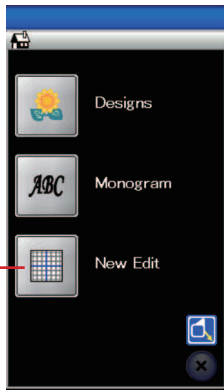

Editing Mode

In the editing mode, you can edit and combine patterns to create original embroidery designs.

Press the editing mode key and the editing window for the hoop RE20a will open.

① Editing mode key

You can select other hoop sizes.

Press the hoop selection key and the hoop selection window will open.

Press the hoop icon key to select the desired hoop.

② Hoop selection key

NOTES:

Free arm hoop FA10a is an optional item.

In the editing mode, you cannot select patterns larger than the size of the selected hoop.

Opening the embroidery designs

You can open the built-in designs, monogram, and designs from the USB flash drive in the editing window.

To open design patterns, press the home key.

Select the desired pattern from the design list (refer to page 93).

The screen will return to the editing window with the selected pattern displayed.

To add more design patterns or monogram in the editing window, press the home key again and select the desired pattern or monogram from the design list (refer to page 93-94)

③ Home key

Selecting the pattern to edit

To select the pattern to edit, press on the pattern image in the editing window.

The frame appears around the selected pattern.

Moving a pattern

To move the embroidery pattern in the editing window, press and drag the pattern to a desired location with the touch panel stylus or your fingertip.

NOTE:

Do not drag the pattern on the screen with a sharp pointed object.

You can move the selected pattern also by pressing the layout keys.

Press the layout keys to move the pattern to the desired position in the editing window.

④ Layout keys

The carriage will not move when you press the layout keys since the pattern position will move relative to the hoop, not to the machine.

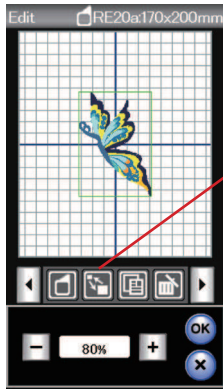

Resizing a pattern

Press the resize key to open the resize option window.

- ① Resize key

You can change the embroidery pattern size from 80% to 120% of the original size.

Press the “+” key to enlarge the pattern size.

Press the “-” key to reduce the pattern size.

The size will change 1% each time you press the plus or minus key. To change the size quickly, press and hold the “+” or “-” key.

Press the OK key to confirm the new size.

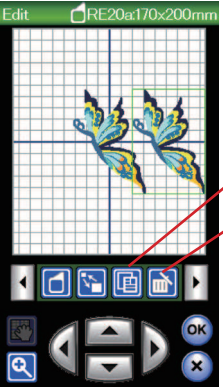

Duplicating a pattern

Press the duplicate key to make a copy of the selected pattern.

- ② Duplicate key

NOTE:

The duplicated pattern will be superimposed over the original pattern. Move the duplicate to show the original pattern.

Deleting the pattern

Select the design to delete.

Press the delete key to delete the selected pattern.

- ③ Delete key

Press the right arrow key to show the next set of editing tools.

- ④ Right arrow key

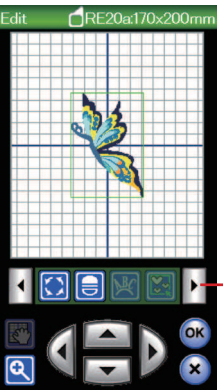

Rotating the pattern

Press the rotate key to open the rotation option window.

- ⑤ Rotate key

Press the **↺45** **↻1** **↻45** **↺45** keys to rotate the selected pattern 1 degree or 45 degrees, clockwise or counterclockwise.

Press the OK key to confirm.

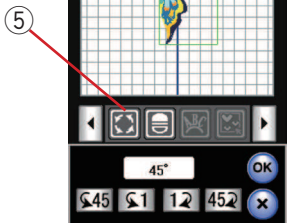

Flipping the pattern

Press the mirror image key to open the flip option window.

- ⑥ Mirror image key

Press the **↔** **↕** keys to flip the selected pattern horizontally or vertically.

Press the OK key to confirm.

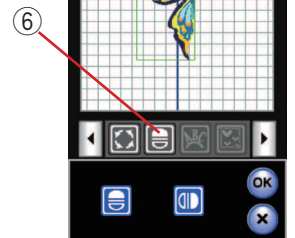

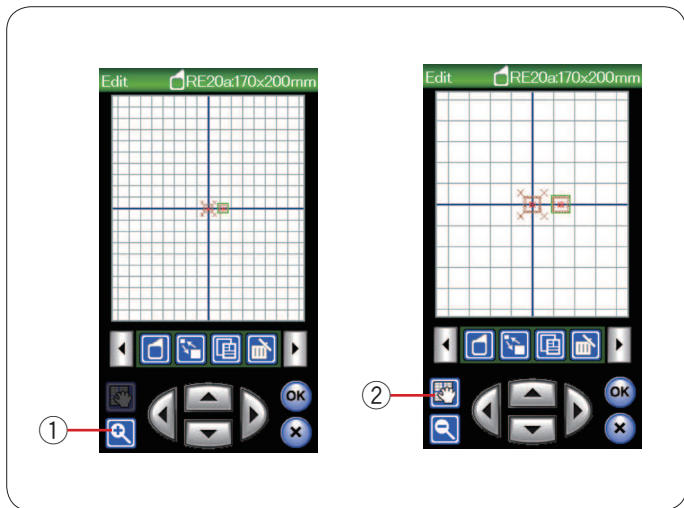

Zooming in the editing window

Press the zoom key to view the enlarged image in the editing window. Press the zoom key again to return to the original view.

- ① Zoom key

To scroll the window, press the scroll key and drag the window in the desired direction. To move the design, press the layout key.

- ② Scroll key

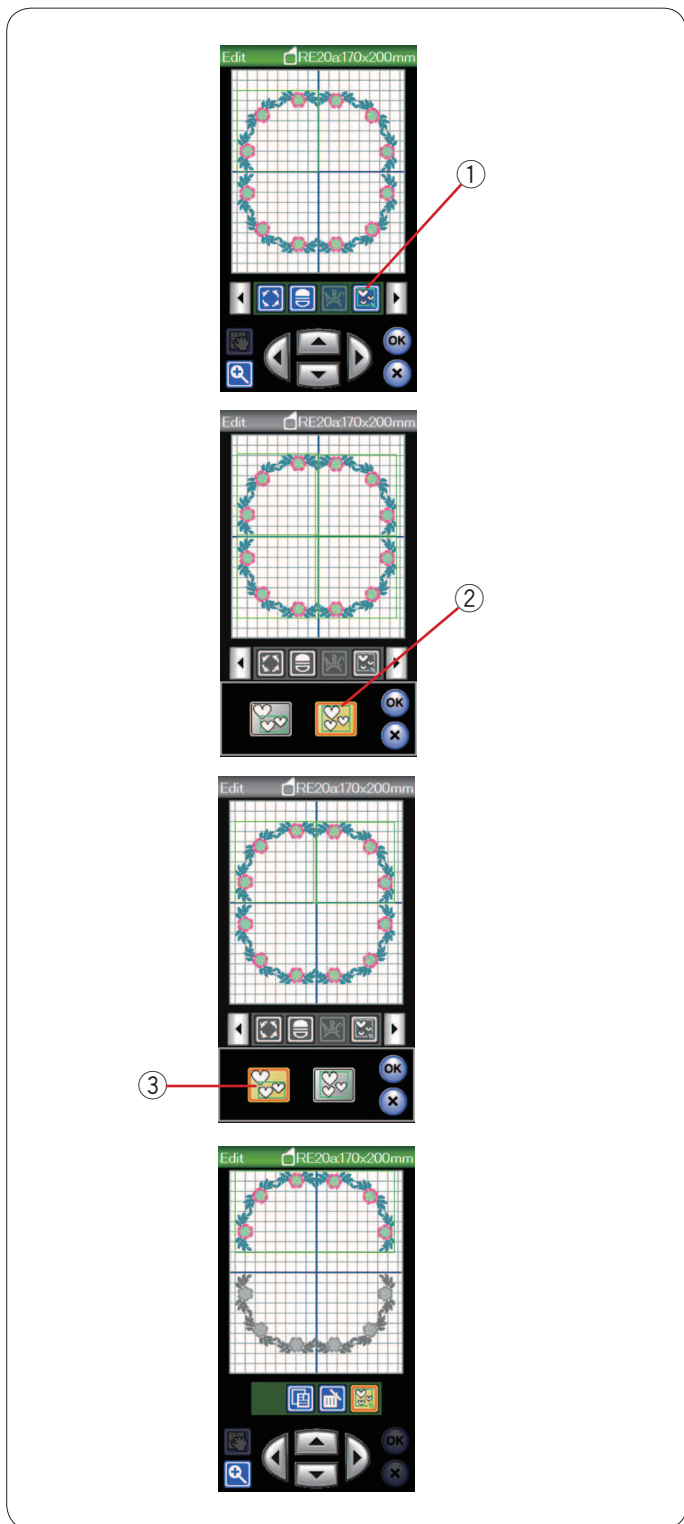

Grouping the patterns

You can group patterns together.

Press the group key and the grouping option window will open.

- ① Group key

Press the group all key and press the OK key to group all the patterns in the editing window.

- ② Group all key

If you wish to group the selected patterns only, press the group select key.

Select the desired patterns by pressing on the pattern images and press the OK key.

- ③ Group select key

When grouping the selected patterns only, the rest of the patterns are grayed out and cannot be selected.

The grouped patterns can be moved and duplicated as a unit.

To ungroup the patterns, press the group key again.

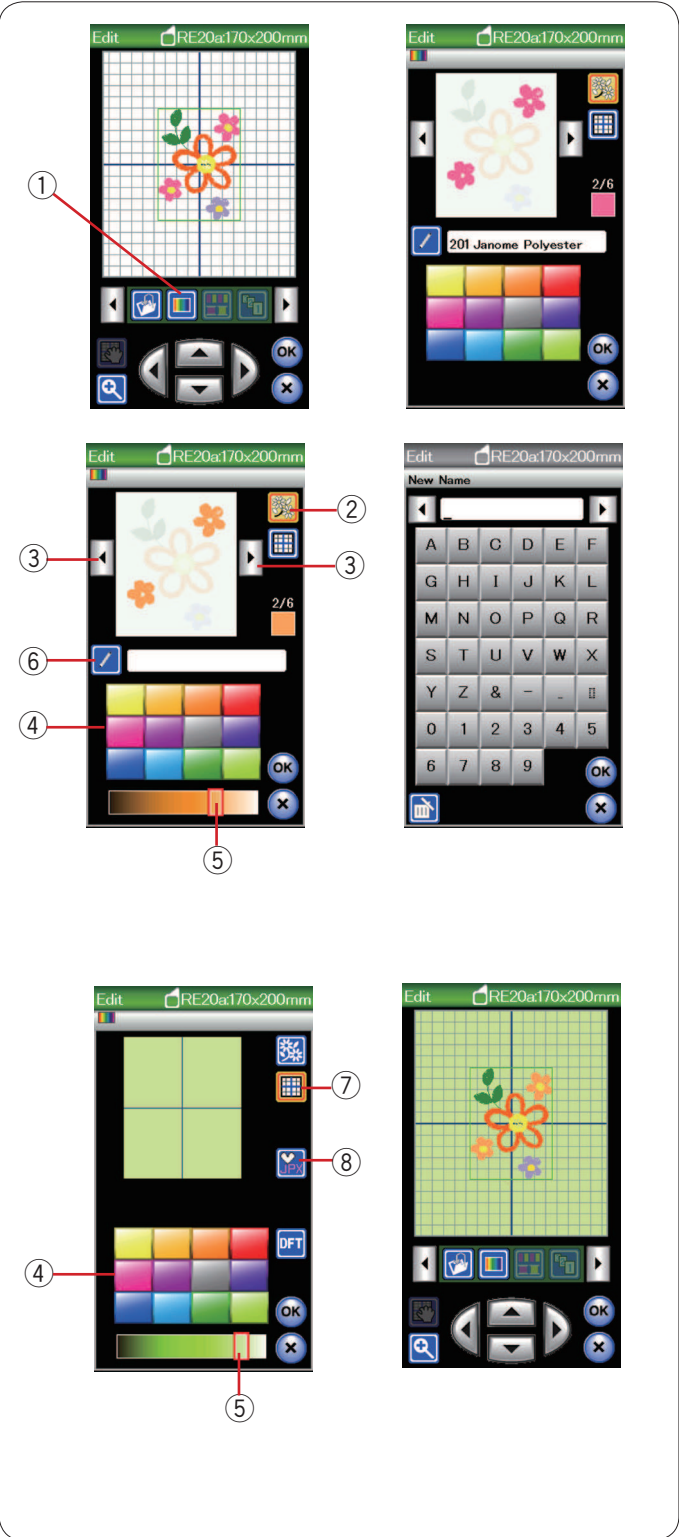
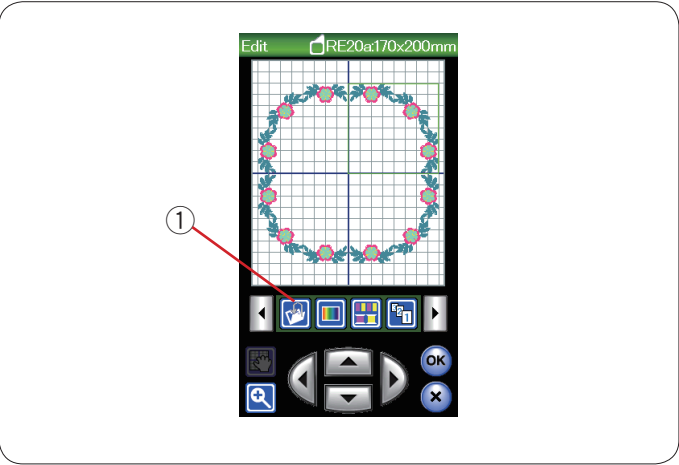

Saving a file

You can save original embroidery designs created in embroidery mode or programmed pattern combinations in ordinary sewing mode as files in the built-in memory and/or USB flash drive (refer to page 117).

- ① Save file key

Customizing the display colors

You can simulate the colors of the actual fabric and threads on the screen by customizing the colors of the design image and editing window.

Press the custom color key and the custom color window will open.

- ① Custom color key

If you wish to change the color of the design, press the design color key.

Press the scroll keys until the desired section is displayed in the preview window.

- ② Design color key
- ③ Scroll keys

To select the hue, press one of the 12 color tiles. To change the shade of the selected color, press and drag the slider to the left or right.

- ④ Color tiles
- ⑤ Slider

You can assign a name to the customized color for the color section by pressing the name key.

The assigned name will be displayed instead of the name and code of the thread color in the embroidery window.

- ⑥ Name key

To change the background color, press the background color key and select the desired color.

To select the hue, press one of the 12 color tiles. To change the shade of the selected color, press and drag the slider to the left or right.

- ⑦ Background color key

NOTE:
If a design in *.JPX format is open, you can display the background image in the editing window by pressing the background image key (refer to the instruction book of Digitizer MBX).

- ⑧ Background image key

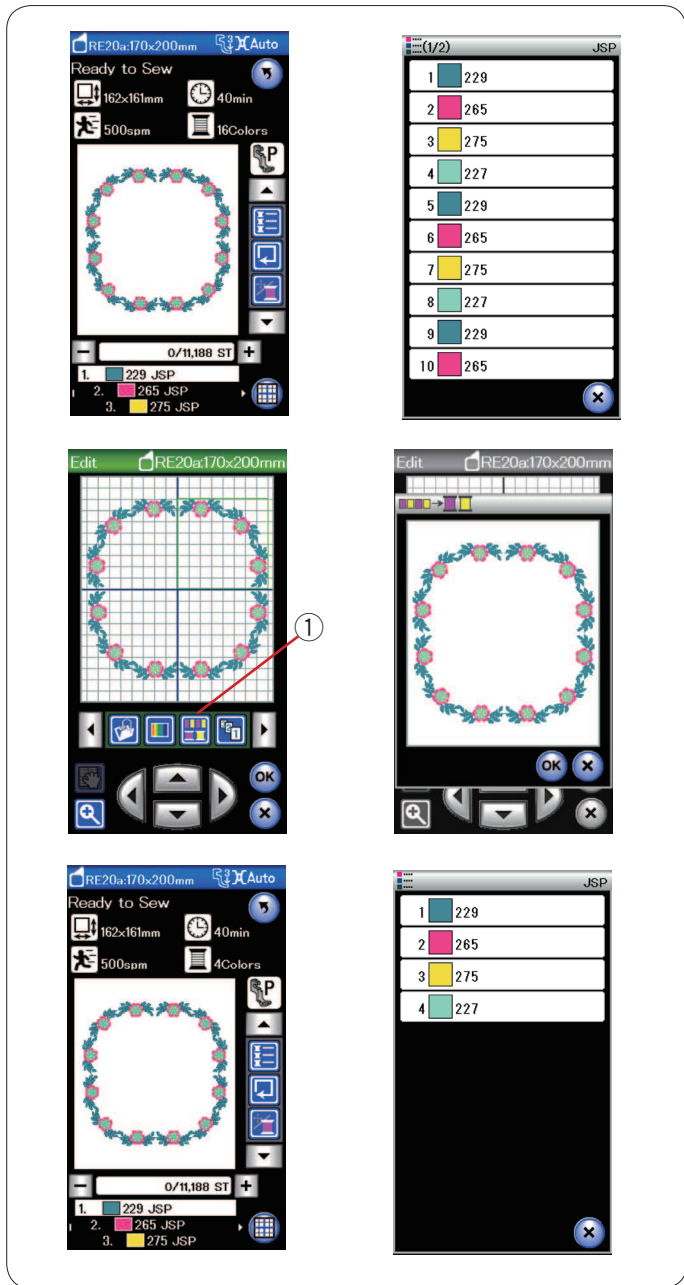

Color grouping

When combining duplicated patterns, you can reduce the number of color sections with color grouping.

For example, this combined design pattern has 16 color sections.

Press the color group key and the color grouping window will open.

Press the OK key to unite all color sections of the same color and the ready to sew window opens.

- ① Color group key

The number of the color sections is reduced to 4.

NOTE:

Color grouping will be cancelled when returning to the editing window.

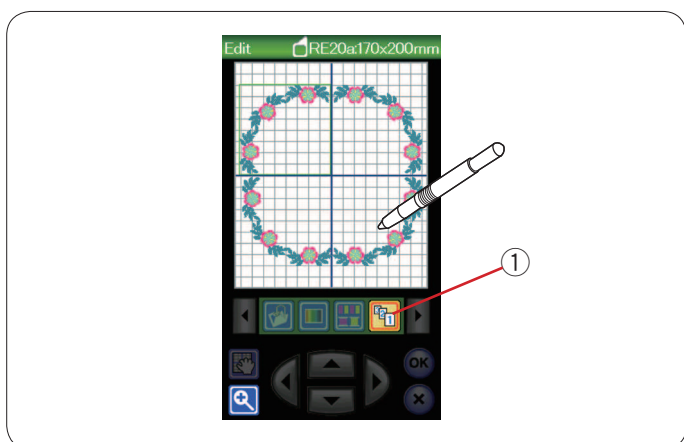

Sewing order

You can change the sewing order of a pattern combination.

Press the sewing order key and press on the images of the pattern one by one.

The patterns will be sewn in the order you press on the images.

Press the sewing order key again to return to the previous screen.

- ① Sewing order key

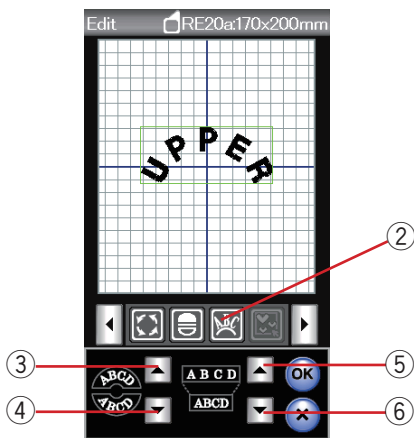
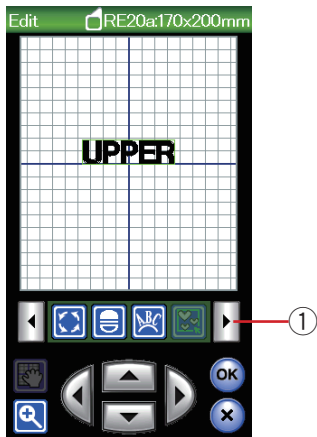
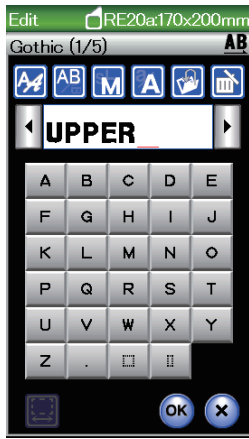

Monogramming in an arc

In the editing mode, you can make a monogram in an upper or lower arc.

Enter the characters and press the OK key.

The entered characters are displayed in the editing window.

Press the arrow key to view the other editing tools.

- ① Arrow key

Press the arc key and the arc layout window will open.

- ② Arc key

Press the upper arc key to make an upper arc.

- ③ Upper arc key

Press the lower arc key to make a lower arc.

- ④ Lower arc key

Press the enlarge key to make an arc longer.

- ⑤ Enlarge key

Press the shorten key to make an arc shorter.

- ⑥ Shorten key

Press the OK key to confirm.

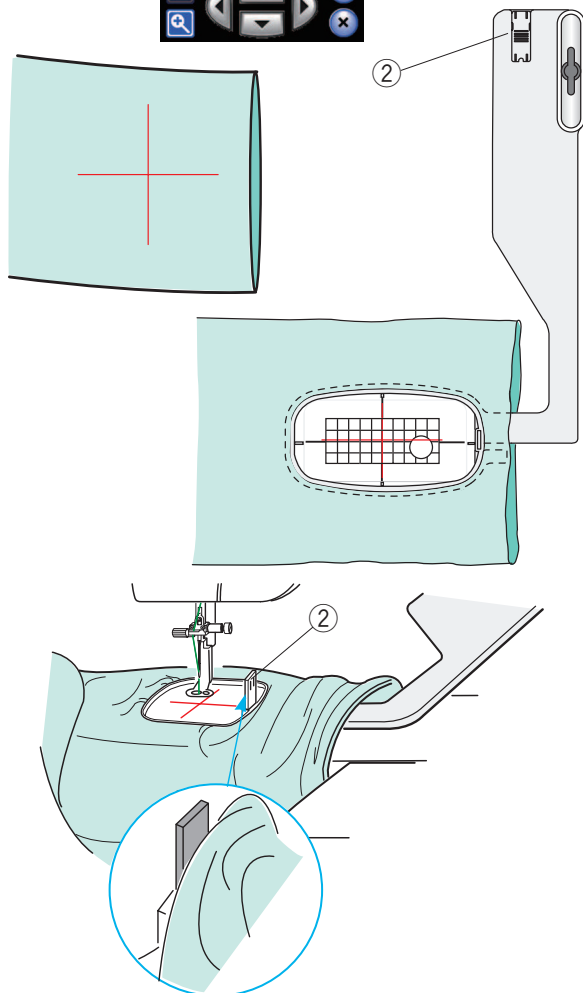
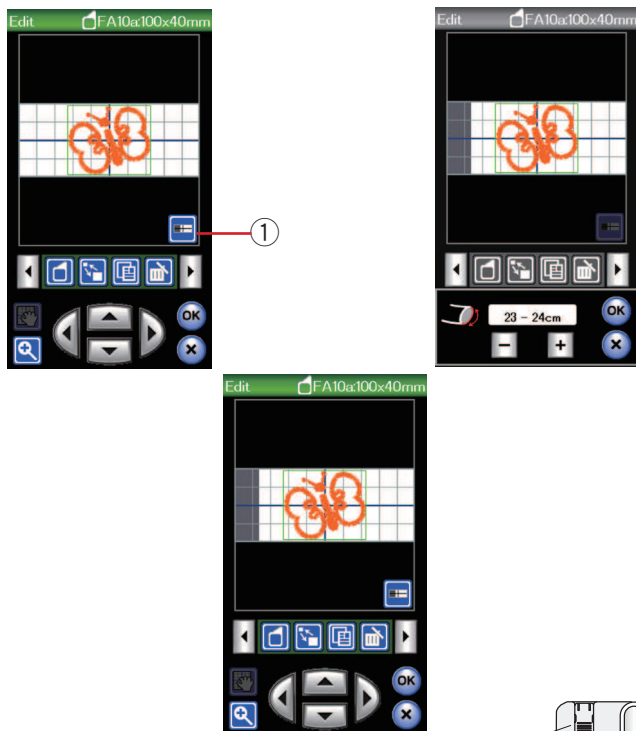
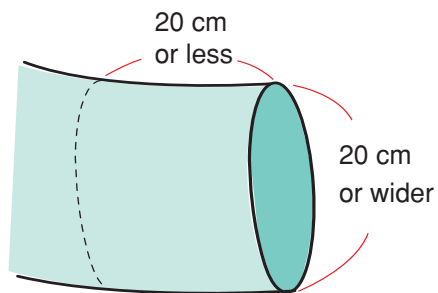

Free Arm Hoop (optional item)

The optional free arm hoop FA10a is specially designed for embroidering tubular garments such as sleeves, pant legs etc.

Check the opening size of the tubular portion of the garment. The opening width must be 20 cm (8") or wider. The area to be embroidered should be within 20 cm (8") from the opening.

Opening width:

If the opening width is 20–25 cm the embroidery area should be limited in order to prevent fabric from restraining hoop movement. Press the opening width key and select the opening width by pressing plus or minus key.

Press the OK key and the area limits will be indicated.

① Opening width key

Free arm embroidery

Draw centerlines on the fabric with tailor's chalk.

Open the editing window and select the hoop FA10a. Select small designs which can be opened.

Press the OK key to open the ready to sew window.

Remove the extension table.

Set the garment in the hoop FA10a as shown. Position the garment so that the centerlines match those on the template in the hoop.

Place the garment over the free arm of the machine and attach the hoop FA10a to the carriage.

Roll up the cuff so that it will not jam at the neck of the free arm.

Insert the blocking plate into the inner hoop to prevent the cuff from overlapping the embroidery area.

② Blocking plate

Press the start/stop button to sew making sure that the garment can move freely around the free arm.

Remove the hoop from the carriage when sewing is finished. Remove the garment from the free arm.

CUSTOMIZING MACHINE SETTINGS

Embroidery mode settings

Press the embroidery setting mode key (refer to page 75).

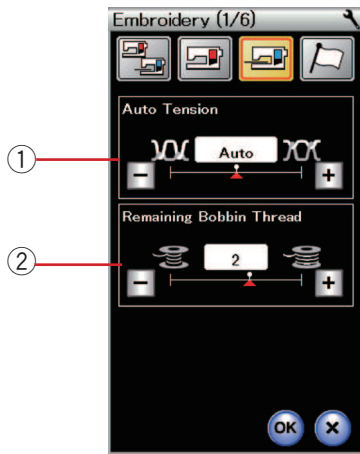

① Auto thread tension

The auto thread tension level can be adjusted with the “+” or “-” key. Increase the value when using the same threads on the bobbin and needle.

② Low bobbin thread warning

The low bobbin thread warning level can be adjusted with the “+” or “-” key.

Set the level to 3 or 4 when using thick threads for stitching lace designs or quilting. To turn this option off, press the “-” key until “OFF” shows in the window.

Press the next page key to go to the next menu.

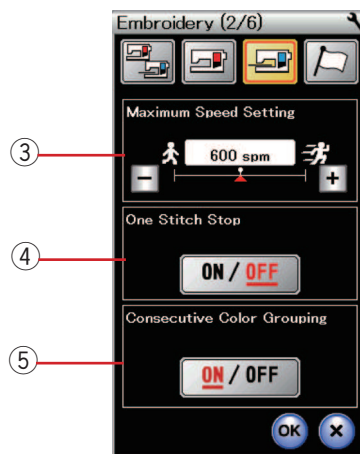

③ Maximum embroidery speed

The maximum embroidery sewing speed can be set from 400 to 800 spm in 100 spm intervals by pressing the “+” or “-” key. (Sewing speed can be varied with the speed control slider even while running the machine.)

NOTE:

Reduce the sewing speed when sewing patterns with narrow zigzag stitches that tend to warp at high speeds.

④ One stitch stop on/off

When this function is turned on, the machine sews one stitch and stops automatically so that you can bring the bobbin thread up before sewing.

⑤ Consecutive color grouping on/off

If an imported stitch data file or design files of a pattern combination contain consecutive sections in the same color, these sections are automatically grouped together as one section when opening the file or saving the pattern combination as the file or going to the ready to sew window. This function is invalid when combining the built-in designs and external sourced designs.

Turn this option off if you do not wish to group the sections together.

Press the next page key to go to the next menu.

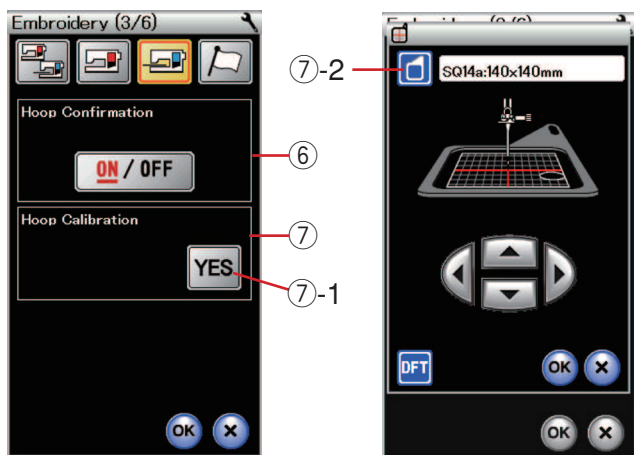

⑥ Hoop confirmation on/off

The hoop confirmation message will appear every time before opening the ready to sew window. However you can turn this option off by selecting off.

⑦ Hoop calibration

You can calibrate the center position of the hoops. You need to enter embroidery mode before opening the embroidery setting window.

Extend the carriage arm and press the YES key.

⑦-1 YES key

The carriage moves to the center position.

Press the hoop selection key to open the hoop selection window.

⑦-2 Hoop selection key

Select the hoop and attach it to the carriage. Set the template in the hoop. Adjust the hoop position by pressing the jog keys so that the needle is right above the hole in the template and press the OK key.

Press the next page key to go to the next menu.

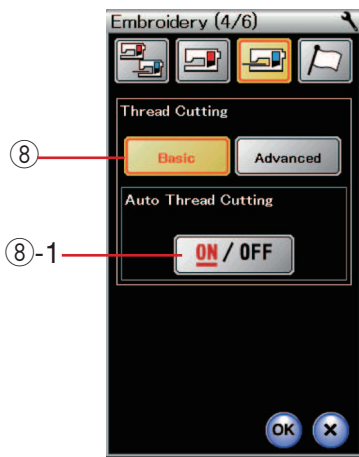

⑧ Auto thread cutting (basic)

The machine automatically trims the threads when it stops to change the thread to the next color when this option is turned on.

Press the ON/OFF key to turn this function on or off.

⑧-1 ON/OFF key

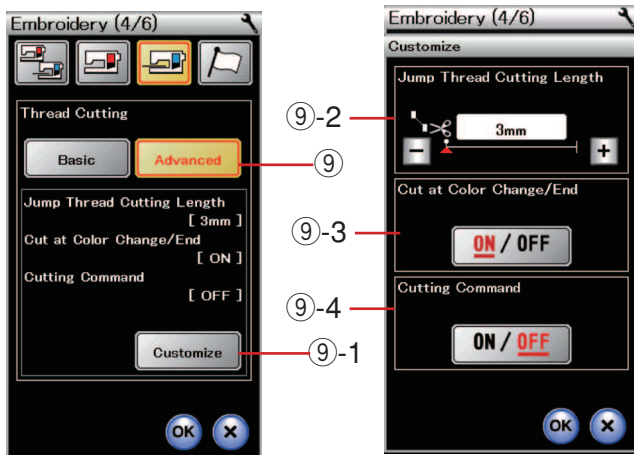

⑨ Auto thread cutting (advanced)

Press the customize key to open the advanced setting window.

⑨-1 Customize key

⑨-2 Jump thread cutting length

You can set the cutting length of jump threads by pressing the “+” or “-” key. The adjustable range is 3 mm to 30 mm or “OFF”.

You need to set the cutting length to “OFF” if you turn on the cutting command option.

⑨-3 Thread cutting at color change

The machine automatically trims the threads at the end of sewing and when it stops to change the thread to the next color if this option is turned on.

⑨-4 Cutting command on/off

If an imported embroidery stitch data file contains a trim code (cutting command), turn this option on to trim the threads at the trim code.

Press the next page key to go to the next menu.

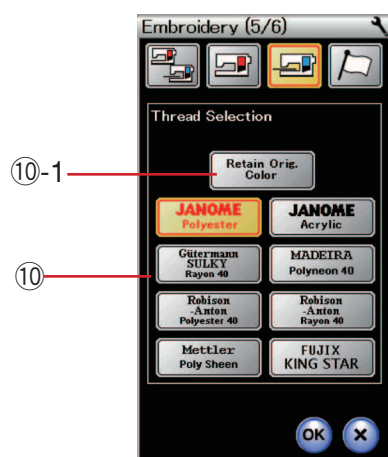

⑩ Thread selection

There are 8 types of embroidery thread to choose from.

Press the key of the thread you wish to use. The color code of the selected brand is shown on the color/part key along with the name of the color.

If you use imported embroidery stitch data containing proper thread information, press the retain original color key to retain this information.

⑩-1 Retain original color key

Press the next page key to go to the next menu.

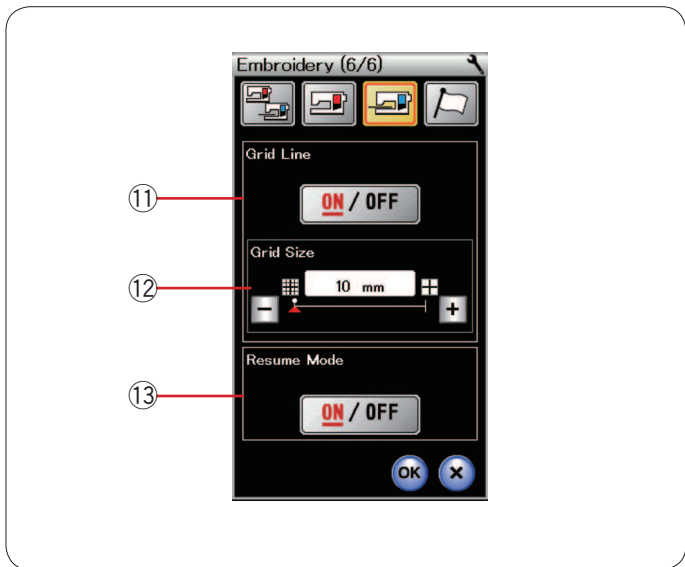

⑪ **Grid line on/off**

Turn this option on to show grid in the editing window or turn it off to hide the grid.

⑫ **Grid size**

You can change grid size by pressing the “+” or “-” key.

⑬ **Resume mode**

When Resume Mode is turned on, the last stitch sewn before turning the power off will resume when you turn the power on again.

When you turn the power on, the confirmation window opens. Press the OK key to resume the last stitch of the sewn pattern.

Press the OK Key to enable the new settings.

To return to the embroidery mode without changing the settings, press the X key.

FILE MANAGEMENT

Saving and Opening a File

Saving a file

You can save programmed pattern combinations in ordinary sewing mode or original embroidery designs created in embroidery mode as files in the built-in memory and/or USB flash drive.

Press the save file key and the save file window will open.

- ① Save file key

A folder labeled “Ord” (ordinary sewing mode) or “Embf” (embroidery mode) is displayed on the screen.

Press the built-in memory key or USB flash drive key to select the location to save the file.

- ② Built-in memory key
- ③ USB flash drive key

To select a folder, press the folder icon.

- ④ Folder icon

File names are assigned automatically in numerical order starting from M_001.....

Press the OK key and the file is saved in the selected folder.

To assign a particular name to the file, press the rename key.

- ⑤ Rename key

The keyboard window opens.

Enter a new name and press the OK key.

The file is saved under the new name.

When you attempt to save a file with a name that already exists, the confirmation message will appear.

Press the OK key to overwrite the existing file or press the X key if you do not want to overwrite it.



Ordinary sewing



Embroidery



Creating a new folder

Press the new folder key and the keyboard window will open.

- ① New folder key

Enter a folder name and press the OK key.

A new folder is created under the assigned name.

Deleting a file or folder

Press the delete key and select the file or folder to delete.

- ② Delete key

A confirmation message appears.

Press the OK key to delete the file or folder.



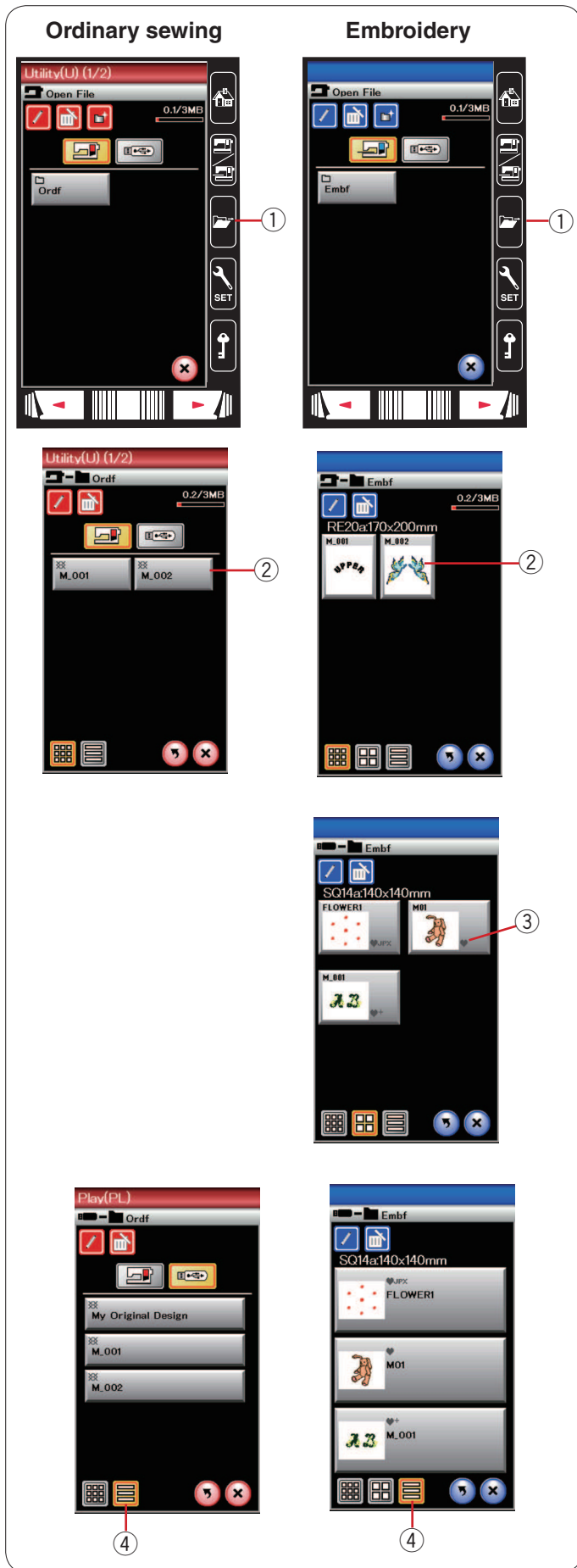

Opening the file

To open the saved files, press the open file key to open the open file window.

- ① Open file key

Select the folder location, either the built-in memory or USB flash drive.

Open the folder that contains the desired file by pressing the folder icon.

The file list of the selected folder is displayed.





To open the file, press the file icon.

- ② File icon

In the embroidery mode, file attributes can be viewed when pressing  key to show the large file icon.

- ③ File attribute

There are 4 file attributes as follows:

-  : *.JEF (Janome embroidery format)
-  : *.JEF+ (editable Janome embroidery format)
-  : *.JPX (*.JEF+ with a background bitmap image)
-  : *.JPX (*.JEF+ with hoop FA10a limit)

Viewing file names

In the file list window, the file icon key can show up to 8 characters of the file name.

If the file name is long and cannot be shown, press the long icon key  to show the long file name.

- ④ Long icon key

File names in Russian letters can also be shown when the long icon key is pressed.

Ordinary sewing

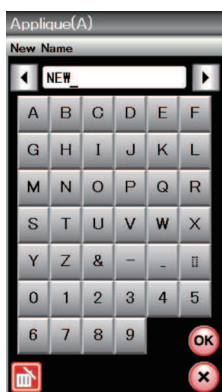

Embroidery

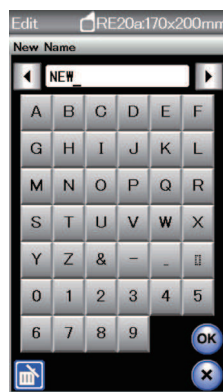

Changing a name of the file or folder

Press the save file key and select the file you wish to change its name.

Press the rename key.

The name of the file or folder will change.

- ① Rename key

The keyboard window will open. Enter a new name and press the OK key.

If you entered a name that already exists, a confirmation message will appear.

Press the X key and enter another name.

CARE AND MAINTENANCE

Cleaning the Hook Area

Clean the hook area at least once a month.

Remove the needle plate (refer to page 19).

Turn the power switch off and unplug the machine.

Remove the needle and presser foot.

NOTE:

Do not dismantle the machine in any way other than as explained in this section.

Take out the bobbin and bobbin holder.

- ① Bobbin holder

Clean the bobbin holder with a lint brush.

Apply a few drops of the bobbin holder cleaner (included in the standard accessories) to a soft cloth and wipe the bobbin holder both inside and outside.

- ② Lint brush
- ③ Soft cloth

Clean the feed dog and auto thread cutter device with the lint brush.

- ④ Feed dog
- ⑤ Auto thread cutter device

Clean the inside and lip of the hook race with a soft cloth.

Insert the bobbin holder so that the knob fits next to the stopper in the hook race.

Insert the bobbin.

- ⑥ Knob
- ⑦ Stopper

Attach the needle plate, presser foot and needle.

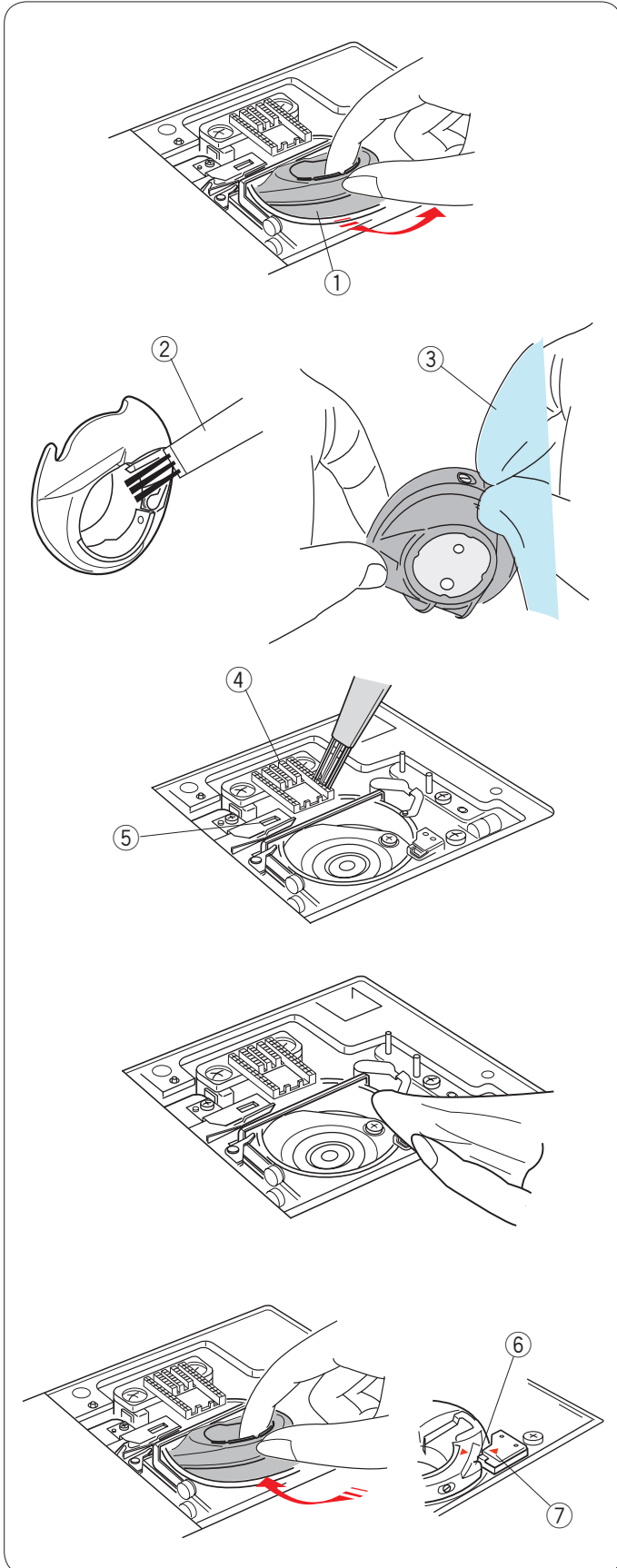

Cleaning the Inside of the Thread Guide

Clean the inside of the thread guide plate under the top cover at least once a month.

Remove the needle thread and remove the thread guide plate by pulling it up.

- ① Thread guide plate

Remove lint and dust from the brush on the underside of the thread guide plate using a lint brush.

- ② Brush on the thread guide plate

Clean the area around and under the pre-tension leaf with the lint brush.

- ③ Pre-tension leaf

Set the thread guide plate on the machine, inserting the tenons into the slots. Push the thread guide plate down to snap it in place.

- ④ Tenon

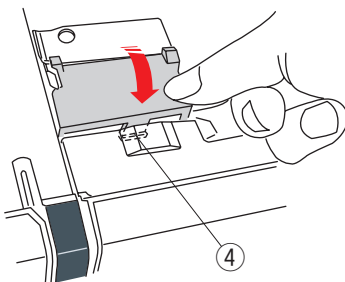
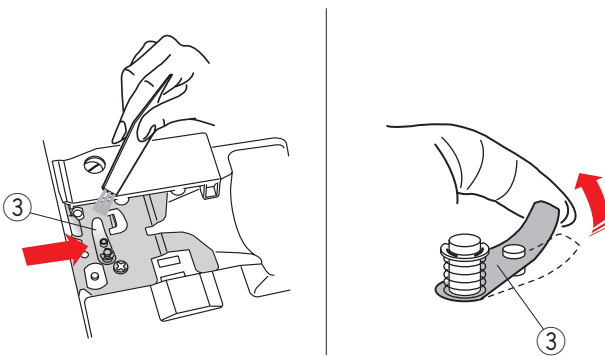
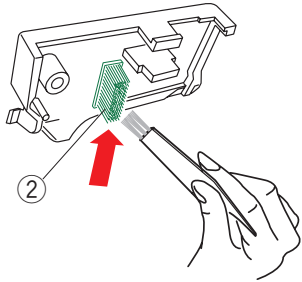
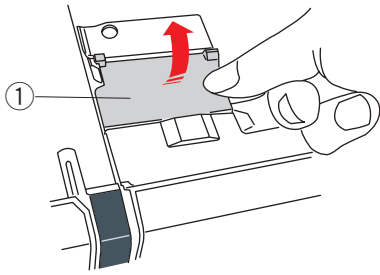

Troubleshooting

Problem	Cause	Reference
The machine is noisy.	<ol style="list-style-type: none"> 1. Thread is jammed in the hook area. 2. The feed dog is packed with lint. 	<p>See page 121. See page 121.</p>
The needle thread breaks.	<ol style="list-style-type: none"> 1. The needle thread is not threaded properly. 2. The needle thread tension is too tight. 3. The needle is bent or blunt. 4. The needle is inserted incorrectly. 5. The thread is too heavy for the needle. 6. The needle thread was not set in the thread holder when embroidery sewing started. 	<p>See page 13. See page 34. See page 16. See page 16. See page 16. See page 92.</p>
The bobbin thread breaks.	<ol style="list-style-type: none"> 1. The bobbin thread is not threaded properly in the bobbin holder. 2. Lint has collected in the bobbin holder. 3. The bobbin is damaged and does not turn smoothly. 	<p>See page 12. See page 121. Replace the bobbin.</p>
The needle breaks.	<ol style="list-style-type: none"> 1. The needle is inserted incorrectly. 2. The needle is bent or blunt. 3. The needle clamp screw is loose. 4. The needle thread tension is too tight. 5. The needle is too fine for the fabric being sewn. 	<p>See page 16. See page 16. See page 16. See page 34. See page 16.</p>
Visual Touch Screen is not clear.	<ol style="list-style-type: none"> 1. The contrast of the screen is not adjusted properly. 	<p>See page 76.</p>
Skipped stitches	<ol style="list-style-type: none"> 1. The needle is inserted incorrectly. 2. The needle is bent or blunt. 3. The needle and/or threads are not suitable for the fabric being sewn. 4. A blue tip needle is not being used for sewing stretch, very fine and synthetics. 5. The needle thread is not threaded properly. 6. The needle is defective (rusted, burr on needle eye or tip). 7. The embroidery hoop is not set properly. 8. The fabric is not stretched tightly enough on the embroidery hoop. 9. A purple tip needle is not being used for sewing thick fabrics, denims and across the hem. 	<p>See page 16. See page 16. See page 16. See page 16. See page 13. Change the needle. See page 92. See page 91. See page 16.</p>
Seam puckering	<ol style="list-style-type: none"> 1. The needle tension is too tight. 2. The needle thread or the bobbin thread is not threaded correctly. 3. The needle is too heavy for the fabric being sewn. 4. The stitch length is too long for the fabric. 5. The stitch width is too wide. 6. The fabric is not stretched tightly enough on the embroidery hoop. 	<p>See page 34. See pages 12-13. See page 16. Make stitches shorter. Reduce the stitch width. See page 91.</p>

Problem	Cause	Reference
The cloth is not feeding smoothly.	<ol style="list-style-type: none"> 1. The feed dog is packed with lint. 2. The stitches are too fine. 3. The feed dog is lowered. 	<p>See page 121. Make stitches longer. See page 21.</p>
The machine does not run.	<ol style="list-style-type: none"> 1. The machine is not plugged in. 2. A thread is caught in the hook race. 3. The start/stop button is used for ordinary sewing with the foot control plugged in. 	<p>See page 6. See page 121. See page 8.</p>
Crunching sound occurs when running the machine.	<ol style="list-style-type: none"> 1. Something is caught between the carriage and the arm. 2. The carriage is hitting something around the machine 	<p>Remove the object. See page 83.</p>
Patterns are distorted.	<ol style="list-style-type: none"> 1. The needle thread tension is too loose. 2. The stitch length is not suitable for the fabric being sewn. 3. Feed balancing dial is not properly set. 4. Interfacing is not used for sewing stretch and very fine fabrics. 5. The embroidery hoop attaching knob is loose. 6. The embroidery hoop is hitting something around the machine. 7. The fabric is not stretched tightly enough on the embroidery hoop. 8. The fabric is caught or trapped when sewing embroidery. 	<p>See page 34. See page 33. See page 82. Use an interfacing.</p> <p>See page 92. See page 83.</p> <p>See page 91.</p> <p>Stop the machine and free the fabric.</p>
The automatic buttonhole stitches are not balanced.	<ol style="list-style-type: none"> 1. The stitch length is not suitable for the fabric being sewn. 2. The feed balancing dial is not set properly. 3. Interfacing is not being used with stretch fabric. 	<p>See page 39. See page 82. Use an interfacing.</p>
Pattern selection keys do not work.	<ol style="list-style-type: none"> 1. The electronic control circuit is not working correctly. 2. The key position is out of alignment 	<p>Turn the switch off and turn it on again. See page 76.</p>
Threads frequently bunch up on the underside of the stippling design pattern.	<ol style="list-style-type: none"> 1. The minimum length of the jump thread cutting is too short. 	<p>See page 115.</p>

To carry the sewing machine, hold the carrying handle with your hand, and support the sewing machine with the other hand.

Clean the outside of the machine with a soft cloth. Do not use chemical solvents.

Store the machine and accessories in cool and dry place.

Do not store the machine in a area of high humidity, near a radiator or in direct sunlight.

The power supply cord, foot control and embroidery hoops can be stored in the semi-hard fabric cover.

Make sure to store the embroidery carriage arm before turning off the power switch.

STITCH CHART

Ordinary Sewing

Utility (U)

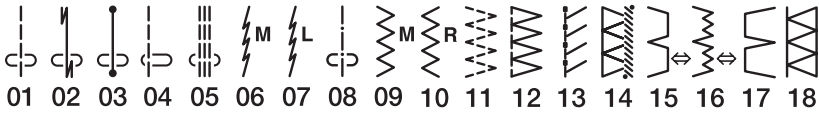

Buttonhole (B)



Applique (A)

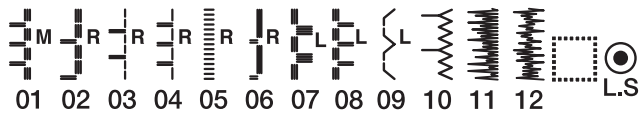

Heirloom (H)

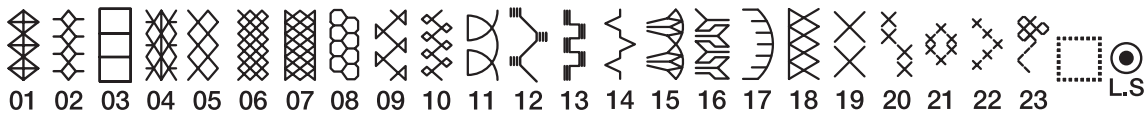

Quilt (Q)

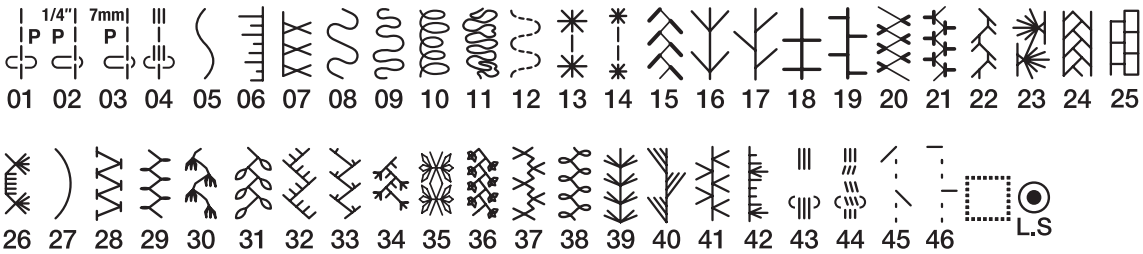

STITCH CHART

Ordinary Sewing

Satin (S)



Bridge (BR)

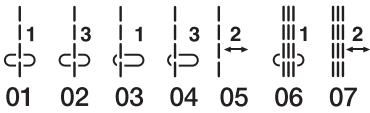

Decorative (D)

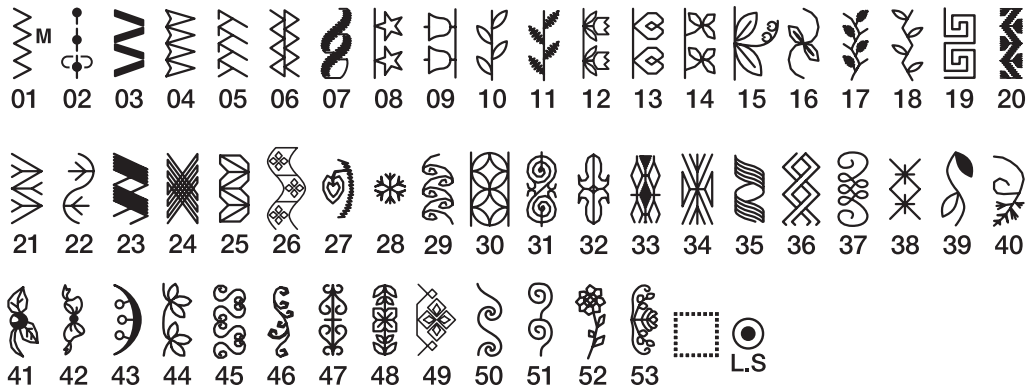

Long (L)



Pictograph (P)

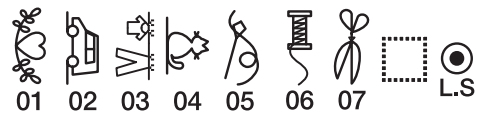

Play (PL)

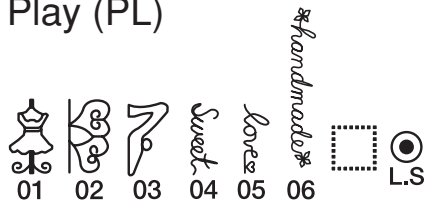

STITCH CHART Ordinary Sewing

Block

A	B	C	D	E	F	G	H	I	J	K	L	M	N					
O	P	Q	R	S	T	U	V	W	X	Y	Z	.	□	□				
a	b	c	d	e	f	g	h	i	j	k	l	m	n					
o	p	q	r	s	t	u	v	w	x	y	z	.	□	□				
1	2	3	4	5	6	7	8	9	0	&	-	\$	@	.	.			
,	?	¿	!	¡	'	'	<	>	()	-	+	=	/	//	%	~	:
À	Á	Â	Ã	Ä	Å	Æ	Ç	È	É	Ê	Ë	Ì	Í	Î	Ï	Ñ		
Ò	Ó	Ô	Õ	Ö	Ø	Ù	Ú	Û	Ü	ß	À	Ć	Ę	Ğ	İ	İ		
Ł	Ń	Œ	Ś	Ş	Ž	Ž												
à	á	â	ã	ä	å	æ	ç	è	é	ê	ë	ì	í	î	ï	ñ		
ò	ó	ô	õ	ö	ø	ù	ú	û	ü	ß	à	ć	ę	ğ	ı	ij		
ł	ń	œ	ś	ş	ž	ž												

Script

A	B	C	D	E	F	G	H	I	J	K	L	M	N					
Q	P	Q	R	S	T	U	V	W	X	Y	Z	.	□	□				
a	b	c	d	e	f	g	h	i	j	k	l	m	n					
o	p	q	r	s	t	u	v	w	x	y	z	.	□	□				
1	2	3	4	5	6	7	8	9	0	&	-	\$	@	.	.			
,	?	¿	!	¡	'	'	<	>	()	-	+	=	/	//	%	~	:
À	Á	Â	Ã	Ä	Å	Æ	Ç	È	É	Ê	Ë	Ì	Í	Î	Ï	Ñ		
Ò	Ó	Ô	Õ	Ö	Ø	Ù	Ú	Û	Ü	ß	À	Ć	Ę	Ğ	İ	İ		
Ł	Ń	Œ	Ś	Ş	Ž	Ž												
à	á	â	ã	ä	å	æ	ç	è	é	ê	ë	ì	í	î	ï	ñ		
ò	ó	ô	õ	ö	ø	ù	ú	û	ü	ß	à	ć	ę	ğ	ı	ij		
ł	ń	œ	ś	ş	ž	ž												

Block (9 mm)

A	B	C	D	E	F	G	H	I	J	K	L	M	N					
O	P	Q	R	S	T	U	V	W	X	Y	Z	.	□	□				
1	2	3	4	5	6	7	8	9	0	&	-	\$	@	.	.			
,	?	¿	!	¡	'	'	<	>	()	-	+	=	/	//	%	~	:

DESIGN CHART Embroidery

Pattern images are not to scale.

Favorite Designs



MADE WITH MY Created By Produced By

(SQ14a)

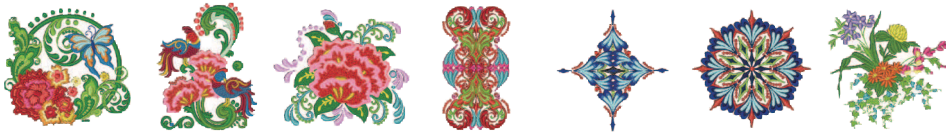

(RE20a)

Geometric Designs

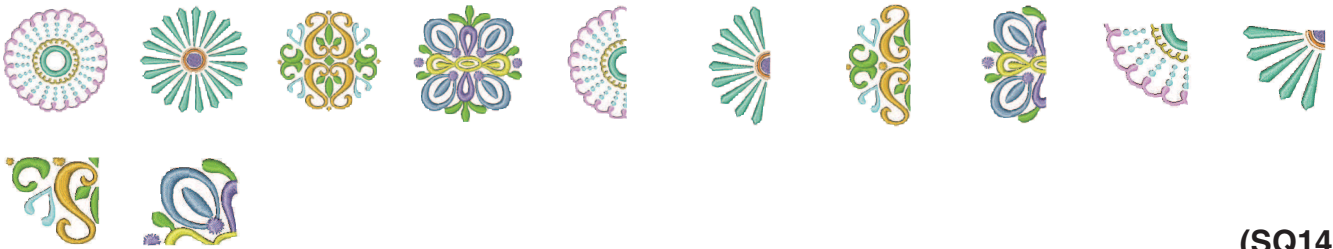

(SQ14a)

Pantry Designs



(SQ14a)



(RE20a)

DESIGN CHART

Embroidery

Pattern images are not to scale.

Monochrome Designs

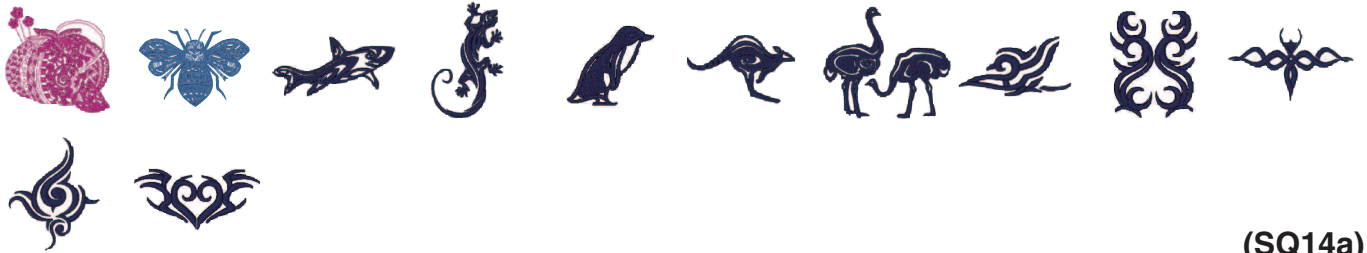

(SQ14a)



(RE20a)

Cross Stitch Designs

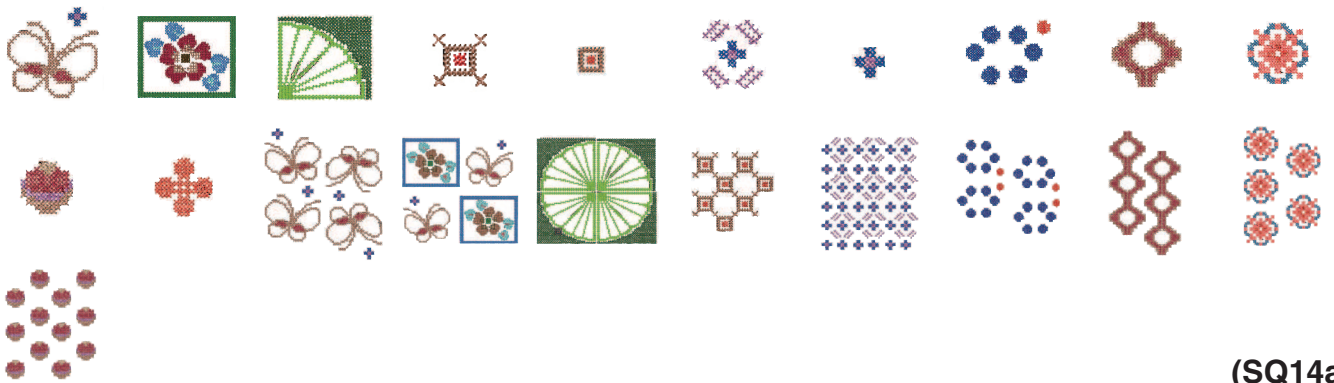

(SQ14a)

Quilting Designs

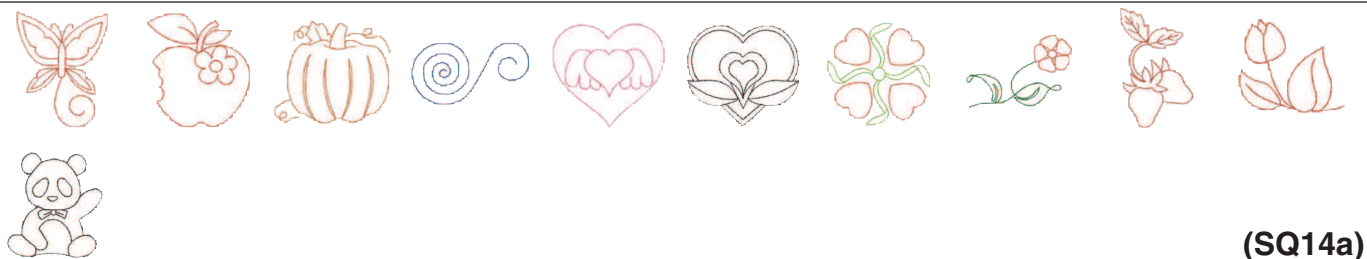

(SQ14a)



(RE20a)

Fringe Designs



(SQ14a)



(RE20a)

DESIGN CHART
Embroidery

Pattern images are not to scale.

Floral Alphabet Designs



(SQ14a)

Calibration Pattern



DESIGN CHART

Embroidery

Gothic

A	B	C	D	E	F	G	H	I	J	K	L	M	N	
O	P	Q	R	S	T	U	V	W	X	Y	Z	.	□	□
a	b	c	d	e	f	g	h	i	j	k	l	m	n	
o	p	q	r	s	t	u	v	w	x	y	z	.	□	□
1	2	3	4	5	6	7	8	9	0	&	_	\$	@	
.	•	,	?	¿	!	ı	'	'	<	>	()	-	+
=	/	//	%	~	:									
À	Á	Â	Ã	Ä	Å	Æ	Ç	È	É	Ê	Ë	Ì	Í	Î
Ï	Ñ	Ò	Ó	Ô	Õ	Ö	Ø	Ù	Ú	Û	Ü	ß	À	Ć
Ę	Ĝ	Ĭ	Ĵ	Ł	Ń	Œ	Ś	Ş	Ž	Ž				
à	á	â	ã	ä	å	æ	ç	è	é	ê	ë	ì	í	î
ï	ñ	ò	ó	ô	õ	ö	ø	ù	ú	û	ü	ß	à	ć
ę	ğ	ı	ĵ	ł	ń	œ	ś	ş	ž	ž				

Script

A	B	C	D	E	F	G	H	I	J	K	L	M	N	
O	P	Q	R	S	T	U	V	W	X	Y	Z	.	□	□
a	b	c	d	e	f	g	h	i	j	k	l	m	n	
o	p	q	r	s	t	u	v	w	x	y	z	.	□	□
1	2	3	4	5	6	7	8	9	0	&	_	\$	@	
.	•	,	?	¿	!	ı	'	'	<	>	()	-	+
=	/	//	%	~	:									
À	Á	Â	Ã	Ä	Å	Æ	Ç	È	É	Ê	Ë	Ì	Í	Î
Ï	Ñ	Ò	Ó	Ô	Õ	Ö	Ø	Ù	Ú	Û	Ü	ß	À	Ć
Ę	Ĝ	Ĭ	Ĵ	Ł	Ń	Œ	Ś	Ş	Ž	Ž				
à	á	â	ã	ä	å	æ	ç	è	é	ê	ë	ì	í	î
ï	ñ	ò	ó	ô	õ	ö	ø	ù	ú	û	ü	ß	à	ć
ę	ğ	ı	ĵ	ł	ń	œ	ś	ş	ž	ž				

Cheltenham

A	B	C	D	E	F	G	H	I	J	K	L	M	N	
O	P	Q	R	S	T	U	V	W	X	Y	Z	.	□	□
a	b	c	d	e	f	g	h	i	j	k	l	m	n	
o	p	q	r	s	t	u	v	w	x	y	z	.	□	□
1	2	3	4	5	6	7	8	9	0	&	_	\$	@	
.	•	,	?	¿	!	ı	'	'	<	>	()	-	+
=	/	//	%	~	:									
À	Á	Â	Ã	Ä	Å	Æ	Ç	È	É	Ê	Ë	Ì	Í	Î
Ï	Ñ	Ò	Ó	Ô	Õ	Ö	Ø	Ù	Ú	Û	Ü	ß	À	Ć
Ę	Ĝ	Ĭ	Ĵ	Ł	Ń	Œ	Ś	Ş	Ž	Ž				
à	á	â	ã	ä	å	æ	ç	è	é	ê	ë	ì	í	î
ï	ñ	ò	ó	ô	õ	ö	ø	ù	ú	û	ü	ß	à	ć
ę	ğ	ı	ĵ	ł	ń	œ	ś	ş	ž	ž				

2 Letters / 3 Letters



Border



Normal Sew



