

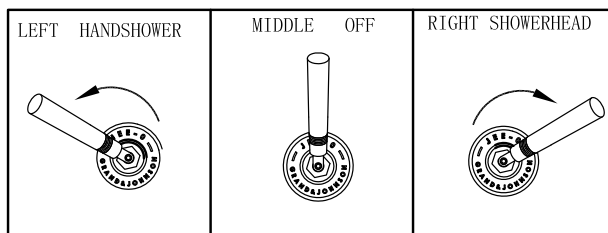

JEE-O soho 02

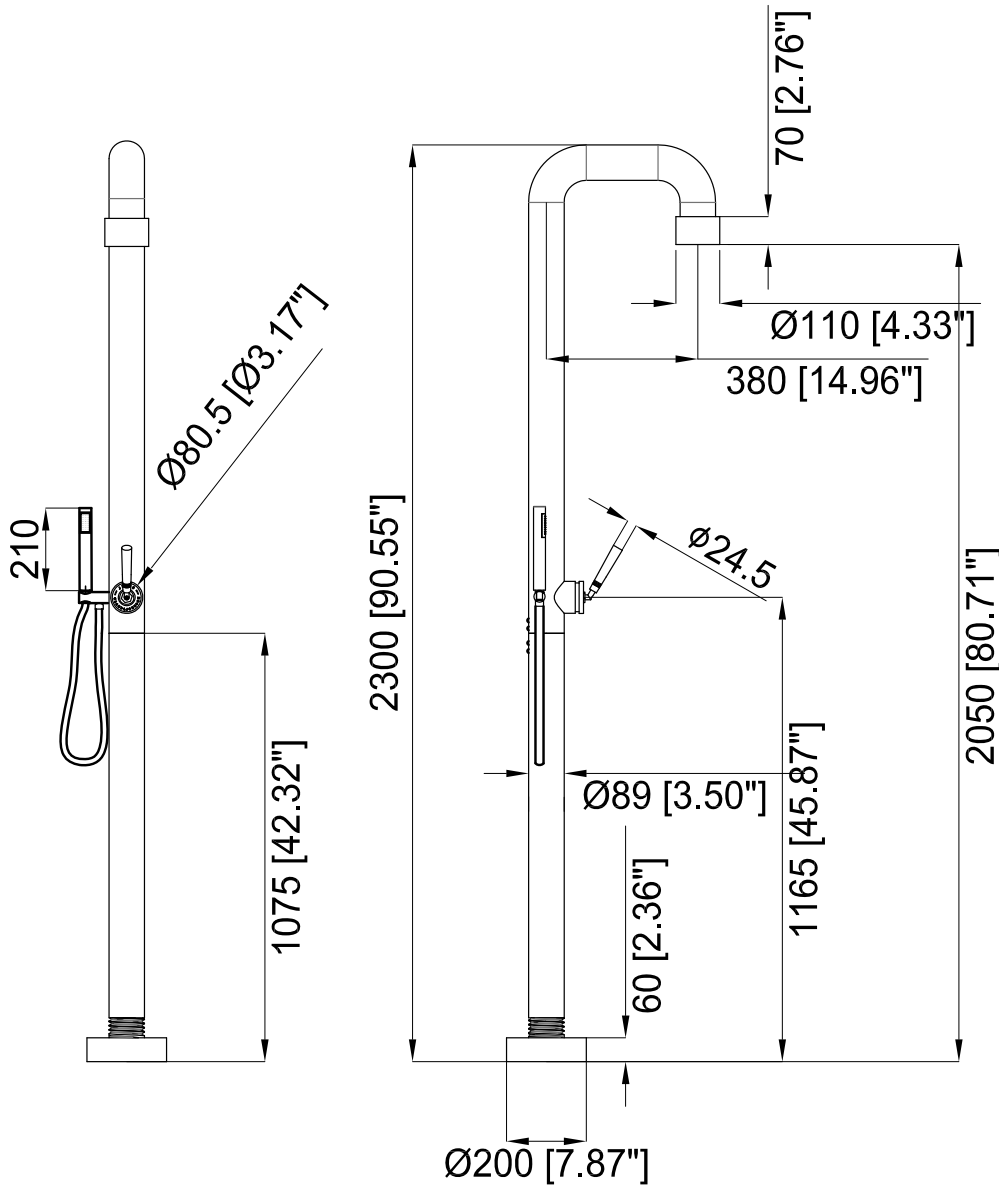

Article code:
 400-7400 (soho-02-hammer)
 Cartridge: Sedal / progressive
 Material: Stainless Steel r304
 Coating: hammercoat black (1.5)
 Electro powder spraying
 Cleaning: soapwater or alcohol
 Connection: nylon^(out)/epdm⁽ⁱⁿ⁾
 rubber coated flexhose with
 brass swivel

Lenght of flexhose 150 cm
 Flow at water of 38°C /100,4°F
 10l /2,6gal p/m at 3bar presure

Dimension package:
 L 150 x W 58 x H 20cm
 L 59.1 x W 22.8 x H 7.9"
 Total weight: 19.4 kg /41.9lbs
 Package weight: 3,4kg /6.62lbs

Placing on a water-tight floor
 2 Year warranty

HS code: 84818011900

Note: UV radiation and extreme temperature can affect the color and structure of the JEE-O soho surface.

www.jee-o.com

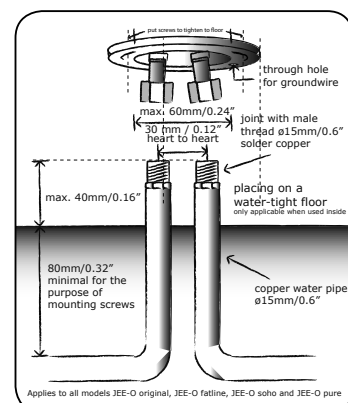

Applies to all models JEE-O original, JEE-O fatline, JEE-O soho and JEE-O pure

